

**ap**

AURORA PUMP A member of PENTAIR PUMP GROUP

**AURORA PUMP**

BULLETIN 750/760A/REV. B

750-760 SERIES

"APCO-PM"  
"AURORA-PC"  
CONSTANT  
PRESSURE  
BOOSTER SYSTEMS

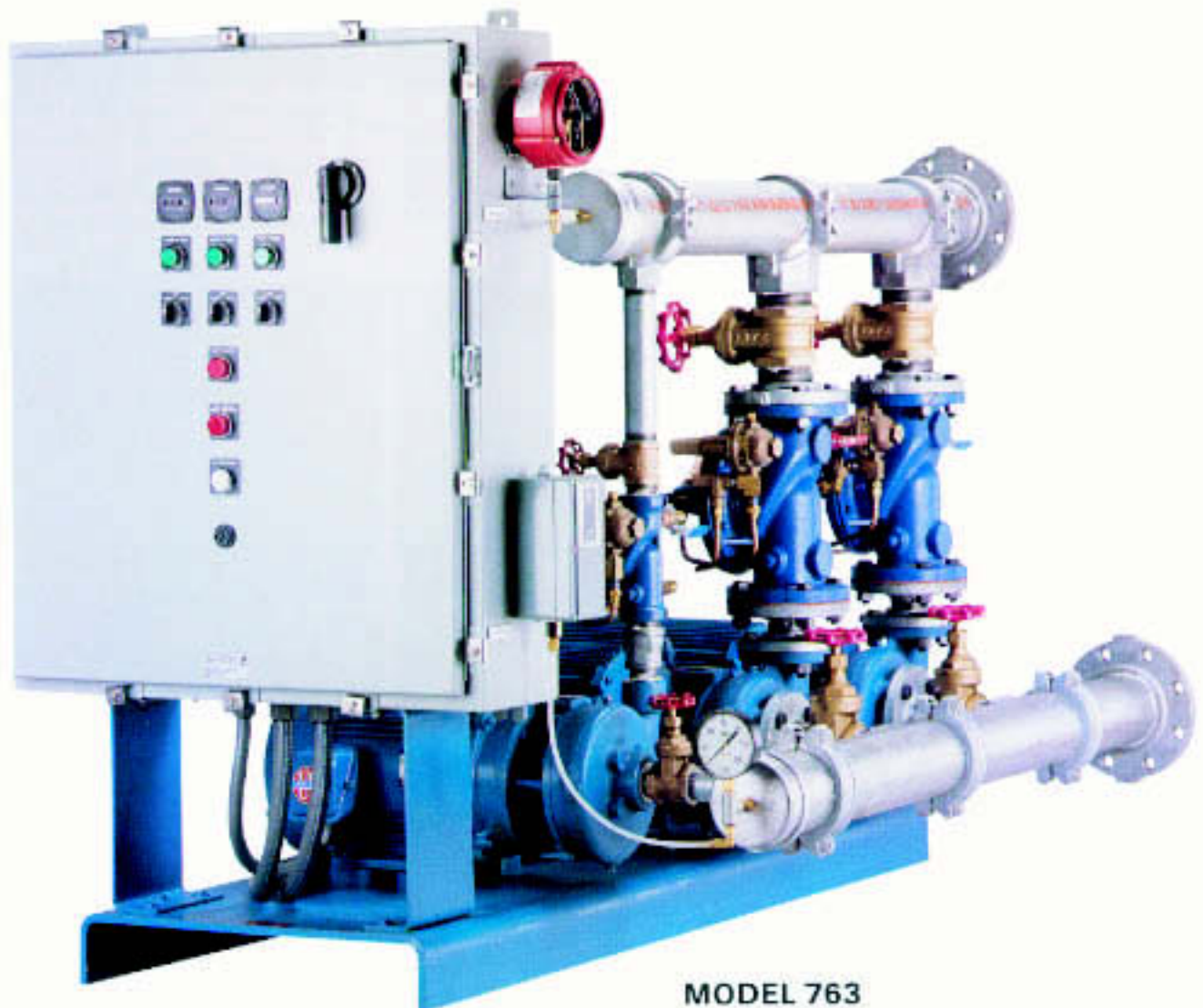

MODEL 763

**motralec**

4 rue Lavoisier . ZA Lavoisier . 95223 HERBLAY CEDEX  
Tel. : 01.39.97.65.10 / Fax. : 01.39.97.68.48  
Demande de prix / e-mail : [service-commercial@motralec.com](mailto:service-commercial@motralec.com)

[www.motralec.com](http://www.motralec.com)

# INTRODUCTION CONSTANT PRESSURE PUMPING

Ever increasing public demands and uses for water causes reductions in pressure in MUNICIPAL & INDUSTRIAL PARK supply systems. With each additional new building unit that is constructed there may be a permanent or temporary water pressure problem created. Where these situations exist, they must be corrected for health and safety reasons. Aurora Pump "The Liquid Tamer" company, offers TWO alternatives. 1-CONSTANT SPEED — Constant pressure systems are economically desirable for applications up to and including 20 horsepower. Please read this bulletin and see how Aurora can solve your immediate water pressure problem. 2-VARIABLE SPEED — Constant pressure systems for applications to 60 H.P. utilize "Apco-Matic," the all electrical concept which has been specified and installed by several thousand domestic and foreign users. Apco-Matic is the ideal

solution for controlling variations in liquid pressure and a number of important features are described in Bulletin 700. Duplex constant speed constant pressure systems are provided normally as standard for most variable flow selections. For larger capacities triplex is provided.

## CURRENT SENSING PUMPING SYSTEMS

Each pump has a check valve or combination pressure reducing and check valve in its discharge line. The lead pump has a current sensor on its power lead. The lead pump is the first to run and will develop pressure which in turn is reduced to a constant pressure, preset at the pressure reducing valve by the factory. The lag pumps are in the "Auto" mode at this time of operation. When the lead pump reaches its design flow the current sensor causes the 2nd pump to start up. A current sensor on the number

two pump will cause a third pump to start should the demand continue to increase. Reduced demand will reverse the sequence logic until ultimately only the lead pump is left in operation. The system simply starts up pumps, or else shuts them off sequentially to assure that the required system pressure is constantly maintained with best efficiency.

## PRESSURE SENSING PUMPING SYSTEMS

The Control Panel incorporates pressure-sensing logic. Each pump has a check valve or combination pressure reducing and check valve in its discharge line. The lead pump will energize when system pressure drops to lower setpoint on lead pump switch. If pressure continues to stay low, the lag pump will also start. Both pumps will run on a minimum run timer and then shut down sequentially.

## QUICK REFERENCE 750/760 SERIES FEATURE SELECTOR

### STANDARD - 750/760

- Bronze fitted pump construction
- Back pullout casings
- Bronze shaft sleeves
- Dynamically balanced vacuum cast enclosed impellers
- Casing wearing rings
- 303 Stainless mechanical seals with Buna-N, Ni-Resist and carbon parts
- Pressure regulating valves
- Pilot operated
- Flanged suction and discharge
- Galvanized piping
- Pressure gauges
- Factory assembled and prewired
- System performance tested

### STANDARD - 750 ONLY

- High Efficiency JM motors
- 30" Doorway clearance installation
- 37" Doorway clearance for units with tanks
- Vibration dampening suction bases
- Model 342 Vertical Pumps

### STANDARD - 760 ONLY

- High Efficiency JM Motors
- Model 341 Horizontal Pumps

### STANDARD - CURRENT SENSING

- UL listed panel
- High temperature cut-out

### STANDARD - PRESSURE SENSING

- Low Suction Pressure Shutdown & Alarm
- Automatic Pump Alternation
- Lead Pump Failure Circuit & Alarm
- Alarm Test Circuit
- Alarm Sequence with Alarm Horn & Silence Reset
- U.L. listed Panel

### OPTIONAL - 750/760

- Aurora Power Management
- Control panel enclosures
- Power on pilot light
- Phase reversal/failure relay
- Lightning arrestors
- Circuit breakers (in lieu of fuse clips)
- Alternating 24 hour time clock
- Flow meter
- "Lead-lag" selector switch
- Space heaters
- Non-ferrous (copper) piping
- "Kit" construction
- Special units (Apco-Matic)
- Gauge panel
- Vibration dampers
- High temperature purge
- High suction pressure shutdown
- No flow shutdown
- High system pressure alarm
- Low system pressure alarm
- Remote alarm auxiliary contacts
- Hi-suction pressure or no flow shut-down switch

### OPTIONAL - CURRENT SENSING

- Low suction pressure alarm & shut down

### OPTIONAL - PRESSURE SENSING

- Lag pump sequencing by flow switches

# SYSTEM FEATURES AND ENGINEERING DETAILS

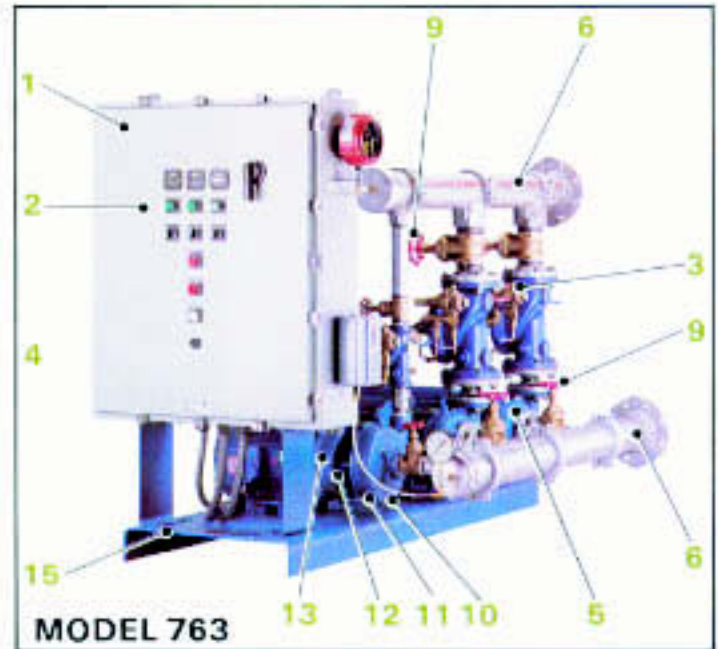

**1 COMPLETELY ASSEMBLED** and pre-wired for easy installation. Compact design allows unit to be moved thru standard 30" doorways for most systems and 37" for largest "APCO-PM" System and 48" for largest "Aurora PC" units during initial pump unit installation.

**2 PRESSURE SENSING CONTROL PANEL** has been specifically designed by Aurora Pump for pressure boosting applications and incorporates the following features as STANDARD:  
 Low Suction Pressure Shutdown  
 Automatic Pump Alternation  
 Lead Pump Failure Circuit  
 Alarm Test Circuit  
 Alarm Sequence with Alarm Horn & Silence Reset.

The Programmable Controller incorporated into the UL listed NEMA 1 Control Panel readily allows for the addition of optional control functions and alarm features.

**2 CURRENT SENSING CONTROL PANEL** in NEMA-1 enclosure is UL listed.

**PRESSURE SWITCH** (optional) low pressure shutdown and other pressure switches available.

**3 PRESSURE REDUCING** valves automatically reduce higher inlet pressure to a constant downstream pressure regardless of changing flow rate or inlet pressure. Pilot control settings are made easily. Return flow is prevented when line pressure may be reversed due to system variations. For some applications where discharge pressure is not critical or where suction pressure is relatively constant as with a reservoir, silent check

valves may be substituted for pressure reducing valves.

**4 TWO FACTORY TESTS** provided as standard assure system reliability.

**5 750 SYSTEMS** feature Aurora Pump Model 341A horizontal centrifugal end-suction pumps in bronze-fitted construction.

**5 750 SYSTEMS** feature Aurora Pump Model 342A vertical centrifugal end-suction pumps in bronze fitted construction.

**6 GALVANIZED PIPING** for corrosion resistance and to meet various local codes is schedule 40. Flanged connections Provide Easy Installation.

**7 THERMOSTAT** senses heat build up in system under certain no-flow conditions and shuts down lead pump until the temperature returns to an acceptable limit. There is no bypass and/or cooling water recirculated or wasted down the drain.

**8 PRESSURE GAUGES** located on suction and discharge manifold.

**9 GATE VALVES** provided on each pump suction and discharge branch which allow individual pumps to be serviced without interrupted operation.

**10 BRONZE SHAFT SLEEVE** prevents shaft wear and extends the entire length of the seal box. Sleeve and impeller screw are sealed by "O" ring gaskets to eliminate corrosion of the shaft by the liquid being pumped.

**11 MECHANICAL SEAL** has carbon against Ni-Resist face for optimum water performance. Long life is also

assured with 303 stainless steel metal parts — "Buna-N" elastomers.

**12 BACK PULL-OUT** design simplifies disassembly. Suction and discharge piping is not disturbed and/or misaligned when servicing pumps. Standard motor approved by a joint NEMA and the HYDRAULIC INSTITUTE provides low noise level pump operation. A carbon steel motor shaft is designed for minimum deflection not to exceed .002" at seal faces when at maximum load. Bearings are selected for a long service life under severe operating conditions.

**13 DYNAMICALLY BALANCED IMPELLER** is keyed to the shaft. Quality controlled manufacturing process assures consistently high performance. Enclosed design provides highest efficiency and is vacuum cast. A case wearing ring prevents wear on the pump casing and is easily and inexpensively replaced as necessary.

**14 "APCO-PM"** units feature flanged inlet cast vertical base which supports each pump to provide system vibration dampening qualities.

**15 GROUTABLE FORMED STEEL BASE** provides complete support, while still allowing the unit to be readily maneuvered for installation.

**HYDROPNEUMATIC PRESSURE TANK** (not illustrated) can be optionally provided to maintain system pressure during periods of low demand. Depending on specific application, the tank can be located adjacent to the system in the equipment room, remotely located, or mounted in common with the system on the baseplate.

# SYSTEM FEATURES AND MATERIAL OF CONSTRUCTION

**1 SYSTEM CAPACITY IN GPM:** The required system capacity is based on the type of units illustrated in Figure 1. Add the total values for each type of fixture selected, based on the required number of individual fixtures. Once the total flow units have been tabulated, the required system capacity can be determined from Figure 2.

**2 PUMP SELECTION:** Several factors must be taken into consideration that will have an effect on the ideal determination of the actual pump size required.

**A)** Most normal or average apartment and office building water requirements are significantly less than the maximum required. Most of the time the demand will not exceed 30% of the peak demand. As a result of this, it is both practical and economical to size the lead pump for low demand applications. The lag pumps would, in addition to the lead pump, handle extra capacity demands.

**B)** Duplex pump systems normally are sized based on a 25% lead pump, 75% lag pump capacity split.

**C)** Triplex pump systems normally are sized on a 20% lead pump with 40% for each of the lag pumps. For some applications it may be desirable to proportionately increase the percentage capacities to assure a greater standby capacity should any other pump in the system fail or should the building capacity increase.

**D)** The type of installation and horsepower requirements will effect the selection process decision; duplex or triplex. Normally the capacity range between 350 and 450 GPM is the area where the crossover will occur in making the decision, duplex vs. triplex.

**E)** When capacity requirements are about equal, a duplex system can be selected with each pump in the duplex system rated at approximately 60% of system capacity.

**3 SYSTEM HEAD IN FEET:** The required system head is based on the following facts:

**A)** Calculate the maximum elevation or the facility height in feet to which the water is to be pumped.

**B)** At the system capacity point in G.P.M. from Figure 2, add the system friction losses.

**C)** Calculate the pressure in P.S.I. that is to remain constant at the greatest distance.

**D)** Subtract the average suction head in feet that will be available to the pumps. If the minimum suction head is far below the average suction head, select a working suction head somewhere between the two.

## TOTALLY DYNAMIC HEAD COMPUTATION (In Feet or Meters)

A. Static Head (Distance From Pump to Highest Fixture): \_\_\_\_\_  
 B. Friction Loss Thru Piping: + \_\_\_\_\_  
 C. Pressure Required At Highest Fixture: \_\_\_\_\_  
 D. Suction Head At Pump: (Average Suction Pressure at Pump) \_\_\_\_\_  
 T.D.H. = \_\_\_\_\_

Note: 1 M = 3.2808 Ft.  
 1 Ft. = .3048 M.

**4 COMBINATION PRESSURE REDUCING AND CHECK VALVE SELECTION:** The recommended valve sizes are based on GPM requirements.

**5 DUPLEX & TRIPLEX PUMP SELECTION:** Once the system head and individual pump capacity has been determined, the pumps can be selected from the range charts and individual performance curves.

### MATERIAL OF CONSTRUCTION

| SYSTEM PART                        | MATERIAL  |
|------------------------------------|---|
| PUMP CASING                        | CAST IRON<br>ASTM A48   |
| PUMP WEAR RING                     | BRONZE<br>ASTM B62  |
| PUMP IMPELLER                      | BRONZE<br>ASTM B62  |
| PUMP BRACKET                       | CAST IRON<br>ASTM A48   |
| PUMP SHAFT                         | STEEL<br>AISI C1042   |
| PUMP SLEEVE                        | BRONZE<br>ASTM B62  |
| PUMP MECHANICAL SEAL               | 303 ST. STL. W. METAL PARTS, Buna-N ELAST. PARTS, N-RESIST SEAT & CARBON WASHER |
| BASE                               | STRUCT. STEEL<br>A36  |
| PIPING                             | GALV. STEEL<br>COMMERCIAL   |
| CHECK VALVE                        | CAST IRON OR BRONZE<br>ASTM B584  |
| TANK                               | BODY<br>CARBON STEEL<br>ASME 125V   |
|                                    | BAG<br>HEAVY DUTY RUBBER OR PVC FDA APP.  |
| PILOT OPERATED PRESS. REGUL. VALVE | BODY<br>CAST IRON<br>ASTM A48   |
|                                    | TRIM<br>BRASS<br>QC B-626   |
|                                    | PILOT VALVE<br>BRONZE<br>ASTM B62 W. AISI 303 S.S. TRIM                         |
| GATE VALVES                        | DIAPH.<br>NYLON REIN. Buna-N  |
|                                    | STEM<br>STAIN STL.<br>AISI 303  |
|                                    | BODY<br>BRASS<br>QQ-B-626   |
|                                    | TRIM<br>BRASS<br>QQ-B-626   |
| CONTROLLER                         | BRASS<br>QQ-B-626   |
|                                    | UL LISTED<br>COMMERCIAL   |
| GAUGE BODY                         | STEEL<br>COMMERCIAL   |

| FIXTURE VALUE UNITS        | FIGURE 1         |                 |                       |
|----------------------------|------------------|-----------------|-----------------------|
|                            | Home Private (1) | Semi-Public (2) | Commercial Public (3) |
| BATHROOM                   |                  |                 |                       |
| Flush Valves               | 8                | —               | —                     |
| Flush Tanks                | 6                | —               | —                     |
| BATHUB                     | —                | —               | —                     |
| Emergency                  | —                | —               | 4                     |
| Intercom                   | —                | —               | 20                    |
| Standard                   | 2                | 3               | 4                     |
| DOMESTIC DISHWASHER        |                  |                 |                       |
| General                    | 2                | 4               | 6                     |
| Pan & Pot                  | —                | 3               | 3                     |
| Drinking Fountain          | —                | 1               | 2                     |
| Garbage Disposal (Sink)    | 2                | 3               | —                     |
| Hose 1/2"                  | 4                | 4               | —                     |
| Ice Cube Machine           | 1                | 1               | —                     |
| Laundry Tub                | 2                | —               | —                     |
| Break Tables               | —                | 1               | 1                     |
| Washing Machine            | 4                | —               | —                     |
| LAVATORY                   |                  |                 |                       |
| Sink/Wall                  | 1                | —               | 2                     |
| Emergency                  | —                | —               | 8                     |
| Standard                   | 2                | —               | 4                     |
| SINK                       |                  |                 |                       |
| Bar                        | 3                | —               | —                     |
| General                    | —                | —               | 3                     |
| Kitchen                    | 2                | —               | 4                     |
| Laboratory                 | —                | —               | —                     |
| Service                    | 2                | 3               | 6                     |
| TOILET                     |                  |                 |                       |
| Flush Tank                 | 3                | 4               | 6                     |
| Flush Valve                | 6                | 8               | 10                    |
| URINAL                     |                  |                 |                       |
| Flush Tank                 | —                | 3               | 5                     |
| Flush Valve - Pedestal     | —                | 8               | 10                    |
| Flush Valve - Wall or Wall | 3                | 4               | 5                     |

NOTES: (1) Apartments, Homes & Private Offices  
 (2) Clubs, Commercial Offices and Motels  
 (3) Factories, Hospitals, Hotels, Public Buildings, Restaurants, Stores and Theaters

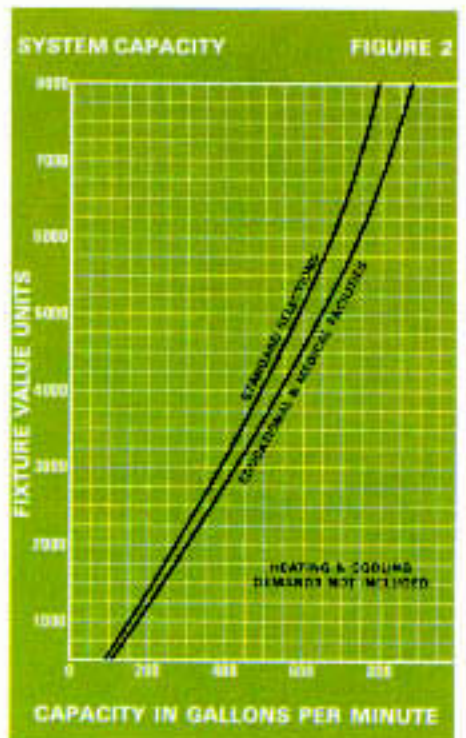

# PUMPS FOR OTHER SERVICES

## APCO-MATIC DDC

**VARIABLE SPEED SYSTEMS 700 Series, Apco-Matic** is a solid-state, variable-speed, pumping system available in simplex, duplex and triplex models. A complete and perfectly matched system of sensor, controller, motor(s) and pump(s), provides an all-electrical means of sensing and maintaining constant pressure by infinite, stepless, pump speed variation to meet the immediate demand. System response is measured in fractions of a second. Each Apco-Matic is



custom-tailored to the application, and industry acceptance has made it the overwhelming choice in variable speed systems. Capacities to 10,000 G.P.M.; Heads to 500 feet; Temperatures to 275°F.; up to 60 H.P. See Bulletin 700. Aurora Pump produces many pumps designed and sized to suit almost all pumping requirements. Additional information is available thru your local Aurora Pump Distributor or Branch Sales Office, or write to Aurora Pump for details.

### Series 900 Fire Pump Systems Diesel Engine Driven

See Bulletin 900 for additional details on electric motor and diesel driven fire pump systems.



### Schools



### Office Buildings



### Industrial Parks Municipalities



### Condominiums Sub-Divisions

### Hotels Hospitals

# ENGINEERING DETAILS AND DIMENSIONS

| 3500 R.P.M. PUMPS           |    |    |    |            |                  |        |        |       |                                      |
|-----------------------------|----|----|----|------------|------------------|--------|--------|-------|--------------------------------------|
| PUMP                        |    |    |    | MOTOR H.P. | O.D.P. WGT. LBS. | HD (1) |        | M     |                                      |
| SIZE                        | P1 | P2 | P3 |            |                  | 750    | 760    | 750   | 760                                  |
| 1-1/4 x 1-1/2 x 7<br>CODE A |    |    |    | 2          | 123              | 6-3/4  | 10-1/4 | 4-1/4 | REFER TO INDIVIDUAL DIMENSION SHEETS |
|                             |    |    |    | 3          | 144              |        |        |       |                                      |
|                             |    |    |    | 5          | 167              |        |        |       |                                      |
|                             |    |    |    | 7-1/2      | 199              |        |        |       |                                      |
| 1-1/2 x 2 x 7<br>CODE B     |    |    |    | 5          | 172              | 7-1/8  | 10-1/4 | 4-1/4 |                                      |
|                             |    |    |    | 7-1/2      | 204              |        |        |       |                                      |
|                             |    |    |    | 10         | 205              |        |        |       |                                      |
| 2 x 2-1/2 x 7A<br>CODE C    |    |    |    | 5          | 178              | 7-1/2  | 10-1/4 | 4-1/4 |                                      |
|                             |    |    |    | 7-1/2      | 210              |        |        |       |                                      |
|                             |    |    |    | 10         | 211              |        |        |       |                                      |
|                             |    |    |    | 15         | 301              |        |        |       |                                      |
|                             |    |    |    | 20         | 337              |        |        |       |                                      |
| 2-1/2 x 3 x 7B<br>CODE D    |    |    |    | 10         | 214              | 8      | 11-1/4 | 4-1/4 |                                      |
|                             |    |    |    | 15         | 306              |        |        |       |                                      |
|                             |    |    |    | 20         | 342              |        |        |       |                                      |
| 1-1/2 x 2 x 9C<br>CODE E    |    |    |    | 7-1/2      | 224              | 7-1/8  | 11-1/4 | 4-1/4 |                                      |
|                             |    |    |    | 10         | 225              |        |        |       |                                      |
|                             |    |    |    | 15         | 315              |        |        |       |                                      |
|                             |    |    |    | 20         | 351              |        |        |       |                                      |
| 2 x 2-1/2 x 9<br>CODE F     |    |    |    | 15         | 316              | 7-1/2  | 11-3/4 | 4-1/4 |                                      |
|                             |    |    |    | 20         | 352              |        |        |       |                                      |

(1) ALWAYS USE "HD" DIMENSION FOR LARGEST PUMP SIZE SPECIFIED.

| 1750 R.P.M. PUMPS        |      |    |    |            |                  | M      |        |                            |                                      |                                      |     |
|--------------------------|------|----|----|------------|------------------|--------|--------|----------------------------|--------------------------------------|--------------------------------------|-----|
| SIZE                     | PUMP |    |    | MOTOR H.P. | O.D.P. WGT. LBS. | HD (1) |        | DUPLX/TRIPLEX WITHOUT TANK |                                      | DUPLX/TRIPLEX WITH TANK              |     |
|                          | P1   | P2 | P3 |            |                  | 750    | 760    | 750                        | 760                                  | 750                                  | 760 |
| 1-1/2 x 2 x 9C<br>CODE L |      |    |    | 1          | 167              | 8-1/8  | 11-1/8 | 4-1/4                      | REFER TO INDIVIDUAL DIMENSION SHEETS | REFER TO INDIVIDUAL DIMENSION SHEETS |     |
|                          |      |    |    | 1-1/2      | 177              |        |        |                            |                                      |                                      |     |
|                          |      |    |    | 2          | 177              |        |        |                            |                                      |                                      |     |
|                          |      |    |    | 3          | 188              |        |        |                            |                                      |                                      |     |
| 2 x 2-1/2 x 9<br>CODE F  |      |    |    | 2          | 186              | 8-1/2  | 11-3/4 | 4-1/4                      |                                      |                                      |     |
|                          |      |    |    | 3          | 207              |        |        |                            |                                      |                                      |     |
|                          |      |    |    | 5          | 230              |        |        |                            |                                      |                                      |     |
| 2-1/2 x 3 x 9<br>CODE G  |      |    |    | 3          | 230              | 9      | 11-3/4 | 4-1/4                      |                                      |                                      |     |
|                          |      |    |    | 5          | 259              |        |        |                            |                                      |                                      |     |
| 1-1/2 x 2 x 12<br>CODE I |      |    |    | 7-1/2      | 291              | 8-1/8  | 13     | 6                          |                                      |                                      |     |
|                          |      |    |    | 10         | 302              |        |        |                            |                                      |                                      |     |
|                          |      |    |    | 7-1/2      | 337              |        |        |                            |                                      |                                      |     |
| 2-1/2 x 3 x 12<br>CODE M |      |    |    | 10         | 336              | 9      | 13-1/4 | 6                          |                                      |                                      |     |
|                          |      |    |    | 15         | 426              |        |        |                            |                                      |                                      |     |
|                          |      |    |    | 20         | 464              |        |        |                            |                                      |                                      |     |
|                          |      |    |    | 7-1/2      | 311              |        |        |                            |                                      |                                      |     |
| 2 x 3 x 11<br>CODE P     |      |    |    | 10         | 312              | 9      | 12-1/4 | 6                          |                                      |                                      |     |
|                          |      |    |    | 10         | 312              |        |        |                            |                                      |                                      |     |

(1) ALWAYS USE "HD" DIMENSION FOR LARGEST PUMP SIZE SPECIFIED.

| DIRECT ACTING VALVE |       |    |       |
|---------------------|-------|----|-------|
| CODE                | A     | B  | C     |
| SIZE                | 1-1/2 | 2  | 2-1/2 |
| WGT.                | 20    | 25 | 30    |

| CHECK VALVE |       |       |    |       |    |    |
|-------------|-------|-------|----|-------|----|----|
| CODE        | AC    | BC    | CD | DC    | EC | FC |
| SIZE        | 1-1/4 | 1-1/2 | 2  | 2-1/2 | 3  | 4  |
| WGT.        | 4     | 4     | 5  | 7     | 11 | 16 |

| VERTICAL PUMPS |            |                   |      |                |         |
|----------------|------------|-------------------|------|----------------|---------|
| SYSTEM MODEL   | CAP G.P.M. | FLANGED MANIFOLDS |      | WEIGHT IN LBS. |         |
|                |            | SUCT              | DSCH | MANIFOLD       | CONTROL |
| 750<br>DUPLEX  | 0-200      | 4                 | 3    | 660            | 120     |
|                | 201-400    | 4                 | 4    | 720            |         |
|                | 401-600    | 5                 | 5    | 890            |         |
|                | 601-800    | 5                 | 6    | 830            |         |

| VERTICAL PUMPS |            |                   |      |                |         |
|----------------|------------|-------------------|------|----------------|---------|
| SYSTEM MODEL   | CAP G.P.M. | FLANGED MANIFOLDS |      | WEIGHT IN LBS. |         |
|                |            | SUCT              | DSCH | MANIFOLD       | CONTROL |
| 750<br>TRIPLEX | 0-200      | 4                 | 3    | 950            | 140     |
|                | 201-400    | 4                 | 4    | 1010           |         |
|                | 401-600    | 5                 | 5    | 1320           |         |
|                | OVER 600   | 6                 | 6    | 1425           |         |

| HORIZONTAL PUMPS |            |                   |      |                |         |
|------------------|------------|-------------------|------|----------------|---------|
| SYSTEM MODEL     | CAP G.P.M. | FLANGED MANIFOLDS |      | WEIGHT IN LBS. |         |
|                  |            | SUCT              | DSCH | MANIFOLD       | CONTROL |
| 760<br>DUPLEX    | 0-450      | 4                 | 4    | 575            | 90      |
|                  | 0-450      | 4                 | 4    | 600            |         |
|                  | 451-600    | 5                 | 5    | 625            |         |
|                  | 451-600    | 5                 | 5    | 650            |         |
|                  | 601-800    | 5                 | 6    | 700            |         |
|                  | 601-800    | 5                 | 6    | 725            |         |

| HORIZONTAL PUMPS |            |                   |      |                |         |
|------------------|------------|-------------------|------|----------------|---------|
| SYSTEM MODEL     | CAP G.P.M. | FLANGED MANIFOLDS |      | WEIGHT IN LBS. |         |
|                  |            | SUCT              | DSCH | MANIFOLD       | CONTROL |
| 760<br>TRIPLEX   | 0-450      | 4                 | 4    | 800            | 90      |
|                  | 0-450      | 4                 | 4    | 825            |         |
|                  | 451-600    | 5                 | 5    | 875            |         |
|                  | 451-600    | 5                 | 5    | 900            |         |
|                  | 601-1200   | 6                 | 6    | 950            |         |
|                  | 601-1200   | 6                 | 6    | 1025           |         |

| MODEL 762 - 763 |                   |                   |                     |
|-----------------|-------------------|-------------------|---------------------|
|                 | BASE-WGT. IN LBS. |                   | GROUT HOLES IN BASE |
|                 | WITHOUT TANK      | WHEN TANK IS USED |                     |
| DUPLEX          | 296               | 582               | 1                   |
| TRIPLEX         | 352               | 673               | 2                   |

| MODEL 762 - 763 |                   |                   |                     |
|-----------------|-------------------|-------------------|---------------------|
|                 | BASE-WGT. IN LBS. |                   | GROUT HOLES IN BASE |
|                 | WITHOUT TANK      | WHEN TANK IS USED |                     |
| DUPLEX          | 196               | 357               | 1                   |
| TRIPLEX         | 272               | 433               | 1                   |

| PILOT OPERATED VALVE |       |       |    |       |    |     |
|----------------------|-------|-------|----|-------|----|-----|
| CODE                 | AP    | BP    | CP | DP    | EP | FP  |
| SIZE                 | 1-1/4 | 1-1/2 | 2  | 2-1/2 | 3  | 4   |
| WGT.                 | 40    | 40    | 50 | 70    | 90 | 125 |

## NOTES:

(1) Dimensions and weights are approximate.

(2) All dimensions are in inches and may vary ± 1/32".

(3) Add pumps, base, manifolds, pressure regulating valves, or check valves, tank, if required, and controller weight to unit weight.

(4) Not for construction purposes unless specified.

(5) Aqualis Pump reserves the right to make revisions to its products and their specifications, and to this bulletin and related information, without notice.

(6) When making pump selections, do not mix 1750 R.P.M. and 3500 R.P.M. pumps or 7" and 9" pumps.

(7) Refer to individual dimension sheets for complete dimensions on all units.

# 750 SERIES ENGINEERING DETAILS AND DIMENSIONS

## DUPLEX

| 750 SERIES - DIMENSIONS |              |        |           |
|-------------------------|--------------|--------|-----------|
| DIM                     | DUPLEX       |        |           |
|                         | WITHOUT TANK | 1750   | WITH TANK |
|                         | 3500         |        |           |
| HA                      | 29-1/2       | 29-1/2 | 36        |
| HB                      | 56           | 74     | 95        |
| HE                      | 14           | 21     | 21        |
| HF                      | 43-1/2       | 61-1/2 | 79-1/2    |
| HG                      | 3            | 3      | 4         |
| HP                      | 7-3/4        | 7-1/2  | 7-1/2     |
| VS                      | 42"          | 42"    | 48**      |

\*48" when 6" PRV is used; \*\*54" when 4" PRV is used

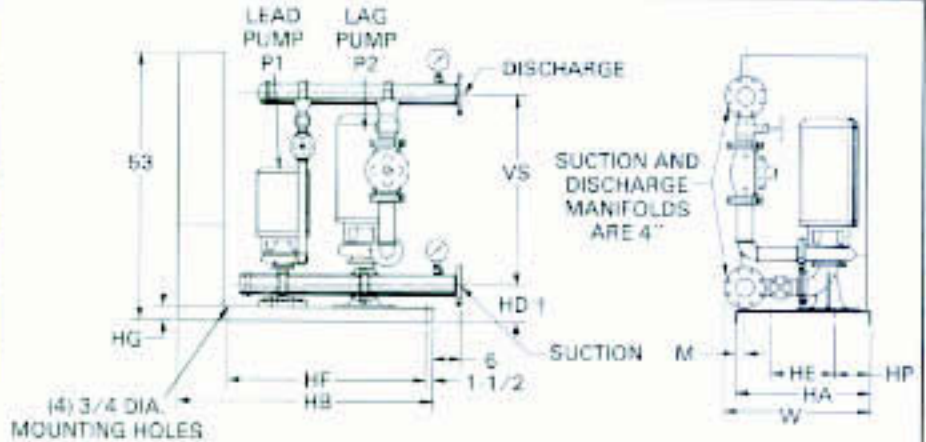

## DUPLEX WITH TANK

WITH TANK

REFER TO PAGE 9 FOR TANK DIMENSIONS

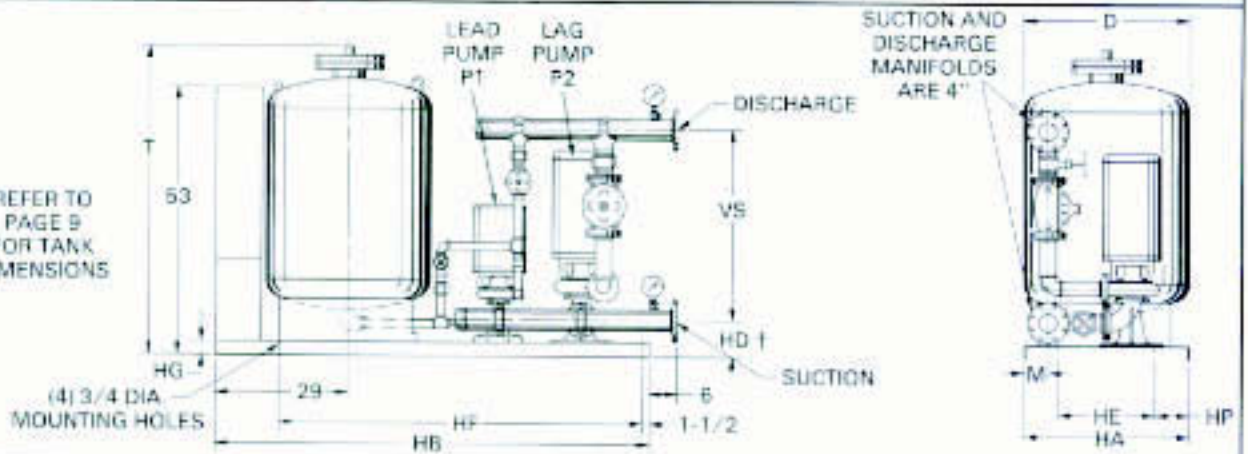

## TRIPLEX

| 750 SERIES - DIMENSIONS |              |        |           |
|-------------------------|--------------|--------|-----------|
| DIM.                    | TRIPLEX      |        |           |
|                         | WITHOUT TANK | 1750   | WITH TANK |
|                         | 3500         |        |           |
| HA                      | 29-1/2       | 29-1/2 | 36        |
| HB                      | 59           | 95     | 100       |
| HE                      | 14           | 21     | 21        |
| HF                      | 56-1/2       | 79-1/2 | 92-1/2    |
| HG                      | 3            | 3      | 4         |
| HP                      | 7-3/4        | 7-1/2  | 7-1/2     |
| VS                      | 42"          | 42"    | 48**      |

\*48" when 4" PRV is used; \*\*54" when 6" PRV is used

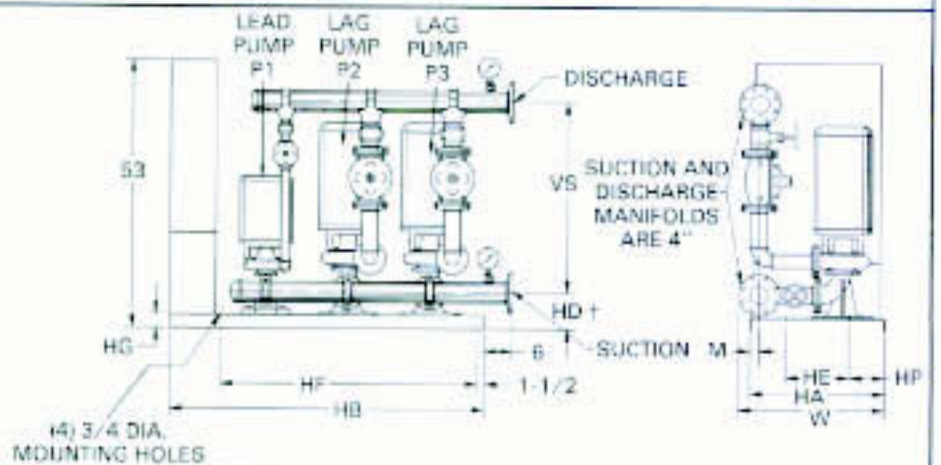

## TRIPLEX WITH TANK

WITH TANK

REFER TO PAGE 9 FOR TANK DIMENSIONS

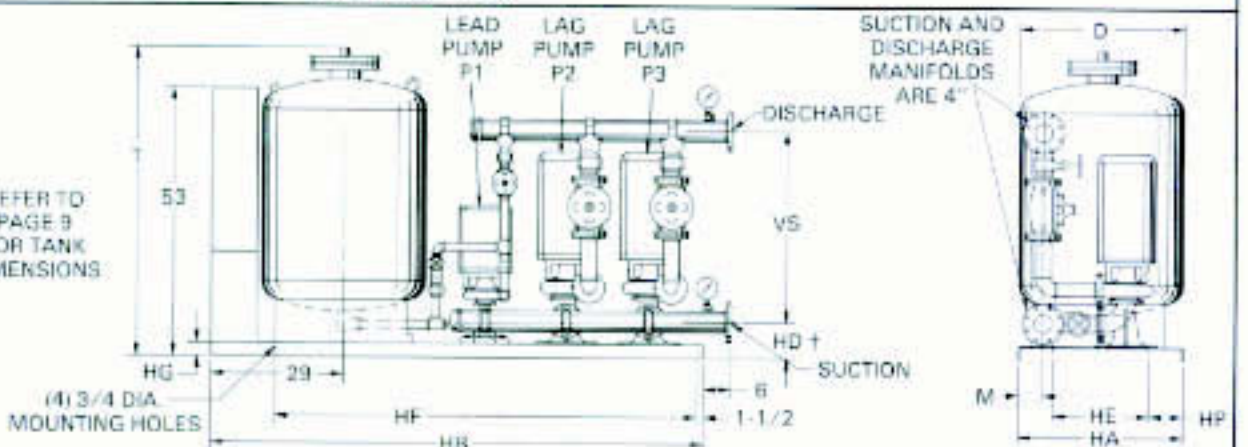

# 760 SERIES ENGINEERING DETAILS AND DIMENSIONS

## DUPLEX

| 760 SERIES - DIMENSIONS |              |           |
|-------------------------|--------------|-----------|
| DUPLEX                  |              |           |
| DIM                     | WITHOUT TANK | WITH TANK |
| HB                      | 48           | 84        |
| HF                      | 36           | 74        |
| W MAX                   | 48           | 48        |

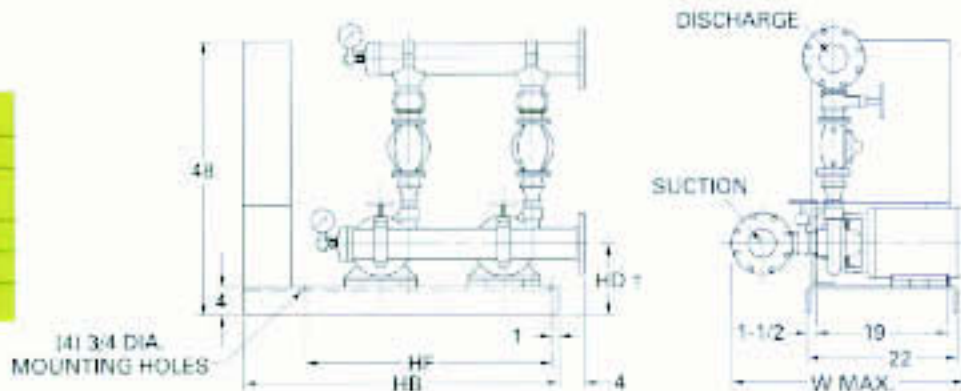

## DUPLEX

WITH TANK

REFER TO PAGE 9 FOR TANK DIMENSIONS

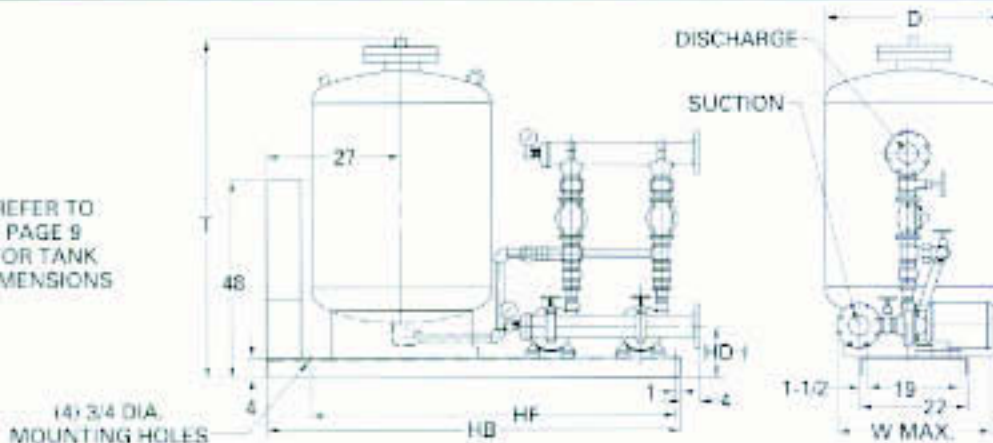

## TRIPLEX

| 760 SERIES - DIMENSIONS |              |           |
|-------------------------|--------------|-----------|
| TRIPLEX                 |              |           |
| DIM                     | WITHOUT TANK | WITH TANK |
| HB                      | 84           | 102       |
| HF                      | 54           | 92        |
| W MAX                   | 48           | 48        |

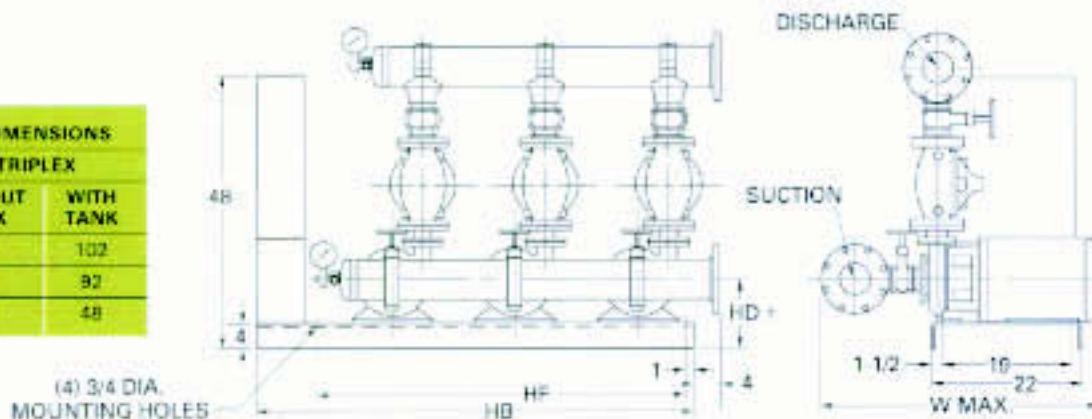

## TRIPLEX

WITH TANK

REFER TO PAGE 9 FOR TANK DIMENSIONS

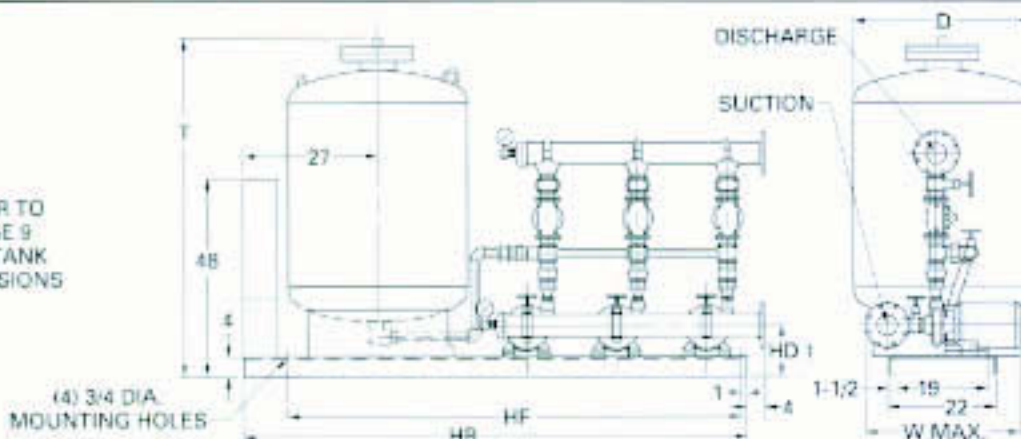

# RANGE CHARTS 3500 AND 1750 R.P.M.

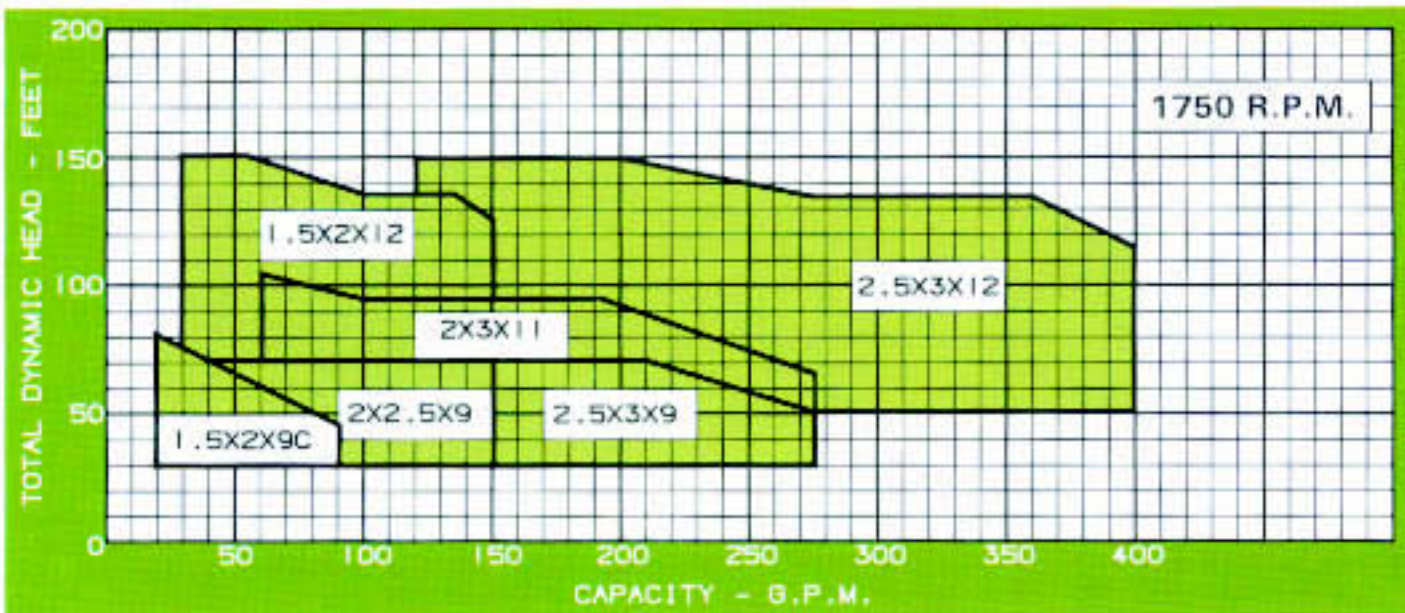
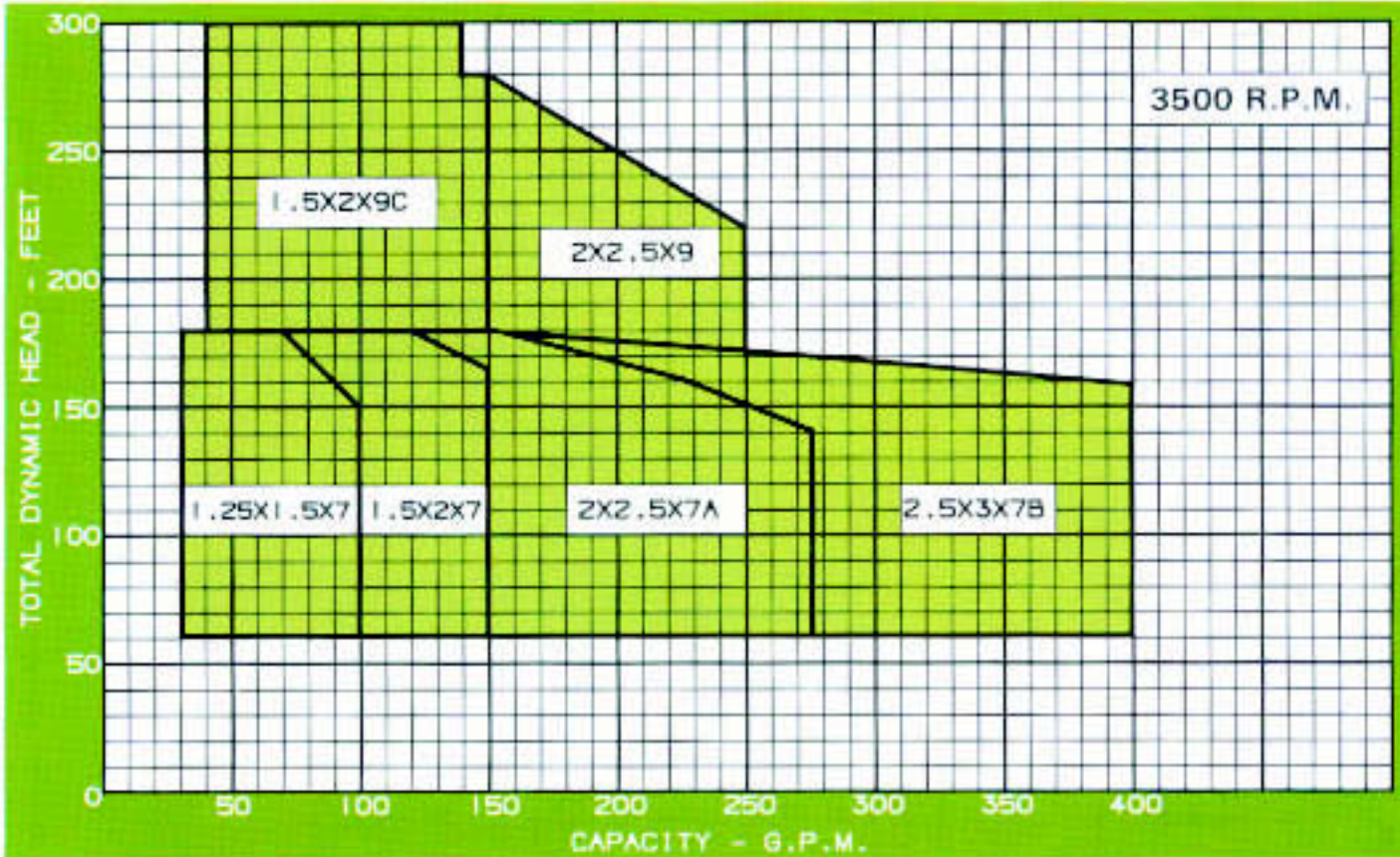

NOTES: (1) When making selections, do not combine T\* and R\* pumps. (2) When making selections, do not combine 3500 R.P.M. and 1750 R.P.M. Pumps. (3) When making selections, do not combine horizontal and vertical pumps.

## HYDROPNEUMATIC TANKS

| TANK SIZE<br>(GALLONS) | T  | D  | WEIGHT  |         |         |         |
|------------------------|----|----|---------|---------|---------|---------|
|                        |    |    | 125 PSI | 175 PSI | 200 PSI | 250 PSI |
| 70                     | 58 | 24 | 271     | 325     | —       | 400     |
| 106                    | 53 | 30 | 284     | 343     | —       | 435     |
| 132                    | 51 | 30 | 290     | 359     | —       | 465     |
| 158                    | 70 | 30 | 350     | 438     | —       | 500     |
| 170                    | 80 | 30 | —       | —       | 473     | —       |
| 211                    | 89 | 38 | 513     | 626     | —       | 813     |

The contractor shall furnish and install an Aurora Variable Flow (Duplex or Triplex) Constant Pressure Booster System as manufactured by Aurora Pump. The unit shall have a total system capacity of \_\_\_\_\_ GPM at a discharge head of \_\_\_\_\_ feet when supplied with a working suction head of \_\_\_\_\_ feet. Each pump shall be sized as indicated for a % of the total flow.

Duplex System  
 Pump P1 = \_\_\_\_\_ GPM \_\_\_\_\_ % System  
 Pump P2 = \_\_\_\_\_ GPM \_\_\_\_\_ % System  
 Triplex System  
 Pump P1 = \_\_\_\_\_ GPM \_\_\_\_\_ % System  
 Pump P2 = \_\_\_\_\_ GPM \_\_\_\_\_ % System  
 Pump P3 = \_\_\_\_\_ GPM \_\_\_\_\_ % System

**PIPING AND VALVES**

Each system shall be skid mounted, completely assembled and wired on a groutable formed steel base ready for installation. All piping shall be (Galvanized Schedule 40 pipe) (Type K Copper). Each system shall include suction and discharge gate valves for each pump, combination pressure regulating/non-slam check valves for each pump, flanged connections for easy disassembly and pipe supports for the upper manifold. Each system utilizing a current sensing control panel shall have a thermostat set to shut down the system during prolonged no-flow conditions; no water is to be wasted. Suction and discharge gauges shall be provided. Gauges shall have 3-1/2" faces with large scale numerals and individual air bleed type valves.

**PUMPS - 750 SERIES**

The pumps shall be Aurora vertical close-coupled end suction centrifugal pumps with back pullout design. The pump shall be constructed of cast iron casing, vacuum-cast bronze dynamically balanced impeller, bronze shaft sleeves, and bronze case wear rings. Shaft sealing shall be accomplished by means of a stainless steel mechanical seal. Pumps shall be mounted on vibration dampening, cast iron suction base support elbow.

**PUMPS - 760 SERIES**

The pumps shall be Aurora horizontal close-coupled end suction centrifugal pumps with back pullout design. The pump shall be constructed of cast iron casing, vacuum-cast bronze dynamically balanced impeller, bronze shaft sleeves, and bronze case wear rings. Shaft sealing shall be accomplished by means of a stainless steel mechanical seal.

**MOTORS**

The motors shall be NEMA type JM, closed coupled, \_\_\_\_\_ HP, 3 phase, 60 Hertz, \_\_\_\_\_ volt, Totally Enclosed Fan Cooled, High-Efficiency, 3 phase, \_\_\_\_\_ Hertz, \_\_\_\_\_ HP, \_\_\_\_\_ Voltage. Motors shall be selected so that they do not exceed their nameplate HP rating through their sequence of operation. The entire system shall be tested at the factory to assure proper sequencing to meet the design flows and pressure, and the system components shall be adjusted at the factory.

**CONTROL PANEL - PRESSURE SENSING**

Each system shall have mounted and wired a single Control Panel in a NEMA 1 enclosure with individual magnetic motor starters, ambient compensated overload relays on each phase, individual motor fuseblocks with 100 KAIC fuses, main circuit disconnect switch with door interlock, 110 volt control transformer with primary and secondary fuses. The panel shall be suitable for the horsepower and voltage of the motors. The Control Panel will incorporate pressure-sensing logic and have the following features:

- On and Off delays factory set to system operating characteristics to prevent short cycling of pumps.
- Individual pump run lights and selector switches
- Failure logic and indicating light to activate second pump if lead pump malfunctions.
- Automatic Lead/Lag pump alternation.
- Low suction pressure shutdown with alarm light, horn and reset button.
- Automatic restart after alarm condition has returned to normal, with alarm indicating light remaining lit until manually reset.
- Manually operated "Press-Test" circuit to verify alarm light and horn are operational.

The Control Panel shall also include the following indicated functions/features:  
 \_\_\_\_\_ High System Pressure Indication and shutdown logic.  
 \_\_\_\_\_ Low system pressure indication.  
 \_\_\_\_\_ No flow indication and shutdown logic by temperature switch.  
 \_\_\_\_\_ No flow indication and shutdown logic by flow switch.  
 \_\_\_\_\_ Power on light.  
 \_\_\_\_\_ Low Suction Pressure Remote Alarm contacts.  
 \_\_\_\_\_ Low System Pressure Remote Alarm contacts.  
 \_\_\_\_\_ High System Pressure Remote Alarm contacts.

\_\_\_\_\_ Lead Pump Fail Remote Alarm contacts.  
 \_\_\_\_\_ Elapsed time hour meter for each pump.  
 \_\_\_\_\_ Gauge panel.

**CONTROL PANEL - CURRENT SENSING**

Each system shall have a single panel completely wired in a NEMA-1 enclosure with individual magnetic motor starters and overload protection on each phase, individual fuse blocks, main circuit disconnect switch with door interlock, individual running pilot lights and selector switches, 110V control transformer with fuses, minimum run timer on the lag pump(s), overload relay for malfunction of the lead pump (P1). The panel shall have internal reset buttons and shall be mounted on support legs fixed directly to the base. The panel shall be UL Listed and also labeled accordingly.

**POWER MANAGEMENT**

The contractor shall furnish an Aurora Power Management Mode control in order to maximize efficient horsepower loading and minimize energy consumption, in cases where the pumps on the system are not equally sized, as follows: When the lead pump is operating at full load, the control will automatically bring the larger lag pump on the line; if the lag pump is not operating at full demand, the controller will take the lead pump off the line automatically. If the demand continues to increase past the capacity of the lag pump, the Power Management Mode will automatically bring the lead pump back on line. When system demand decreases to the point that the lead pump can again handle the system requirement, the control shall automatically sequence to the lead pump and shut down the lag pump. In instances where a three pump system is being used, the sequencing shall be the same except that an additional mode shall be incorporated.

**TESTING**

Pumps shall be hydrostatically tested, followed by a test of all components as a system approximating field conditions.

**SERVICES**

The pump manufacturer shall assume unit responsibility and shall provide a factory trained engineer to supervise initial start-up to insure proper operation and to instruct the operating personnel in the operation and maintenance of the system.

**NOTE:** Aurora Pump reserves the right to make revisions to its products and their specifications, and to this bulletin and related information without notice.

— Your Authorized Local Distributor —

**motralec**  
 4 rue Lavoisier . ZA Lavoisier . 95223 HERBLAY CEDEX  
 Tel. : 01.39.97.65.10 / Fax. : 01.39.97.68.48  
 Demande de prix / e-mail : service-commercial@motralec.com  
[www.motralec.com](http://www.motralec.com)

**WVEMA**



**ap AURORA**  
 Foster Pump Group

**MARKETING & SALES:**  
 800 AIRPORT ROAD • NORTH AURORA, ILLINOIS U.S.A. • 60542  
 PHONE: (630) 859-7000 U.S.A. / CANADA FAX: (630) 859-7000  
 WORLDWIDE FAX: (630) 859-1226  
 WEB: [www.aurorapump.com](http://www.aurorapump.com)  
 EMAIL: [aurora\\_info@pehelpump.com](mailto:aurora_info@pehelpump.com)  
**AURORA MFG. PLANT:**  
 800 AIRPORT ROAD • NORTH AURORA, ILLINOIS U.S.A. • 60542  
 SALES OFFICES IN ALL MAJOR CITIES AND COUNTRIES  
 Refer to "Pumps" in yellow pages of your phone directory  
 for your local Distributor