

ap

AURORA PUMP A member of PENTAIR PUMP GROUP

AURORA PUMP

BULLETIN 700/REV. E

700 SERIES

APCO-MATIC DDC

VARIABLE

SPEED

PUMPING

SYSTEMS

Applications:

- HVAC Applications
- Water Supply Pumping
- Sewage Pumping

Benefits:

- Total System Responsibility
- 3-Year Warranty
- Save Money



motralec

4 rue Lavoisier . ZA Lavoisier . 95223 HERBLAY CEDEX

Tel. : 01.39.97.65.10 / Fax. : 01.39.97.68.48

Demande de prix / e-mail : service-commercial@motralec.com

www.motralec.com

APCO-MATIC VARIABLE SPEED PUMPING SYSTEM

You save money with Aurora Pump's Apco-matic Variable Speed Pumping System.

The competitive price is matched with the lowest installation cost of any system available. The Apco-matic is easy to install and start-up. And you get complete technical support from Aurora Pump experts.

Now you can get this dependable, reliable and easy-to-use system that has been field-proven in thousands of installations for over 25 years. Backed with a 3-year warranty.

You can save money in heating and air conditioning applications, as well as a wide range of water supply and sewage pumping applications.

Applications:

- Commercial Buildings
- Hospitals
- Airports
- Universities
- Industrial Complexes
- Municipal Water Installations
- Sewage Lift Stations
- Sewage Treatment Plants
- Industrial Waste Services

Benefits:

- Total System Responsibility
- 3-Year Warranty
- Competitive Price
- Save Money
- Low Cost Installation
- Easy to Install
- Easy to Use
- Easy to Upgrade
- "Best Efficiency Control"
- Save on Retrofit
- Save Money on Space
- Increase Reliability
- Increase System Security
- Technical Support

Apco-matic Typical HVAC Variable Speed Pumping System

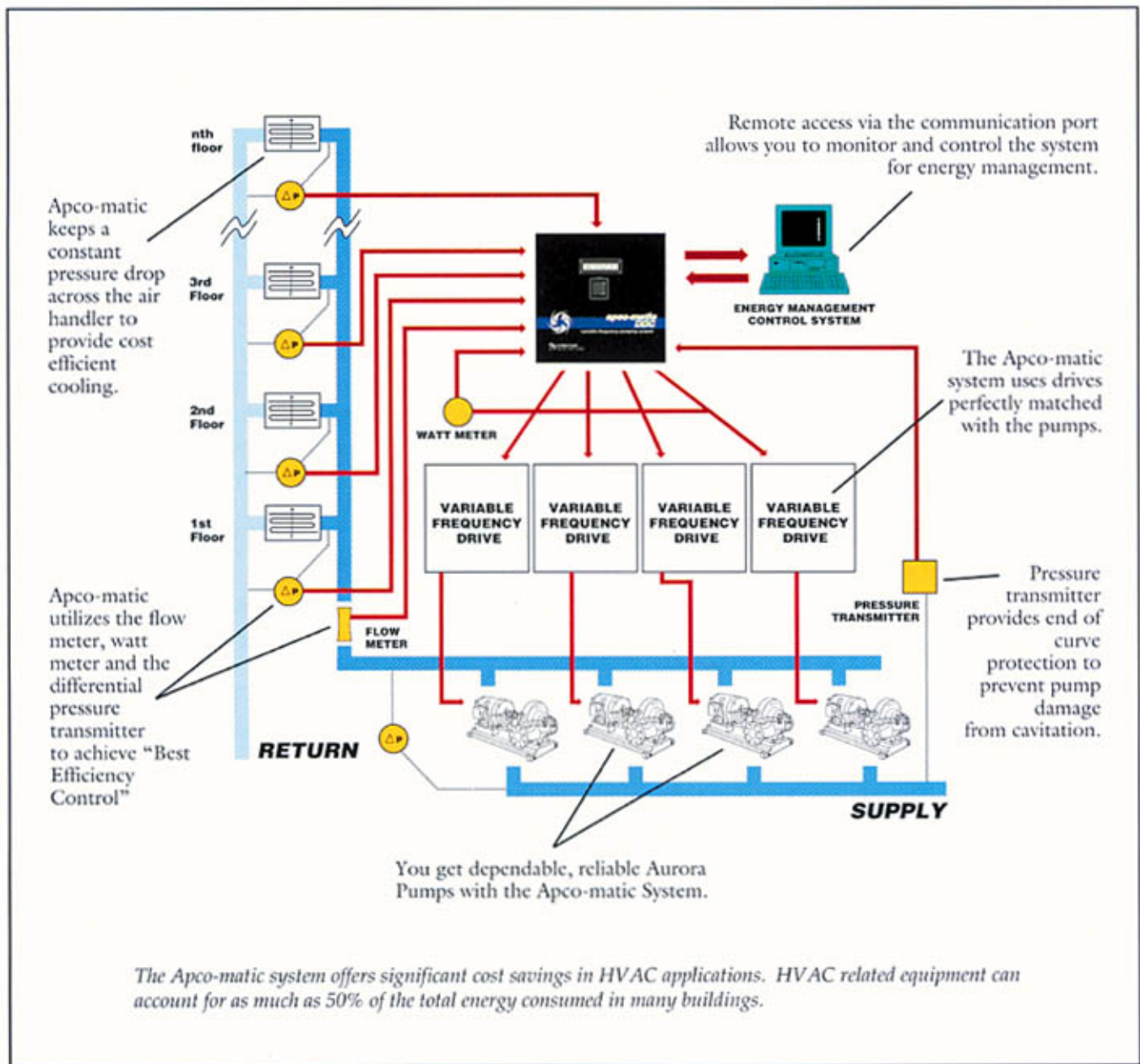

Total System Responsibility

With the Apco-matic you have one point-of-contact with total system responsibility. Aurora Pump stands behind the complete system: pumps, motors, drives, control program and sensors.

Aurora Pump guarantees that all components will interface properly and work as a system. Aurora Pump provides complete warranty, service, and on-going technical support.

Aurora Pump provides technical installation support and application and engineering assistance for the life of the system.

APCO-MATIC VARIABLE SPEED PUMPING SYSTEM

Easy, Inexpensive Installation

The Apco-matic DDC is inexpensive to install and easy to start-up. You save on installation because its light-weight and small size (< 4 cubic feet) allow handling by 1 person. Other systems require 4 people. And with the Apco-matic DDC you don't need special equipment like lifts or rigs.

The Apco-matic is easy to start up with menu-driven programmable control. The menus prompt you to enter all relevant information to set the program up. It asks for the number of pumps and transmitters, and type of add/shed control. The Apco-matic effortlessly leads you through setting up GPM, RPM, and the other parameters. It asks you for control and alarm set points.

Easy to Use and Upgrade

The Apco-matic is easy to monitor and adjust with menu-driven programmable control.

The status display allows instant overview of operating characteristics. The default status display shows you the set point, the process variable, and drive count in addition to speed, flow, or efficiency depending upon the set up.

You can choose to alternate the default display with 4 option displays to easily see the lead pump, running pumps, and pumps under maintenance. Large LED bargraphs can show set point and process variable parameters as well as speed or level for easy viewing across the room.

You can monitor system status and control the system from a remote computer terminal or energy management control system through the DDC's communication port.

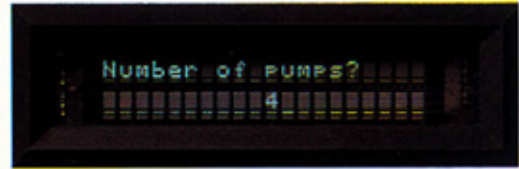

The Apco-matic is easy to start up, adjust, and upgrade with menu-driven prompts. Here, the operator has indicated there are 4 pumps in the system.

When you upgrade a system, you or your customer can easily re-enter the set up program and use the menu prompts to add pumps, drives, and transducers to the system. You need no additional software or input/output hardware.

Save Money

Pumping uses expensive electricity. The Apco-matic cuts your electricity usage by automatically pumping only what is required by the system.

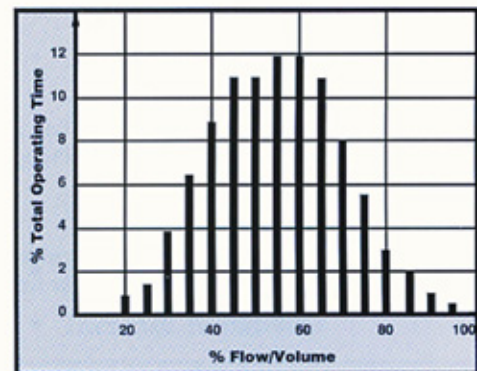

Figure 1. The typical system operates at around 50% of design flow 15 times more often than at 100%. The Apco-matic saves money by pumping only the required flow when needed.

Pumping requirements can change minute-by-minute from 100% full load to near 0% depending on the time of day, building occupancy, and the weather. Figure 1 shows that the typical duty cycle of a system operates around 50% of the full load design.

The Apco-matic monitors system demand and drives the motor and pump to provide only the required flow and pressure.

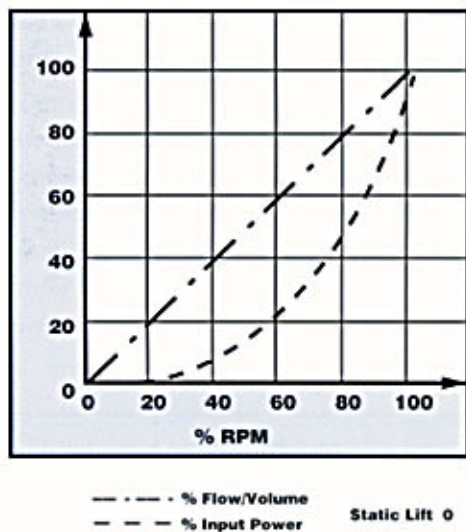

Figure 2. Apco-matic cost savings are more dramatic because electricity use falls faster than the flow with variable speed pumping.

Your cost savings are more dramatic because electrical power consumption falls faster than the flow. As shown in Figure 2, reducing the speed by 50% lowers output flow by 50%, but reduces brake horsepower and electricity use by 87.5%.

Save Money with "Best Efficiency Control"

The Apco-matic saves you even more money with multiple pump systems. In addition to achieving economies by traditional staging (adding pumps into the system as demand increases and shedding pumps as demand decreases), the Apco-matic DDC gives you "Best Efficiency Control."

The Apco-matic analyzes flow, delta pressure, RPM, and kilowatt consumption. It then automatically chooses the optimum number of pumps and sets the RPM to minimize kilowatt use.

You achieve the highest overall efficiency at lowest cost and satisfy the system requirements.

Save on Retrofit

The space-saving design makes the Apco-matic DDC ideal for retrofit installation. Space is usually very limited when replacing older units. The Apco-matic is the smallest unit available.

Significant savings can be achieved by replacing constant speed systems with the Apco-matic Variable Speed Pumping System. Figure 3 shows that the Apco-matic uses much less energy than even 2-way valve constant speed pumps.

In retrofitting existing systems, either the present or new high-efficiency motors may be used. Motors and pumps of any manufacturer, any speed, or any enclosure may be used. The upgrade is easily accomplished by adding the Apco-matic Variable Frequency Drive (VFD) and the Apco-matic DDC.

APCO-MATIC VARIABLE SPEED PUMPING SYSTEM

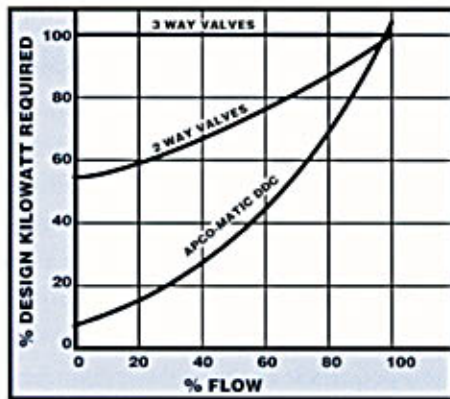

Figure 3. You save money over constant speed pumping systems in retrofit and new installations with the Apco-matic.

Save Money on Space

You save expensive square footage with the Apco-matic DDC. Its compact size is less than 4 cubic feet

Increase Reliability - Less Downtime

The Apco-matic enhanced Proportional Integral Derivative (PID) software provides extremely smooth, stable operation with changing pumping system requirements which in turn increases reliability and reduces downtime.

Apco-matic's enhanced PID software eliminates water hammer which means longer life for all system components. The enhanced PID prevents the VFD from "hunting" for the proper motor speed and increases motor and pump bearing life.

The Apco-matic employs an individual drive for each motor to increase overall system reliability. If one goes down, others stand ready to go to work. This designed redundancy keeps your system running and avoids costly system downtime.

The Apco-matic lets you increase reliability by alternating pump usage by time of day, operating hours, or by add cycle. This means the workload is evenly spread across all pumping units. It also means that no one pump will sit idle to freeze up or to let bearings develop flat spots.

Internal and external component diagnostic systems in the Apco-matic keep you or your customer constantly informed of system operational status. An exhaustive system self-test upon start-up is followed by continuous self-monitoring to assure you that your commands are being executed correctly.

External equipment diagnostics continuously check the transducers, drivers, pumps and check valves. Any problem sets off alarms and triggers corrective action. For example, if a drive fails, the DDC turns the affected device off, sets off the alarm, and directs an alternate drive, motor and pump to take over.

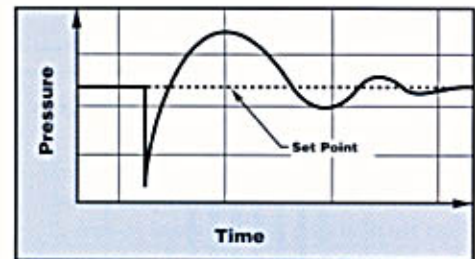

Standard PID response searches for your set point.

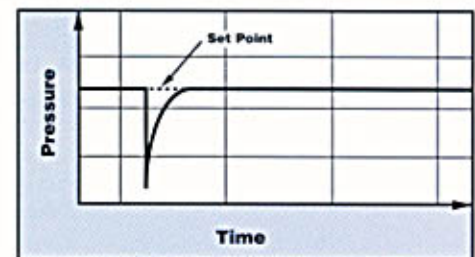

The Apco-matic enhanced PID smoothly returns to your set point and increases motor and pump bearing life.



You increase reliability by easily alternating pump use by time of day, operating hours, or by the add cycle. This menu shows that operating hours are being used to alternate pump usage.

Variable Speed vs. Constant Speed Pumping

While variable speed pumping is the best answer for many applications, Aurora Pump recognizes that there are some situations where constant speed is the optimum solution. Please call us for a free, no nonsense, cost-benefit analysis of variable vs. constant speed for your application.

Increase System Security

While it is easy to set up, adjust and upgrade the Apco-matic system, two password levels ensure system security — even with remote access. You are assured of maintaining the proper operating parameters and preventing unauthorized changes.

SAVINGS WITH THE APCO-MATIC

To estimate annual savings in your system, first determine the average KW savings per hour from the above graph. Find your required flow in Gallons Per Minute (GPM) along the horizontal axis and read your average KW/HR savings along the vertical axis. Second, use your KW/HR savings in the following formula:

$$\text{KW/HR} \times \text{HRS/year} \times \text{\$/KWH} = \text{Annual Savings}$$

EXAMPLE:

- 1) For 2000 GPM, savings are 15 KW/Hour.
- 2) 15 KW x 4000 HRS/YR x .10/KWH = \$6,000

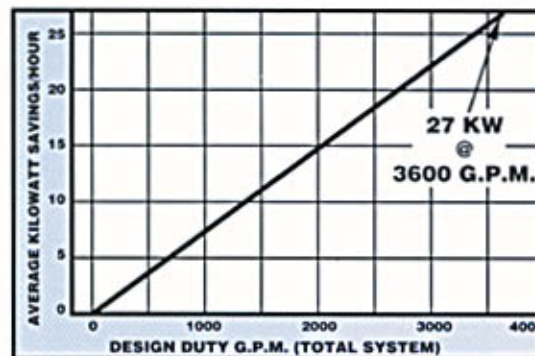

GRAPH BASED ON THE FOLLOWING PARAMETERS:

- | | |
|---------------------------------|--|
| a. 100 Foot design head | e. 5 HP thru 150 HP system |
| b. Split case Model 411 pumps | f. Savings assume high efficiency motors on both constant speed and variable frequency drives. |
| c. Average flow 1/2 design flow | g. 2-Way valves on all chilled water terminals. |
| d. Average head 59.5 feet | |

APCO-MATIC VARIABLE SPEED PUMPING SYSTEM

Technical Description

The Apco-matic DDC is a microprocessor based controller that is designed specifically for pumping applications. The bright fluorescent alpha-numeric display is readable over a wide angle under a broad range of lighting conditions, and the sealed keypad provides a convenient operator interface. Bidirectional communication with an energy management control system (EMCS) is supported via an RS-232/422/485 port. A sixteen channel analog to digital (A/D) converter accepts 4-20 mA and voltage signals from pressure, differential pressure, flow and kilowatt transmitters.

Isolated digital inputs are available for sensors and motor controller interface. Isolated analog and digital outputs are provided for constant and variable speed motor control.

Standard features include pump add/subtract control in response to RPM, flow, level, NPSHA, or system "Best Efficiency Control." The software and the input/output hardware to support all of the options are resident in

every unit. System upgrade can be readily accomplished at any time by installing the sensor or sensors required and selecting the desired operational features from the Set-up Menu.

The standard software supports up to four variable speed pumps and one jockey or auxiliary constant speed pump. The enhanced PID speed control algorithm provides 10 rate/gain breakpoints for smooth control over a wide range of dynamic conditions, and rate, gain, and breakpoints may be modified by keypad entry. System security is ensured by two levels of password as standard and an optional key lock.

The hardware consists of high quality printed circuit cards interconnected with ribbon cables, with pull-apart screw terminal strips for external connections. The standard enclosure is a compact NEMA 12 unit for wall mounting. The Apco-matic system is available mounted and wired with variable speed drives in a single enclosure, and with complete packaged and tested skid mounted pump systems.

EQUIPMENT TYPE	Microprocessor based process controller
APPLICATION	Variable speed pump control
CONTROLS	4 variable and 2 constant speed drives
INPUTS	12 pressure or differential pressure zones 4 flow inputs 1 KW input 1 system differential pressure 1 absolute suction pressure (used by end of curve protection program)
UNITS	English – GPM, FT. H ₂ O, IN. H ₂ O, PSI Metric – L/SEC, M ³ /HR, KPA, M H ₂ O
DISPLAY	Alpha-numeric, 40 character, fluorescent
PROGRAMS	Pressure, Flow, Level, Best Efficiency. Programs resident in memory and keyboard selectable.
SECURITY	Password – Level 1, Level 2, Standard Keylock – Optional
COMMUNICATION	RS232/422/485
OPERATOR INTERFACE	Keypad – 16 key sealed membrane
POWER	115 VAC 500/60 HZ +/- 15%
LIMITS	40° C at 10,000 feet, 95% Non-Condensing humidity
STANDARDS	UL FILE NO. E130054 Vol. 1 Sect. 1
ENCLOSURE	NEMA 12 standard

© 1990 Aurora Pump, North Aurora, Illinois

— Your Authorized Local Distributor —

WEMA



ap AURORA
Pentair Pump Group

MARKETING & SALES:

800 AIRPORT ROAD • NORTH AURORA, ILLINOIS U.S.A. • 60542
PHONE: (630) 859-7000 U.S.A./CANADA FAX: (630) 859-7060
WORLDWIDE FAX: (630) 859-1226

WEB: www.aurorapump.com
EMAIL: aurora_info@pentairpump.com

AURORA MFG. PLANT:
800 AIRPORT ROAD • NORTH AURORA, ILLINOIS U.S.A. • 60542

SALES OFFICES IN ALL MAJOR CITIES AND COUNTRIES
Refer to "Pumps" in yellow pages of your phone directory
for your local Distributor.

INITIAL START-UP CHECK LIST

**SUBMIT TO YOUR LOCAL AURORA PUMP SALES OFFICE
TWO WEEKS PRIOR TO REQUESTED START-UP DATE**

AURORA F.O. # _____

JOB LOCATION _____

REQUESTED START-UP DATE _____

INITIAL START-UP, OR REQUEST FOR FACTORY START-UP SHOULD NOT BE MADE UNTIL INSTALLATION OF ALL ITEMS LISTED BELOW HAS BEEN COMPLETED AND CHECKED.

CAUTION: DO NOT APPLY POWER TO THE CONTROLLER UNTIL THE UNIT HAS BEEN INSPECTED BY AN AUTHORIZED AURORA PUMP REPRESENTATIVE.

CHECK WHEN COMPLETED

- 1. PUMPS, MOTORS AND BASES HAVE BEEN PROPERLY INSTALLED AND SECURED TO THE FOUNDATION.
- 2. PUMPS AND MOTORS HAVE BEEN CHECKED AND PROPERLY ALIGNED.
- 3. ALL PIPING, VALVES, GAUGES, ETC. HAVE BEEN CORRECTLY INSTALLED AND SECURELY FASTENED.
- 4. THE CONTROL CENTER HAS BEEN INSTALLED AND ALL EXTERNAL WIRING HAS BEEN COMPLETED.
- 5. THE PRESSURE TRANSDUCER HAS BEEN PIPED INTO THE DISCHARGE SYSTEM AT LEAST 10 PIPE DIAMETERS DOWN STREAM OF CHECK VALVE, GATE VALVE OR OTHER OBSTRUCTION AND CORRECTLY WIRED TO THE CONTROL CENTER.
- 6. EACH VARIABLE SPEED MOTOR HAS BEEN WIRED TO THE CONTROL CENTER.
- 7. THE POWER SUPPLY HAS BEEN WIRED TO THE CONTROL CENTER.
- 8. ALL OPTIONAL EQUIPMENT HAS BEEN INSTALLED AND WHERE NECESSARY, WIRED TO THE CONTROL CENTER.
- 9. WATER IS AVAILABLE AT THE SUCTION OF THE PUMPS AND ALL DISCHARGE PIPING HAS BEEN COMPLETED SO THAT THE SYSTEM CAN BE PUT INTO OPERATION

INSTALLATION OF THE APCO-MATIC SYSTEM HAS BEEN COMPLETED AND THE ABOVE LISTED ITEMS CHECKED. THE SYSTEM IS READY FOR START-UP SERVICE AND ACCESS TO THE PRODUCT SITE AS WELL AS ALL LABOR NECESSARY TO INSURE SAFE AND PROPER OPERATION OF THIS UNIT BY AN AURORA PUMP REPRESENTATIVE IS HEREBY AUTHORIZED.

SIGNED _____ DATE _____

TITLE _____

NOTE:
IF ANY OF THE ABOVE STEPS HAVE BEEN OMITTED, OR ARE INCOMPLETE, THE INSTALLING CONTRACTOR OR HIS REPRESENTATIVE SHALL BE HELD LIABLE FOR ALL EXPENSES, INCLUDING LABOR, INCURRED BY THE ON-SITE AURORA REPRESENTATIVE UNTIL THE PROBLEM HAS BEEN RECTIFIED. ANY DEVIATION FROM THE ABOVE MUST BE SUBMITTED TO AURORA PUMP IN WRITING AND IS SUBJECT TO AURORA'S APPROVAL.

ap

AURORA PUMP A member of PENTAIR PUMP GROUP

AURORA PUMP

BULLETIN 750/760A/REV. B

750-760 SERIES

**"APCO-PM"
"AURORA-PC"
CONSTANT
PRESSURE
BOOSTER SYSTEMS**

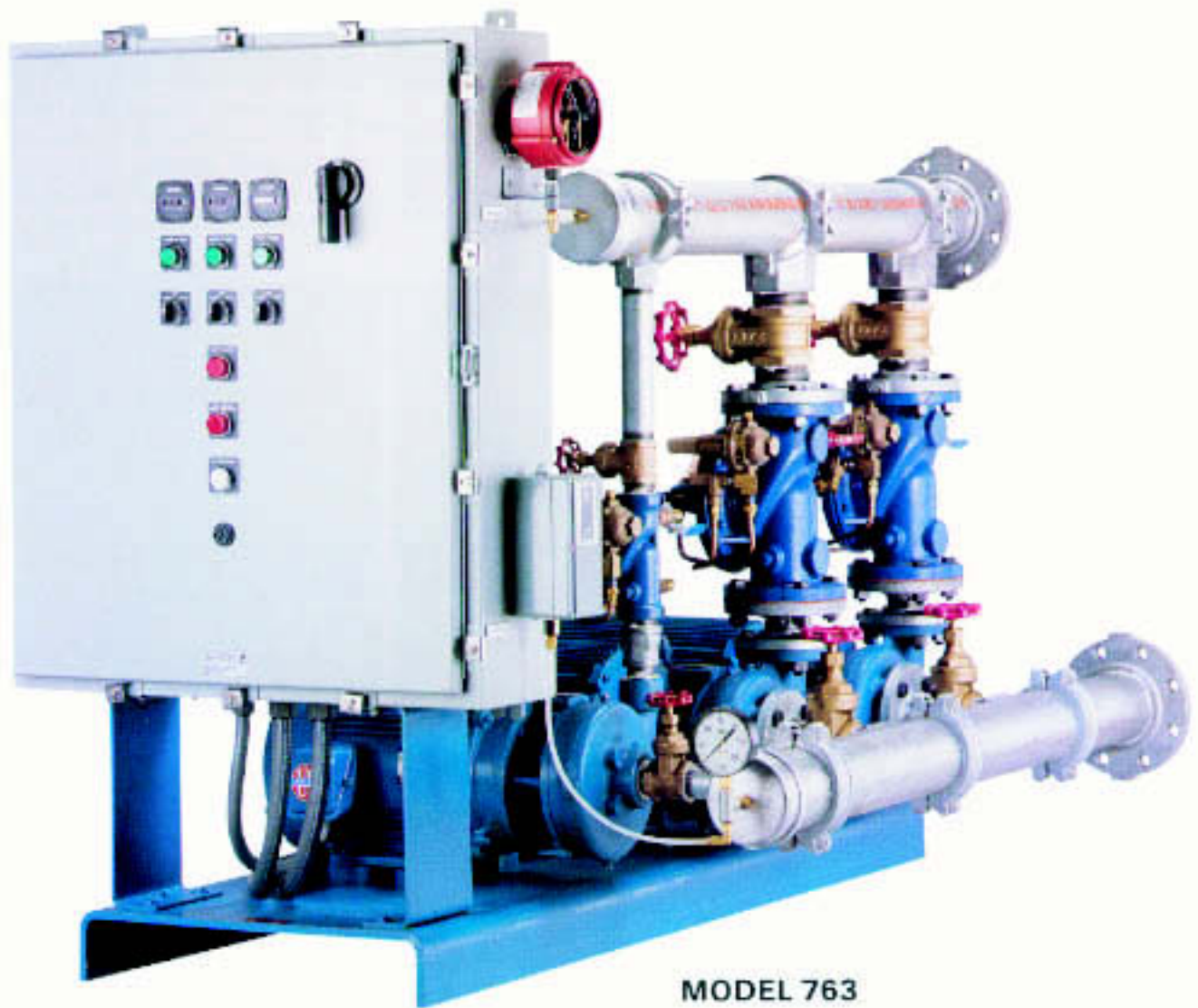

MODEL 763

INTRODUCTION CONSTANT PRESSURE PUMPING

Ever increasing public demands and uses for water causes reductions in pressure in MUNICIPAL & INDUSTRIAL PARK supply systems. With each additional new building unit that is constructed there may be a permanent or temporary water pressure problem created. Where these situations exist, they must be corrected for health and safety reasons. Aurora Pump "The Liquid Tamer" company, offers TWO alternatives. 1-CONSTANT SPEED — Constant pressure systems are economically desirable for applications up to and including 20 horsepower. Please read this bulletin and see how Aurora can solve your immediate water pressure problem. 2-VARIABLE SPEED — Constant pressure systems for applications to 60 H.P. utilize "Apco-Matic," the all electrical concept which has been specified and installed by several thousand domestic and foreign users. Apco-Matic is the ideal

solution for controlling variations in liquid pressure and a number of important features are described in Bulletin 700. Duplex constant speed constant pressure systems are provided normally as standard for most variable flow selections. For larger capacities triplex is provided.

CURRENT SENSING PUMPING SYSTEMS

Each pump has a check valve or combination pressure reducing and check valve in its discharge line. The lead pump has a current sensor on its power lead. The lead pump is the first to run and will develop pressure which in turn is reduced to a constant pressure, preset at the pressure reducing valve by the factory. The lag pumps are in the "Auto" mode at this time of operation. When the lead pump reaches its design flow the current sensor causes the 2nd pump to start up. A current sensor on the number

two pump will cause a third pump to start should the demand continue to increase. Reduced demand will reverse the sequence logic until ultimately only the lead pump is left in operation. The system simply starts up pumps, or else shuts them off sequentially to assure that the required system pressure is constantly maintained with best efficiency.

PRESSURE SENSING PUMPING SYSTEMS

The Control Panel incorporates pressure-sensing logic. Each pump has a check valve or combination pressure reducing and check valve in its discharge line. The lead pump will energize when system pressure drops to lower setpoint on lead pump switch. If pressure continues to stay low, the lag pump will also start. Both pumps will run on a minimum run timer and then shut down sequentially.

QUICK REFERENCE 750/760 SERIES FEATURE SELECTOR

STANDARD - 750/760

- Bronze fitted pump construction
- Back pullout casings
- Bronze shaft sleeves
- Dynamically balanced vacuum cast enclosed impellers
- Casing wearing rings
- 303 Stainless mechanical seals with Buna-N, Ni-Resist and carbon parts
- Pressure regulating valves
- Pilot operated
- Flanged suction and discharge
- Galvanized piping
- Pressure gauges
- Factory assembled and prewired
- System performance tested

STANDARD - 750 ONLY

- High Efficiency JM motors
- 30" Doorway clearance installation
- 37" Doorway clearance for units with tanks
- Vibration dampening suction bases
- Model 342 Vertical Pumps

STANDARD - 760 ONLY

- High Efficiency JM Motors
- Model 341 Horizontal Pumps

STANDARD - CURRENT SENSING

- UL listed panel
- High temperature cut-out

STANDARD - PRESSURE SENSING

- Low Suction Pressure Shutdown & Alarm
- Automatic Pump Alternation
- Lead Pump Failure Circuit & Alarm
- Alarm Test Circuit
- Alarm Sequence with Alarm Horn & Silence Reset
- U.L. listed Panel

OPTIONAL - 750/760

- Aurora Power Management
- Control panel enclosures
- Power on pilot light
- Phase reversal/failure relay
- Lightning arrestors
- Circuit breakers (in lieu of fuse clips)
- Alternating 24 hour time clock
- Flow meter
- "Lead-lag" selector switch
- Space heaters
- Non-ferrous (copper) piping
- "Kit" construction
- Special units (Apco-Matic)
- Gauge panel
- Vibration dampers
- High temperature purge
- High suction pressure shutdown
- No flow shutdown
- High system pressure alarm
- Low system pressure alarm
- Remote alarm auxiliary contacts
- Hi-suction pressure or no flow shut-down switch

OPTIONAL - CURRENT SENSING

- Low suction pressure alarm & shut down

OPTIONAL - PRESSURE SENSING

- Lag pump sequencing by flow switches

SYSTEM FEATURES AND ENGINEERING DETAILS

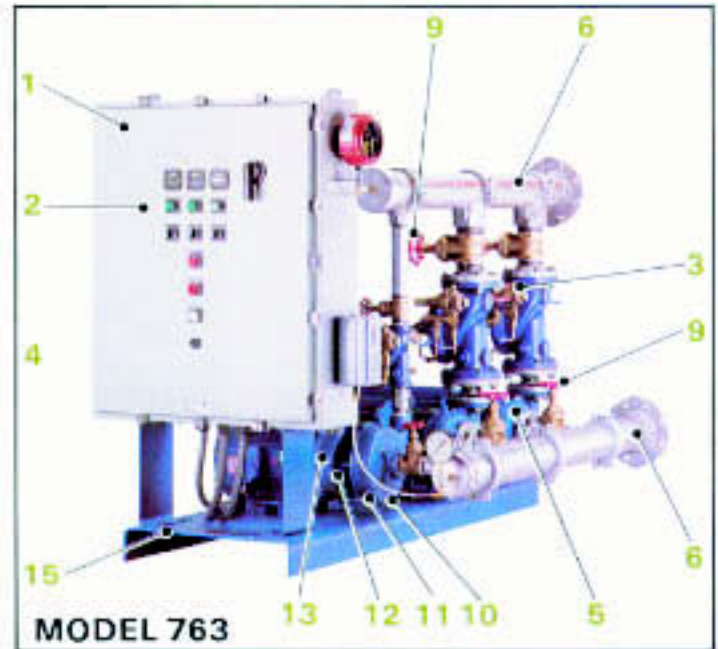

1 COMPLETELY ASSEMBLED and pre-wired for easy installation. Compact design allows unit to be moved thru standard 30" doorways for most systems and 37" for largest "APCO-PM" System and 48" for largest "Aurora PC" units during initial pump unit installation.

2 PRESSURE SENSING CONTROL PANEL has been specifically designed by Aurora Pump for pressure boosting applications and incorporates the following features as STANDARD:
 Low Suction Pressure Shutdown
 Automatic Pump Alternation
 Lead Pump Failure Circuit
 Alarm Test Circuit
 Alarm Sequence with Alarm Horn & Silence Reset.

The Programmable Controller incorporated into the UL listed NEMA 1 Control Panel readily allows for the addition of optional control functions and alarm features.

2 CURRENT SENSING CONTROL PANEL in NEMA-1 enclosure is UL listed.

PRESSURE SWITCH (optional) low pressure shutdown and other pressure switches available.

3 PRESSURE REDUCING valves automatically reduce higher inlet pressure to a constant downstream pressure regardless of changing flow rate or inlet pressure. Pilot control settings are made easily. Return flow is prevented when line pressure may be reversed due to system variations. For some applications where discharge pressure is not critical or where suction pressure is relatively constant as with a reservoir, silent check

valves may be substituted for pressure reducing valves.

4 TWO FACTORY TESTS provided as standard assure system reliability.

5 750 SYSTEMS feature Aurora Pump Model 341A horizontal centrifugal end-suction pumps in bronze-fitted construction.

5 750 SYSTEMS feature Aurora Pump Model 342A vertical centrifugal end-suction pumps in bronze fitted construction.

6 GALVANIZED PIPING for corrosion resistance and to meet various local codes is schedule 40. Flanged connections Provide Easy Installation.

7 THERMOSTAT senses heat build up in system under certain no-flow conditions and shuts down lead pump until the temperature returns to an acceptable limit. There is no bypass and/or cooling water recirculated or wasted down the drain.

8 PRESSURE GAUGES located on suction and discharge manifold.

9 GATE VALVES provided on each pump suction and discharge branch which allow individual pumps to be serviced without interrupted operation.

10 BRONZE SHAFT SLEEVE prevents shaft wear and extends the entire length of the seal box. Sleeve and impeller screw are sealed by "O" ring gaskets to eliminate corrosion of the shaft by the liquid being pumped.

11 MECHANICAL SEAL has carbon against Ni-Resist face for optimum water performance. Long life is also

assured with 303 stainless steel metal parts — "Buna-N" elastomers.

12 BACK PULL-OUT design simplifies disassembly. Suction and discharge piping is not disturbed and/or misaligned when servicing pumps. Standard motor approved by a joint NEMA and the HYDRAULIC INSTITUTE provides low noise level pump operation. A carbon steel motor shaft is designed for minimum deflection not to exceed .002" at seal faces when at maximum load. Bearings are selected for a long service life under severe operating conditions.

13 DYNAMICALLY BALANCED IMPELLER is keyed to the shaft. Quality controlled manufacturing process assures consistently high performance. Enclosed design provides highest efficiency and is vacuum cast. A case wearing ring prevents wear on the pump casing and is easily and inexpensively replaced as necessary.

14 "APCO-PM" units feature flanged inlet cast vertical base which supports each pump to provide system vibration dampening qualities.

15 GROUTABLE FORMED STEEL BASE provides complete support, while still allowing the unit to be readily maneuvered for installation.

HYDROPNEUMATIC PRESSURE TANK (not illustrated) can be optionally provided to maintain system pressure during periods of low demand. Depending on specific application, the tank can be located adjacent to the system in the equipment room, remotely located, or mounted in common with the system on the baseplate.

SYSTEM FEATURES AND MATERIAL OF CONSTRUCTION

1 SYSTEM CAPACITY IN GPM: The required system capacity is based on the type of units illustrated in Figure 1. Add the total values for each type of fixture selected, based on the required number of individual fixtures. Once the total flow units have been tabulated, the required system capacity can be determined from Figure 2.

2 PUMP SELECTION: Several factors must be taken into consideration that will have an effect on the ideal determination of the actual pump size required.

A) Most normal or average apartment and office building water requirements are significantly less than the maximum required. Most of the time the demand will not exceed 30% of the peak demand. As a result of this, it is both practical and economical to size the lead pump for low demand applications. The lag pumps would, in addition to the lead pump, handle extra capacity demands.

B) Duplex pump systems normally are sized based on a 25% lead pump, 75% lag pump capacity split.

C) Triplex pump systems normally are sized on a 20% lead pump with 40% for each of the lag pumps. For some applications it may be desirable to proportionately increase the percentage capacities to assure a greater standby capacity should any other pump in the system fail or should the building capacity increase.

D) The type of installation and horsepower requirements will effect the selection process decision; duplex or triplex. Normally the capacity range between 350 and 450 GPM is the area where the crossover will occur in making the decision, duplex vs. triplex.

E) When capacity requirements are about equal, a duplex system can be selected with each pump in the duplex system rated at approximately 60% of system capacity.

3 SYSTEM HEAD IN FEET: The required system head is based on the following facts:

A) Calculate the maximum elevation or the facility height in feet to which the water is to be pumped.

B) At the system capacity point in G.P.M. from Figure 2, add the system friction losses.

C) Calculate the pressure in P.S.I. that is to remain constant at the greatest distance.

D) Subtract the average suction head in feet that will be available to the pumps. If the minimum suction head is far below the average suction head, select a working suction head somewhere between the two.

TOTALLY DYNAMIC HEAD COMPUTATION (In Feet or Meters)

A. Static Head (Distance From Pump to Highest Fixture): _____
 B. Friction Loss Thru Piping: + _____
 C. Pressure Required At Highest Fixture: _____
 D. Suction Head At Pump: (Average Suction Pressure at Pump) _____
 T.D.H. = _____

Note: 1 M = 3.2808 Ft.
 1 Ft. = .3048 M.

4 COMBINATION PRESSURE REDUCING AND CHECK VALVE SELECTION: The recommended valve sizes are based on GPM requirements.

5 DUPLEX & TRIPLEX PUMP SELECTION: Once the system head and individual pump capacity has been determined, the pumps can be selected from the range charts and individual performance curves.

MATERIAL OF CONSTRUCTION

SYSTEM PART	MATERIAL
PUMP CASING	CAST IRON ASTM A48
PUMP WEAR RING	BRONZE ASTM B62
PUMP IMPELLER	BRONZE ASTM B62
PUMP BRACKET	CAST IRON ASTM A48
PUMP SHAFT	STEEL AISI C1045
PUMP SLEEVE	BRONZE ASTM B62
PUMP MECHANICAL SEAL	303 ST. STL. W. METAL PARTS, BUINA & ELAST. PARTS, N-RESIST SEAT & CARBON WASHER
BASE	STRUCT. STEEL A36
PIPING	GALV. STEEL COMMERCIAL
CHECK VALVE	CAST IRON OR BRONZE ASTM B584
TANK	BODY CARBON STEEL ASME 125V
	BAG HEAVY DUTY RUBBER OR PVC FDA APP.
PILOT OPERATED PRESS. REGUL. VALVE	BODY CAST IRON ASTM A48
	TRIM BRASS QC B-626
	PILOT VALVE BRONZE ASTM B62 W. AISI 303 S.S. TRIM
GATE VALVES	DIAPH. NYLON REIN. BUINA-N
	STEM STAIN STL. AISI 303
	BODY BRASS QC-B-626
GATE VALVES	TRIM BRASS QC-B-626
	STEM BRASS QC-B-626
	CONTROLLER UL LISTED COMMERCIAL
GAUGE BODY	STEEL COMMERCIAL

FIXTURE VALUE UNITS	FIGURE 1		
	Home Private (1)	Semi-Public (2)	Commercial Public (3)
BATHROOM			
Flush Valves	8	—	—
Flush Tanks	6	—	—
BATHUB	—	—	—
Emergency	—	—	4
Intercom	—	—	20
Standard	2	3	4
DOMESTIC DISHWASHER			
General	2	4	6
Pan & Pot	—	3	3
Drinking Fountain	—	1	2
Garbage Disposal (Sink)	2	3	—
Hose 1/2"	4	4	—
Ice Cube Machine	1	1	—
Laundry Tub	2	—	—
Break Tables	—	1	1
Washing Machine	4	—	—
LAVATORY			
Sink/Wall	1	1	2
Emergency	—	—	8
Standard	2	3	4
SINK			
Bar	3	4	—
General	—	—	3
Kitchen	2	—	4
Laboratory	—	—	—
Service	2	3	6
TOILET			
Flush Tank	3	4	6
Flush Valve	6	8	10
URINAL			
Flush Tank	—	3	6
Flush Valve - Pedestal	—	8	10
Flush Valve - Wall or Wall	3	4	6

NOTES: (1) Apartments, Homes & Private Offices
 (2) Clubs, Commercial Offices and Motels
 (3) Factories, Hospitals, Hotels, Public Buildings, Restaurants, Stores and Theaters

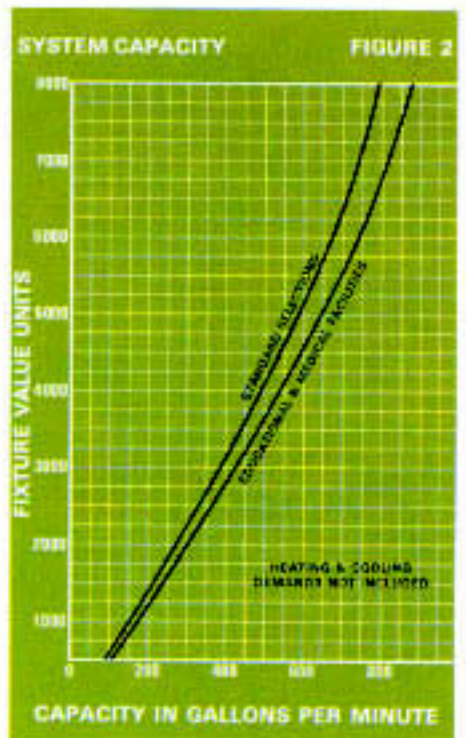

PUMPS FOR OTHER SERVICES

APCO-MATIC DDC

VARIABLE SPEED SYSTEMS 700 Series, Apco-Matic is a solid-state, variable-speed, pumping system available in simplex, duplex and triplex models. A complete and perfectly matched system of sensor, controller, motor(s) and pump(s), provides an all-electrical means of sensing and maintaining constant pressure by infinite, stepless, pump speed variation to meet the immediate demand. System response is measured in fractions of a second. Each Apco-Matic is



custom-tailored to the application, and industry acceptance has made it the overwhelming choice in variable speed systems. Capacities to 10,000 G.P.M.; Heads to 500 feet; Temperatures to 275°F.; up to 60 H.P. See Bulletin 700. Aurora Pump produces many pumps designed and sized to suit almost all pumping requirements. Additional information is available thru your local Aurora Pump Distributor or Branch Sales Office, or write to Aurora Pump for details.

Series 900 Fire Pump Systems Diesel Engine Driven

See Bulletin 900 for additional details on electric motor and diesel driven fire pump systems.



Schools



Office Buildings



Industrial Parks Municipalities



Condominiums Sub-Divisions

Hotels Hospitals

ENGINEERING DETAILS AND DIMENSIONS

3500 R.P.M. PUMPS									
PUMP				MOTOR H.P.	O.D.P. WGT. LBS.	HD (1)		M	
SIZE	P1	P2	P3			750	760	750	760
1-1/4 x 1-1/2 x 7 CODE A				2	123	6-3/4	10-1/4	4-1/4	REFER TO INDIVIDUAL DIMENSION SHEETS
				3	144				
				5	167				
				7-1/2	199				
1-1/2 x 2 x 7 CODE B				5	172	7-1/8	10-1/4	4-1/4	
				7-1/2	204				
				10	205				
2 x 2-1/2 x 7A CODE C				5	178	7-1/2	10-1/4	4-1/4	
				7-1/2	210				
				10	211				
				15	301				
				20	337				
2-1/2 x 3 x 7B CODE D				10	214	8	11-1/4	4-1/4	
				15	306				
				20	342				
1-1/2 x 2 x 9C CODE E				7-1/2	224	7-1/8	11-1/4	4-1/4	
				10	225				
				15	315				
				20	351				
2 x 2-1/2 x 9 CODE F				15	316	7-1/2	11-3/4	4-1/4	
				20	352				

(1) ALWAYS USE "HD" DIMENSION FOR LARGEST PUMP SIZE SPECIFIED.

1750 R.P.M. PUMPS						M					
SIZE	PUMP			MOTOR H.P.	O.D.P. WGT. LBS.	HD (1)		DUPLX/TRIPLEX WITHOUT TANK		DUPLX/TRIPLEX WITH TANK	
	P1	P2	P3			750	760	750	760	750	760
1-1/2 x 2 x 9C CODE L				1	167	8-1/8	11-1/8	4-1/4	REFER TO INDIVIDUAL DIMENSION SHEETS	REFER TO INDIVIDUAL DIMENSION SHEETS	
				1-1/2	177						
				2	177						
				3	188						
2 x 2-1/2 x 9 CODE F				2	186	8-1/2	11-3/4	4-1/4			
				3	207						
				5	230						
2-1/2 x 3 x 9 CODE G				3	230	9	11-3/4	4-1/4			
				5	259						
1-1/2 x 2 x 12 CODE I				7-1/2	301	8-1/8	13	6			
				10	302						
				7-1/2	337						
2-1/2 x 3 x 12 CODE M				10	336	9	13-1/4	6			
				15	426						
				20	464						
				7-1/2	311						
2 x 3 x 11 CODE P				10	312	9	12-1/4	6			
				10	312						

(1) ALWAYS USE "HD" DIMENSION FOR LARGEST PUMP SIZE SPECIFIED.

DIRECT ACTING VALVE			
CODE	A	B	C
SIZE	1-1/2	2	2-1/2
WGT.	20	25	30

CHECK VALVE						
CODE	AC	BC	CD	DC	EC	FC
SIZE	1-1/4	1-1/2	2	2-1/2	3	4
WGT.	4	4	5	7	11	16

VERTICAL PUMPS					
SYSTEM MODEL	CAP G.P.M.	FLANGED MANIFOLDS		WEIGHT IN LBS.	
		SUCT	DSCH	MANIFOLD	CONTROL
750 DUPLEX	0-200	4	3	660	120
	201-400	4	4	720	
	401-600	5	5	890	
	601-800	5	6	830	

VERTICAL PUMPS					
SYSTEM MODEL	CAP G.P.M.	FLANGED MANIFOLDS		WEIGHT IN LBS.	
		SUCT	DSCH	MANIFOLD	CONTROL
750 TRIPLEX	0-200	4	3	950	140
	201-400	4	4	1010	
	401-600	5	5	1320	
	OVER 600	6	6	1425	

HORIZONTAL PUMPS					
SYSTEM MODEL	CAP G.P.M.	FLANGED MANIFOLDS		WEIGHT IN LBS.	
		SUCT	DSCH	MANIFOLD	CONTROL
760 DUPLEX	0-450	4	4	575	97
	0-450	4	4	600	
	451-600	5	5	625	
	451-600	5	5	650	
	601-800	5	6	700	
	601-800	5	6	725	

HORIZONTAL PUMPS					
SYSTEM MODEL	CAP G.P.M.	FLANGED MANIFOLDS		WEIGHT IN LBS.	
		SUCT	DSCH	MANIFOLD	CONTROL
760 TRIPLEX	0-450	4	4	800	97
	0-450	4	4	825	
	451-600	5	5	875	
	451-600	5	5	900	
	601-1200	6	6	950	
	601-1200	6	6	1025	

MODEL 762 - 763			
	BASE-WGT. IN LBS.		GROUT HOLES IN BASE
	WITHOUT TANK	WHEN TANK IS USED	
DUPLEX	296	582	1
TRIPLEX	352	673	2

MODEL 762 - 763			
	BASE-WGT. IN LBS.		GROUT HOLES IN BASE
	WITHOUT TANK	WHEN TANK IS USED	
DUPLEX	196	357	1
TRIPLEX	272	433	1

PILOT OPERATED VALVE						
CODE	AP	BP	CP	DP	EP	FP
SIZE	1-1/4	1-1/2	2	2-1/2	3	4
WGT.	40	40	50	70	90	125

NOTES:

- (1) Dimensions and weights are approximate.
 (2) All dimensions are in inches and may vary ± 1/32".
 (3) Add pumps, base, manifolds, pressure regulating valves, or check valves, tank, if required, and controller weight to unit weight.

- (4) Not for construction purposes unless specified.
 (5) Aqualis Pump reserves the right to make revisions to its products and their specifications, and to this bulletin and related information, without notice.

- (6) When making pump selections, do not mix 1750 R.P.M. and 3500 R.P.M. pumps or 7" and 9" pumps.
 (7) Refer to individual dimension sheets for complete dimensions on all units.

750 SERIES ENGINEERING DETAILS AND DIMENSIONS

DUPLEX

750 SERIES - DIMENSIONS			
DIM	DUPLEX		
	WITHOUT TANK	1750	WITH TANK
	3500		
HA	29-1/2	29-1/2	36
HB	56	74	95
HE	14	21	21
HF	43-1/2	61-1/2	79-1/2
HG	3	3	4
HP	7-3/4	7-1/2	7-1/2
VS	42"	42"	48"

*48" when 4" PRV is used; **54" when 4" PRV is used

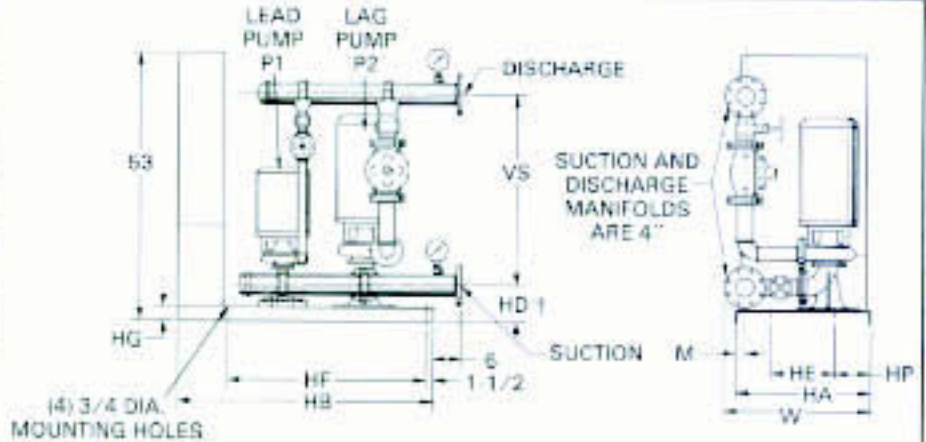

DUPLEX WITH TANK

WITH TANK

REFER TO PAGE 9 FOR TANK DIMENSIONS

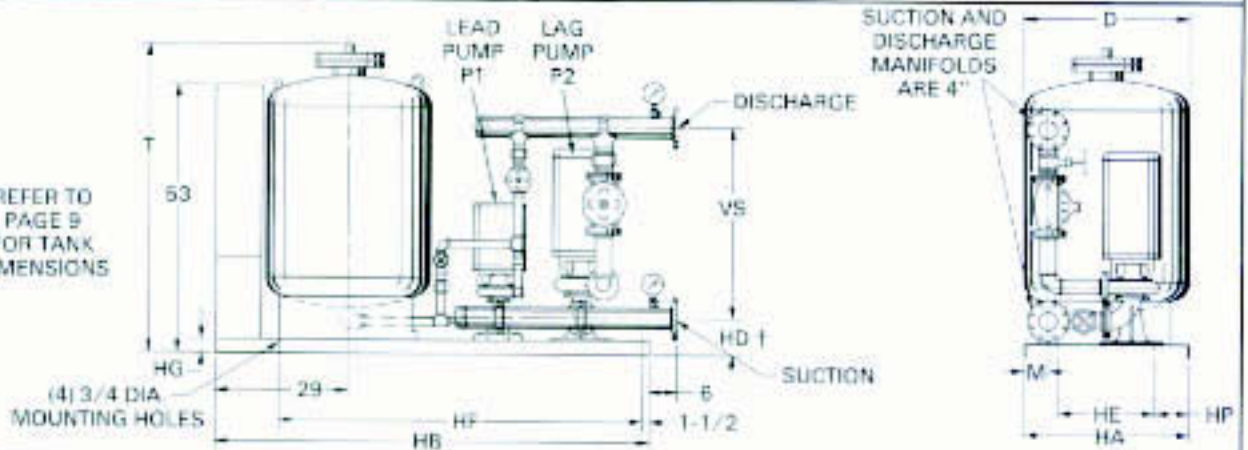

TRIPLEX

750 SERIES - DIMENSIONS			
DIM.	TRIPLEX		
	WITHOUT TANK	1750	WITH TANK
	3500		
HA	29-1/2	29-1/2	36
HB	58	95	108
HE	14	21	21
HF	56-1/2	79-1/2	92-1/2
HG	3	3	4
HP	7-3/4	7-1/2	7-1/2
VS	42"	42"	48"

*48" when 4" PRV is used; **54" when 4" PRV is used

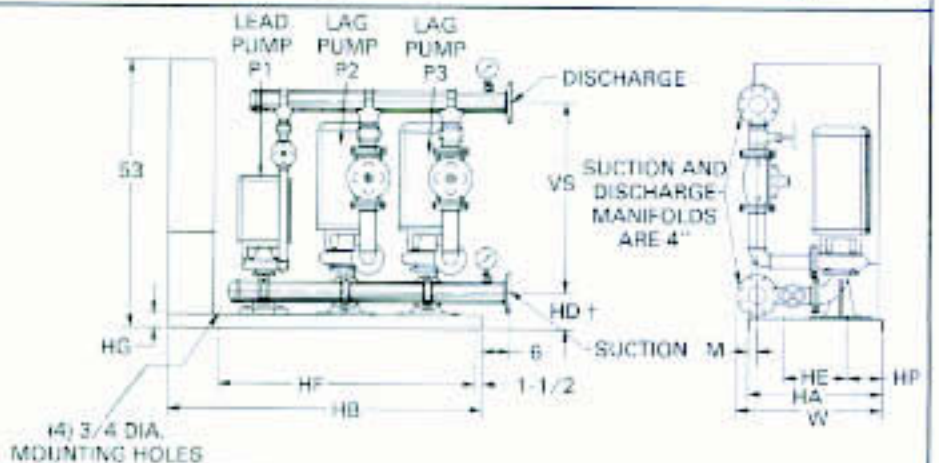

TRIPLEX WITH TANK

WITH TANK

REFER TO PAGE 9 FOR TANK DIMENSIONS

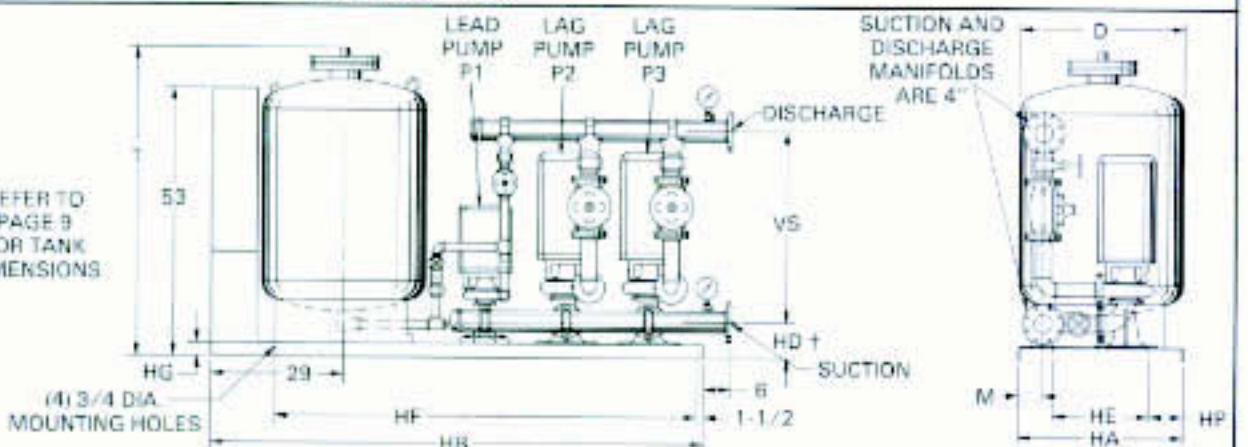

760 SERIES ENGINEERING DETAILS AND DIMENSIONS

**D
U
P
L
E
X**

760 SERIES - DIMENSIONS		
DUPLEX		
DIM	WITHOUT TANK	WITH TANK
HB	48	84
HF	36	74
W MAX	48	48

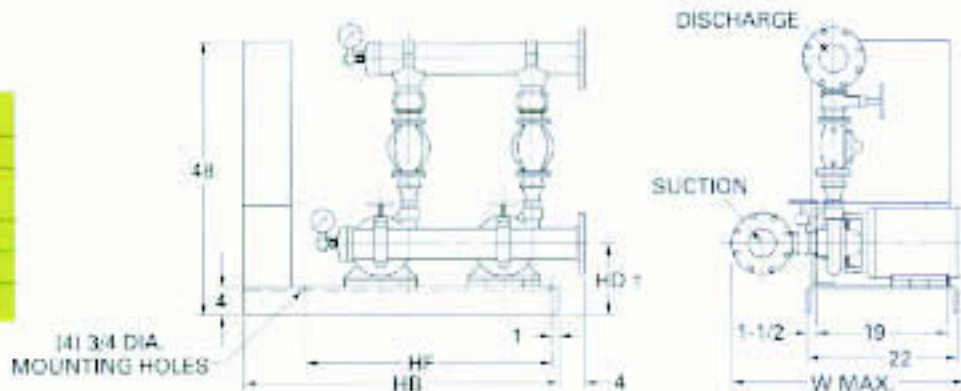

**D
U
P
L
E
X**

**W
I
T
H
T
A
N
K**

REFER TO
PAGE 9
FOR TANK
DIMENSIONS

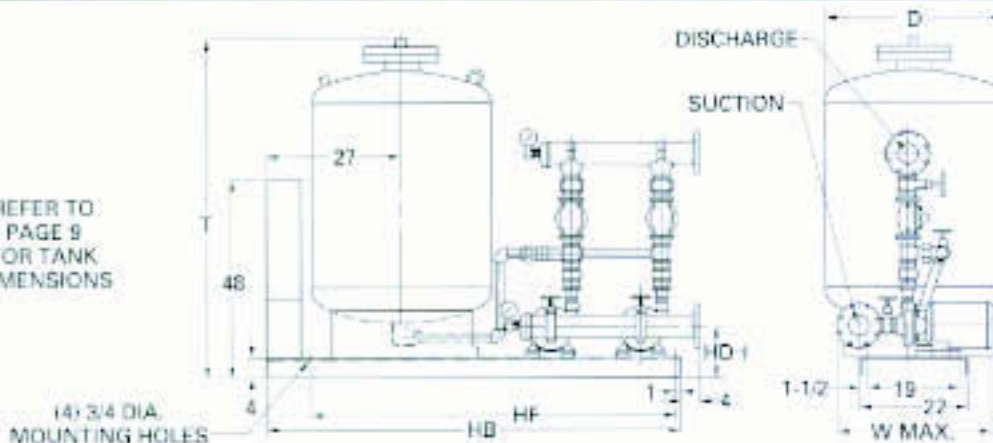

**T
R
I
P
L
E
X**

760 SERIES - DIMENSIONS		
TRIPLEX		
DIM	WITHOUT TANK	WITH TANK
HB	84	102
HF	54	92
W MAX	48	48

(4) 3/4 DIA.
MOUNTING HOLES

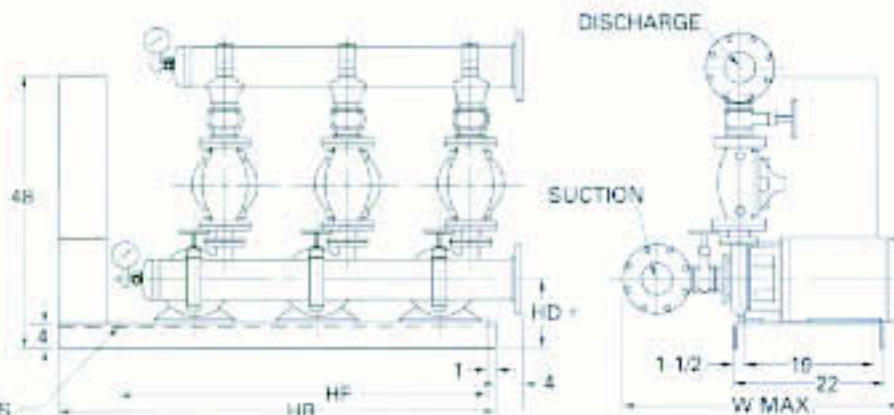

**T
R
I
P
L
E
X**

**W
I
T
H
T
A
N
K**

REFER TO
PAGE 9
FOR TANK
DIMENSIONS

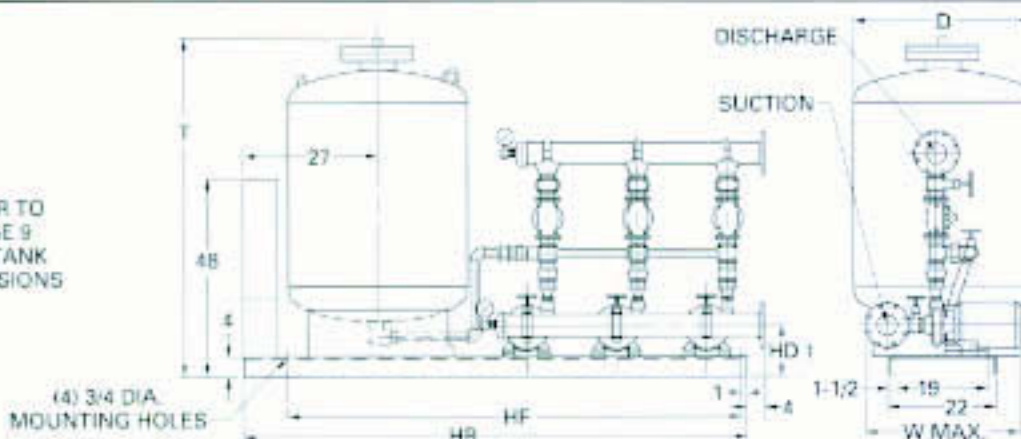

RANGE CHARTS 3500 AND 1750 R.P.M.

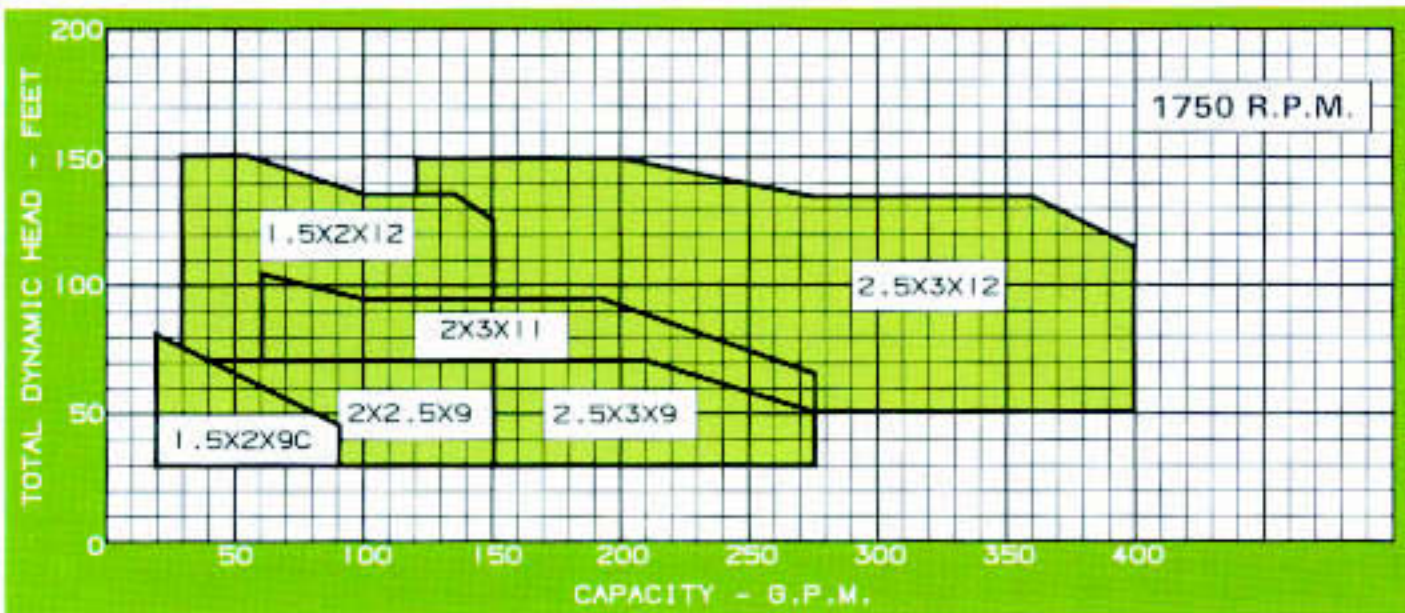
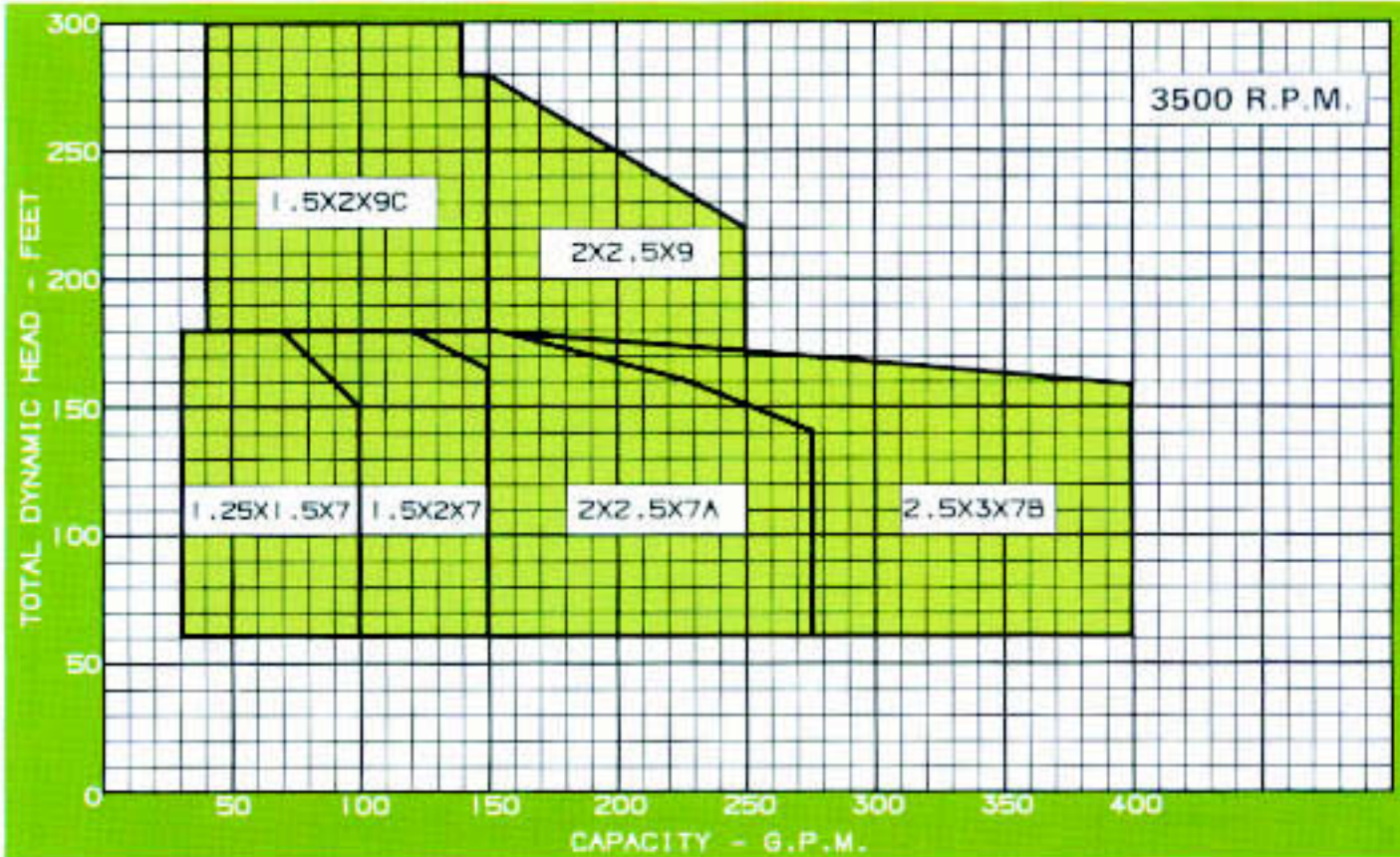

NOTES: (1) When making selections, do not combine T* and R* pumps. (2) When making selections, do not combine 3500 R.P.M. and 1750 R.P.M. Pumps. (3) When making selections, do not combine horizontal and vertical pumps.

HYDROPNEUMATIC TANKS

TANK SIZE (GALLONS)	T	D	WEIGHT			
			125 PSI	175 PSI	200 PSI	250 PSI
70	58	24	271	325	—	400
106	53	30	284	343	—	435
132	51	30	290	349	—	465
158	70	30	350	438	—	500
170	80	30	—	—	473	—
211	89	38	513	626	—	813

ENGINEERING SPECIFICATIONS

The contractor shall furnish and install an Aurora Variable Flow (Duplex or Triplex) Constant Pressure Booster System as manufactured by Aurora Pump. The unit shall have a total system capacity of _____ GPM at a discharge head of _____ feet when supplied with a working suction head of _____ feet. Each pump shall be sized as indicated for a % of the total flow.

Duplex System
Pump P1 = _____ GPM _____ % System
Pump P2 = _____ GPM _____ % System
Triplex System
Pump P1 = _____ GPM _____ % System
Pump P2 = _____ GPM _____ % System
Pump P3 = _____ GPM _____ % System

PIPING AND VALVES

Each system shall be skid mounted, completely assembled and wired on a groutable formed steel base ready for installation. All piping shall be (Galvanized Schedule 40 pipe) (Type K Copper). Each system shall include suction and discharge gate valves for each pump, combination pressure regulating/non-slam check valves for each pump, flanged connections for easy disassembly and pipe supports for the upper manifold. Each system utilizing a current sensing control panel shall have a thermostat set to shut down the system during prolonged no-flow conditions; no water is to be wasted. Suction and discharge gauges shall be provided. Gauges shall have 3-1/2" faces with large scale numerals and individual air bleed type valves.

PUMPS - 750 SERIES

The pumps shall be Aurora vertical close-coupled end suction centrifugal pumps with back pullout design. The pump shall be constructed of cast iron casing, vacuum-cast bronze dynamically balanced impeller, bronze shaft sleeves, and bronze case wear rings. Shaft sealing shall be accomplished by means of a stainless steel mechanical seal. Pumps shall be mounted on vibration dampening, cast iron suction base support elbow.

PUMPS - 760 SERIES

The pumps shall be Aurora horizontal close-coupled end suction centrifugal pumps with back pullout design. The pump shall be constructed of cast iron casing, vacuum-cast bronze dynamically balanced impeller, bronze shaft sleeves, and bronze case wear rings. Shaft sealing shall be accomplished by means of a stainless steel mechanical seal.

MOTORS

The motors shall be NEMA type JM, closed coupled, _____ HP, 3 phase, 60 Hertz, _____ volt, Totally Enclosed Fan Cooled, High-Efficiency, 3 phase, _____ Hertz, _____ HP, _____ Voltage. Motors shall be selected so that they do not exceed their nameplate HP rating through their sequence of operation. The entire system shall be tested at the factory to assure proper sequencing to meet the design flows and pressure, and the system components shall be adjusted at the factory.

CONTROL PANEL - PRESSURE SENSING

Each system shall have mounted and wired a single Control Panel in a NEMA 1 enclosure with individual magnetic motor starters, ambient compensated overload relays on each phase, individual motor fuseblocks with 100 KAIC fuses, main circuit disconnect switch with door interlock, 110 volt control transformer with primary and secondary fuses. The panel shall be suitable for the horsepower and voltage of the motors. The Control Panel will incorporate pressure-sensing logic and have the following features:

- On and Off delays factory set to system operating characteristics to prevent short cycling of pumps.
 - Individual pump run lights and selector switches
 - Failure logic and indicating light to activate second pump if lead pump malfunctions.
 - Automatic Lead/Lag pump alternation.
 - Low suction pressure shutdown with alarm light, horn and reset button.
 - Automatic restart after alarm condition has returned to normal, with alarm indicating light remaining lit until manually reset.
 - Manually operated "Press-Test" circuit to verify alarm light and horn are operational.
- The Control Panel shall also include the following indicated functions/features:

_____ High System Pressure Indication and shutdown logic.
_____ Low system pressure indication,
_____ No flow indication and shutdown logic by temperature switch.
_____ No flow indication and shutdown logic by flow switch.
_____ Power on light.
_____ Low Suction Pressure Remote Alarm contacts.
_____ Low System Pressure Remote Alarm contacts.
_____ High System Pressure Remote Alarm contacts.

_____ Lead Pump Fail Remote Alarm contacts.
_____ Elapsed time hour meter for each pump.
_____ Gauge panel.

CONTROL PANEL - CURRENT SENSING

Each system shall have a single panel completely wired in a NEMA-1 enclosure with individual magnetic motor starters and overload protection on each phase, individual fuse blocks, main circuit disconnect switch with door interlock, individual running pilot lights and selector switches, 110V control transformer with fuses, minimum run timer on the lag pump(s), overload relay for malfunction of the lead pump (P1). The panel shall have internal reset buttons and shall be mounted on support legs fixed directly to the base. The panel shall be UL Listed and also labeled accordingly.

POWER MANAGEMENT

The contractor shall furnish an Aurora Power Management Mode control in order to maximize efficient horsepower loading and minimize energy consumption, in cases where the pumps on the system are not equally sized, as follows: When the lead pump is operating at full load, the control will automatically bring the larger lag pump on the line; if the lag pump is not operating at full demand, the controller will take the lead pump off the line automatically. If the demand continues to increase past the capacity of the lag pump, the Power Management Mode will automatically bring the lead pump back on line. When system demand decreases to the point that the lead pump can again handle the system requirement, the control shall automatically sequence to the lead pump and shut down the lag pump. In instances where a three pump system is being used, the sequencing shall be the same except that an additional mode shall be incorporated.

TESTING

Pumps shall be hydrostatically tested, followed by a test of all components as a system approximating field conditions.

SERVICES

The pump manufacturer shall assume unit responsibility and shall provide a factory trained engineer to supervise initial start-up to insure proper operation and to instruct the operating personnel in the operation and maintenance of the system.

NOTE: Aurora Pump reserves the right to make revisions to its products and their specifications, and to this bulletin and related information without notice.

— Your Authorized Local Distributor —

Wwema



ap AURORA
Pump Group

MARKETING & SALES:

800 AIRPORT ROAD • NORTH AURORA, IL 60164 U.S.A. • 630-672-7000
PHONE (530) 850-7300 U.S.A./CANADA FAX (530) 850-7050
WORLDWIDE FAX (530) 850-1226

WEB: www.aurorapump.com

EMAIL: aurora_info@aurorapump.com

AURORA MFG. PLANT:

800 AIRPORT ROAD • NORTH AURORA, ILLINOIS U.S.A. • 60142

SALES OFFICES IN ALL MAJOR CITIES AND COUNTRIES

Refer to "Pumps" in yellow pages of your phone directory

for your local Distributor

**SUGGESTED PIPING ARRANGEMENT FOR
REMOTE HYDROPNEUMATIC TANK**

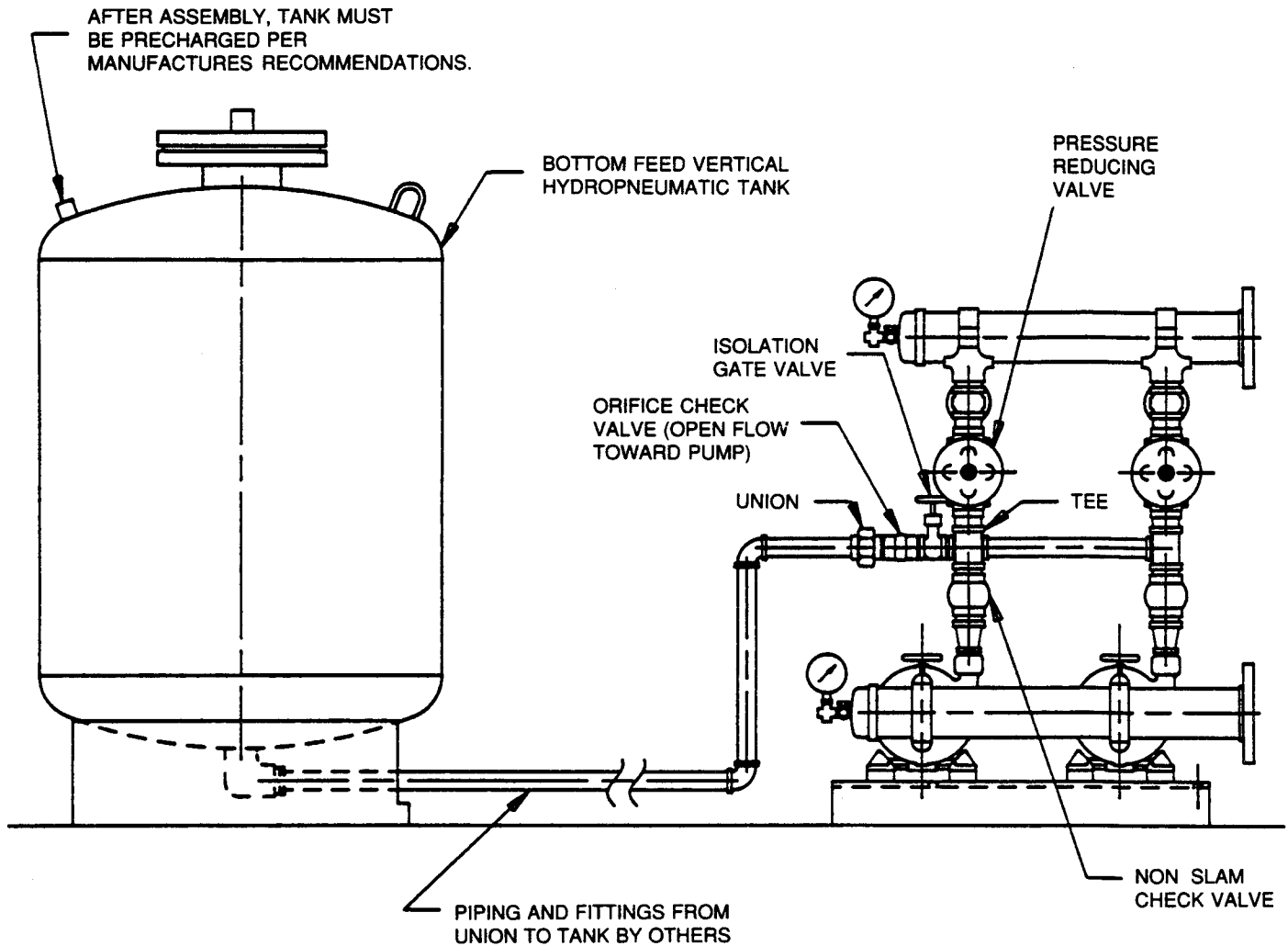

NOTE:

1. PARTS SHIPPED LOOSE FOR FIELD ASSEMBLY:
UNION
ORIFICE CHECK VALVE
ISOLATION VALVE
2. ADDITIONAL TANK PIPING BY OTHERS

**APCO-PM
 DUPLEX
 LOW & HIGH PRESSURE
 BOOSTER SYSTEMS
 3500 R.P.M.**

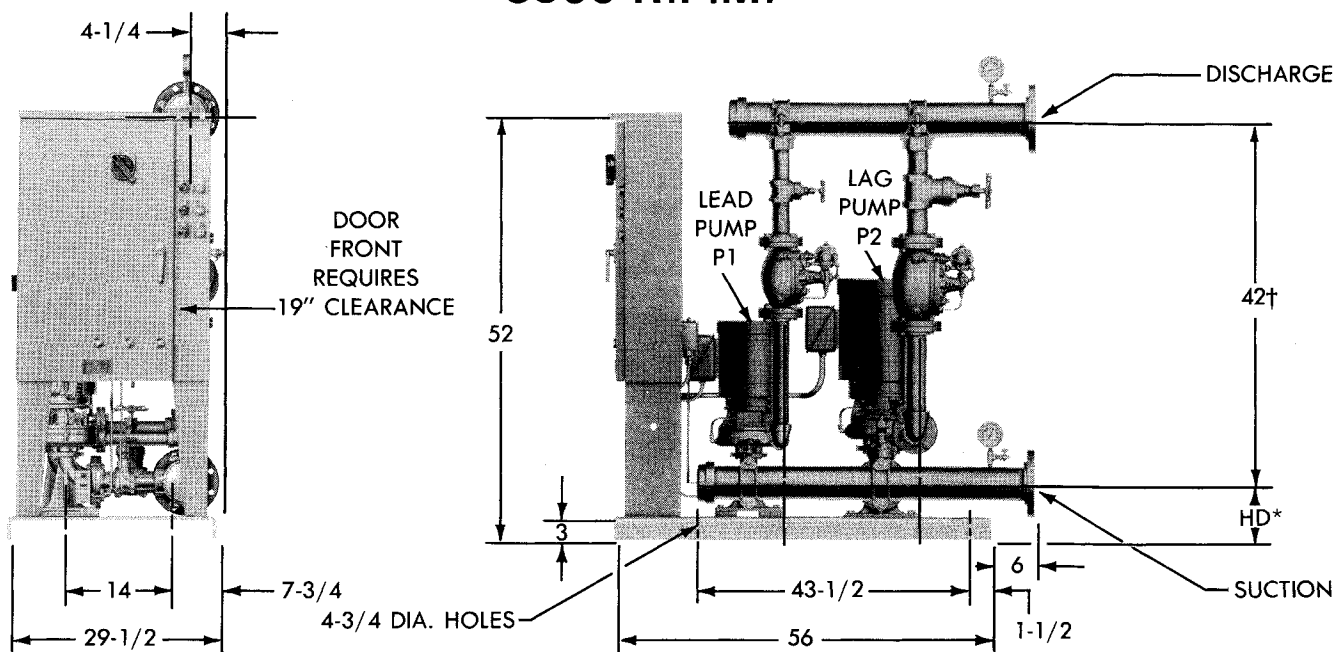

LOW PRESSURE

PUMP NO.		PUMP SIZE	HD*
P1	P2		
		1-1/4 x 1-1/2 x 7	6-3/4
		1-1/2 x 2 x 7	7-1/8
		2 x 2-1/2 x 7A	7-1/2
		2-1/2 x 3 x 7B	8

HIGH PRESSURE

PUMP NO.		PUMP SIZE	HD*
P1	P2		
		1-1/2 x 2 x 9C	7-1/8
		2 x 2-1/2 x 9	7-1/2

CAPACITY RANGE	FLANGED MANIFOLDS	
	SUCTION	DISCHARGE
0-200 G.P.M. FLOWS	4	3
200-400 G.P.M. FLOWS	4	4
400-800 G.P.M. FLOWS	5	5
600-800 G.P.M. FLOWS	6	6

NOTES:

1. ALL DIMENSIONS IN INCHES.
2. DIMENSIONS MAY VARY $\pm 1/2$.
3. NOT FOR CONSTRUCTION PURPOSES UNLESS CERTIFIED.
4. DISCHARGE AND SUCTION FLANGES AMERICAN STANDARD FLAT FACE 125#.
5. 1 GROUT HOLE IS PROVIDED IN TOP OF BASE.
6. WHEN MAKING SELECTIONS, DO NOT COMBINE LOW AND HIGH PRESSURE PUMPS.

*ALWAYS USE "HD" DIMENSION FOR LARGEST PUMP SIZE SPECIFIED.

†48" WHEN 4" PRV IS USED.

AURORA MODEL 753 PUMPS

APCO-PM TRI-PLEX

LOW & HIGH PRESSURE BOOSTER SYSTEMS

3500 R.P.M.

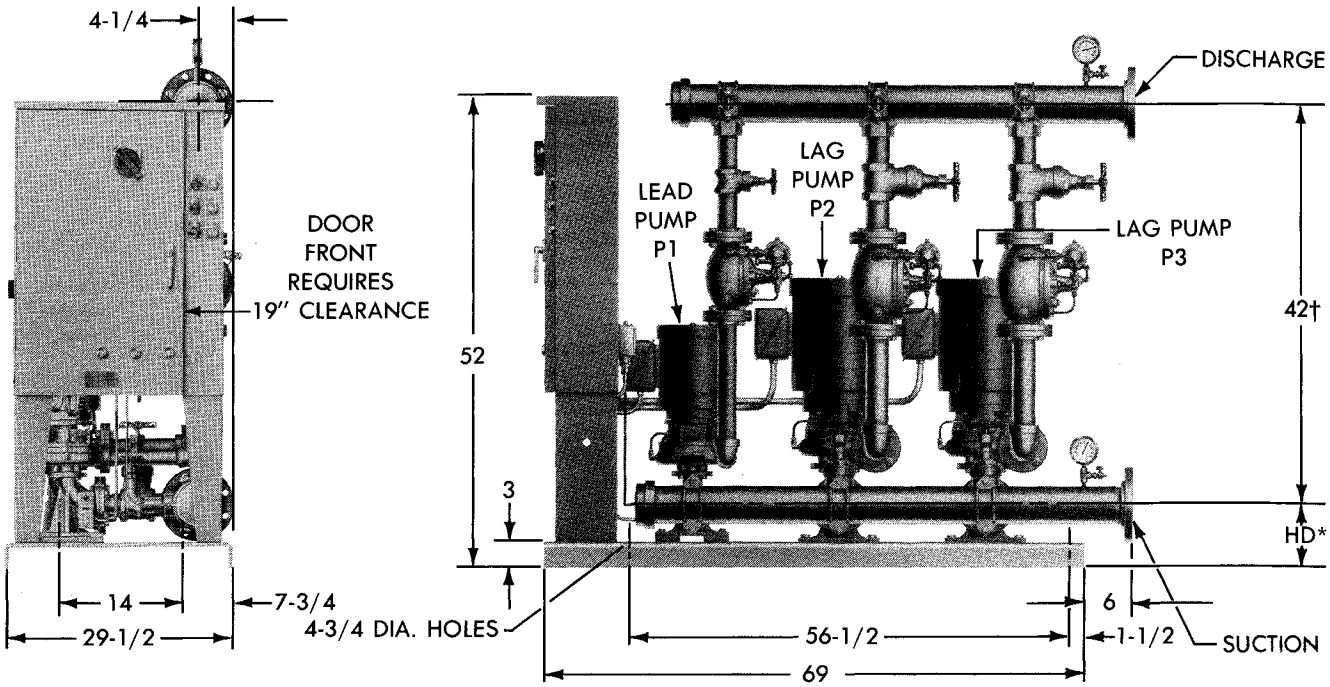

LOW PRESSURE

PUMP NO.			PUMP SIZE	HD*
P1	P2	P3		
			1-1/4 x 1-1/2 x 7	6-3/4
			1-1/2 x 2 x 7	7-1/8
			2 x 2-1/2 x 7A	7-1/2
			2-1/2 x 3 x 7B	8

HIGH PRESSURE

PUMP NO.			PUMP SIZE	HD*
P1	P2	P3		
			1-1/2 x 2 x 9C	7-1/8
			2 x 2-1/2 x 9	7-1/2

CAPACITY RANGE	FLANGED MANIFOLDS	
	SUCTION	DISCHARGE
0-400 G.P.M. FLOWS	4	4
400-600 G.P.M. FLOWS	5	5
600-1200 G.P.M. FLOWS	6	6

NOTES:

1. ALL DIMENSIONS IN INCHES.
2. DIMENSIONS MAY VARY ± 1/2.
3. NOT FOR CONSTRUCTION PURPOSES UNLESS CERTIFIED.
4. DISCHARGE AND SUCTION FLANGES AMERICAN STANDARD FLAT FACE 125#.
5. 2 GROUT HOLES ARE PROVIDED IN TOP OF BASE.
6. WHEN MAKING SELECTIONS, DO NOT COMBINE LOW AND HIGH PRESSURE PUMPS.

*ALWAYS USE "HD" DIMENSION FOR LARGEST PUMP SIZE SPECIFIED.

†48" WHEN 4" PRV IS USED.

**APCO-PM
 DUPLEX
 BOOSTER SYSTEMS
 1750 R.P.M.**

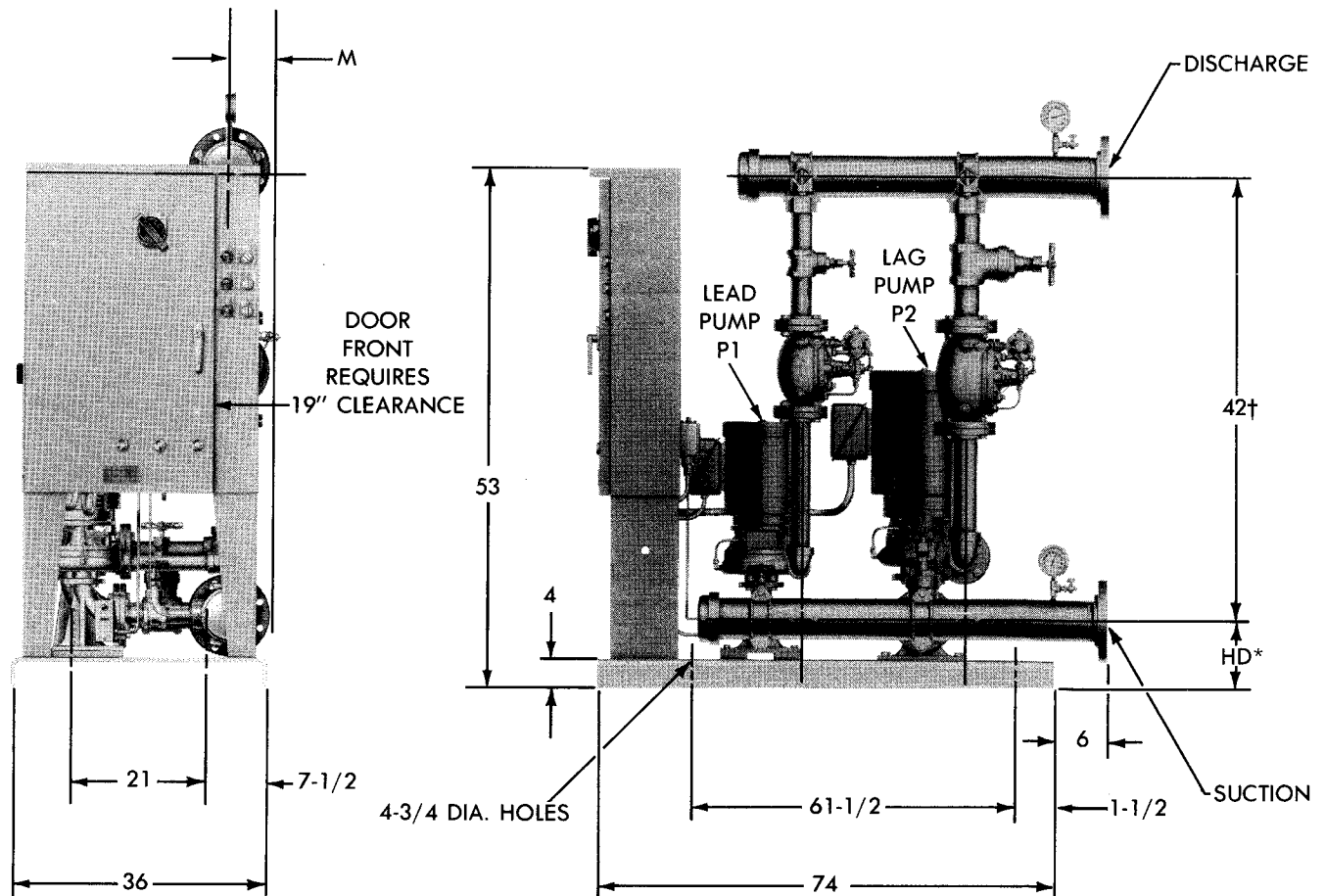

PUMP NO.		PUMP SIZE	HD*	M
P1	P2			
		2-1/2 x 3 x 9	9	4-1/4
		2 x 3 x 11	9	6
		1-1/2 x 2 x 12	8-1/8	6
		2-1/2 x 3 x 12	9	6

CAPACITY RANGE	FLANGED MANIFOLDS	
	SUCTION	DISCHARGE
0-200 G.P.M. FLOWS	4	3
200-400 G.P.M. FLOWS	4	4
400-600 G.P.M. FLOWS	5	5
600-900 G.P.M. FLOWS	6	6

NOTES:

1. ALL DIMENSIONS IN INCHES.
2. DIMENSIONS MAY VARY ± 1/2.
3. NOT FOR CONSTRUCTION PURPOSES UNLESS CERTIFIED.
4. DISCHARGE AND SUCTION FLANGES AMERICAN STANDARD FLAT FACE 125#.
5. 1 GROUT HOLE IS PROVIDED IN TOP OF BASE.
6. WHEN MAKING SELECTIONS, DO NOT MIX 1750 R.P.M. AND 3500 R.P.M. PUMPS.

*ALWAYS USE "HD" DIMENSION FOR LARGEST PUMP SIZE SPECIFIED.

†48" WHEN 4" PRV IS USED.

BOOSTER SYSTEMS WITH PRESSURE TANK

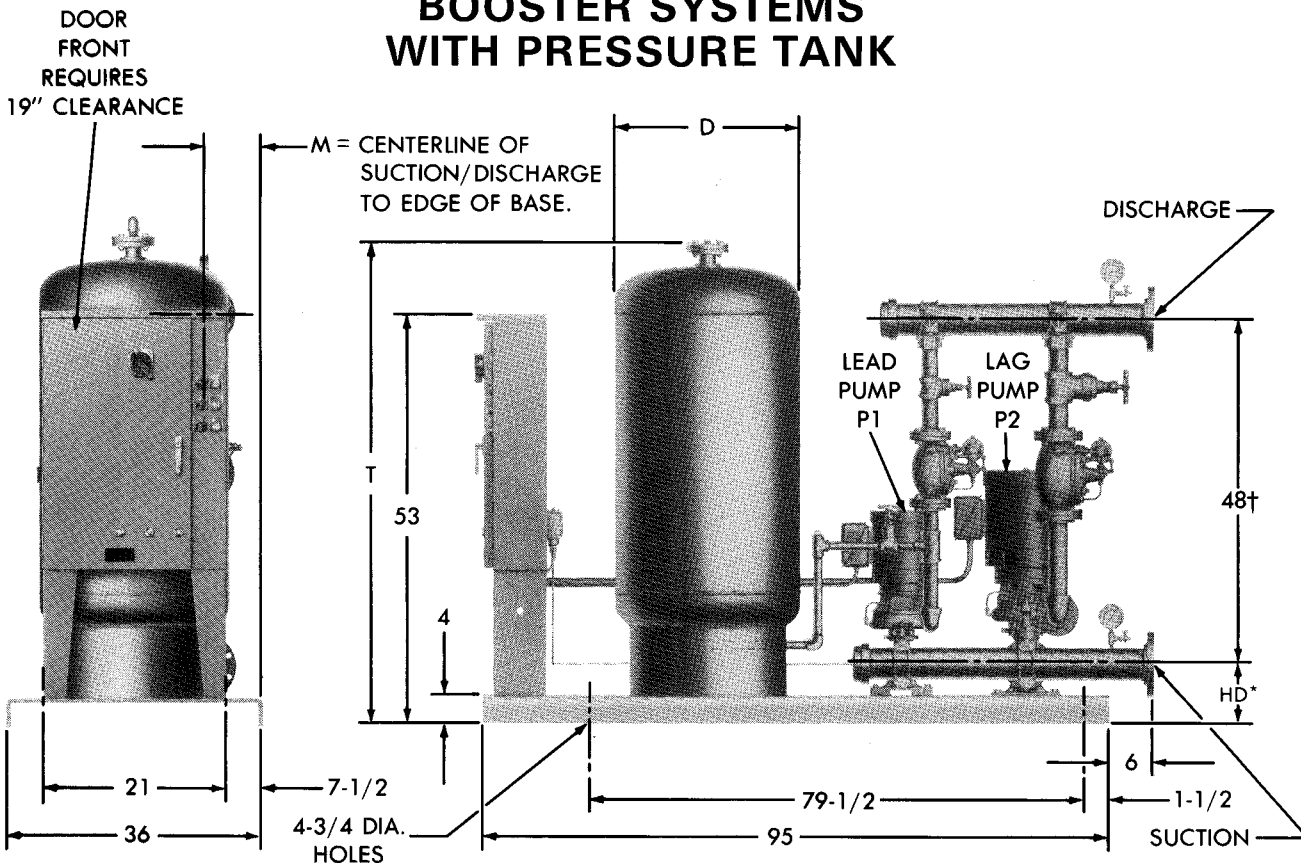

PUMP NO.		PUMP SIZE	HD*	M	R.P.M.
P1	P2				
		1-1/4 x 1-1/2 x 7	7-3/4	7-1/4	3500
		1-1/2 x 2 x 7	8-1/8	7-1/4	
		2 x 2-1/2 x 7A	8-1/2	7-1/4	
		2-1/2 x 3 x 7B	9	7-1/4	
		1-1/2 x 2 x 9C	8-1/8	7-1/4	
		2 x 2-1/2 x 9	8-1/2	7-1/4	
		2-1/2 x 3 x 9	9	7-1/4	1750
		2 x 3 x 11	9	5	
		1-1/2 x 2 x 12	8-1/8	6	
		2-1/2 x 3 x 12	9	5	

HYDRO PNEUMATIC TANKS						
TANK SIZE (GALLONS)	T	D	WEIGHT LBS.			
			125 PSI	175 PSI	200 PSI	250 PSI
79	59	24	271	325	-	400
106	53	30	300	343	-	435
132	61	30	330	349	-	465
158	69	30	360	436	-	500
170	80	30	-	-	575	-
211	67	36	513	626	-	813

CAPACITY RANGE	FLANGED MANIFOLDS	
	SUCTION	DISCHARGE
0-200 G.P.M. FLOWS	4	3
200-400 G.P.M. FLOWS	4	4
400-600 G.P.M. FLOWS	5	5
600-800 G.P.M. FLOWS	6	6

NOTES:

1. ALL DIMENSIONS IN INCHES.
2. DIMENSIONS MAY VARY ±1/2.
3. NOT FOR CONSTRUCTION PURPOSES UNLESS CERTIFIED.
4. DISCHARGE AND SUCTION FLANGES ANSI STANDARD FLAT FACE 125#.
5. 2 GROUT HOLES ARE PROVIDED IN TOP OF BASE.
6. WHEN MAKING SELECTIONS, DO NOT MIX 1750 R.P.M. AND 3500 R.P.M. PUMPS OR 7" AD 9" PUMPS.

*ALWAYS USE "HD" DIMENSION FOR LARGEST PUMP SIZE SPECIFIED.

†54" WHEN 4" PRV IS USED.

**BOOSTER SYSTEMS
WITH PRESSURE TANK**

DOOR
FRONT
REQUIRES
19" CLEARANCE

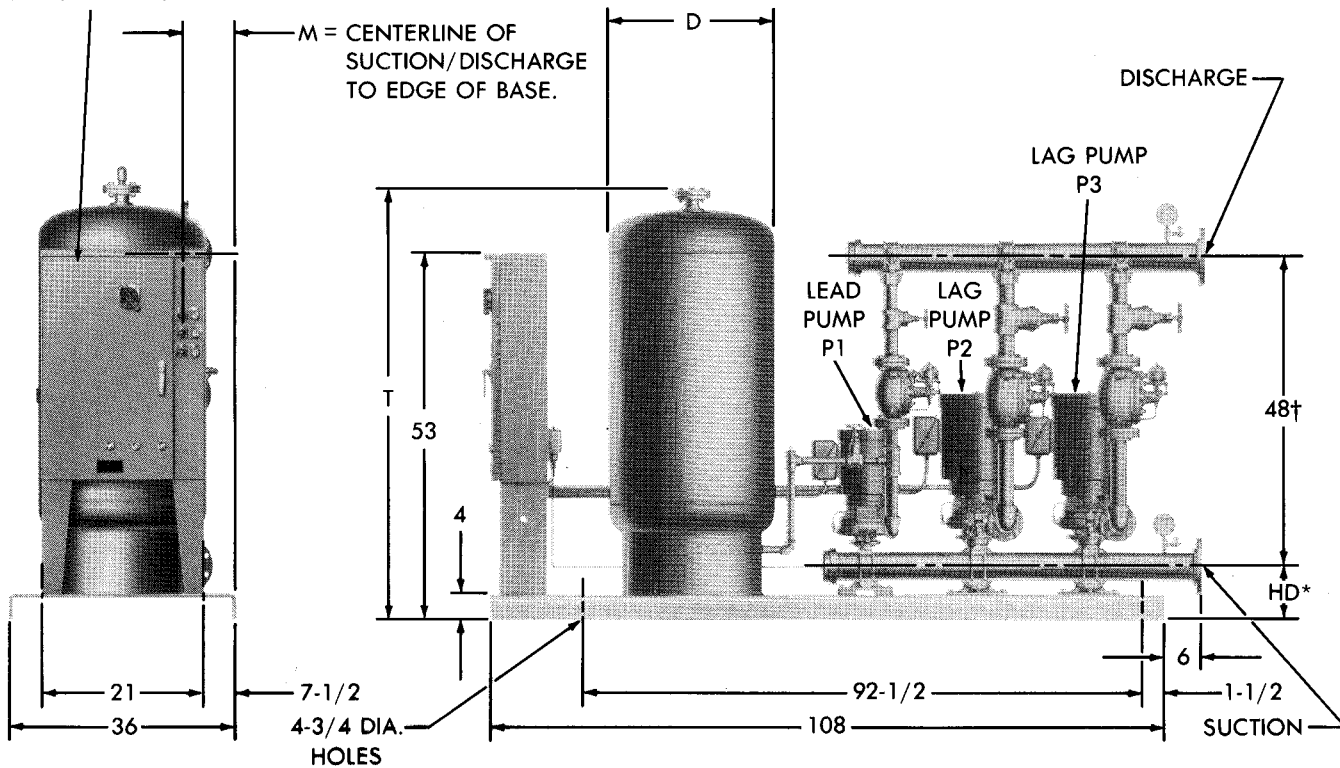

PUMP NO.			PUMP SIZE	HD*	M	R.P.M.
P1	P2	P3				
			1-1/4 x 1-1/2 x 7	7-3/4	7-1/4	3500
			1-1/2 x 2 x 7	8-1/8	7-1/4	
			2 x 2-1/2 x 7A	8-1/2	7-1/4	
			2-1/2 x 3 x 7B	9	7-1/4	
			1-1/2 x 2 x 9C	8-1/8	7-1/4	
			2 x 2-1/2 x 9	8-1/2	7-1/4	
			2-1/2 x 3 x 9	9	7-1/4	1750
			2 x 3 x 11	9	5	
			1-1/2 x 2 x 12	8-1/8	6	
			2-1/2 x 3 x 12	9	5	

HYDRO PNEUMATIC TANKS						
TANK SIZE (GALLONS)	T	D	WEIGHT LBS.			
			125 PSI	175 PSI	200 PSI	250 PSI
79	59	24	271	325	-	400
106	53	30	300	343	-	435
132	61	30	330	349	-	465
158	69	30	360	436	-	500
170	80	30	-	-	575	-
211	67	36	513	626	-	813

CAPACITY RANGE	FLANGED MANIFOLDS	
	SUCTION	DISCHARGE
0-400 G.P.M. FLOWS	4	4
400-600 G.P.M. FLOWS	5	5
600-1200 G.P.M. FLOWS	6	6

NOTES:

1. ALL DIMENSIONS IN INCHES.
2. DIMENSIONS MAY VARY ±1/2.
3. NOT FOR CONSTRUCTION PURPOSES UNLESS CERTIFIED.
4. DISCHARGE AND SUCTION FLANGES ANSI STANDARD FLAT FACE 125#.
5. 2 GROUT HOLES ARE PROVIDED IN TOP OF BASE.
6. WHEN MAKING SELECTIONS, DO NOT MIX 1750 R.P.M. AND 3500 R.P.M. PUMPS OR 7" AD 9" PUMPS.

*ALWAYS USE "HD" DIMENSION FOR LARGEST PUMP SIZE SPECIFIED.

†54" WHEN 4" PRV IS USED.

AURORA - PC

DATED AUGUST 1987

DUPLEX - 3500 R.P.M. PRESSURE CONTROL SYSTEMS

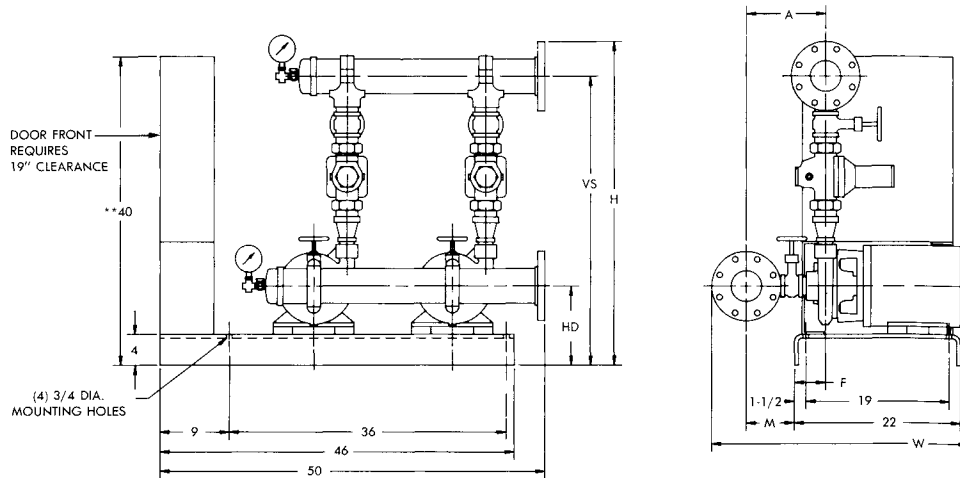

PUMP SIZE	MTR. FR.	H.P.	P R V	HD	VS	H	A	F	M	W	SUCTION & DISCHARGE MANIFOLDS
1-1/4 x 1-1/2 x 7 3500 R.P.M.	145	2	A	10-1/4	34-5/16	38-13/16	10-11/16	9-7/16	1-1/4	33-3/8	4
	145	2	G	10-1/4	31-3/8	35-7/8	10-11/16	9-7/16	1-1/4	33-3/8	
	182	3	A	10-1/4	34-5/16	38-13/16	10-11/16	9-7/16	1-1/4	33-3/8	
	182	3	G	10-1/4	31-3/8	35-7/8	10-11/16	9-7/16	1-1/4	33-3/8	
	182	3	B	10-1/4	37	41-1/2	10-11/16	9-7/16	1-1/4	33-3/8	
	182	3	H	10-1/4	34-9/16	39-1/16	10-11/16	9-7/16	1-1/4	33-3/8	
	182	3	C	10-1/4	38-7/16	42-15/16	10-11/16	9-7/16	1-1/4	33-3/8	
	182	3	D	10-1/4	39-7/8	44-3/8	10-11/16	9-7/16	1-1/4	33-3/8	
	184	5	A	10-1/4	34-5/16	38-13/16	10-11/16	9-7/16	1-1/4	33-3/8	
	184	5	G	10-1/4	31-3/8	35-7/8	10-11/16	9-7/16	1-1/4	33-3/8	
	184	5	B	10-1/4	37	41-1/2	10-11/16	9-7/16	1-1/4	33-3/8	
	184	5	H	10-1/4	34-9/16	39-1/16	10-11/16	9-7/16	1-1/4	33-3/8	
	184	5	C	10-1/4	38-7/16	42-15/16	10-11/16	9-7/16	1-1/4	33-3/8	
	184	5	D	10-1/4	39-7/8	44-3/8	10-11/16	9-7/16	1-1/4	33-3/8	
	213	7-1/2	B	10-1/4	37	41-1/2	10-11/16	4-1/8	6-9/16	35-1/16	
	213	7-1/2	H	10-1/4	34-9/16	39-1/16	10-11/16	4-1/8	6-9/16	35-1/16	
213	7-1/2	C	10-1/4	38-7/16	42-15/16	10-11/16	4-1/8	6-9/16	35-1/16		
213	7-1/2	D	10-1/4	39-7/8	44-3/8	10-11/16	4-1/8	6-9/16	35-1/16		
1-1/2 x 2 x 7 3500 R.P.M.	184	5	D	10-1/4	39-3/4	44-1/4	11-1/16	9-3/8	1-11/16	33-13/16	4
	184	5	E	10-1/4	42-7/8	47-3/8	11-1/16	9-3/8	1-11/16	33-13/16	
	213	7-1/2	C	10-1/4	38-11/16	43-3/16	11-1/16	4-1/16	7	35-1/2	
	213	7-1/2	D	10-1/4	39-3/4	44-1/4	11-1/16	4-1/16	7	35-1/2	
	213	7-1/2	E	10-1/4	42-7/8	47-3/8	11-1/16	4-1/16	7	35-1/2	
	215	10	C	10-1/4	38-11/16	43-3/16	11-1/16	3-5/16	7-3/4	37-1/2	
	215	10	D	10-1/4	39-3/4	44-1/4	11-1/16	3-5/16	7-3/4	37-1/2	
215	10	E	10-1/4	42-7/8	47-3/8	11-1/16	3-5/16	7-3/4	37-1/2		
2 x 2-1/2 x 7A 3500 R.P.M.	184	5	F	10-1/4	41-13/16	46-5/16	12	9-1/4	2-3/4	34-7/8	4
	213	7-1/2	F	10-1/4	41-13/16	46-5/16	12	3-15/16	8-1/16	36-9/16	
	215	10	F	10-1/4	41-13/16	46-5/16	12	3-3/16	8-13/16	38-9/16	
	254	15	E	10-1/4	40	44-1/2	12	13/16	11-3/16	40-9/16	
	254	15	F	10-1/4	41-13/16	46-5/16	12	13/16	11-3/16	40-9/16	5
	256	20	F	10-1/4	41-13/16	46-5/16	12	9/16†	12-9/16	44-9/16	
	213	7-1/2	F	10-1/4	42-13/16	47-13/16	12-3/4	3-15/16	8-13/16	37-13/16	6
	215	10	F	10-1/4	42-13/16	47-13/16	12-3/4	3-3/16	9-9/16	39-13/16	
	254	15	F	10-1/4	42-13/16	47-13/16	12-3/4	13/16	11-15/16	41-13/16	6
	256	20	F	10-1/4	42-13/16	47-13/16	12-3/4	9/16†	13-5/16	45-13/16	
	213	7-1/2	F	10-1/4	43-5/16	48-13/16	13-1/8	3-15/16	9-3/16	38-11/16	6
	215	10	F	10-1/4	43-5/16	48-13/16	13-1/8	3-3/16	9-15/16	40-11/16	
	254	15	F	10-1/4	43-5/16	48-13/16	13-1/8	13/16	12-5/16	42-11/16	
	256	20	F	10-1/4	43-5/16	48-13/16	13-1/8	9/16†	13-11/16	46-11/16	

NOTES:

- ALL DIMENSIONS IN INCHES.
- DIMENSIONS MAY VARY ± 1/2.
- NOT FOR CONSTRUCTION PURPOSES UNLESS CERTIFIED.
- DISCHARGE AND SUCTION FLANGES AMERICAN STANDARD FLAT FACE 125#.
- 1 GROUT HOLE IS PROVIDED IN TOP OF BASE.

PRESSURE REDUCING VALVES									
DIRECT ACTING					PILOT OPERATED				
SIZE	1-1/2	2	2-1/2	2	2-1/2	3	1-1/4	1-1/2	4
CODE	A	B	C	D	E	F	G	H	J

†DISCHARGE CENTERLINE, "F" DIMENSION IS LEFT OF BASE FOR THESE PUMP SELECTIONS ONLY.

**PANEL HEIGHT 48" ON 208 VOLT 15 H.P. AND 20 H.P. ALSO 230 VOLT 20 H.P.

**AURORA - PC
 DUPLEX - 3500 R.P.M.
 PRESSURE CONTROL SYSTEMS**

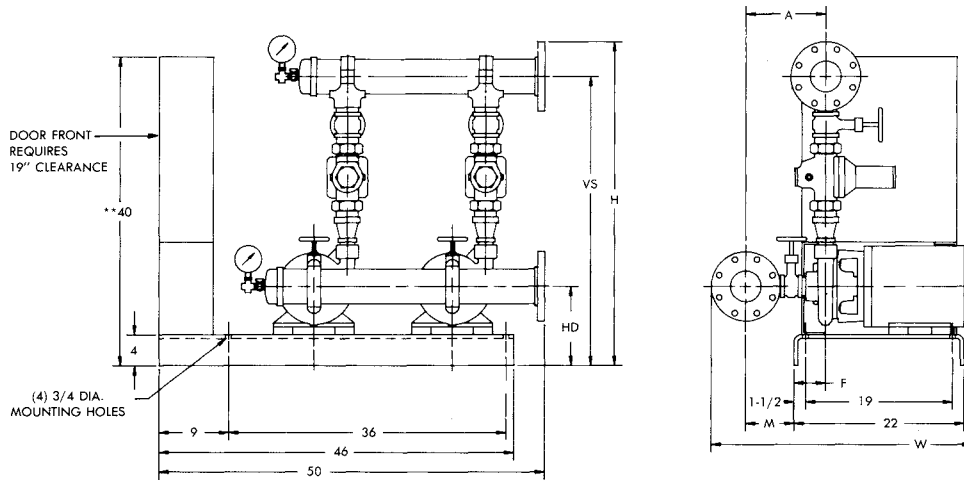

PUMP SIZE	MTR. FR.	H.P.	P R V	HD	VS	H	A	F	M	W	SUCTION & DISCHARGE MANIFOLDS
2-1/2 x 3 x 7B 3500 R.P.M.	254	15	F	11-1/4	43-13/16	48-5/16	13-1/16	11/16	12-3/8	41-3/4	4
	254	15	F	11-1/4	44-5/16	49-5/16	13-9/16	11/16	12-7/8	42-3/4	5
	256	20	F	11-1/4	44-5/16	49-5/16	13-9/16	11/16†	14-1/4	46-3/4	6
	215	10	J	11-1/4	52-5/16	57-13/16	14-1/16	3-1/16	11	41-3/4	
	254	15	J	11-1/4	52-5/16	57-13/16	14-1/16	11/16	13-3/8	43-3/4	
	256	20	J	11-1/4	52-5/16	57-13/16	14-1/16	11/16†	14-3/4	47-3/4	
	254	15	F	11-1/4	44-13/16	50-5/16	14-1/16	11/16	13-3/8	43-3/4	
256	20	F	11-1/4	44-13/16	50-5/16	14-1/16	11/16†	14-3/4	47-3/4		
1-1/2 x 2 x 9C 3500 R.P.M.	213	7-1/2	B	11-1/4	39-5/8	44-1/8	11-3/16	4-1/16	7-1/8	35-5/8	4
	213	7-1/2	H	11-1/4	34	38-1/2	11-3/16	4-1/16	7-1/8	35-5/8	
	215	10	B	11-1/4	39-5/8	44-1/8	11-3/16	3-5/16	7-7/8	37-5/8	
	215	10	C	11-1/4	41-1/16	45-9/16	11-3/16	3-5/16	7-7/8	37-5/8	
	215	10	D	11-1/4	42-1/8	46-5/8	11-3/16	3-5/16	7-7/8	37-5/8	
	215	10	H	11-1/4	34	38-1/2	11-3/16	3-5/16	7-7/8	37-5/8	
	254	15	B	11-1/4	39-5/8	44-1/8	11-3/16	15/16	10-1/4	39-5/8	
	254	15	C	11-1/4	41-1/16	45-9/16	11-3/16	15/16	10-1/4	39-5/8	
	254	15	D	11-1/4	42-1/8	46-5/8	11-3/16	15/16	10-1/4	39-5/8	
	254	15	E	11-1/4	45-1/4	49-3/4	11-3/16	15/16	10-1/4	39-5/8	
	254	15	H	11-1/4	34	38-1/2	11-3/16	15/16	10-1/4	39-5/8	
	256	20	C	11-1/4	41-1/16	45-9/16	11-3/16	7/16†	11-5/8	43-5/8	
	256	20	D	11-1/4	42-1/8	46-5/8	11-3/16	7/16†	11-5/8	43-5/8	
	256	20	E	11-1/4	45-1/4	49-3/4	11-3/16	7/16†	11-5/8	43-5/8	
2 x 2-1/2 x 9 3500 R.P.M.	254	15	F	11-3/4	45-3/16	49-11/16	12	13/16	11-3/16	40-9/16	4
	256	20	F	11-3/4	45-3/16	49-11/16	12	9/16†	12-9/16	44-9/16	5
	254	15	F	11-3/4	45-11/16	50-11/16	12-3/4	13/16	11-15/16	41-13/16	
	256	20	F	11-3/4	45-11/16	50-11/16	12-3/4	9/16†	13-5/16	45-13/16	
	254	15	F	11-3/4	46-3/16	51-11/16	13-1/8	13/16	12-5/16	42-11/16	6
256	20	F	11-3/4	46-3/16	51-11/16	13-1/8	9/16†	13-11/16	46-11/16		

- NOTES:
 1. ALL DIMENSIONS IN INCHES.
 2. DIMENSIONS MAY VARY ± 1/2.
 3. NOT FOR CONSTRUCTION PURPOSES UNLESS CERTIFIED.
 4. DISCHARGE AND SUCTION FLANGES AMERICAN STANDARD FLAT FACE 125#.
 5. 1 GROUT HOLE IS PROVIDED IN TOP OF BASE.

PRESSURE REDUCING VALVES									
DIRECT ACTING					PILOT OPERATED				
SIZE	1-1/2	2	2-1/2	3	1-1/4	1-1/2	2	2-1/2	3
CODE	A	B	C	D	E	F	G	H	J

†DISCHARGE CENTERLINE, "F" DIMENSION IS LEFT OF BASE FOR THESE PUMP SELECTIONS ONLY.

**PANEL HEIGHT 48" ON 208 VOLT 15 H.P. AND 20 H.P. ALSO 230 VOLT 20 H.P.

AURORA MODEL 762 PUMPS

AURORA - PC

DUPLEX - 1750 R.P.M. PRESSURE CONTROL SYSTEMS

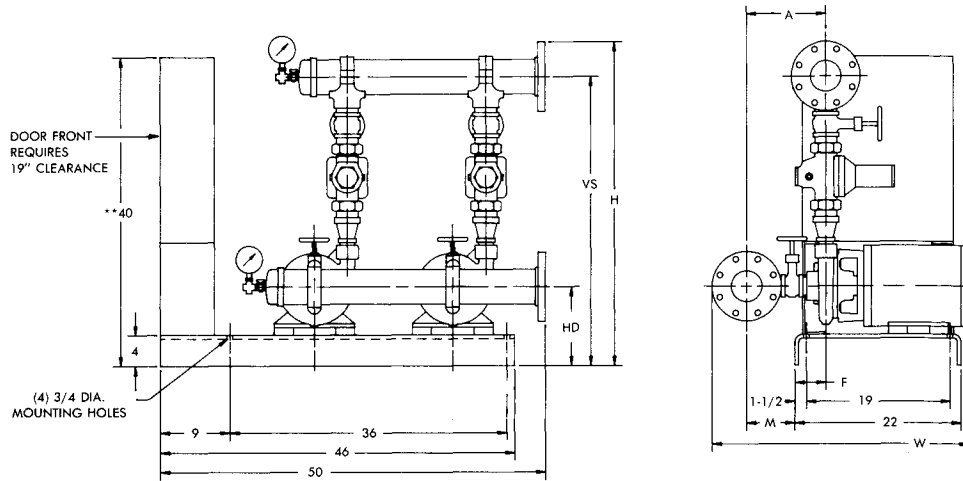

PUMP SIZE	MTR. FR.	H.P.	P R V	HD	VS	H	A	F	M	W	SUCTION & DISCHARGE MANIFOLDS
1-1/2 x 2 x 9C 1750 R.P.M.	143	1	A	11-1/4	33-7/8	38-3/8	11-3/16	10-3/16	1	32-7/8	4
	143	1	B	11-1/4	39-5/8	44-1/8	11-3/16	10-3/16	1	32-7/8	
	143	1	G	11-1/4	36-15/16	41-1/16	11-3/16	10-3/16	1	32-7/8	
	143	1	H	11-1/4	34	38-1/2	11-3/16	10-3/16	1	32-7/8	
	145	1-1/2	A	11-1/4	33-7/8	38-3/8	11-3/16	10-3/16	1	33-7/8	
	145	1-1/2	B	11-1/4	39-5/8	44-1/8	11-3/16	10-3/16	1	33-7/8	
	145	1-1/2	G	11-1/4	36-15/16	41-1/16	11-3/16	10-3/16	1	33-7/8	
	145	1-1/2	H	11-1/4	34	38-1/2	11-3/16	10-3/16	1	33-7/8	
	145	2	A	11-1/4	33-7/8	38-3/8	11-3/16	10-3/16	1	33-7/8	
	145	2	B	11-1/4	39-5/8	44-1/8	11-3/16	10-3/16	1	33-7/8	
	145	2	C	11-1/4	41-1/16	45-9/16	11-3/16	10-3/16	1	33-7/8	
	145	2	D	11-1/4	42-1/8	46-5/8	11-3/16	10-3/16	1	33-7/8	
	145	2	G	11-1/4	36-15/16	41-7/16	11-3/16	10-3/16	1	33-7/8	
	145	2	H	11-1/4	34	38-1/2	11-3/16	10-3/16	1	33-7/8	
	182	3	A	11-1/4	33-7/8	38-3/8	11-3/16	10-3/16	1	33-7/8	
	182	3	B	11-1/4	39-5/8	44-1/8	11-3/16	10-3/16	1	33-7/8	
	182	3	C	11-1/4	41-1/16	45-9/16	11-3/16	10-3/16	1	33-7/8	
	182	3	D	11-1/4	42-1/8	46-5/8	11-3/16	10-3/16	1	33-7/8	
182	3	G	11-1/4	36-15/16	41-7/16	11-3/16	10-3/16	1	33-7/8		
182	3	H	11-1/4	34	38-1/2	11-3/16	10-3/16	1	33-7/8		
2 x 2-1/2 x 9 1750 R.P.M.	145	2	C	11-3/4	42-9/16	47-1/16	12	9-5/16	2-11/16	34-13/16	4
	145	2	D	11-3/4	37-11/16	42-3/16	12	9-5/16	2-11/16	34-13/16	
	145	2	E	11-3/4	42-7/8	47-3/8	12	9-5/16	2-11/16	34-13/16	
	182	3	B	11-3/4	37-11/16	42-3/16	12	9-5/16	2-11/16	34-13/16	
	182	3	C	11-3/4	42-9/16	47-1/16	12	9-5/16	2-11/16	34-13/16	
	182	3	D	11-3/4	37-11/16	42-3/16	12	9-5/16	2-11/16	34-13/16	
	182	3	E	11-3/4	42-7/8	47-3/8	12	9-5/16	2-11/16	34-13/16	
	182	3	H	11-3/4	38-5/16	42-13/16	12	9-5/16	2-11/16	34-13/16	
	184	5	C	11-3/4	42-9/16	47-1/16	12	9-5/16	2-11/16	34-13/16	
	184	5	D	11-3/4	37-11/16	42-3/16	12	9-5/16	2-11/16	34-13/16	
184	5	E	11-3/4	42-7/8	47-3/8	12	9-5/16	2-11/16	34-13/16		

NOTES:

1. ALL DIMENSIONS IN INCHES.
2. DIMENSIONS MAY VARY ± 1/2.
3. NOT FOR CONSTRUCTION PURPOSES UNLESS CERTIFIED.
4. DISCHARGE AND SUCTION FLANGES AMERICAN STANDARD FLAT FACE 125#.
5. 1 GROUT HOLE IS PROVIDED IN TOP OF BASE.

PRESSURE REDUCING VALVES										
DIRECT ACTING					PILOT OPERATED					
SIZE	1-1/2	2	2-1/2	3	2	2-1/2	3	1-1/4	1-1/2	4
CODE	A	B	C	D	E	F	G	H	J	

**PANEL HEIGHT 48" ON 208 VOLT 15 H.P. AND 20 H.P.
ALSO 230 VOLT 20 H.P.

AURORA MODEL 762 PUMPS

AURORA - PC

DUPLEX - 1750 R.P.M.

PRESSURE CONTROL SYSTEMS

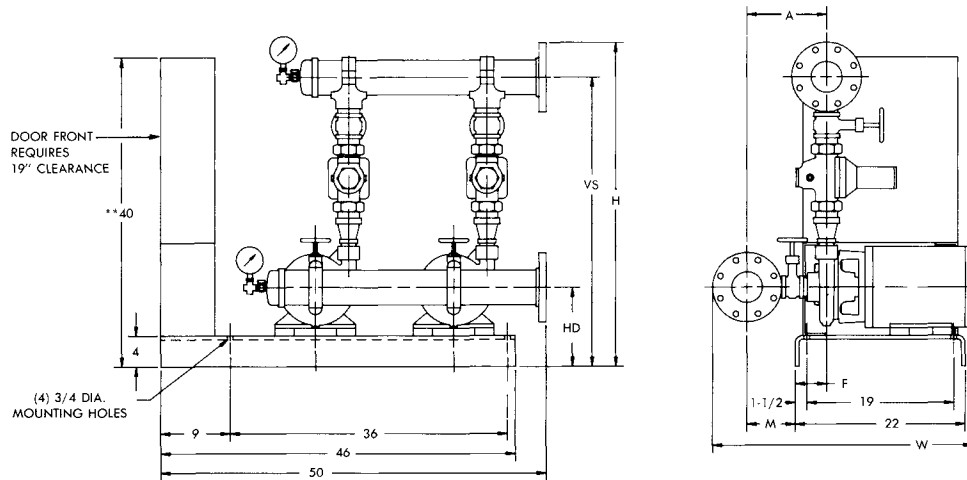

PUMP SIZE	MTR. FR.	H.P.	P R V	HD	VS	H	A	F	M	W	SUCTION & DISCHARGE MANIFOLDS		
2-1/2 x 3 x 9 1750 R.P.M.	182	3	C	11-3/4	38-13/16	43-5/16	13-1/16	9-3/16	3-7/8	36	4		
	182	3	D	11-3/4	40-15/16	45-7/16	13-1/16	9-3/16	3-7/8	36			
	182	3	E	11-3/4	40-1/8	44-5/8	13-1/16	9-3/16	3-7/8	36			
	182	3	F	11-3/4	45-11/16	50-3/16	13-1/16	9-3/16	3-7/8	36			
	184	5	C	11-3/4	38-13/16	43-5/16	13-1/16	9-3/16	3-7/8	36			
	184	5	D	11-3/4	40-15/16	45-7/16	13-1/16	9-3/16	3-7/8	36			
	184	5	E	11-3/4	40-1/8	44-5/8	13-1/16	9-3/16	3-7/8	36			
	184	5	F	11-3/4	45-11/16	50-3/16	13-1/16	9-3/16	3-7/8	36			
	213	7-1/2	F	11-3/4	45-11/16	50-3/16	13-1/16	3-13/16	9-1/4	37-3/4			
	182	3	E	11-3/4	40-7/8	45-7/8	13-9/16	9-3/16	3-7/8	36-1/2		5	
	182	3	F	11-3/4	46-3/16	51-3/16	13-9/16	9-3/16	3-7/8	36-1/2			
	184	5	E	11-3/4	40-7/8	45-7/8	13-9/16	9-3/16	3-7/8	36-1/2			
	184	5	F	11-3/4	46-3/16	51-3/16	13-9/16	9-3/16	3-7/8	36-1/2			
	2 x 3 x 11 1750 R.P.M.	213	7-1/2	F	11-3/4	46-3/16	51-3/16	13-9/16	3-13/16	9-3/4		38-1/4	6
		184	5	F	11-3/4	46-11/16	52-3/16	14-1/16	9-3/16	3-7/8		37	
213		7-1/2	F	11-3/4	46-11/16	52-3/16	14-1/16	3-13/16	10-1/4	38-3/4			
213		7-1/2	C	12-1/4	44-1/16	48-9/16	13-7/16	3-7/8	9-9/16	38-1/16	4		
213		7-1/2	D	12-1/4	39-3/16	43-11/16	13-7/16	3-7/8	9-9/16	38-1/16			
213		7-1/2	E	12-1/4	44-3/8	48-7/8	13-7/16	3-7/8	9-9/16	38-1/16			
215		10	E	12-1/4	44-3/8	48-7/8	13-7/16	3-1/8	10-5/16	40-1/16			
213	7-1/2	F	12-1/4	46-11/16	51-3/16	13-7/16	3-7/8	9-9/16	38-1/16				
213	7-1/2	F	12-1/4	47-3/16	52-3/16	13-15/16	3-7/8	10-1/16	38-1/16	5			
215	10	F	12-1/4	47-3/16	52-3/16	13-15/16	3-1/8	10-13/16	40-1/16				
1-1/2 x 2 x 12 1750 R.P.M.	213	7-1/2	F	12-1/4	47-11/16	53-3/16	14-7/16	3-7/8	10-9/16	38-1/16	4		
	215	10	F	12-1/4	47-11/16	53-3/16	14-7/16	3-1/8	11-5/16	40-1/16			
	213	7-1/2	A	13	36-5/8	41-1/8	11-5/16	3-15/16	7-3/8	35-7/8			
	213	7-1/2	G	13	39-11/16	44-3/16	11-5/16	3-15/16	7-3/8	35-7/8			
	213	7-1/2	B	13	42-3/8	46-7/8	11-5/16	3-15/16	7-3/8	35-7/8			
	213	7-1/2	H	13	36-3/4	41-1/4	11-5/16	3-15/16	7-3/8	35-7/8			
	213	7-1/2	C	13	43-9/16	48-1/16	11-5/16	3-15/16	7-3/8	35-7/8			
	213	7-1/2	D	13	45-1/4	49-3/4	11-5/16	3-15/16	7-3/8	35-7/8			
	213	7-1/2	E	13	48	52-1/2	11-5/16	3-15/16	7-3/8	35-7/8			
	215	10	C	13	43-9/16	48-1/16	11-5/16	3-3/16	8-1/8	37-7/8			
	215	10	D	13	45-1/4	49-3/4	11-5/16	3-3/16	8-1/8	37-7/8			
215	10	E	13	48	52-1/2	11-5/16	3-3/16	8-1/8	37-7/8				

- NOTES:
- ALL DIMENSIONS IN INCHES.
 - DIMENSIONS MAY VARY ± 1/2.
 - NOT FOR CONSTRUCTION PURPOSES UNLESS CERTIFIED.
 - DISCHARGE AND SUCTION FLANGES AMERICAN STANDARD FLAT FACE 125#.
 - 1 GROUT HOLE IS PROVIDED IN TOP OF BASE.

PRESSURE REDUCING VALVES									
DIRECT ACTING					PILOT OPERATED				
SIZE	1-1/2	2	2-1/2	2	2-1/2	3	1-1/4	1-1/2	4
CODE	A	B	C	D	E	F	G	H	J

**PANEL HEIGHT 48" ON 208 VOLT 15 H.P. AND 20 H.P.
 ALSO 230 VOLT 20 H.P.

AURORA MODEL 762 PUMPS

AURORA - PC

DUPLEX - 1750 R.P.M.

PRESSURE CONTROL SYSTEMS

SECTION 750/760 PAGE 213

DATED JANUARY 1999

SUPERSEDES PAGE 213

DATED AUGUST 1987

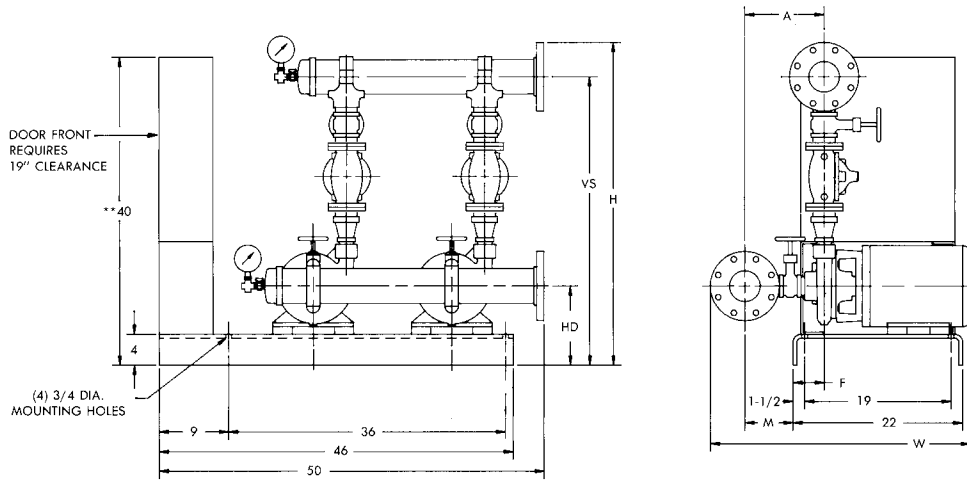

PUMP SIZE	MTR. FR.	H.P.	P R V	HD	VS	H	A	F	M	W	SUCTION & DISCHARGE MANIFOLDS
2-1/2 x 3 x 12 1750 R.P.M.	254	15	DP	13-1/4	42-5/8	47-1/8	13-1/16	9/16	12-1/2	41-7/8	4
	213	7-1/2	EP	13-1/4	48-3/16	52-11/16	13-1/16	3-11/16	9-3/8	37-7/8	
	215	10	EP	13-1/4	48-3/16	52-11/16	13-1/16	2-15/16	10-1/8	39-7/8	
	254	15	EP	13-1/4	48-3/16	52-11/16	13-1/16	9/16	12-1/2	41-7/8	
	213	7-1/2	EP	13-1/4	48-11/16	53-11/16	13-9/16	3-11/16	9-7/8	38-7/8	5
	215	10	EP	13-1/4	48-11/16	53-11/16	13-9/16	2-15/16	10-5/8	40-7/8	
	254	15	EP	13-1/4	48-11/16	53-11/16	13-9/16	9/16	13	42-7/8	
	256	20	EP	13-1/4	48-11/16	53-11/16	13-9/16	13/16†	14-3/8	46-7/8	
	215	10	EP	13-1/4	49-3/16	54-11/16	14-1/16	2-15/16	11-1/8	41-7/8	6
	254	15	EP	13-1/4	49-3/16	54-11/16	14-1/16	9/16	13-1/2	43-7/8	
	256	20	EP	13-1/4	49-3/16	54-11/16	14-1/16	13/16†	14-7/8	47-7/8	
	254	15	FP	13-1/4	56-11/16	62-3/16	14-1/16	9/16	13-1/2	43-7/8	
256	20	FP	13-1/4	56-11/16	62-3/16	14-1/16	13/16†	14-7/8	47-7/8		

NOTES:

1. ALL DIMENSIONS IN INCHES.
2. DIMENSIONS MAY VARY ±1/2.
3. NOT FOR CONSTRUCTION PURPOSES UNLESS CERTIFIED.
4. DISCHARGE AND SUCTION FLANGES ANSI STANDARD FLAT FACE 125#.
5. 1 GROUT HOLE IS PROVIDED IN TOP OF BASE.

PRESSURE REDUCING VALVES									
DIRECT ACTING					PILOT OPERATED				
SIZE	1-1/2	2	2-1/2	2	2-1/2	3	1-1/4	1-1/2	4
CODE	27AA	27AB	27AC	CP	DP	EP	AP	BP	FP

†DISCHARGE CENTERLINE, "F" DIMENSION IS LEFT OF BASE FOR THESE PUMP SELECTIONS ONLY.

**PANEL HEIGHT 48" ON 208 VOLT 15 H.P. AND 20 H.P. ALSO 230 VOLT 20 H.P.

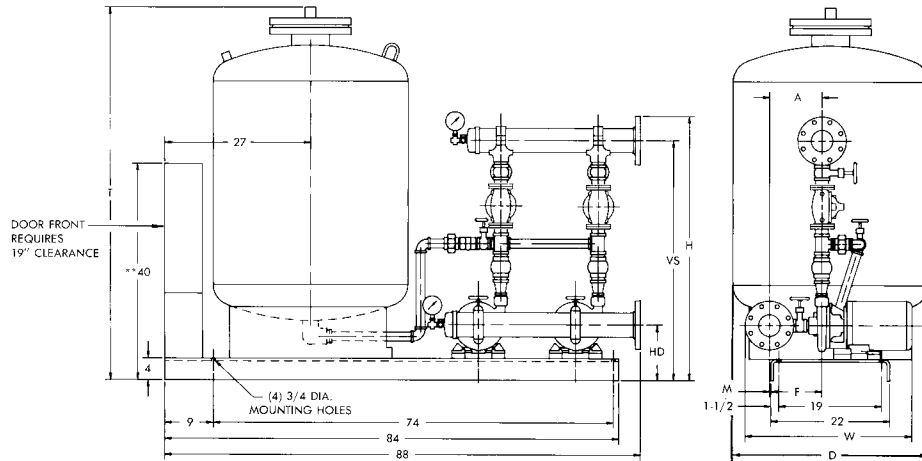

PUMP SIZE	MTR. FR.	H.P.	P R V	HD	VS	H	A	F	M	W	SUCTION & DISCHARGE MANIFOLDS
1-1/4 x 1-1/2 x 7 3500 R.P.M.	145	2	27AA	10-1/4	44-5/16	48-13/16	10-11/16	9-7/16	1-1/4	33-3/8	4
	145	2	AP	10-1/4	40-7/8	45-5/8	10-11/16	9-7/16	1-1/4	33-3/8	
	182	3	27AA	10-1/4	44-5/16	48-13/16	10-11/16	9-7/16	1-1/4	33-3/8	
	182	3	AP	10-1/4	40-7/8	45-5/8	10-11/16	9-7/16	1-1/4	33-3/8	
	182	3	27AB	10-1/4	48-3/16	52-11/16	10-11/16	9-7/16	1-1/4	33-3/8	
	182	3	BP	10-1/4	44-9/16	49-1/16	10-11/16	9-7/16	1-1/4	33-3/8	
	182	3	27AC	10-1/4	49-3/16	53-11/16	10-11/16	9-7/16	1-1/4	33-3/8	
	182	3	CP	10-1/4	51-1/16	55-9/16	10-11/16	9-7/16	1-1/4	33-3/8	
	184	5	27AA	10-1/4	44-5/16	48-13/16	10-11/16	9-7/16	1-1/4	33-3/8	
	184	5	AP	10-1/4	40-7/8	45-5/8	10-11/16	9-7/16	1-1/4	33-3/8	
	184	5	27AB	10-1/4	48-3/16	52-11/16	10-11/16	9-7/16	1-1/4	33-3/8	
	184	5	BP	10-1/4	44-9/16	49-1/16	10-11/16	9-7/16	1-1/4	33-3/8	
	184	3	27AC	10-1/4	49-3/16	53-11/16	10-11/16	9-7/16	1-1/4	33-3/8	
	184	5	CP	10-1/4	51-1/16	55-9/16	10-11/16	9-7/16	1-1/4	33-3/8	
	213	7-1/2	27AB	10-1/4	48-3/16	52-11/16	10-11/16	4-1/8	6-9/16	35-1/16	
	213	7-1/2	BP	10-1/4	44-9/16	49-1/16	10-11/16	4-1/8	6-9/16	35-1/16	
	213	7-1/2	27AC	10-1/4	49-3/16	53-11/16	10-11/16	4-1/8	6-9/16	35-1/16	
	213	7-1/2	CP	10-1/4	51-1/16	55-9/16	10-11/16	4-1/8	6-9/16	35-1/16	
1-1/2 x 2 x 7 3500 R.P.M.	184	5	CP	10-1/4	50-15/16	55-7/16	11-1/16	9-3/8	1-11/16	33-13/16	4
	184	5	DP	10-1/4	53-5/8	58-1/8	11-1/16	9-3/8	1-11/16	33-13/16	
	213	7-1/2	27AC	10-1/4	49-7/16	53-15/16	11-1/16	4-1/16	7	35-1/2	
	213	7-1/2	CP	10-1/4	50-15/16	55-7/16	11-1/16	4-1/16	7	35-1/2	
	213	7-1/2	DP	10-1/4	53-5/8	58-1/8	11-1/16	4-1/16	7	35-1/2	
	215	10	27AC	10-1/4	49-7/16	53-15/16	11-1/16	3-5/16	7-3/4	37-1/2	
	215	10	CP	10-1/4	50-15/16	55-7/8	11-1/16	3-5/16	7-3/4	37-1/2	
	215	10	DP	10-1/4	53-5/8	58-1/8	11-1/16	3-5/16	7-3/4	37-1/2	
2 x 2-1/2 x 7A 3500 R.P.M.	184	5	EP	10-1/4	53-5/16	57-13/16	12	9-1/4	2-3/4	34-7/8	4
	213	7-1/2	EP	10-1/4	53-5/16	57-13/16	12	3-15/16	8-1/16	36-9/16	
	215	10	EP	10-1/4	53-5/16	57-13/16	12	3-3/16	8-13/16	38-9/16	
	254	15	DP	10-1/4	50-3/4	55-1/4	12	13/16	11-3/16	40-9/16	
	254	15	EP	10-1/4	53-5/16	57-13/16	12	13/16	11-3/16	40-9/16	
	256	20	EP	10-1/4	53-5/16	57-13/16	12	9/16†	12-9/16	44-9/16	
	213	7-1/2	EP	10-1/4	54-5/16	59-5/16	12-3/4	3-15/16	8-13/16	37-13/16	5
	215	10	EP	10-1/4	54-5/16	59-5/16	12-3/4	3-3/16	9-9/16	39-13/16	
	254	15	EP	10-1/4	54-5/16	59-5/16	12-3/4	13/16	11-15/16	41-13/16	
	256	20	EP	10-1/4	54-5/16	59-5/16	12-3/4	9/16†	13-5/16	45-13/16	
	213	7-1/2	EP	10-1/4	54-13/16	60-5/16	13-1/8	3-15/16	9-3/16	38-11/16	6
	215	10	EP	10-1/4	54-13/16	60-5/16	13-1/8	3-13/16	9-15/16	40-11/16	
	254	15	EP	10-1/4	54-13/16	60-5/16	13-1/8	13/16	12-5/16	42-11/16	
	256	20	EP	10-1/4	54-13/16	60-5/16	13-1/8	9/16†	13-11/16	46-11/16	

PRESSURE REDUCING VALVES									
DIRECT ACTING					PILOT OPERATED				
SIZE	1-1/2	2	2-1/2	4	2-1/2	3	1-1/4	1-1/2	4
CODE	27AA	27AB	27AC	CP	DP	EP	AP	BP	FP

TANK SIZE (GALLONS)	79	106	132	158	170	211
T	59	53	61	69	80	67
D	24	30	30	30	30	36

NOTES:

- ALL DIMENSIONS IN INCHES.
- DIMENSIONS MAY VARY ±1/2.
- NOT FOR CONSTRUCTION PURPOSES UNLESS CERTIFIED.
- DISCHARGE AND SUCTION FLANGES ANSI STANDARD FLAT FACE 125#.
- 1 GROUT HOLE IS PROVIDED IN TOP OF BASE.

†DISCHARGE CENTERLINE, "F" DIMENSION IS LEFT OF BASE FOR THESE PUMP SELECTIONS ONLY.

**PANEL HEIGHT 48" ON 208 VOLT 15 H.P. AND 20 H.P. ALSO 230 VOLT 20 H.P.

AURORA MODEL 762 PUMPS

AURORA - PC DUPLEX - WITH TANK 3500 R.P.M. PRESSURE CONTROL SYSTEMS

SECTION 750/760 PAGE 215

DATED JANUARY 1999

SUPERSEDES PAGE 215

DATED JUNE 1994

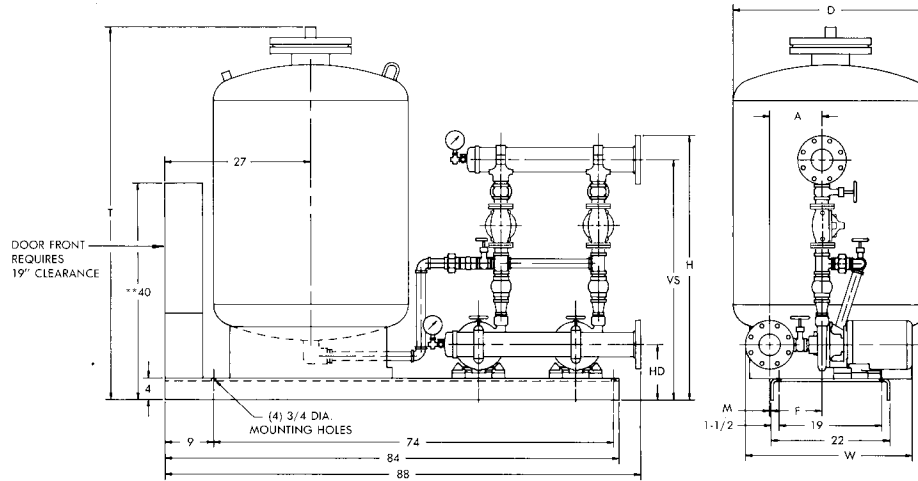

PUMP SIZE	MTR. FR.	H.P.	P R V	HD	VS	H	A	F	M	W	SUCTION & DISCHARGE MANIFOLDS
2-1/2 x 3 x 7B 3500 R.P.M.	254	15	EP	11-1/4	55-5/16	59-13/16	13-1/16	11/16	12-3/8	41-3/4	4
	254	15	EP	11-1/4	55-13/16	60-13/16	13-9/16	11/16	12-7/8	42-3/4	5
	256	20	EP	11-1/4	55-13/16	60-13/16	13-9/16	11/16†	14-1/4	46-3/4	6
	215	10	FP	11-1/4	66-1/16	71-9/16	14-1/16	3-1/16	11	41-3/4	
	254	15	FP	11-1/4	66-1/16	71-9/16	14-1/16	11/16	13-3/8	43-3/4	
	256	20	FP	11-1/4	66-1/16	71-9/16	14-1/16	11/16†	14-3/4	47-3/4	
	254	15	EP	11-1/4	56-5/16	61-13/16	14-1/16	11/16	13-3/8	43-3/4	
256	20	EP	11-1/4	56-5/16	61-13/16	14-1/16	11/16†	14-3/4	47-3/4		
1-1/2 x 2 x 9C 3500 R.P.M.	213	7-1/2	27AB	11-1/4	50-13/16	55-5/16	11-3/16	4-1/16	7-1/8	35-5/8	4
	213	7-1/2	BP	11-1/4	44	48-1/2	11-3/16	4-1/16	7-1/8	35-5/8	
	215	10	27AB	11-1/4	50-13/16	55-5/16	11-3/16	3-5/16	7-7/8	37-5/8	
	215	10	27AC	11-1/4	51-13/16	56-5/16	11-3/16	3-5/16	7-7/8	37-5/8	
	215	10	CP	11-1/4	53-5/16	57-13/16	11-3/16	3-5/16	7-7/8	37-5/8	
	215	10	BP	11-1/4	44	48-1/2	11-3/16	3-5/16	7-7/8	37-5/8	
	254	15	27AB	11-1/4	50-13/16	55-5/16	11-3/16	15/16	10-1/4	39-5/8	
	254	15	27AC	11-1/4	51-13/16	56-5/16	11-3/16	15/16	10-1/4	39-5/8	
	254	15	CP	11-1/4	53-5/16	57-13/16	11-3/16	15/16	10-1/4	39-5/8	
	254	15	DP	11-1/4	56	60-1/2	11-3/16	15/16	10-1/4	39-5/8	
	254	15	BP	11-1/4	44	48-1/2	11-3/16	15/16	10-1/4	39-5/8	
	256	20	27AC	11-1/4	51-13/16	56-5/16	11-3/16	7/16†	11-5/8	43-5/8	
	256	20	CP	11-1/4	53-5/16	57-13/16	11-3/16	7/16†	11-5/8	43-5/8	
	256	20	DP	11-1/4	56	60-1/2	11-3/16	7/16†	11-5/8	43-5/8	
2 x 2-1/2 x 9 3500 R.P.M.	254	15	EP	11-3/4	56-11/16	61-3/16	12	13/16	11-3/16	40-9/16	4
	256	20	EP	11-3/4	56-11/16	61-3/16	12	9/16†	12-9/16	44-9/16	5
	254	15	EP	11-3/4	57-3/16	62-3/16	12-3/4	13/16	11-15/16	41-13/16	
	256	20	EP	11-3/4	57-3/16	62-3/16	12-3/4	9/16†	13-5/16	45-13/16	6
	254	15	EP	11-3/4	57-11/16	63-3/16	13-1/8	13/16	12-5/16	42-11/16	
	256	20	EP	11-3/4	57-11/16	63-3/16	13-1/8	9/16†	13-11/16	46-11/16	

PRESSURE REDUCING VALVES									
DIRECT ACTING					PILOT OPERATED				
SIZE	1-1/2	2	2-1/2	2	2-1/2	3	1-1/4	1-1/2	4
CODE	27AA	27AB	27AC	CP	DP	EP	AP	BP	FP

TANK SIZE (GALLONS)	79	106	132	158	170	211
T	59	53	61	69	80	70
D	24	30	30	30	30	36

- NOTES:
- ALL DIMENSIONS IN INCHES.
 - DIMENSIONS MAY VARY ±1/2.
 - NOT FOR CONSTRUCTION PURPOSES UNLESS CERTIFIED.
 - DISCHARGE AND SUCTION FLANGES ANSI STANDARD FLAT FACE 125#.
 - 1 GROUT HOLE IS PROVIDED IN TOP OF BASE.

†DISCHARGE CENTERLINE, "F" DIMENSION IS LEFT OF BASE FOR THESE PUMP SELECTIONS ONLY.

**PANEL HEIGHT 48" ON 208 VOLT 15 H.P. AND 20 H.P. ALSO 230 VOLT 20 H.P.

**AURORA - PC
 DUPLEX - WITH TANK**

1750 R.P.M.

PRESSURE CONTROL SYSTEMS

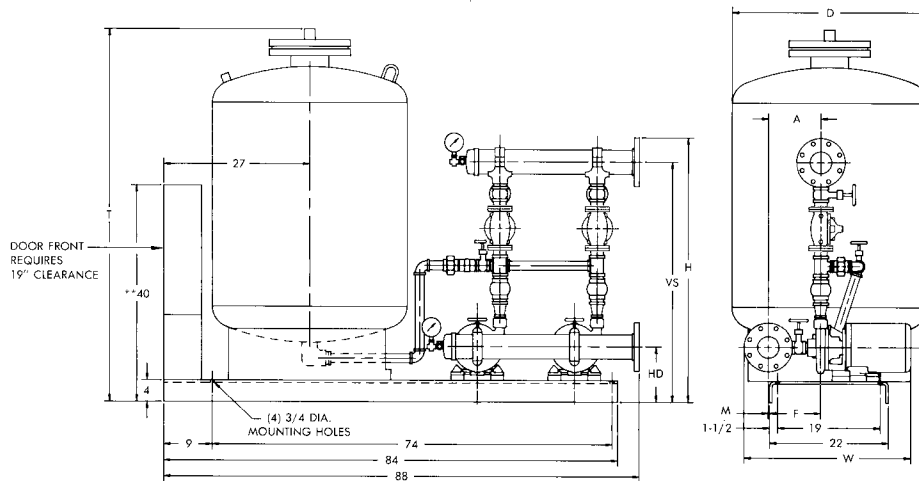

PUMP SIZE	MTR. FR.	H.P.	P R V	HD	VS	H	A	F	M	W	SUCTION & DISCHARGE MANIFOLDS
1-1/2 x 2 x 9C 1750 R.P.M.	143	1	27AA	11-1/4	43-7/8	48-3/8	11-3/16	10-3/16	1	32-7/8	4
	143	1	27AB	11-1/4	50-13/16	55-5/16	11-3/16	10-3/16	1	32-7/8	
	143	1	AP	11-1/4	46-7/16	50-15/16	11-3/16	10-3/16	1	32-7/8	
	143	1	BP	11-1/4	44	48-1/8	11-3/16	10-3/16	1	32-7/8	
	145	1-1/2	27AA	11-1/4	43-7/8	48-3/8	11-3/16	10-3/16	1	33-7/8	
	145	1-1/2	27AB	11-1/4	50-13/16	55-5/16	11-3/16	10-3/16	1	33-7/8	
	145	1-1/2	AP	11-1/4	46-7/16	50-15/16	11-3/16	10-3/16	1	33-7/8	
	145	1-1/2	BP	11-1/4	44	48-1/2	11-3/16	10-3/16	1	33-7/8	
	145	2	27AA	11-1/4	43-7/8	48-3/8	11-3/16	10-3/16	1	33-7/8	
	145	2	27AB	11-1/4	50-13/16	55-5/16	11-3/16	10-3/16	1	33-7/8	
	145	2	27AC	11-1/4	51-13/16	56-5/16	11-3/16	10-3/16	1	33-7/8	
	145	2	CP	11-1/4	53-5/16	57-13/16	11-3/16	10-3/16	1	33-7/8	
	145	2	AP	11-1/4	46-7/16	50-15/16	11-3/16	10-3/16	1	33-7/8	
	145	2	BP	11-1/4	44	48-1/2	11-3/16	10-3/16	1	33-7/8	
	182	3	27AA	11-1/4	43-7/8	48-3/8	11-3/16	10-3/16	1	33-7/8	
	182	3	27AB	11-1/4	50-13/16	55-5/16	11-3/16	10-3/16	1	33-7/8	
	182	3	27AC	11-1/4	51-13/16	56-5/16	11-3/16	10-3/16	1	33-7/8	
	182	3	CP	11-1/4	53-5/16	57-13/16	11-3/16	10-3/16	1	33-7/8	
	182	3	AP	11-1/4	46-7/16	50-15/16	11-3/16	10-3/16	1	33-7/8	
	182	3	BP	11-1/4	44	48-1/2	11-3/16	10-3/16	1	33-7/8	
2 x 2-1/2 x 9 1750 R.P.M.	145	2	27AC	11-3/4	53-5/16	57-13/16	12	9-5/16	2-11/16	34-13/16	4
	145	2	CP	11-3/4	48-7/8	53-3/8	12	9-5/16	2-11/16	34-13/16	
	145	2	DP	11-3/4	53-5/8	58-1/8	12	9-5/16	2-11/16	34-13/16	
	182	3	27AB	11-3/4	48-7/8	53-3/8	12	9-5/16	2-11/16	34-13/16	
	182	3	27AC	11-3/4	53-5/16	57-13/16	12	9-5/16	2-11/16	34-13/16	
	182	3	CP	11-3/4	48-7/8	53-3/8	12	9-5/16	2-11/16	34-13/16	
	182	3	DP	11-3/4	53-5/8	58-1/8	12	9-5/16	2-11/16	34-13/16	
	182	3	BP	11-3/4	48-5/16	52-13/16	12	9-5/16	2-11/16	34-13/16	
	184	5	27AC	11-3/4	53-5/16	57-13/16	12	9-5/16	2-11/16	34-13/16	
	184	5	CP	11-3/4	48-7/8	53-3/8	12	9-5/16	2-11/16	34-13/16	
184	5	DP	11-3/4	53-5/8	58-1/8	12	9-5/16	2-11/16	34-13/16		

PRESSURE REDUCING VALVES									
DIRECT ACTING					PILOT OPERATED				
SIZE	1-1/2	2	2-1/2	2	2-1/2	3	1-1/4	1-1/2	4
CODE	27AA	27AB	27AC	CP	DP	EP	AP	BP	FP

TANK SIZE (GALLONS)	79	106	132	158	170	211
T	59	53	61	69	80	67
D	24	30	30	30	30	36

NOTES:

1. ALL DIMENSIONS IN INCHES.
2. DIMENSIONS MAY VARY ±1/2.
3. NOT FOR CONSTRUCTION PURPOSES UNLESS CERTIFIED.
4. DISCHARGE AND SUCTION FLANGES ANSI STANDARD FLAT FACE 125#.
5. 1 GROUT HOLE IS PROVIDED IN TOP OF BASE.

**PANEL HEIGHT 48" ON 208 VOLT 15 H.P. AND 20 H.P.
 ALSO 230 VOLT 20 H.P.

AURORA MODEL 762 PUMPS

AURORA - PC DUPLEX - WITH TANK 1750 R.P.M. PRESSURE CONTROL SYSTEMS

SECTION 750/760 PAGE 217

DATED JANUARY 1999

SUPERSEDES PAGE 217

DATED JUNE 1994

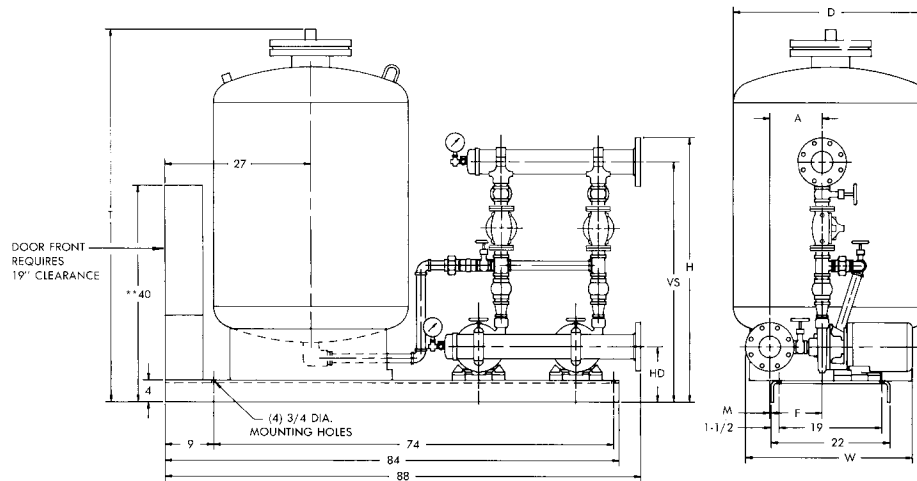

PUMP SIZE	MTR. FR.	H.P.	P R V	HD	VS	H	A	F	M	W	SUCTION & DISCHARGE MANIFOLDS		
2-1/2 x 3 x 9 1750 R.P.M.	182	3	27AC	11-3/4	49-9/16	54-1/16	13-1/16	9-3/16	3-7/8	36	4		
	182	3	CP	11-3/4	52-1/8	56-5/8	13-1/16	9-3/16	3-7/8	36			
	182	3	DP	11-3/4	50-7/8	55-3/8	13-1/16	9-3/16	3-7/8	36			
	182	3	EP	11-3/4	57-3/16	61-11/16	13-1/16	9-3/16	3-7/8	36			
	184	5	27AC	11-3/4	49-9/16	54-1/16	13-1/16	9-3/16	3-7/8	36			
	184	5	CP	11-3/4	52-1/8	56-5/8	13-1/16	9-3/16	3-7/8	36			
	184	5	DP	11-3/4	50-7/8	55-3/8	13-1/16	9-3/16	3-7/8	36			
	184	5	EP	11-3/4	57-3/16	61-11/16	13-1/16	9-3/16	3-7/8	36			
	213	7-1/2	EP	11-3/4	57-3/16	61-11/16	13-1/16	3-13/16	9-1/4	37-3/4			
	182	3	DP	11-3/4	51-5/8	56-5/8	13-9/16	9-3/16	3-7/8	36-1/2		5	
	182	3	EP	11-3/4	57-11/16	62-11/16	13-9/16	9-3/16	3-7/8	36-1/2			
	184	5	DP	11-3/4	51-5/8	56-5/8	13-9/16	9-3/16	3-7/8	36-1/2			
	184	5	EP	11-3/4	57-11/16	62-11/16	13-9/16	9-3/16	3-7/8	36-1/2			
	2 x 3 x 11 1750 R.P.M.	213	7-1/2	EP	11-3/4	57-11/16	62-11/16	13-9/16	3-13/16	9-3/4		38-1/4	6
184		5	EP	11-3/4	58-3/16	63-11/16	14-1/16	9-3/16	3-7/8	37			
213		7-1/2	EP	11-3/4	58-3/16	63-11/16	14-1/16	3-13/16	10-1/4	38-3/4			
213		7-1/2	27AC	12-1/4	54-13/16	59-5/16	13-7/16	3-7/8	9-9/16	38-1/16	4		
213		7-1/2	CP	12-1/4	50-3/8	54-7/8	13-7/16	3-7/8	9-9/16	38-1/16			
213		7-1/2	DP	12-1/4	55-1/8	59-5/8	13-7/16	3-7/8	9-9/16	38-1/16			
215		10	DP	12-1/4	55-1/8	59-5/8	13-7/16	3-1/8	10-5/16	40-1/16			
1-1/2 x 2 x 12 1750 R.P.M.		213	7-1/2	EP	12-1/4	58-3/16	62-11/16	13-7/16	3-7/8	9-9/16	38-1/16	5	
		215	10	EP	12-1/4	58-3/16	62-11/16	13-7/16	3-1/8	10-5/16	40-1/16		
		213	7-1/2	EP	12-1/4	58-11/16	63-11/16	13-15/16	3-7/8	10-1/16	38-1/16		
	215	10	EP	12-1/4	58-11/16	63-11/16	13-15/16	3-1/8	10-13/16	40-1/16			
	213	7-1/2	EP	12-1/4	59-3/16	64-11/16	14-7/16	3-7/8	10-9/16	38-1/16	6		
	215	10	EP	12-1/4	59-3/16	64-11/16	14-7/16	3-1/8	11-5/16	40-1/16			
	213	7-1/2	27AA	13	46-5/8	51-1/8	11-5/16	3-15/16	7-3/8	35-7/8			4
	213	7-1/2	AP	13	49-3/16	53-11/16	11-5/16	3-15/16	7-3/8	35-7/8			
213	7-1/2	27AB	13	53-9/16	58-1/8	11-5/16	3-15/16	7-3/8	35-7/8				
213	7-1/2	BP	13	46-3/4	51-1/4	11-5/16	3-15/16	7-3/8	35-7/8				
213	7-1/2	27AC	13	54-5/16	58-13/16	11-5/16	3-15/16	7-3/8	35-7/8				
213	7-1/2	CP	13	56-7/16	60-15/16	11-5/16	3-15/16	7-3/8	35-7/8				
213	7-1/2	DP	13	58-3/4	63-1/4	11-5/16	3-15/16	7-3/8	35-7/8				
215	10	27AC	13	54-5/16	58-13/16	11-5/16	3-3/16	8-1/8	37-7/8				
215	10	CP	13	56-7/8	60-15/16	11-5/16	3-3/16	8-1/8	37-7/8				
215	10	DP	13	58-3/4	63-1/4	11-5/16	3-3/16	8-1/8	37-7/8				

- NOTES:
1. ALL DIMENSIONS IN INCHES.
 2. DIMENSIONS MAY VARY ±1/2.
 3. NOT FOR CONSTRUCTION PURPOSES UNLESS CERTIFIED.
 4. DISCHARGE AND SUCTION FLANGES ANSI STANDARD FLAT FACE 125#.
 5. 1 GROUT HOLE IS PROVIDED IN TOP OF BASE.

PRESSURE REDUCING VALVES									
DIRECT ACTING					PILOT OPERATED				
SIZE	1-1/2	2	2-1/2	2	2-1/2	3	1-1/4	1-1/2	4
CODE	27AA	27AB	27AC	CP	DP	EP	AP	BP	FP

TANK SIZE (GALLONS)	79	106	132	158	170	211
T	59	53	61	69	80	67
D	24	30	30	30	30	36

PRESSURE CONTROL SYSTEMS

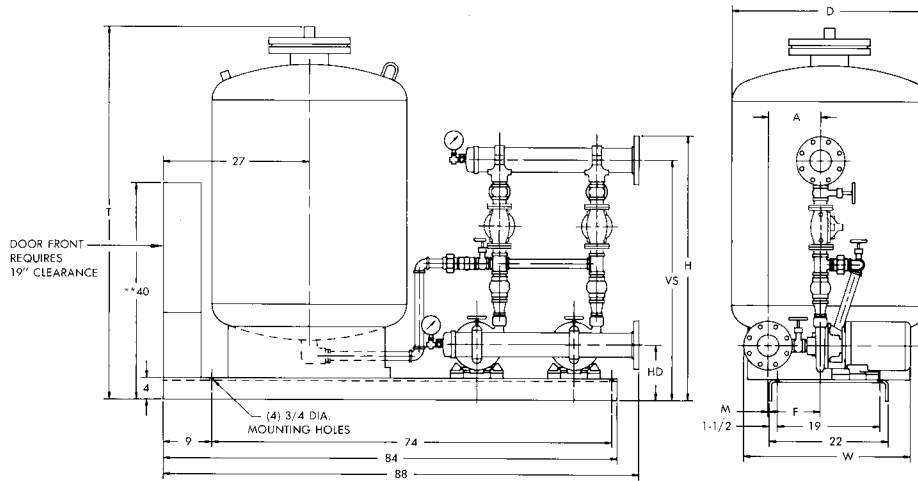

PUMP SIZE	MTR. FR.	H.P.	P R V	HD	VS	H	A	F	M	W	SUCTION & DISCHARGE MANIFOLDS
2-1/2 x 3 x 12 1750 R.P.M.	254	15	DP	13-1/4	53-3/8	57-7/8	13-1/16	9/16	12-1/2	41-7/8	4
	213	7-1/2	EP	13-1/4	59-11/16	64-3/16	13-1/16	3-11/16	9-3/8	37-7/8	
	215	10	EP	13-1/4	59-11/16	64-3/16	13-1/16	2-15/16	10-1/8	39-7/8	
	254	15	EP	13-1/4	59-11/16	64-3/16	13-1/16	9/16	12-1/2	41-7/8	
	213	7-1/2	EP	13-1/4	60-3/16	65-3/16	13-9/16	3-11/16	9-7/8	38-7/8	5
	215	10	EP	13-1/4	60-3/16	65-3/16	13-9/16	2-15/16	10-5/8	40-7/8	
	254	15	EP	13-1/4	60-3/16	65-3/16	13-9/16	9/16	13	42-7/8	
	256	20	EP	13-1/4	60-3/16	65-3/16	13-9/16	13/16†	14-3/8	46-7/8	
	215	10	EP	13-1/4	60-11/16	66-3/16	14-1/16	2-15/16	11-1/8	41-7/8	6
	254	15	EP	13-1/4	60-11/16	66-3/16	14-1/16	9/16	13-1/2	43-7/8	
	256	20	EP	13-1/4	60-11/16	66-3/16	14-1/16	13/16†	14-7/8	47-7/8	
	254	15	FP	13-1/4	70-7/16	75-15/16	14-1/16	9/16	13-1/2	43-7/8	
256	20	FP	13-1/4	70-7/16	75-15/16	14-1/16	13/16†	14-7/8	47-7/8		

NOTES:

1. ALL DIMENSIONS IN INCHES.
2. DIMENSIONS MAY VARY ±1/2.
3. NOT FOR CONSTRUCTION PURPOSES UNLESS CERTIFIED.
4. DISCHARGE AND SUCTION FLANGES ANSI STANDARD FLAT FACE 125#.
5. 1 GROUT HOLE IS PROVIDED IN TOP OF BASE.

†DISCHARGE CENTERLINE, "F" DIMENSION IS LEFT OF BASE FOR THESE PUMP SELECTIONS ONLY.

**PANEL HEIGHT 48" ON 208 VOLT 15 H.P. AND 20 H.P. ALSO 230 VOLT 20 H.P.

PRESSURE REDUCING VALVES									
DIRECT ACTING				PILOT OPERATED					
SIZE	1-1/2	2	2-1/2	2	2-1/2	3	1-1/4	1-1/2	4
CODE	27AA	27AB	27AC	CP	DP	EP	AP	BP	FP

TANK SIZE (GALLONS)	79	106	132	158	170	211
T	59	53	61	69	80	67
D	24	30	30	30	30	36

AURORA MODEL 763 PUMPS

AURORA - PC

TRIPLEX - 3500 R.P.M.

PRESSURE CONTROL SYSTEMS

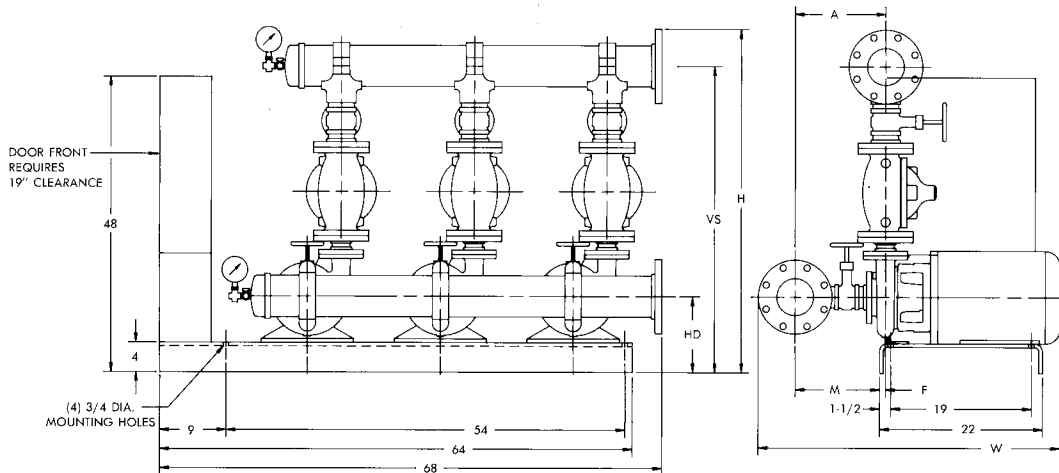

PUMP SIZE	MTR. FR.	H.P.	P R V	HD	VS	H	A	F	M	W	SUCTION & DISCHARGE MANIFOLDS
1-1/4 x 1-1/2 x 7 3500 R.P.M.	145	2	27AA	10-1/4	34-5/16	38-13/16	10-11/16	9-7/16	1-1/4	33-3/8	4
	145	2	AP	10-1/4	31-3/8	35-7/8	10-11/16	9-7/16	1-1/4	33-3/8	
	182	3	27AA	10-1/4	34-5/16	38-13/16	10-11/16	9-7/16	1-1/4	33-3/8	
	182	3	AP	10-1/4	31-3/8	35-7/8	10-11/16	9-7/16	1-1/4	33-3/8	
	182	3	27AB	10-1/4	37	41-1/2	10-11/16	9-7/16	1-1/4	33-3/8	
	182	3	BP	10-1/4	34-9/16	39-1/16	10-11/16	9-7/16	1-1/4	33-3/8	
	182	3	27AC	10-1/4	38-7/16	42-15/16	10-11/16	9-7/16	1-1/4	33-3/8	
	182	3	CP	10-1/4	39-7/8	44-3/8	10-11/16	9-7/16	1-1/4	33-3/8	
	184	5	27AA	10-1/4	34-5/16	38-13/16	10-11/16	9-7/16	1-1/4	33-3/8	
	184	5	AP	10-1/4	31-3/8	35-7/8	10-11/16	9-7/16	1-1/4	33-3/8	
	184	5	27AB	10-1/4	37	41-1/2	10-11/16	9-7/16	1-1/4	33-3/8	
	184	5	BP	10-1/4	34-9/16	39-1/16	10-11/16	9-7/16	1-1/4	33-3/8	
	184	5	27AC	10-1/4	38-7/16	42-15/16	10-11/16	9-7/16	1-1/4	33-3/8	
	184	5	CP	10-1/4	39-7/8	44-3/8	10-11/16	9-7/16	1-1/4	33-3/8	
	213	7-1/2	27AB	10-1/4	37	41-1/2	10-11/16	4-1/8	6-9/16	35-1/16	
	213	7-1/2	BP	10-1/4	34-9/16	39-1/16	10-11/16	4-1/8	6-9/16	35-1/16	
	213	7-1/2	27AC	10-1/4	38-7/16	42-15/16	10-11/16	4-1/8	6-9/16	35-1/16	
	213	7-1/2	CP	10-1/4	39-7/8	44-3/8	10-11/16	4-1/8	6-9/16	35-1/16	
1-1/2 x 2 x 7 3500 R.P.M.	184	5	CP	10-1/4	39-3/4	44-1/4	11-1/16	9-3/8	1-11/16	33-13/16	4
	184	5	DP	10-1/4	42-7/8	47-3/8	11-1/16	9-3/8	1-11/16	33-13/16	
	213	7-1/2	27AC	10-1/4	38-11/16	43-3/16	11-1/16	4-1/16	7	35-1/2	
	213	7-1/2	CP	10-1/4	39-3/4	44-1/4	11-1/16	4-1/16	7	35-1/2	
	213	7-1/2	DP	10-1/4	42-7/8	47-3/8	11-1/16	4-1/16	7	35-1/2	
	215	10	27AC	10-1/4	38-11/16	43-3/16	11-1/16	3-5/16	7-3/4	37-1/2	
	215	10	CP	10-1/4	39-3/4	44-1/4	11-1/16	3-5/16	7-3/4	37-1/2	
	215	10	DP	10-1/4	42-7/8	47-3/8	11-1/16	3-5/16	7-3/4	37-1/2	
2 x 2-1/2 x 7A 3500 R.P.M.	184	5	EP	10-1/4	41-13/16	46-5/16	12	9-1/4	2-3/4	34-7/8	4
	213	7-1/2	EP	10-1/4	41-13/16	46-5/16	12	3-15/16	8-1/16	36-9/16	
	215	10	EP	10-1/4	41-13/16	46-5/16	12	3-3/16	8-13/16	38-9/16	
	254	15	DP	10-1/4	40	44-1/2	12	13/16	11-3/16	40-9/16	
	254	15	EP	10-1/4	41-13/16	46-5/16	12	13/16	11-3/16	40-9/16	
	256	20	EP	10-1/4	41-13/16	46-5/16	12	9/16†	12-9/16	44-9/16	
	213	7-1/2	EP	10-1/4	42-13/16	47-13/16	12-3/4	3-15/16	8-13/16	37-13/16	
	215	10	EP	10-1/4	42-13/16	47-13/16	12-3/4	3-3/16	9-9/16	39-13/16	
	254	15	EP	10-1/4	42-13/16	47-13/16	12-3/4	13/16	11-15/16	41-13/16	
	256	20	EP	10-1/4	42-13/16	47-13/16	12-3/4	9/16†	13-5/16	45-13/16	
	213	7-1/2	EP	10-1/4	43-5/16	48-13/16	13-1/8	3-15/16	9-3/16	38-11/16	
	215	10	EP	10-1/4	43-5/16	48-13/16	13-1/8	3-3/16	9-15/16	40-11/16	
	254	15	EP	10-1/4	43-5/16	48-13/16	13-1/8	13/16	12-5/16	42-11/16	
	256	20	EP	10-1/4	43-5/16	48-13/16	13-1/8	9/16†	13-11/16	46-11/16	

- NOTES:
- ALL DIMENSIONS IN INCHES.
 - DIMENSIONS MAY VARY ± 1/2.
 - NOT FOR CONSTRUCTION PURPOSES UNLESS CERTIFIED.
 - DISCHARGE AND SUCTION FLANGES AMERICAN STANDARD FLAT FACE 125#.
 - 1 GROUT HOLE IS PROVIDED IN TOP OF BASE.

PRESSURE REDUCING VALVES									
DIRECT ACTING					PILOT OPERATED				
SIZE	1-1/2	2	2-1/2	2	2-1/2	3	1-1/4	1-1/2	4
CODE	27AA	27AB	27AC	CP	DP	EP	AP	BP	FP

†DISCHARGE CENTERLINE, "F" DIMENSION IS LEFT OF BASE FOR THESE PUMP SELECTIONS ONLY.

AURORA MODEL 763 PUMPS

AURORA - PC

TRIPLEX - 3500 R.P.M.

PRESSURE CONTROL SYSTEMS

SUPERSEDES PAGE 220
 DATED AUGUST 1987

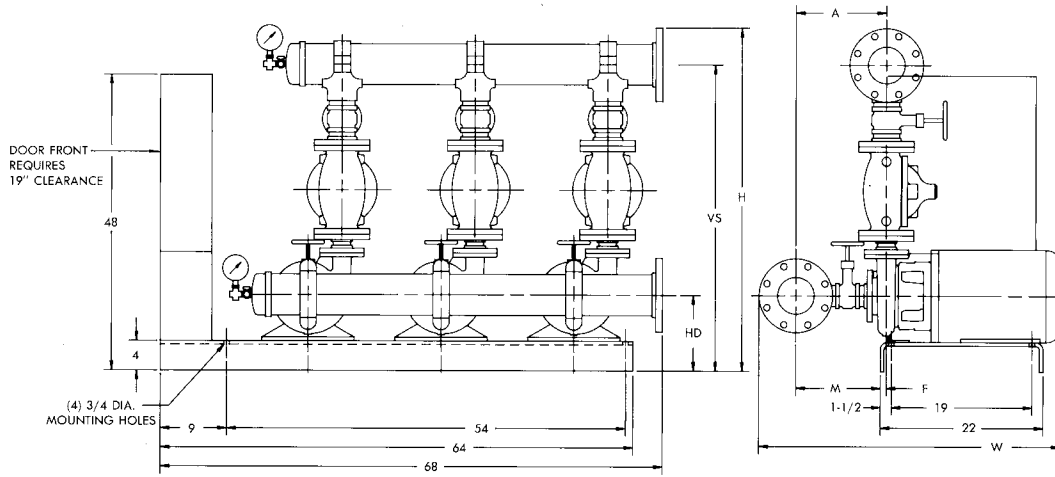

PUMP SIZE	MTR. FR.	H.P.	P R V	HD	VS	H	A	F	M	W	SUCTION & DISCHARGE MANIFOLDS
2-1/2 x 3 x 7B 3500 R.P.M.	254	15	EP	11-1/4	43-13/16	48-5/16	13-1/16	11/16	12-3/8	41-3/4	4
	254	15	EP	11-1/4	44-5/16	49-5/16	13-9/16	11/16	12-7/8	42-3/4	5
	256	20	EP	11-1/4	44-5/16	49-5/16	13-9/16	11/16†	14-1/4	46-3/4	6
	215	10	FP	11-1/4	52-5/16	57-13/16	14-1/16	3-1/16	11	41-3/4	
	254	15	FP	11-1/4	52-5/16	57-13/16	14-1/16	11/16	13-3/8	43-3/4	
	256	20	FP	11-1/4	52-5/16	57-13/16	14-1/16	11/16†	14-3/4	47-3/4	
	254	15	EP	11-1/4	44-13/16	50-5/16	14-1/16	11/16	13-3/8	43-3/4	
256	20	EP	11-1/4	44-13/16	50-5/16	14-1/16	11/16†	14-3/4	47-3/4		
1-1/2 x 2 x 9C 3500 R.P.M.	213	7-1/2	27AB	11-1/4	39-5/8	44-1/8	11-3/16	4-1/16	7-1/8	35-5/8	4
	213	7-1/2	BP	11-1/4	34	38-1/2	11-3/16	4-1/16	7-1/8	35-5/8	
	215	10	27AB	11-1/4	39-5/8	44-1/8	11-3/16	3-5/16	7-7/8	37-5/8	
	215	10	27AC	11-1/4	41-1/16	45-9/16	11-3/16	3-5/16	7-7/8	37-5/8	
	215	10	CP	11-1/4	42-1/8	46-5/8	11-3/16	3-5/16	7-7/8	37-5/8	
	215	10	BP	11-1/4	34	38-1/2	11-3/16	3-5/16	7-7/8	37-5/8	
	254	15	27AB	11-1/4	39-5/8	44-1/8	11-3/16	15/16	10-1/4	39-5/8	
	254	15	27AC	11-1/4	41-1/16	45-9/16	11-3/16	15/16	10-1/4	39-5/8	
	254	15	CP	11-1/4	42-1/8	46-5/8	11-3/16	15/16	10-1/4	39-5/8	
	254	15	DP	11-1/4	45-1/4	49-3/4	11-3/16	15/16	10-1/4	39-5/8	
	254	15	BP	11-1/4	34	38-1/2	11-3/16	15/16	10-1/4	39-5/8	
	256	20	27AC	11-1/4	41-1/16	45-9/16	11-3/16	7/16†	11-5/8	43-5/8	
	256	20	CP	11-1/4	42-1/8	46-5/8	11-3/16	7/16†	11-5/8	43-5/8	
	256	20	DP	11-1/4	45-1/4	49-3/4	11-3/16	7/16†	11-5/8	43-5/8	
	2 x 2-1/2 x 9 3500 R.P.M.	254	15	EP	11-3/4	45-3/16	49-11/16	12	13/16	11-3/16	
256		20	EP	11-3/4	45-3/16	49-11/16	12	9/16†	12-9/16	44-9/16	5
254		15	EP	11-3/4	45-11/16	50-11/16	12-3/4	13/16	11-15/16	41-13/16	
256		20	EP	11-3/4	45-11/16	50-11/16	12-3/4	9/16†	13-5/16	45-13/16	6
254		15	EP	11-3/4	46-3/16	51-11/16	13-1/8	13/16	12-5/16	42-11/16	
256	20	EP	11-3/4	46-3/16	51-11/16	13-1/8	9/16†	13-11/16	46-11/16		

NOTES:

- ALL DIMENSIONS IN INCHES.
- DIMENSIONS MAY VARY ± 1/2.
- NOT FOR CONSTRUCTION PURPOSES UNLESS CERTIFIED.
- DISCHARGE AND SUCTION FLANGES AMERICAN STANDARD FLAT FACE 125#.
- 1 GROUT HOLE IS PROVIDED IN TOP OF BASE.

PRESSURE REDUCING VALVES										
DIRECT ACTING					PILOT OPERATED					
SIZE	1-1/2	2	2-1/2	3	2	2-1/2	3	1-1/4	1-1/2	4
CODE	27AA	27AB	27AC	CP	DP	EP	AP	BP	FP	

†DISCHARGE CENTERLINE, "F" DIMENSION IS LEFT OF BASE FOR THESE PUMP SELECTIONS ONLY.

AURORA MODEL 763 PUMPS

AURORA - PC

TRIPLEX - 1750 R.P.M.

PRESSURE CONTROL SYSTEMS

SECTION 750/760 PAGE 221

DATED JULY 1999

SUPERSEDES PAGE 221

DATED AUGUST 1987

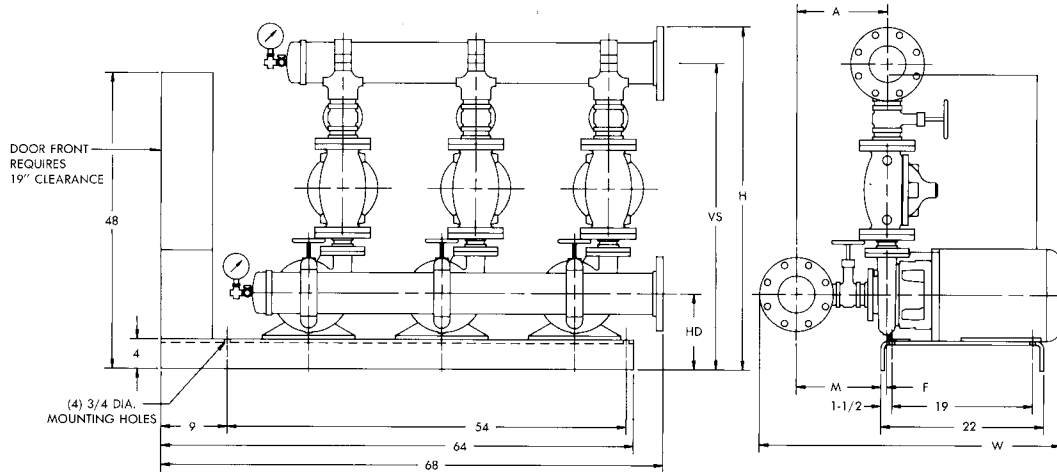

PUMP SIZE	MTR. FR.	H.P.	P R V	HD	VS	H	A	F	M	W	SUCTION & DISCHARGE MANIFOLDS
1-1/2 x 2 x 9C 1750 R.P.M.	143	1	27AA	11-1/4	33-7/8	38-3/8	11-3/16	10-3/16	1	32-7/8	4
	143	1	27AB	11-1/4	39-5/8	44-1/8	11-3/16	10-3/16	1	32-7/8	
	143	1	AP	11-1/4	36-15/16	41-1/16	11-3/16	10-3/16	1	32-7/8	
	143	1	BP	11-1/4	34	38-1/2	11-3/16	10-3/16	1	32-7/8	
	145	1-1/2	27AA	11-1/4	33-7/8	38-3/8	11-3/16	10-3/16	1	33-7/8	
	145	1-1/2	27AB	11-1/4	39-5/8	44-1/8	11-3/16	10-3/16	1	33-7/8	
	145	1-1/2	AP	11-1/4	36-15/16	41-1/16	11-3/16	10-3/16	1	33-7/8	
	145	1-1/2	BP	11-1/4	34	38-1/2	11-3/16	10-3/16	1	33-7/8	
	145	2	27AA	11-1/4	33-7/8	38-3/8	11-3/16	10-3/16	1	33-7/8	
	145	2	27AB	11-1/4	39-5/8	44-1/8	11-3/16	10-3/16	1	33-7/8	
	145	2	27AC	11-1/4	41-1/16	45-9/16	11-3/16	10-3/16	1	33-7/8	
	145	2	CP	11-1/4	42-1/8	46-5/8	11-3/16	10-3/16	1	33-7/8	
	145	2	AP	11-1/4	36-15/16	41-7/16	11-3/16	10-3/16	1	33-7/8	
	145	2	BP	11-1/4	34	38-1/2	11-3/16	10-3/16	1	33-7/8	
	182	3	27AA	11-1/4	33-7/8	38-3/8	11-3/16	10-3/16	1	33-7/8	
	182	3	27AB	11-1/4	39-5/8	44-1/8	11-3/16	10-3/16	1	33-7/8	
	182	3	27AC	11-1/4	41-1/16	45-9/16	11-3/16	10-3/16	1	33-7/8	
	182	3	CP	11-1/4	42-1/8	46-5/8	11-3/16	10-3/16	1	33-7/8	
	182	3	AP	11-1/4	36-15/16	41-7/16	11-3/16	10-3/16	1	33-7/8	
	182	3	BP	11-1/4	34	38-1/2	11-3/16	10-3/16	1	33-7/8	
2 x 2-1/2 x 9 1750 R.P.M.	145	2	27AC	11-3/4	42-9/16	47-1/16	12	9-5/16	2-11/16	34-13/16	4
	145	2	CP	11-3/4	37-11/16	42-3/16	12	9-5/16	2-11/16	34-13/16	
	145	2	DP	11-3/4	42-7/8	47-3/8	12	9-5/16	2-11/16	34-13/16	
	182	3	27AB	11-3/4	37-11/16	42-3/16	12	9-5/16	2-11/16	34-13/16	
	182	3	27AC	11-3/4	42-9/16	47-1/16	12	9-5/16	2-11/16	34-13/16	
	182	3	CP	11-3/4	37-11/16	42-3/16	12	9-5/16	2-11/16	34-13/16	
	182	3	DP	11-3/4	42-7/8	47-3/8	12	9-5/16	2-11/16	34-13/16	
	182	3	BP	11-3/4	38-5/16	42-13/16	12	9-5/16	2-11/16	34-13/16	
	184	5	27AC	11-3/4	42-9/16	47-1/16	12	9-5/16	2-11/16	34-13/16	
	184	5	CP	11-3/4	37-11/16	42-3/16	12	9-5/16	2-11/16	34-13/16	
184	5	DP	11-3/4	42-7/8	47-3/8	12	9-5/16	2-11/16	34-13/16		

NOTES:

- ALL DIMENSIONS IN INCHES.
- DIMENSIONS MAY VARY ± 1/2.
- NOT FOR CONSTRUCTION PURPOSES UNLESS CERTIFIED.
- DISCHARGE AND SUCTION FLANGES AMERICAN STANDARD FLAT FACE 125#.
- 1 GROUT HOLE IS PROVIDED IN TOP OF BASE.

PRESSURE REDUCING VALVES									
DIRECT ACTING					PILOT OPERATED				
SIZE	1-1/2	2	2-1/2	3	2-1/2	3	1-1/4	1-1/2	4
CODE	27AA	27AB	27AC	CP	DP	EP	AP	BP	FP

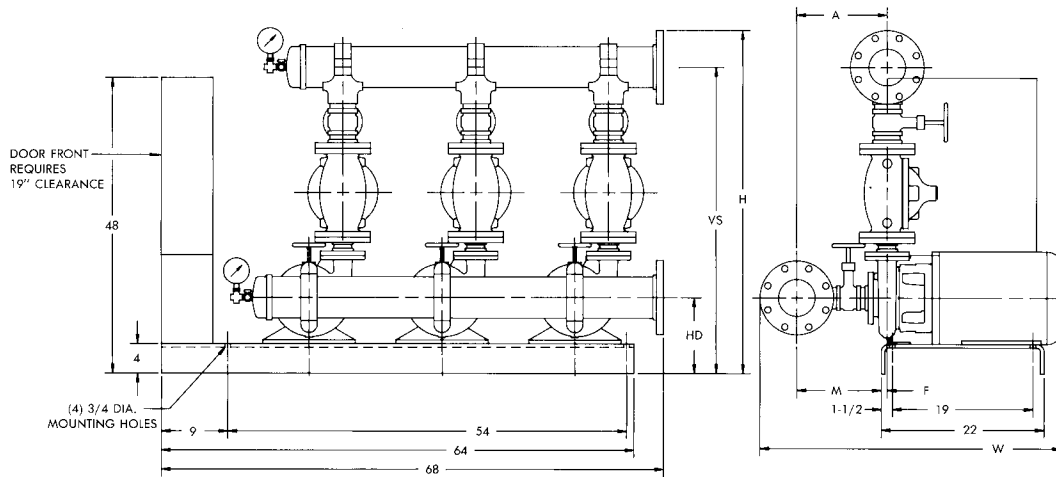

PUMP SIZE	MTR. FR.	H.P.	P R V	HD	VS	H	A	F	M	W	SUCTION & DISCHARGE MANIFOLDS		
2-1/2 x 3 x 9 1750 R.P.M.	182	3	27AC	11-3/4	38-13/16	43-5/16	13-1/16	9-3/16	3-7/8	36	4		
	182	3	CP	11-3/4	40-15/16	45-7/16	13-1/16	9-3/16	3-7/8	36			
	182	3	DP	11-3/4	40-1/8	44-5/8	13-1/16	9-3/16	3-7/8	36			
	182	3	EP	11-3/4	45-11/16	50-3/16	13-1/16	9-3/16	3-7/8	36			
	184	5	27AC	11-3/4	38-13/16	43-5/16	13-1/16	9-3/16	3-7/8	36			
	184	5	CP	11-3/4	40-15/16	45-7/16	13-1/16	9-3/16	3-7/8	36			
	184	5	DP	11-3/4	40-1/8	44-5/8	13-1/16	9-3/16	3-7/8	36			
	184	5	EP	11-3/4	45-11/16	50-3/16	13-1/16	9-3/16	3-7/8	36			
	213	7-1/2	EP	11-3/4	45-11/16	50-3/16	13-1/16	3-13/16	9-1/4	37-3/4			
	182	3	DP	11-3/4	40-7/8	45-7/8	13-9/16	9-3/16	3-7/8	36-1/2		5	
	182	3	EP	11-3/4	46-3/16	51-3/16	13-9/16	9-3/16	3-7/8	36-1/2			
	184	5	DP	11-3/4	40-7/8	45-7/8	13-9/16	9-3/16	3-7/8	36-1/2			
	184	5	EP	11-3/4	46-3/16	51-3/16	13-9/16	9-3/16	3-7/8	36-1/2		6	
	213	7-1/2	EP	11-3/4	46-3/16	51-3/16	13-9/16	3-13/16	9-3/4	38-1/4			
184	5	EP	11-3/4	46-11/16	52-3/16	14-1/16	9-3/16	3-7/8	37				
213	7-1/2	EP	11-3/4	46-11/16	52-3/16	14-1/16	3-13/16	10-1/4	38-3/4	4			
2 x 3 x 11 1750 R.P.M.	213	7-1/2	27AC	12-1/4	44-1/16	48-9/16	13-7/16	3-7/8	9-9/16		38-1/16		
	213	7-1/2	CP	12-1/4	39-3/16	43-11/16	13-7/16	3-7/8	9-9/16		38-1/16		
	213	7-1/2	DP	12-1/4	44-3/8	48-7/8	13-7/16	3-7/8	9-9/16		38-1/16		
	215	10	DP	12-1/4	44-3/8	48-7/8	13-7/16	3-1/8	10-5/16		40-1/16		
	213	7-1/2	EP	12-1/4	46-11/16	51-3/16	13-7/16	3-7/8	9-9/16		38-1/16		
	215	10	EP	12-1/4	46-11/16	51-3/16	13-7/16	3-1/8	10-5/16		40-1/16		
	213	7-1/2	EP	12-1/4	47-3/16	52-3/16	13-15/16	3-7/8	10-1/16		38-1/16		
	215	10	EP	12-1/4	47-3/16	52-3/16	13-15/16	3-1/8	10-13/16		40-1/16		
	213	7-1/2	EP	12-1/4	47-11/16	53-3/16	14-7/16	3-7/8	10-9/16		38-1/16		
	215	10	EP	12-1/4	47-11/16	53-3/16	14-7/16	3-1/8	11-5/16		40-1/16		
	1-1/2 x 2 x 12 1750 R.P.M.	213	7-1/2	27AA	13	36-5/8	41-5/8	11-5/16	3-15/16		7-3/8	35-7/8	4
		213	7-1/2	AP	13	39-11/16	44-3/16	11-5/16	3-15/16		7-3/8	35-7/8	
		213	7-1/2	27AB	13	42-3/8	46-7/8	11-5/16	3-15/16		7-3/8	35-7/8	
		213	7-1/2	BP	13	36-3/4	41-1/4	11-5/16	3-15/16	7-3/8	35-7/8		
213		7-1/2	27AC	13	43-9/16	48-1/16	11-5/16	3-15/16	7-3/8	35-7/8			
213		7-1/2	CP	13	45-1/4	49-3/4	11-5/16	3-15/16	7-3/8	35-7/8			
213		7-1/2	DP	13	48	52-1/2	11-5/16	3-15/16	7-3/8	35-7/8			
215		10	27AC	13	43-9/16	48-1/16	11-5/16	3-13/16	8-1/8	37-7/8			
215		10	CP	13	45-1/4	49-3/4	11-5/16	3-13/16	8-1/8	37-7/8			
215		10	DP	13	48	52-1/2	11-5/16	3-13/16	8-1/8	37-7/8			

NOTES:

1. ALL DIMENSIONS IN INCHES.
2. DIMENSIONS MAY VARY ± 1/2.
3. NOT FOR CONSTRUCTION PURPOSES UNLESS CERTIFIED.
4. DISCHARGE AND SUCTION FLANGES AMERICAN STANDARD FLAT FACE 125#.
5. 1 GROUT HOLE IS PROVIDED IN TOP OF BASE.

PRESSURE REDUCING VALVES									
DIRECT ACTING					PILOT OPERATED				
SIZE	1-1/2	2	2-1/2	3	2-1/2	3	1-1/4	1-1/2	4
CODE	27AA	27AB	27AC	CP	DP	EP	AP	BP	FP

AURORA MODEL 763 PUMPS

AURORA - PC

TRIPLEX - 1750 R.P.M.

PRESSURE CONTROL SYSTEMS

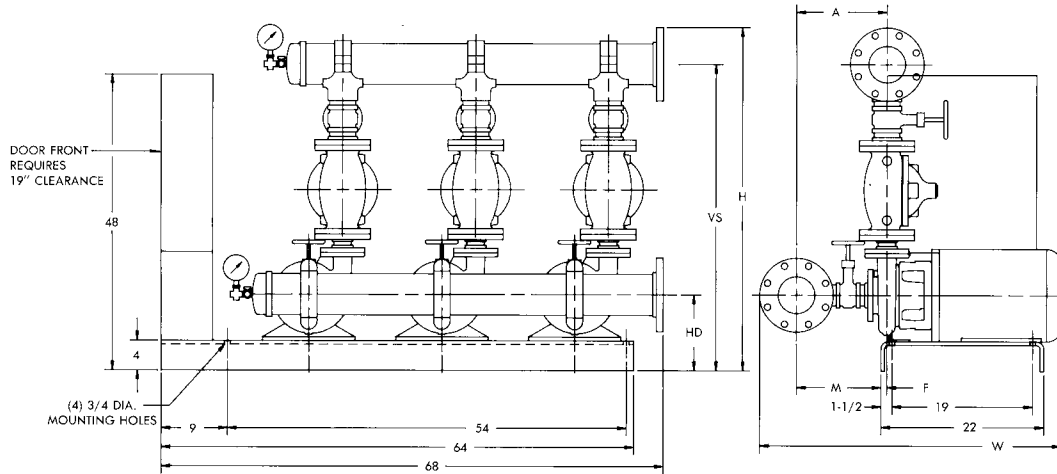

PUMP SIZE	MTR. FR.	H.P.	P R V	HD	VS	H	A	F	M	W	SUCTION & DISCHARGE MANIFOLDS
2-1/2 x 3 x 12 1750 R.P.M.	254	15	DP	13-1/4	42-5/8	47-1/8	13-1/16	9/16	12-1/2	41-7/8	4
	213	7-1/2	EP	13-1/4	48-3/16	52-11/16	13-1/16	3-11/16	9-3/8	37-7/8	
	215	10	EP	13-1/4	48-3/16	52-11/16	13-1/16	2-15/16	10-1/8	39-7/8	
	254	15	EP	13-1/4	48-3/16	52-11/16	13-1/16	9/16	12-1/2	41-7/8	
	213	7-1/2	EP	13-1/4	48-11/16	53-11/16	13-9/16	3-11/16	9-7/8	38-7/8	5
	215	10	EP	13-1/4	48-11/16	53-11/16	13-9/16	2-15/16	10-5/8	40-7/8	
	254	15	EP	13-1/4	48-11/16	53-11/16	13-9/16	9/16	13	42-7/8	
	256	20	EP	13-1/4	48-11/16	53-11/16	13-9/16	13/16†	14-3/8	46-7/8	
	215	10	EP	13-1/4	49-3/16	54-11/16	14-1/16	2-15/16	11-1/8	41-7/8	6
	254	15	EP	13-1/4	49-3/16	54-11/16	14-1/16	9/16	13-1/2	43-7/8	
	256	20	EP	13-1/4	49-3/16	54-11/16	14-1/16	13/16†	14-7/8	47-7/8	
	254	15	FP	13-1/4	56-11/16	62-3/16	14-1/16	9/16	13-1/2	43-7/8	
256	20	FP	13-1/4	56-11/16	62-3/16	14-1/16	13/16†	14-7/8	47-7/8		

NOTES:

1. ALL DIMENSIONS IN INCHES.
2. DIMENSIONS MAY VARY ±1/2.
3. NOT FOR CONSTRUCTION PURPOSES UNLESS CERTIFIED.
4. DISCHARGE AND SUCTION FLANGES ANSI STANDARD FLAT FACE 125#.
5. 1 GROUT HOLE IS PROVIDED IN TOP OF BASE.

PRESSURE REDUCING VALVES										
DIRECT ACTING					PILOT OPERATED					
SIZE	1-1/2	2	2-1/2	3	2	2-1/2	3	1-1/4	1-1/2	4
CODE	27AA	27AB	27AC		CP	DP	EP	AP	BP	FP

†DISCHARGE CENTERLINE, "F" DIMENSION IS LEFT OF BASE FOR THESE PUMP SELECTIONS ONLY.

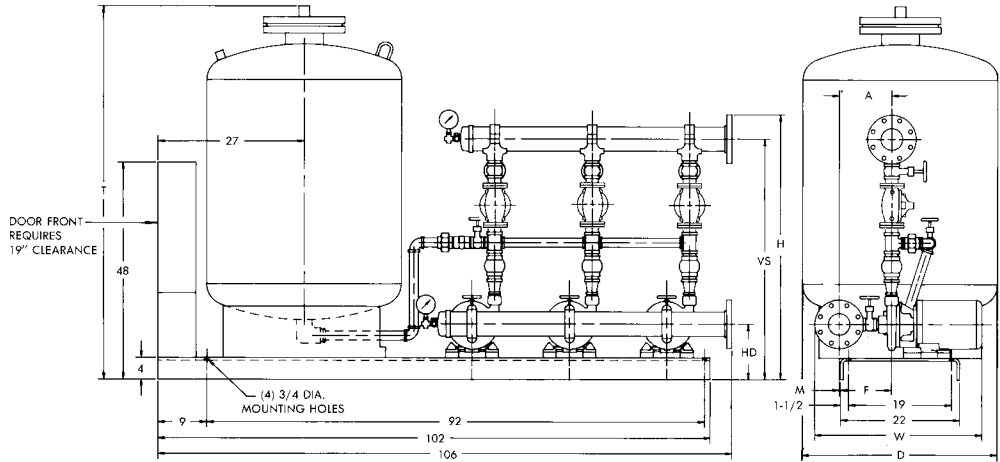

†DISCHARGE CENTERLINE, "F" DIMENSION IS LEFT OF BASE FOR THESE PUMP SELECTIONS ONLY.

PUMP SIZE	MTR. FR.	H.P.	P R V	HD	VS	H	A	F	M	W	SUCTION & DISCHARGE MANIFOLDS
1-1/4 x 1-1/2 x 7 3500 R.P.M.	145	2	27AA	10-1/4	42-3/4	47-1/4	10-11/16	9-7/16	1-1/4	33-3/8	4
	145	2	AP	10-1/4	39-5/16	43-13/16	10-11/16	9-7/16	1-1/4	33-3/8	
	182	3	27AB	10-1/4	42-3/4	47-1/4	10-11/16	9-7/16	1-1/4	33-3/8	
	182	3	AP	10-1/4	39-5/16	43-13/16	10-11/16	9-7/16	1-1/4	33-3/8	
	182	3	27AB	10-1/4	46-3/8	50-7/8	10-11/16	9-7/16	1-1/4	33-3/8	
	182	3	BP	10-1/4	43	47-1/2	10-11/16	9-7/16	1-1/4	33-3/8	
	182	3	27AC	10-1/4	49-3/16	53-11/16	10-11/16	9-7/16	1-1/4	33-3/8	
	182	3	CP	10-1/4	49-1/4	53-3/4	10-11/16	9-7/16	1-1/4	33-3/8	
	184	5	27AA	10-1/4	42-3/4	47-1/4	10-11/16	9-7/16	1-1/4	33-3/8	
	184	5	AP	10-1/4	39-5/16	43-13/16	10-11/16	9-7/16	1-1/4	33-3/8	
	184	5	27AB	10-1/4	46-3/8	50-7/8	10-11/16	9-7/16	1-1/4	33-3/8	
	184	5	BP	10-1/4	43	47-1/2	10-11/16	9-7/16	1-1/4	33-3/8	
	184	5	27AC	10-1/4	49-3/16	53-11/16	10-11/16	9-7/16	1-1/4	33-3/8	
	184	5	CP	10-1/4	49-1/4	53-3/4	10-11/16	9-7/16	1-1/4	33-3/8	
	213	7-1/2	27AB	10-1/4	46-3/8	50-7/8	10-11/16	4-1/8	6-9/16	35-1/16	
	213	7-1/2	BP	10-1/4	43	47-1/2	10-11/16	4-1/8	6-9/16	35-1/16	
	213	7-1/2	27AC	10-1/4	49-3/16	53-11/16	10-11/16	4-1/8	6-9/16	35-1/16	
	213	7-1/2	CP	10-1/4	49-1/4	53-3/4	10-11/16	4-1/8	6-9/16	35-1/16	
1-1/2 x 2 x 7 3500 R.P.M.	184	5	CP	10-1/4	49-1/8	53-5/8	11-1/16	9-3/8	1-11/16	33-13/16	4
	184	5	DP	10-1/4	53-5/8	58-1/8	11-1/16	9-3/8	1-11/16	33-13/16	
	213	7-1/2	27AC	10-1/4	49-7/16	53-15/16	11-1/16	4-1/16	7	35-1/2	
	213	7-1/2	CP	10-1/4	49-1/8	53-5/8	11-1/16	4-1/16	7	35-1/2	
	213	7-1/2	DP	10-1/4	53-5/8	58-1/8	11-1/16	4-1/16	7	35-1/2	
	215	10	27AC	10-1/4	49-7/16	53-15/16	11-1/16	3-5/16	7-3/4	37-1/2	
	215	10	CP	10-1/4	49-1/8	53-5/8	11-1/16	3-5/16	7-3/4	37-1/2	
	215	10	DP	10-1/4	53-5/8	58-1/8	11-1/16	3-5/16	7-3/4	37-1/2	
2 x 2-1/2 x 7A 3500 R.P.M.	184	5	EP	10-1/4	53-5/16	57-13/16	12	9-1/4	2-3/4	34-7/8	4
	213	7-1/2	EP	10-1/4	53-5/16	57-13/16	12	3-15/16	8-1/16	36-9/16	
	215	10	EP	10-1/4	53-5/16	57-13/16	12	3-3/16	8-13/16	38-9/16	
	254	15	DP	10-1/4	50-3/4	55-1/4	12	13/16	11-3/16	40-9/16	
	254	15	EP	10-1/4	53-5/16	57-13/16	12	13/16	11-3/16	40-9/16	
	256	20	EP	10-1/4	53-5/16	57-13/16	12	9/16†	12-9/16	44-9/16	
	213	7-1/2	EP	10-1/4	54-5/16	59-5/16	12-3/4	3-15/16	8-13/16	37-13/16	5
	215	10	EP	10-1/4	54-5/16	59-5/16	12-3/4	3-3/16	9-9/16	39-13/16	
	254	15	EP	10-1/4	54-5/16	59-5/16	12-3/4	13/16	11-15/16	41-13/16	
	256	20	EP	10-1/4	54-5/16	59-5/16	12-3/4	9/16†	13-5/16	45-13/16	
	213	7-1/2	EP	10-1/4	54-13/16	60-5/16	13-1/8	3-15/16	9-3/16	38-11/16	
	215	10	EP	10-1/4	54-13/16	60-5/16	13-1/8	3-3/16	9-15/16	40-11/16	
	254	15	EP	10-1/4	54-13/16	60-5/16	13-1/8	13/16	12-5/16	42-11/16	
	256	20	EP	10-1/4	54-13/16	68-5/16	13-1/8	9/16†	13-11/16	46-11/16	

PRESSURE REDUCING VALVES										
DIRECT ACTING					PILOT OPERATED					
SIZE	1-1/2	2	2-1/2	2	2-1/2	3	1-1/4	1-1/2	4	
CODE	27AA	27AB	27AC	CP	DP	EP	AP	BP	FP	

TANK SIZE (GALLONS)	79	106	132	158	170	211
T	59	53	61	69	80	67
D	24	30	30	30	30	36

NOTES:

1. ALL DIMENSIONS IN INCHES.
2. DIMENSIONS MAY VARY ±1/2.
3. NOT FOR CONSTRUCTION PURPOSES UNLESS CERTIFIED.
4. DISCHARGE AND SUCTION FLANGES ANSI STANDARD FLAT FACE 125#.
5. 1 GROUT HOLE IS PROVIDED IN TOP OF BASE.

AURORA MODEL 763 PUMPS

AURORA - PC

TRIPLEX - WITH TANK

3500 R.P.M.

PRESSURE CONTROL SYSTEMS

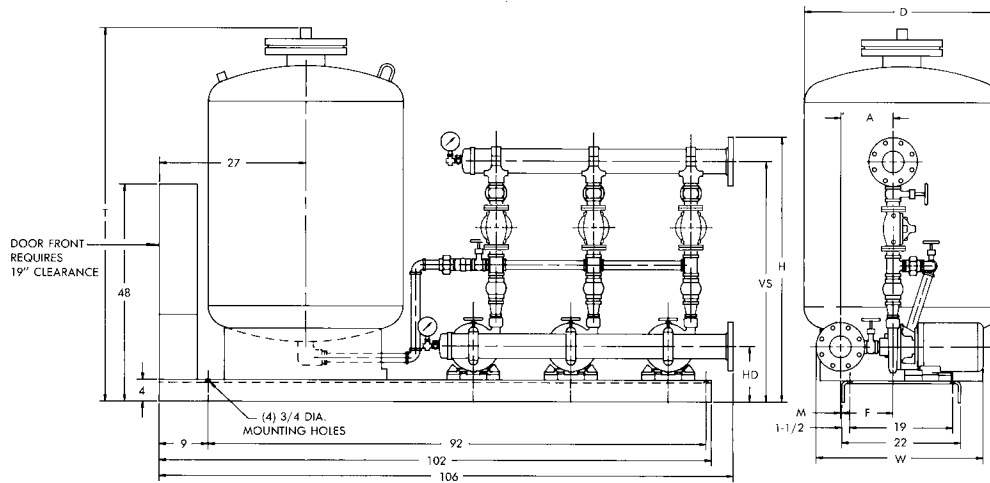

PUMP SIZE	MTR. FR.	H.P.	P R V	HD	VS	H	A	F	M	W	SUCTION & DISCHARGE MANIFOLDS
2-1/2 x 3 x 7B 3500 R.P.M.	254	15	EP	11-1/4	55-5/16	59-13/16	13-1/16	11/16	12-3/8	41-3/4	4
	254	15	EP	11-1/4	55-13/16	60-13/16	13-9/16	11/16	12-7/8	42-3/4	5
	256	20	EP	11-1/4	55-13/16	60-13/16	13-9/16	11/16†	14-1/4	46-3/4	6
	215	10	FP	11-1/4	66-1/16	71-9/16	14-1/16	3-1/16	11	41-3/4	
	254	15	FP	11-1/4	66-1/16	71-9/16	14-1/16	11/16	13-3/8	43-3/4	
	256	20	FP	11-1/4	66-1/16	71-9/16	14-1/16	11/16†	14-3/4	47-3/4	
	254	15	EP	11-1/4	56-5/16	61-13/16	14-1/16	11/16	13-3/8	43-3/4	
256	20	EP	11-1/4	56-5/16	61-13/16	14-1/16	11/16†	14-3/4	47-3/4		
1-1/2 x 2 x 9C 3500 R.P.M.	213	7-1/2	27AB	11-1/4	50-13/16	55-5/16	11-3/16	4-1/16	7-1/8	35-5/8	4
	213	7-1/2	BP	11-1/4	44	48-1/2	11-3/16	4-1/16	7-1/8	35-5/8	
	215	10	27AB	11-1/4	50-13/16	55-5/16	11-3/16	3-5/16	7-7/8	37-5/8	
	215	10	27AC	11-1/4	51-13/16	56-5/16	11-3/16	3-5/16	7-7/8	37-5/8	
	215	10	CP	11-1/4	53-5/16	57-13/16	11-3/16	3-5/16	7-7/8	37-5/8	
	215	10	BP	11-1/4	44	48-1/2	11-3/16	3-5/16	7-7/8	37-5/8	
	254	15	27AB	11-1/4	50-13/16	55-5/16	11-3/16	15/16	10-1/4	39-5/8	
	254	15	27AC	11-1/4	51-13/16	56-5/16	11-3/16	15/16	10-1/4	39-5/8	
	254	15	CP	11-1/4	53-5/16	57-13/16	11-3/16	15/16	10-1/4	39-5/8	
	254	15	DP	11-1/4	56	60-1/2	11-3/16	15/16	10-1/4	39-5/8	
	254	15	BP	11-1/4	44	48-1/2	11-3/16	15/16	10-1/4	39-5/8	
	256	20	27AC	11-1/4	51-13/16	56-5/16	11-3/16	7/16†	11-5/8	43-5/8	
	256	20	CP	11-1/4	53-5/16	57-13/16	11-3/16	7/16†	11-5/8	43-5/8	
	256	20	DP	11-1/4	56	60-1/2	11-3/16	7/16†	11-5/8	43-5/8	
2 x 2-1/2 x 9 3500 R.P.M.	254	15	EP	11-3/4	56-11/16	61-3/16	12	13/16	11-3/16	40-9/16	4
	256	20	EP	11-3/4	56-11/16	61-3/16	12	9/16†	12-9/16	44-9/16	5
	254	15	EP	11-3/4	57-3/16	62-3/16	12-3/4	13/16	11-15/16	41-13/16	
	256	20	EP	11-3/4	57-3/16	62-3/16	12-3/4	9/16†	13-5/16	45-13/16	6
	254	15	EP	11-3/4	57-11/16	63-3/16	13-1/8	13/16	12-5/16	42-11/16	
	256	20	EP	11-3/4	57-11/16	63-3/16	13-1/8	9/16†	13-11/16	46-11/16	

PRESSURE REDUCING VALVES									
DIRECT ACTING					PILOT OPERATED				
SIZE	1-1/2	2	2-1/2	2	2-1/2	3	1-1/4	1-1/2	4
CODE	27AA	27AB	27AC	CP	DP	EP	AP	BP	FP

TANK SIZE (GALLONS)	79	106	132	158	170	211
T	59	53	61	69	80	67
D	24	30	30	30	30	36

NOTES:

- ALL DIMENSIONS IN INCHES.
- DIMENSIONS MAY VARY ±1/2.
- NOT FOR CONSTRUCTION PURPOSES UNLESS CERTIFIED.
- DISCHARGE AND SUCTION FLANGES ANSI STANDARD FLAT FACE 125#.
- 1 GROUT HOLE IS PROVIDED IN TOP OF BASE.

†DISCHARGE CENTERLINE, "F" DIMENSION IS LEFT OF BASE FOR THESE PUMP SELECTIONS ONLY.

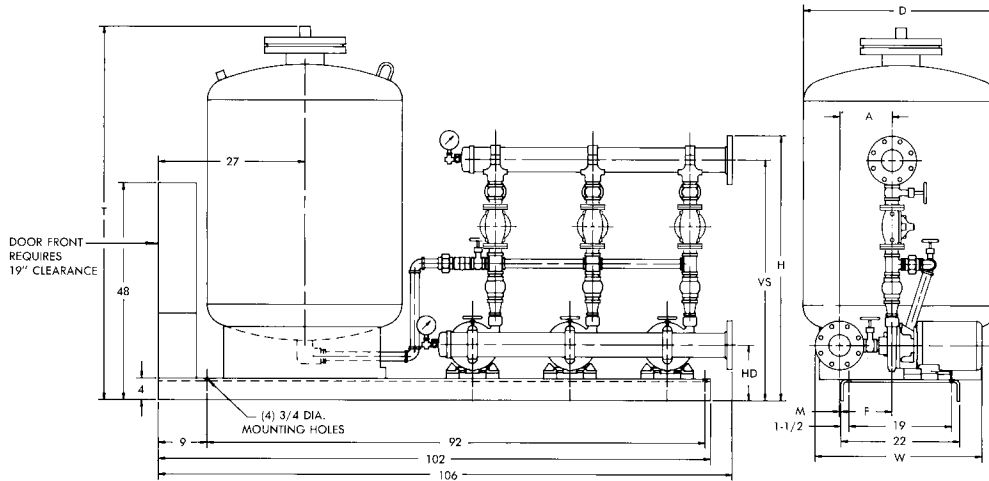

PUMP SIZE	MTR. FR.	H.P.	P R V	HD	VS	H	A	F	M	W	SUCTION & DISCHARGE MANIFOLDS
1-1/2 x 2 x 9C 1750 R.P.M.	143	1	27AA	11-1/4	43-7/8	48-3/8	11-13/16	10-3/16	1	32-7/8	4
	143	1	27AB	11-1/4	50-13/16	55-5/16	11-13/16	10-3/16	1	32-7/8	
	143	1	AP	11-1/4	46-7/16	50-15/16	11-13/16	10-3/16	1	32-7/8	
	143	1	BP	11-1/4	44	48-1/2	11-13/16	10-3/16	1	32-7/8	
	145	1-1/2	27AA	11-1/4	43-7/8	48-3/16	11-13/16	10-3/16	1	33-7/8	
	145	1-1/2	27AB	11-1/4	50-13/16	55-5/16	11-13/16	10-3/16	1	33-7/8	
	145	1-1/2	AP	11-1/4	46-7/16	50-15/16	11-13/16	10-3/16	1	33-7/8	
	145	1-1/2	BP	11-1/4	44	48-1/2	11-13/16	10-3/16	1	33-7/8	
	145	2	27AA	11-1/4	43-7/8	48-3/8	11-13/16	10-3/16	1	33-7/8	
	145	2	27AB	11-1/4	50-13/16	55-5/16	11-13/16	10-3/16	1	33-7/8	
	145	2	27AC	11-1/4	51-13/16	56-5/16	11-13/16	10-3/16	1	33-7/8	
	145	2	CP	11-1/4	53-5/16	57-13/16	11-13/16	10-3/16	1	33-7/8	
	145	2	AP	11-1/4	46-7/16	50-15/16	11-13/16	10-3/16	1	33-7/8	
	145	2	BP	11-1/4	44	48-1/2	11-13/16	10-3/16	1	33-7/8	
	182	3	27AA	11-1/4	43-7/8	48-3/8	11-13/16	10-3/16	1	33-7/8	
	182	3	27AB	11-1/4	50-13/16	55-5/16	11-13/16	10-3/16	1	33-7/8	
	182	3	27AC	11-1/4	51-13/16	56-5/16	11-13/16	10-3/16	1	33-7/8	
	182	3	CP	11-1/4	53-5/16	57-13/16	11-13/16	10-3/16	1	33-7/8	
	182	3	AP	11-1/4	46-7/16	50-15/16	11-13/16	10-3/16	1	33-7/8	
	182	3	BP	11-1/4	44	48-1/2	11-13/16	10-3/16	1	33-7/8	
2 x 2-1/2 x 9 1750 R.P.M.	145	2	27AC	11-3/4	53-5/16	57-13/16	12	9-5/16	2-11/16	34-13/16	4
	145	2	CP	11-3/4	48-7/8	53-3/8	12	9-5/16	2-11/16	34-13/16	
	145	2	DP	11-3/4	53-5/8	58-1/8	12	9-5/16	2-11/16	34-13/16	
	182	3	27AB	11-3/4	48-7/8	53-3/8	12	9-5/16	2-11/16	34-13/16	
	182	3	27AC	11-3/4	53-5/16	57-13/16	12	9-5/16	2-11/16	34-13/16	
	182	3	CP	11-3/4	48-7/8	53-3/8	12	9-5/16	2-11/16	34-13/16	
	182	3	DP	11-3/4	53-5/8	58-1/8	12	9-5/16	2-11/16	34-13/16	
	182	3	BP	11-3/4	48-5/16	52-13/16	12	9-5/16	2-11/16	34-13/16	
	184	5	27AC	11-3/4	53-5/16	57-13/16	12	9-5/16	2-11/16	34-13/16	
	184	5	CP	11-3/4	48-7/8	53-3/8	12	9-5/16	2-11/16	34-13/16	
184	5	DP	11-3/4	53-5/8	58-1/8	12	9-5/16	2-11/16	34-13/16		

PRESSURE REDUCING VALVES									
DIRECT ACTING					PILOT OPERATED				
SIZE	1-1/2	2	2-1/2	2	2-1/2	3	1-1/4	1-1/2	4
CODE	27AA	27AB	27AC	CP	DP	EP	AP	BP	FP

TANK SIZE (GALLONS)	79	106	132	158	170	211
T	59	53	61	69	80	67
D	24	30	30	30	30	36

NOTES:

1. ALL DIMENSIONS IN INCHES.
2. DIMENSIONS MAY VARY ±1/2.
3. NOT FOR CONSTRUCTION PURPOSES UNLESS CERTIFIED.
4. DISCHARGE AND SUCTION FLANGES ANSI STANDARD FLAT FACE 125#.
5. 1 GROUT HOLE IS PROVIDED IN TOP OF BASE.

AURORA MODEL 763 PUMPS - AURORA - PC TRIPLEX - WITH TANK 1750 R.P.M. PRESSURE CONTROL SYSTEMS

SECTION 750/760 PAGE 227

DATED JANUARY 1999

SUPERSEDES PAGE 227

DATED JUNE 1994

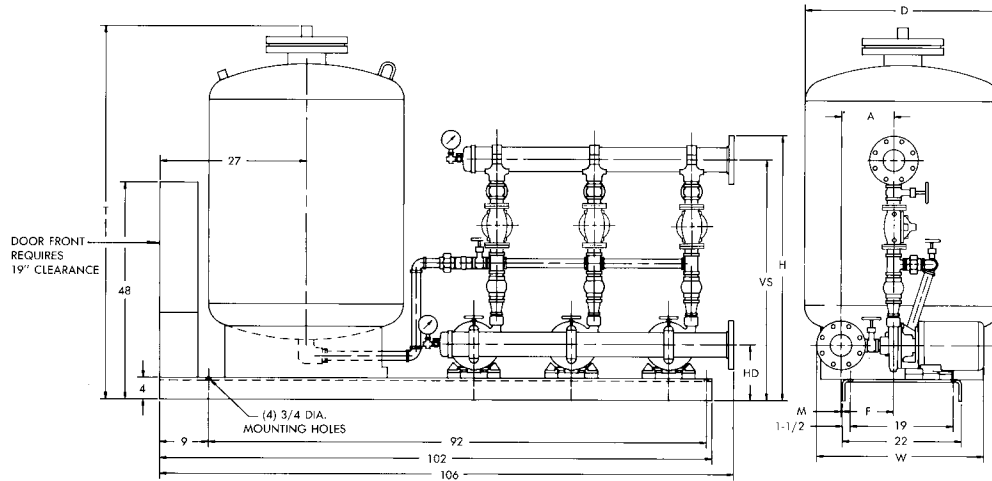

PUMP SIZE	MTR. FR.	H.P.	P R V	HD	VS	H	A	F	M	W	SUCTION & DISCHARGE MANIFOLDS		
2-1/2 x 3 x 9 1750 R.P.M.	182	3	27AC	11-3/4	49-9/16	54-1/16	13-1/16	9-3/16	3-7/8	36	4		
	182	3	CP	11-3/4	52-1/8	56-5/8	13-1/16	9-3/16	3-7/8	36			
	182	3	DP	11-3/4	50-7/8	55-3/8	13-1/16	9-3/16	3-7/8	36			
	182	3	EP	11-3/4	57-3/16	61-11/16	13-1/16	9-3/16	3-7/8	36			
	184	5	27AC	11-3/4	49-9/16	54-1/16	13-1/16	9-3/16	3-7/8	36			
	184	5	CP	11-3/4	52-1/8	56-5/8	13-1/16	9-3/16	3-7/8	36			
	2 x 3 x 11 1750 R.P.M.	184	5	DP	11-3/4	50-7/8	55-3/8	13-1/16	9-3/16	3-7/8	36	5	
		184	5	EP	11-3/4	57-3/16	61-11/16	13-1/16	9-3/16	3-7/8	36		
		213	7-1/2	EP	11-3/4	57-3/16	61-11/16	13-9/16	3-13/16	9-1/4	37-3/4		
		182	3	DP	11-3/4	51-5/8	56-5/8	13-9/16	9-3/16	3-7/8	36-1/2		
		182	3	EP	11-3/4	57-11/16	62-11/16	13-9/16	9-3/16	3-7/8	36-1/2		
		184	5	DP	11-3/4	51-5/8	56-5/8	13-9/16	9-3/16	3-7/8	36-1/2		
1-1/2 x 2 x 12 1750 R.P.M.		184	5	EP	11-3/4	57-11/16	62-11/16	13-9/16	9-3/16	3-7/8	36-1/2	6	
		213	7-1/2	EP	11-3/4	57-11/16	62-11/16	13-9/16	3-13/16	9-3/4	38-1/4		
		184	5	EP	11-3/4	58-3/16	63-11/16	14-1/16	9-3/16	3-7/8	37		
		213	7-1/2	EP	11-3/4	58-3/16	63-11/16	14-1/16	3-13/16	10-1/4	38-3/4		
		213	7-1/2	27AC	12-1/4	54-13/16	59-5/16	13-7/16	3-7/8	9-9/16	38-1/16		4
		213	7-1/2	CP	12-1/4	50-3/8	54-7/8	13-7/16	3-7/8	9-9/16	38-1/16		
	213	7-1/2	DP	12-1/4	55-1/8	59-5/8	13-7/16	3-7/8	9-9/16	38-1/16			
	215	10	DP	12-1/4	55-1/8	59-5/8	13-7/16	3-1/8	10-5/16	40-1/16			
	213	7-1/2	EP	12-1/4	58-3/16	62-11/16	13-7/16	3-7/8	9-9/16	38-1/16			
	215	10	EP	12-1/4	58-3/16	62-11/16	13-7/16	3-1/8	10-5/16	40-1/16			
	1-1/2 x 2 x 12 1750 R.P.M.	213	7-1/2	EP	12-1/4	58-11/16	63-11/16	13-15/16	3-7/8	10-1/16	38-1/16	5	
		215	10	EP	12-1/4	58-11/16	63-11/16	13-15/16	3-1/8	10-13/16	40-1/16		
213		7-1/2	EP	12-1/4	59-3/16	64-11/16	14-7/16	3-7/8	10-9/16	38-1/16	6		
215		10	EP	12-1/4	59-3/16	64-11/16	14-7/16	3-1/8	11-5/16	40-1/16			
213		7-1/2	27AA	13	46-5/8	51-1/8	11-5/16	3-15/16	7-3/8	35-7/8			4
213		7-1/2	AP	13	49-3/16	53-11/16	11-5/16	3-15/16	7-3/8	35-7/8			
213		7-1/2	27AB	13	53-9/16	58-1/8	11-5/16	3-15/16	7-3/8	35-7/8			
213		7-1/2	BP	13	46-3/4	51-1/4	11-5/16	3-15/16	7-3/8	35-7/8			
213		7-1/2	27AC	13	54-5/16	58-13/16	11-5/16	3-15/16	7-3/8	35-7/8			
213		7-1/2	CP	13	56-7/16	60-15/16	11-5/16	3-15/16	7-3/8	35-7/8			
1-1/2 x 2 x 12 1750 R.P.M.		213	7-1/2	DP	13	58-3/4	63-1/4	11-5/16	3-15/16	7-3/8	35-7/8	4	
		215	10	27AC	13	54-5/16	58-13/16	11-5/16	3-3/16	8-1/8	37-7/8		
	215	10	CP	13	56-7/8	60-15/16	11-5/16	3-3/16	8-1/8	37-7/8			
	215	10	DP	13	58-3/4	63-1/4	11-5/16	3-3/16	8-1/8	37-7/8			
	215	10	DP	13	58-3/4	63-1/4	11-5/16	3-3/16	8-1/8	37-7/8			

NOTES:

- ALL DIMENSIONS IN INCHES.
- DIMENSIONS MAY VARY ±1/2.
- NOT FOR CONSTRUCTION PURPOSES UNLESS CERTIFIED.
- DISCHARGE AND SUCTION FLANGES ANSI STANDARD FLAT FACE 125#.
- 1 GROUT HOLE IS PROVIDED IN TOP OF BASE.

PRESSURE REDUCING VALVES									
	DIRECT ACTING					PILOT OPERATED			
SIZE	1-1/2	2	2-1/2	2	2-1/2	3	1-1/4	1-1/2	4
CODE	27AA	27AB	27AC	CP	DP	EP	AP	BP	FP

TANK SIZE (GALLONS)	79	106	132	158	170	211
T	59	53	61	69	80	67
D	24	30	30	30	30	36

PRESSURE CONTROL SYSTEMS

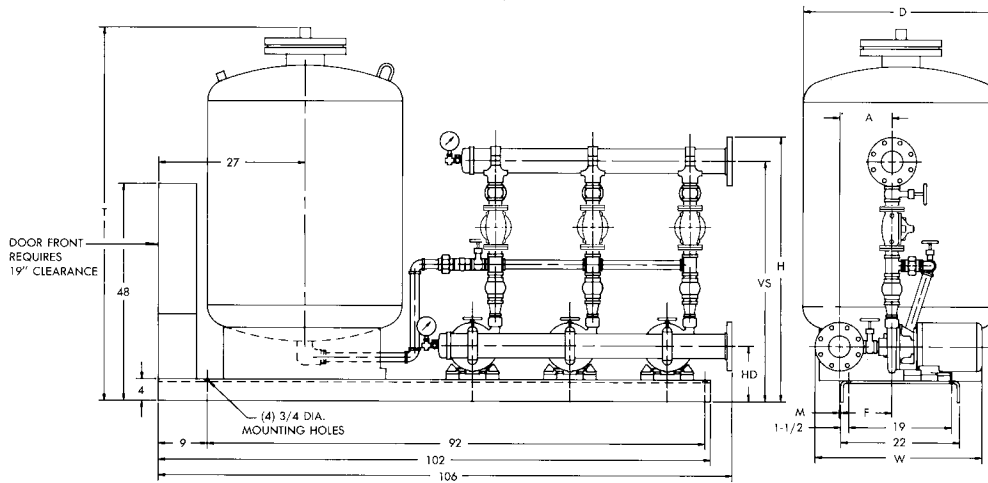

PUMP SIZE	MTR. FR.	H.P.	P R V	HD	VS	H	A	F	M	W	SUCTION & DISCHARGE MANIFOLDS
2-1/2 x 3 x 12 1750 R.P.M.	254	15	DP	13-1/4	53-3/8	57-7/8	13-1/16	9/16	12-1/2	41-7/8	4
	213	7-1/2	EP	13-1/4	59-11/16	64-3/16	13-1/16	3-11/16	9-3/8	37-7/8	
	215	10	EP	13-1/4	59-11/16	64-3/16	13-1/16	2-15/16	10-1/8	39-7/8	
	254	15	EP	13-1/4	59-11/16	64-3/16	13-1/16	9/16	12-1/2	41-7/8	
	213	7-1/2	EP	13-1/4	60-3/16	65-3/16	13-9/16	3-11/16	9-7/8	38-7/8	5
	215	10	EP	13-1/4	60-3/16	65-3/16	13-9/16	2-15/16	10-5/8	40-7/8	
	254	15	EP	13-1/4	60-3/16	65-3/16	13-9/16	9/16	13	42-7/8	
	256	20	EP	13-1/4	60-3/16	65-3/16	13-9/16	13/16†	14-3/8	46-7/8	
	215	10	EP	13-1/4	60-11/16	66-3/16	14-1/16	2-15/16	11-1/8	41-7/8	6
	254	15	EP	13-1/4	60-11/16	66-3/16	14-1/16	9/16	13-1/2	43-7/8	
	256	20	EP	13-1/4	60-11/16	66-3/16	14-1/16	13/16†	14-7/8	47-7/8	
	254	15	FP	13-1/4	70-7/16	75-15/16	14-1/16	9/16	13-1/2	43-7/8	
256	20	FP	13-1/4	70-7/16	75-15/16	14-1/16	13/16†	14-7/8	47-7/8		

PRESSURE REDUCING VALVES									
DIRECT ACTING					PILOT OPERATED				
SIZE	1-1/2	2	2-1/2	2	2-1/2	3	1-1/4	1-1/2	4
CODE	27AA	27AB	27AC	CP	DP	EP	AP	BP	FP

TANK SIZE (GALLONS)	79	106	132	158	170	211
T	59	53	61	69	80	67
D	24	30	30	30	30	36

NOTES:

1. ALL DIMENSIONS IN INCHES.
2. DIMENSIONS MAY VARY ±1/2.
3. NOT FOR CONSTRUCTION PURPOSES UNLESS CERTIFIED.
4. DISCHARGE AND SUCTION FLANGES ANSI STANDARD FLAT FACE 125#.
5. 1 GROUT HOLE IS PROVIDED IN TOP OF BASE.

†DISCHARGE CENTERLINE, "F" DIMENSION IS LEFT OF BASE FOR THESE PUMP SELECTIONS ONLY.

Dated JULY 1989

SUPERSEDES PAGE 403
DATED NOVEMBER 1987

SIZING OF CONSTANT SPEED BOOSTER PUMPS

THERE ARE PRESSURE REDUCING VALVE (PRV) AND PIPING LOSSES WHICH MUST BE ACCOUNTED FOR WHEN SIZING THE PUMPS. THE FOLLOWING EXAMPLE WILL ILLUSTRATE THAT SELECTION PROCESS.

EXAMPLE: SELECT PUMPS FOR A DUPLEX SYSTEM TO SUPPLY 420 G.P.M. AT A BOOST OF 100 FEET.

- 1) DIVIDE THE TOTAL CAPACITY OF 420 G.P.M. BY 2 TO DETERMINE SINGLE PUMP CAPACITY, OR 210 G.P.M. PER PUMP. NOTE: SOME SPECIFICATIONS MAY REQUIRE THAT THE SUM OF THE FLOWS OF THE INDIVIDUAL PUMPS BE GREATER THAN THE TOTAL SYSTEM FLOW. FOR EXAMPLE IT MIGHT STATE THAT EACH PUMP OF A DUPLEX SYSTEM IS CAPABLE OF SUPPLYING 75% OF TOTAL FLOW. ANOTHER SPECIFICATION MIGHT STATE THAT THE FLOW OF EACH PUMP IS TO BE A SPECIFIC PERCENTAGE OF THE TOTAL FLOW. FOR EXAMPLE ONE PUMP AT 20% AND TWO PUMPS AT 40% OF TOTAL FLOW. THESE VARIATIONS WILL DETERMINE THE FLOW REQUIREMENTS FOR EACH PUMP TO BE SELECTED. IT IS LIKELY THAT DIFFERENT PUMP SIZES ARE REQUIRED.
- 2) REFER TO SELECTION CHARTS ON PAGES 397 AND 398 AND DETERMINE THAT A SIZE 2 X 2.5 X 7A PUMP AT 3500 R.P.M. IS IN THE RECOMMENDED SELECTION RANGE FOR THE EXAMPLE HEAD CAPACITY REQUIREMENTS.
- 3) REFER TO THE PERFORMANCE CURVE FOR THAT SIZE PUMP.

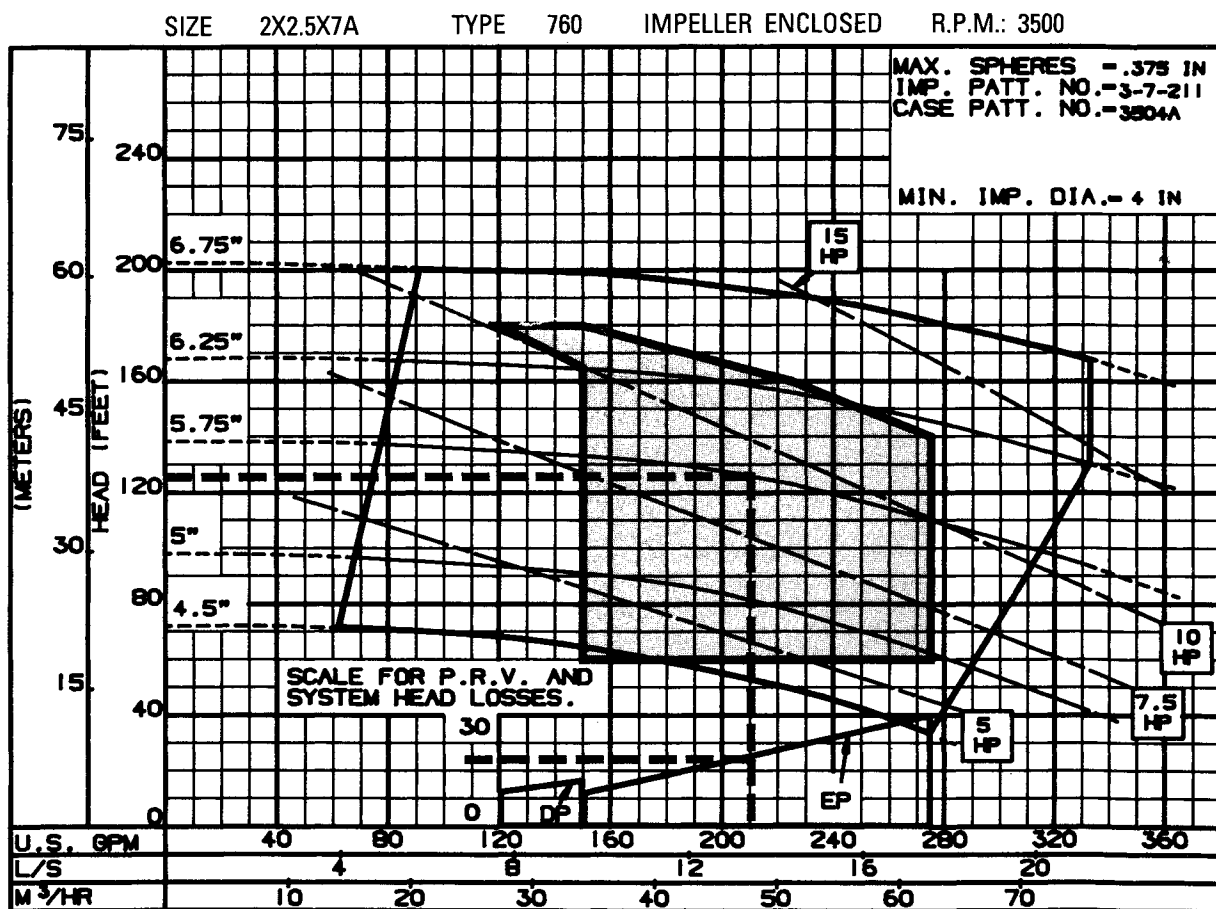

- 3) ENTER CURVE ON LOWER SCALE AT 210 G.P.M. AND READ UP TO THE PRV AND SYSTEM HEAD LOSS CURVE WHICH READS 25 FEET LOSS. ADD THIS AMOUNT TO THE 100 FEET BOOST OR A TOTAL HEAD OF 125 FEET. NOTE: WHEN A HYDROPNEUMATIC TANK IS TO BE ADDED TO THE SYSTEM, MULTIPLY THE LOSS VALVE BY 1.2 TO PICK UP TANK AND ADDITIONAL PIPING LOSSES.
- 5) THE INTERSECTION OF 210 G.P.M. AND 125 FEET HEAD SHOWS 5.75" DIAMETER IMPELLER AND APPROXIMATELY 9.0 BRAKE H.P. REQUIRED. A 10 HOUSEPOWER MOTOR AT 3500 R.P.M. SHOULD BE SELECTED. IF THE SPECIFICATION CALLS FOR NON-OVERLOADING AT ANY POINT ON THE CURVE A LARGER MOTOR MAY NEED TO BE SELECTED.

ap AURORA®

PENTAIR PUMP GROUP

GENERAL INFORMATION

OPERATION OF MODEL 752 DUPLEX UNIT

Your booster system has been sized to maintain a constant discharge pressure by combining constant speed centrifugal pumps with pressure reducing valves on the discharge side of each pump. The lead pump shall run alone to satisfy the system demand until it cannot furnish enough head. As system demand increases, the lag pump is automatically started to maintain sufficient head. When the flow required diminishes to a point where the lead pump alone can maintain pressure, the lag pump is automatically shutdown.

The pressure reducing valves are pilot operated and adjustable, but have been set at the factory for your constant pressure. Each valve automatically modulates to increase or decrease its pressure drop, and thereby maintain a constant pressure in the discharge manifold. Each valve acts as a check valve when its pump is shutdown permitting either pump to maintain manifold pressure.

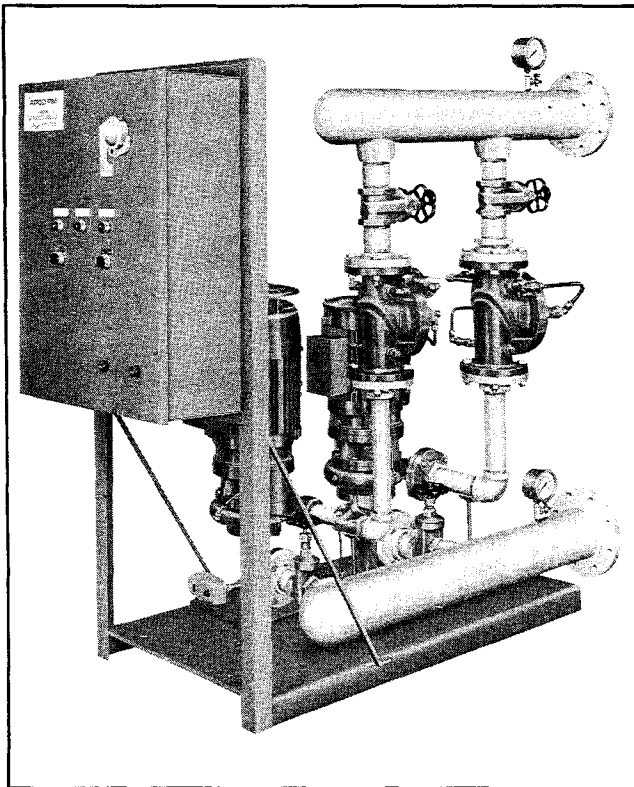

A. Typical duplex system.

OPERATION OF MODEL 753 TRIPLEX UNIT

Your triplex system is identical in principal to the duplex operation explained previously, but has a third pump available when the first two (2) pumps can't handle the minimum pressure required at high flows. These lag pumps are automatically started and stopped as the system flow increases and decreases. (See Figure 1)

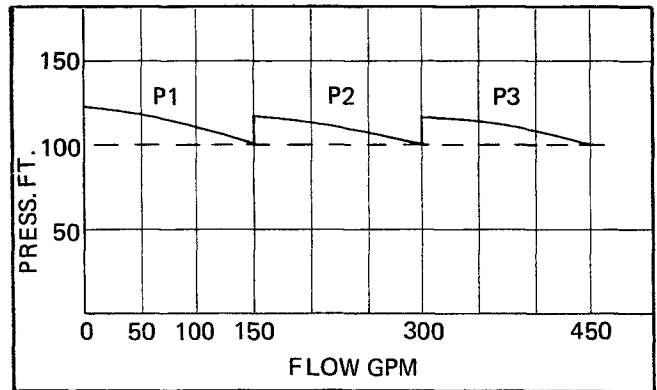

Figure 1. Typical Flow Triplex System

CURRENT SENSING

The automatic starting and stopping of a lag pump is accomplished by utilizing a current sensing monitor inside the control panel. One leg of each motor line is fed through a current transformer and then into the current monitor. The current monitor is factory set at a specific current draw based on the flow and head capacity of the lead pump. Once the current draw reaches this preset value (shown in Figure 2 as current set adjustment #1) a relay is closed and pilot light #1 (see Figure 2) lights up signifying that pump #1 is loaded to capacity. A loaded condition must remain for a 3 second minimum, at which time another relay is closed starting the lag pump. Once the lag pump is started, it remains on for a minimum run time period (Figure 2, adjustment 3) usually preset at about 45 seconds. A second factory adjustment controls at what current the lag pump will no longer be required and then shuts the pump off (Figure 2, adjustment 2, current reset).

A Triplex System will have a second current monitor, which will bring on the 3rd pump when pumps 1 and 2 are loaded and shuts off this pump when it's no longer needed. Refer to Figure B.

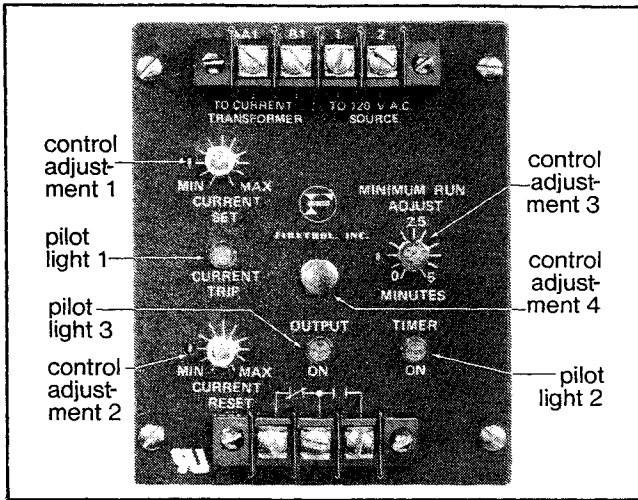
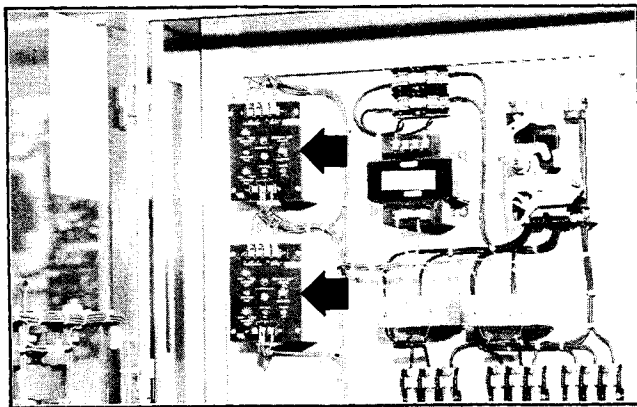

Figure 2. Current Monitor



B. Current monitors for a triplex unit.

is no longer required, the current in the lead motor drops to 90% of its trip setting and shuts off the lag pump. If this slight imbalance isn't put in the system, a balanced pumping system may not shut off at the proper point. (See Figure 4.)

On the other extreme, a duplex unit with a small lead pump and a large lag pump may operate best with the pressure regulating valve set 1 or 2 PSI higher on the lead pump to prevent the lag pump from coming on and driving the lead pump toward premature shut off.

These adjustments can be made in the field, but have been preset at the factory.

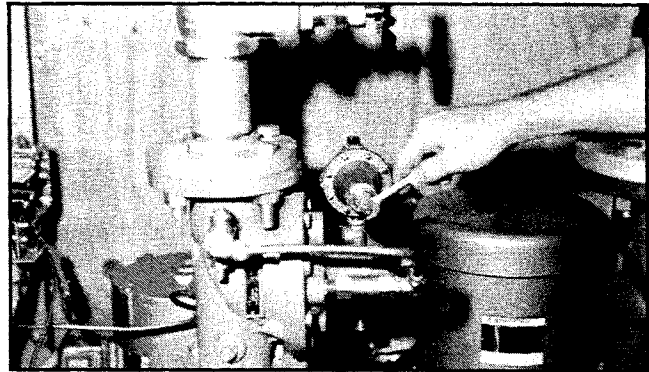

C. PRV adjustment.

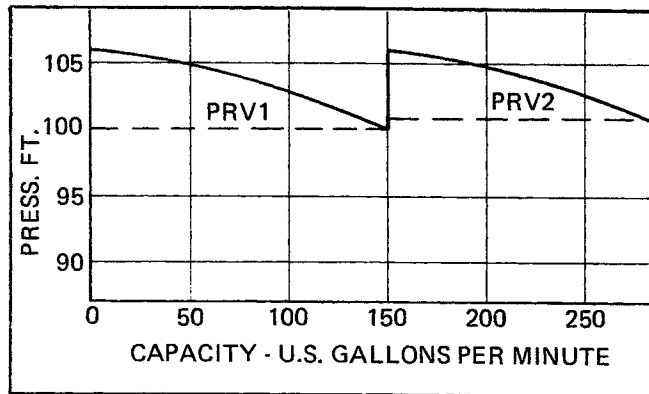

Figure 4.

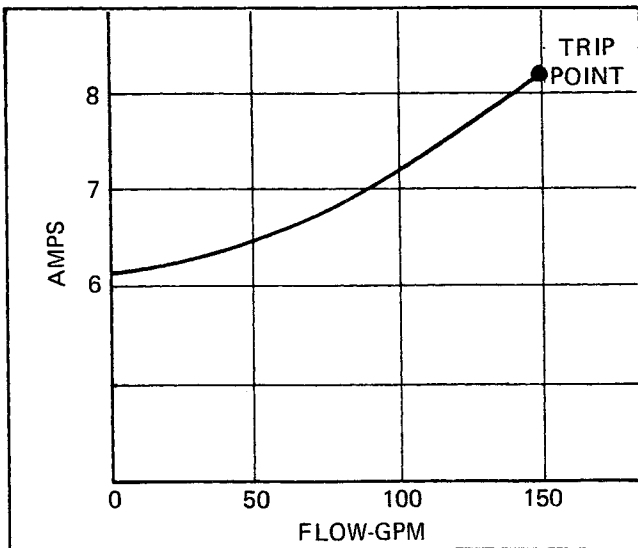

Figure 3. Typical Current Thru One Relay

PERFORMANCE CHARACTERISTICS

Each system will be similar in its method of operation and yet each could be unique in its own characteristics. For example, a duplex system with two identical size pumps and motors may have the pressure regulating control set 1 or 2 PSI higher on the lag pump so that when the lag pump

INSTALLATION

UNCRATING AND INSPECTION

Inspect your APCO-PM Booster System for shipping damage and report such damage to the carrier immediately.

Remove the crating material and pressure gauges shipped loose.

Mount the pressure gauges on each manifold and inspect the booster system a second time, looking inside the control panel for possible damage or loose wires.

Damaged parts should be replaced prior to start-up.

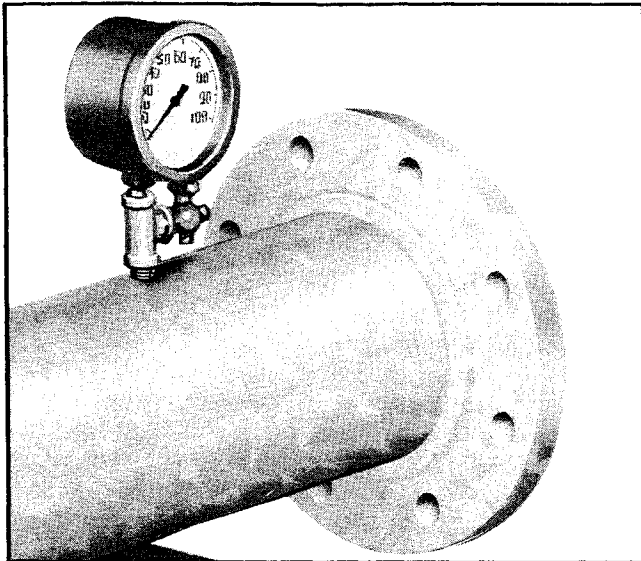

D. Suction gauge mounted.

PIPING & GROUTING

Locate the booster in a location which is most convenient for your hook up to the suction and discharge piping.

Adequately support your piping to the booster to prevent unnecessary stresses on the piping of the booster system. When the booster is properly located and piped into your system, fill the base-plate with grout by blocking off the ends and filling through the 6" grout hole provided in the top of the base. A non-shrinkable type grout is recommended.

WIRING

Before wiring the control panel main disconnect switch check to make sure that your voltage and frequency available agrees with the information on the wiring diagram inside the control panel.

The panel is completely wired and the only wiring required is a feeder line connected through the top or right side of the panel to the top of the main disconnect switch.

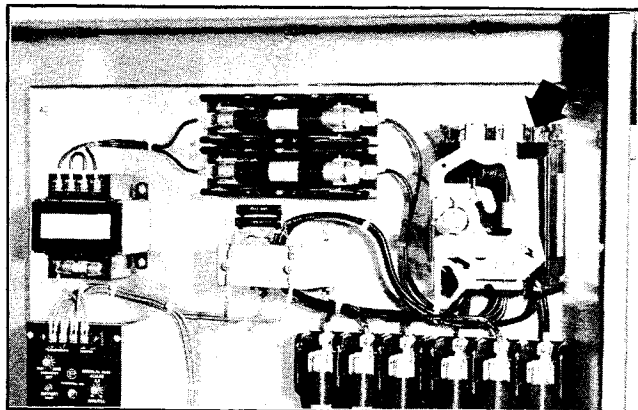

E. Feeder line connection.

After connecting your feeder line, close the panel door, jog the lead motor on and off to see that the motor rotates clockwise, as seen from the top of the motor. If the motor does not run clockwise, switch any two legs of your feeder line. If the lead pump rotates properly, so will the lag pump(s).

CAUTION

NEVER OPERATE THE CONTROL PANEL WITH THE DOOR OPEN.

The main disconnect switch interlocks with the panel door and must be turned off to open the panel door.

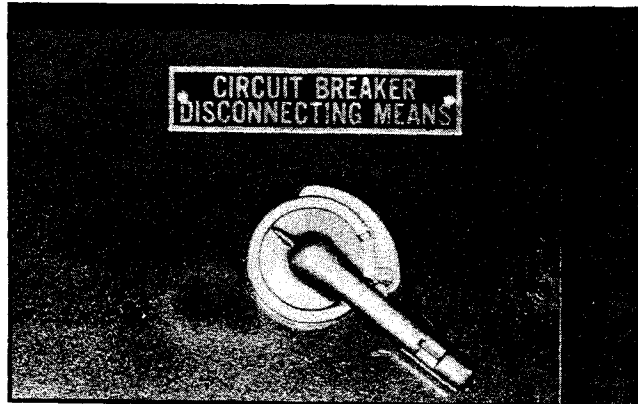

F. Main disconnect switch.

START-UP

1. Open the water supply valve to the suction manifold. The isolating gate valves on each side of the pumps should be checked to make sure they are open.

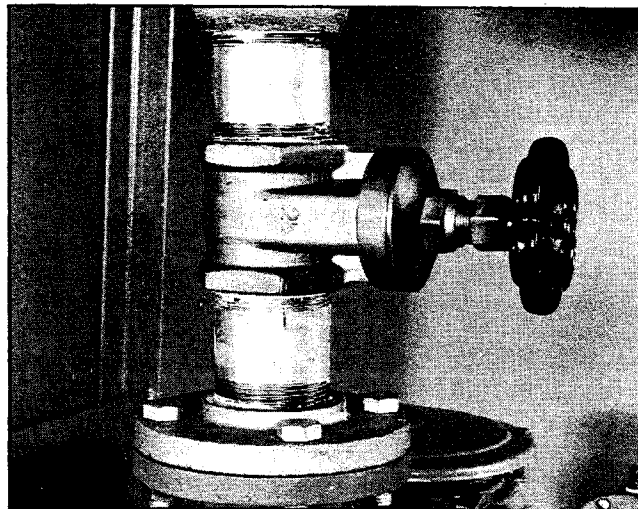

G. Isolating gate valve.

2. Bleed air off at the petcock for the suction gauge. Note the suction pressure; the regulating valves require 6 to 7 PSI to cause them to open and allow the system to purge itself of air.

3. Turn the main disconnect switch "on" and jog the lag pump on and off to double check for proper motor rotation (clockwise as seen from the top).
4. Turn the lead pump "on" and open a few fixtures in the building to create a flow demand.
5. Bleed air from the petcock of the discharge gauge and wait 2 - 3 minutes for the system to purge itself of air and begin pumping. Watch the discharge gauge climb up to your pressure requirement when the system is purged.

ADJUSTMENTS & OPTIONS

HIGH TEMPERATURE SHUTDOWN (STANDARD)

The suction base elbow of the lead pump is fitted with a thermostat relay with an adjustment setting range of 100°F. - 240°F.

This should be set by the factory at 130°F., but you may turn this up as high as 180°F., and not damage any booster components.

The thermostat relay is prewired to the control panel and will shutdown the panel should the thermostat trip at 130°F., and bring the panel back on when the temperature drops approximately 6°F., at its probe. This differential temperature is adjustable.

This thermal shutdown protects the booster components and the consumer from excessive temperatures caused by continued motor operation at a shut off or no flow condition for an extended period of time (over 1/2 hour).

When the lead motor is running its pump at a shut off or no flow condition, most of the motor's horsepower is turned into heat and can quickly be picked up by this thermostat.

NOTE

Keep in mind that whenever the flow demand returns, there will be a delay in bringing the panel on.

LOW SUCTION PRESSURE SHUTDOWN OPTION #7

Option #7 consists of a pressure switch with a double pole single throw relay and is adjustable from 0 - 75 PSI. Copper tubing runs from the pressure switch to the suction manifold. This device is intended to shut the booster down when

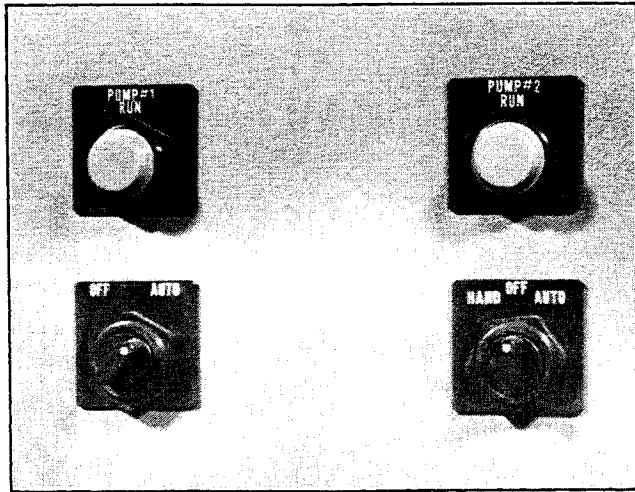

H. Off-Auto Switch for P1, H-O-A Switch for P2.

CAUTION

It may be possible to create too much flow demand for the lead pump to handle alone. If you notice that the system purges itself, but that the discharge gauge didn't climb high enough to reach your requirement, you're probably overloading the lead pump, and you should throttle down your fixtures or turn the lag pump(s) on "auto".

6. It's very possible that you cannot create a high enough flow demand to exceed the capacity of the lead pump and automatically shift the lag pump on. We suggest that you simply turn the lead pump off and turn the lag pump(s) manually (hand) to verify its pumping ability and pressure setting.

NOTE

Should the system fail to purge itself of air within a few minutes, you may bleed the individual brass fittings to the pilot operator on the pressure regulating valves or increase suction pressure to the booster (if possible).

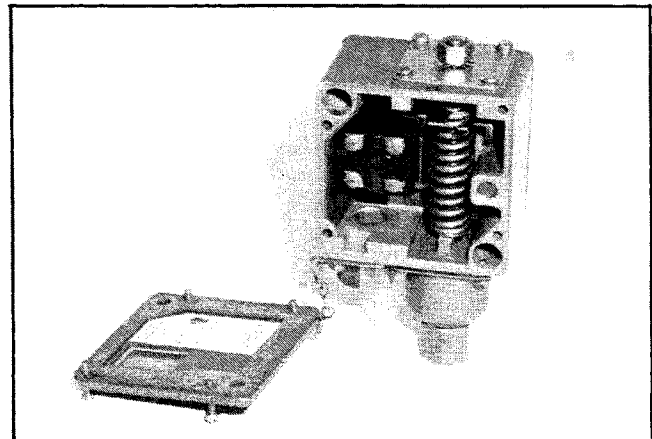

I. Low pressure shutdown switch.

MODEL 752-753

the suction pressure drops extremely low and there is a danger of pulling a vacuum on a city main.

The pressure adjustment has been set at about 20 PSI with the differential (internal adjustment screw) set at about 15 PSI. Subtract 15 PSI from 20 PSI and we get a trip out setting of 5 PSI. This means the booster will shutdown when the suction pressure drops to about 5 PSI and comes back on when the suction pressure comes back up to about 20 PSI. A red warning light on the panel door tells you when this device has shut the system down.

HIGH SUCTION PRESSURE SHUTDOWN, OPTION # 14

Option # 14 consists of a pressure switch with a single pole double throw relay and is adjustable from 0 - 150 PSI. Copper tubing runs from the pressure switch to the suction manifold. This device is intended to shut the booster down when the suction pressure increases enough that the booster is no longer required.

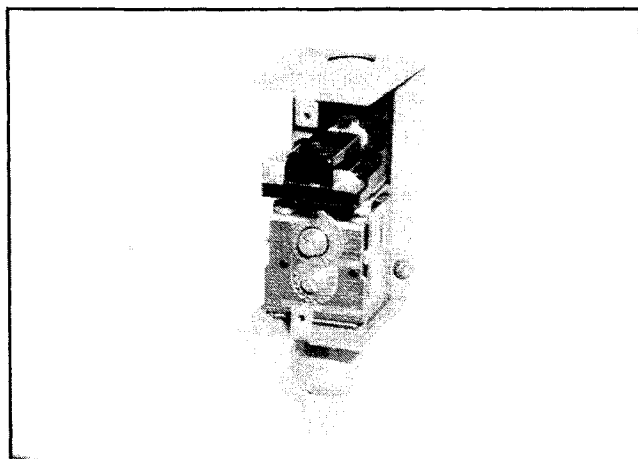

J. High pressure shutdown switch.

The pressure adjustment has been set equal to the system pressure in the discharge manifold and its differential adjustment set at approximately 10 PSI. Once the relay shuts the booster off it will not come back on until the pressure drops 10 PSI in the suction manifold.

NO FLOW Shutdown — Option # 15

This option utilizes a thermostat set to quickly pick up a water temperature increase and shut down the panel. Operation of the lead pump at zero flow will quickly heat up the water to 100°F (adjustable) and trip the thermostat shutting down the booster. Should a small demand return, a pressure switch is connected to the discharge manifold to pick up this immediate drop in system pressure and bring the booster back on. This

pressure switch is set about 10 psi below system pressure but is adjustable.

The pressure switch overrides the thermostat to restore system pressure and then shuts off after a minimum run period of 30 seconds. If as significant amount of water has been used during this time, the thermostat may have cooled down and allow the booster to remain on line to satisfy a light demand.

Should your installation have pressure pulsation problems which cause your pressure switch to cycle on and off, we recommend the addition of a pressure snubber by Allen-Bradley Company, catalog # 836-N7.

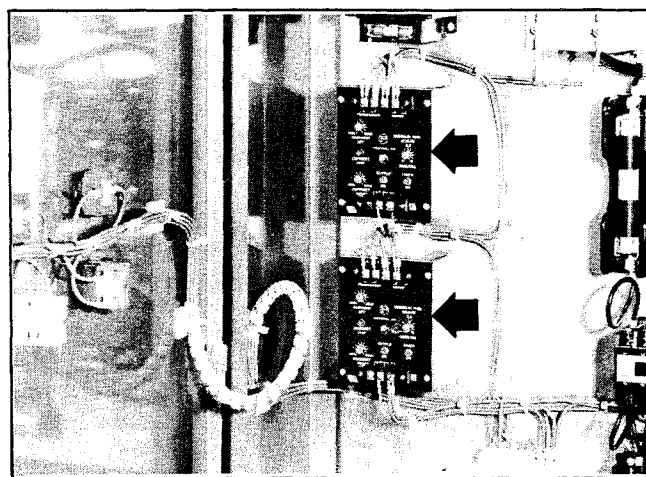

Figure 5. Current Sensing Relays for the Duplex Power Management option

POWER MANAGEMENT OPTION # 10

Option # 10 for a Duplex System consists of one (1) additional current monitor in the control panel for a total of two (2). (See Figure 5). For a triplex system three (3) current monitors are required.

This option is designed to minimize the horsepower "on line" and should only be used when the lead pump is sized smaller than the lag pump. This option cannot be used with options # 8 and # 9 (24 hour clock alternator or lead-lag selector switch).

After the lead pump has been sized smaller than the lag pump, we can take advantage of transitional flow demands. Transitional demand is any flow requirement which exceeds the capacity of the lead pump, but could be handled by the lag pump alone.

Power Management sequences the lead pump off when its capacity is exceeded and starts the lag

MODEL 752-753

pump. The lag pump runs alone until the demand exceeds its capacity and both pumps operate or until the demand drops back down within the range of the lead pump and the lead pump runs alone.

DUPLEX POWER MANAGEMENT SEQUENCE

1CR is the standard current relay on the lead motor which starts the second pump when the capacity of the lead pump is exceeded. 1CR will also shut off the lag pump when it is under loaded and bring the lead pump back on alone for low flows.

2CR will monitor the current drawn by the lag pump and bring the lead pump on in addition to the lag pump. It also shuts off this lead pump when the lag pump alone can handle the flow.

TRIPLEX POWER MANAGEMENT SEQUENCE

1CR is the standard current relay on the lead motor which starts the second pump when the capacity of the lead pump is exceeded.

2CR is part of Option #10 and is sensing the load on the lag motor. Its been adjusted to bring the lead pump back on alone when the load on the lag motor is within the range of the lead motor.

3CR is part of Option #10 and is also sensing the load on the lag motor. Its been adjusted to bring the lead pump on with the lag pump when the capacity of the lag pump is exceeded. A third pump is started if both 1CR and 3CR are fully loaded, and shut off if either relay drops out.

KIT UNIT (OPTION # 11) — FIELD ASSEMBLY INSTRUCTIONS)

1. Assemble the suction manifold assembly to the suction elbows of the base mounted pumps inserting the proper ring gaskets prior to bolting up the mating flanges.
2. Assemble the discharge manifold to the top of the pressure reducing valves of the discharge pipe using the proper ring gaskets between the mating flanges, and afterward making sure that the discharge piping and

manifold weight is carried down to the baseplate through the adjustable V-block supports located near each pump.

3. Position the APCO-PM Booster System in the desired location for hook-up to your suction supply and discharge lines.
4. Assemble pressure gauges to the suction and discharge manifolds (both gauges are identical).
5. Connect prenumbered motor leads from each motor to the same designate terminals in the control box.
6. Connect wires from the thermostats normally closed contacts to the designated terminals in the control panel.
7. WHEN OPTIONS # 7 OR # 14 ARE REQUIRED:

- a. Low Pressure Shutdown (Option # 7)

Connect the copper tubing supply line between the low pressure switch and the tap in the suction manifold. Connect wires from the pressure switch to the panel by following the wiring diagram inside the panel door.

(Refer to wiring diagram.)

- b. High Suction Pressure Shutdown (Option #14)

Connect the copper tubing supply line to the suction manifold.

Connect wires from the normally closed contacts in the pressure switch to terminals # 5 and # 6 in the control box.

(Refer to wiring diagram.)

CONTROL PANEL

Refer to control panel manual, 752C-753C.

PRESSURE REGULATING VALVE

Refer to a PRV Manual by Cla-Val Company.

MODEL 752-753

TROUBLESHOOTING

PROBLEM	SOLUTION
Discharge Pressure too low at discharge gauge	A. Adjust pressure setting screw C.W. on pressure reducing control. B. Lag pump(s) may not be coming on to meet the increased demand. Lower dashpot setting in current relay. C. Bleed off air at discharge gauge petcock. D. Gate valves on discharge side of pump should be fully open.
Discharge Pressure too high at discharge gauge	Adjust pressure setting screw C.C.W. on pressure reducing control.
Lead Motor runs alone - stops - doesn't restart	Press reset button on face of control panel. (Check amperage draw on lead pump to be sure you are not above the motor service factor of 1.15 x full load amps).
Pressure Reducing Valve slams shut noisely when its pump shuts down (check valve feature)	The Pressure Reducing control is adjusted beyond its proper operating range. Adjust pressure setting screw C.C.W. to regain control.
No pumps will run	A. Check electrical connections and fuses. B. Check for mal-adjusted and/or malfunctioning: <ol style="list-style-type: none"> 1. High temperature shutdown switch. 2. High pressure shutdown switch. (Optional) 3. Low pressure shutdown switch. (Optional) C. Open all suction pipe valving.
Cycling Lag pump shifts back to the lead pump and the lead pump shifts back to the lag pump	The PRV's are too far out of balance. Adjust the lag pump PRV pilot screw C.C.W. to reduce its output pressure and bring the pumps into a better operating balance.
Thermostat shuts the system down due to heat build up, but cycles on and off too rapidly	Adjust the thermostat setting up 10° - 20° F. If cycling still occurs, remove the thermostat cover and adjust the differential setting upward from a minimum of 6° F. ΔT to "X4" (24° F. ΔT).

If the above solutions do not solve the problems, contact your local Aurora Pump Sales Office.

REPAIRS

PUMPS

Should the pumps ever need repair or replacement parts, please refer to our instruction manual for our Model "342A" Pumps.

MOTORS

These motors are close coupled JM motors and should be taken to manufacturers authorized

shops for service. Aurora carries an inventory of these motors for quick delivery needs.

CONTROL PANELS

Contact your nearest Aurora Pump representative.

PRESSURE REGULATING VALVES

Contact your nearest Aurora Pump representative.

MODEL 752-753

PARTS

The following list of parts will help you replace certain significant items which are readily available from nationwide distributors:

1. Thermostat — “Penn Controls” # A19ABC-11
2. Low Pressure Switch — “Allen-Bradley” # 836T-T252J
3. High Pressure Switch — “Allen-Bradley” # 836-C7A
4. Press Gauge — “Marsh Instruments” #H-0048

5. Pressure regulating valves replacement parts can be supplied by your local CLA-VAL Company distributor. Refer to the table below for the proper CLA-Valve model number based on the size of the valve.

VALVE SIZE	CLA-VALVE MODEL NUMBER
1-1/4”	91G-01AS
1-1/2”	91G-01AS
2”	91G-01AS
2-1/2”	91G-01AS
3”	91G-01AS
4”	91G-01AB

NOTE

Aurora Pump reserves the right to substitute equivalent control components.



INSTRUCTION MANUAL CONTROLLERS FOR AURORA PUMP APCO BOOSTER SYSTEMS

6

INSTALLATION

1. The controllers are shipped with the pump selector switches and the disconnect switch in the "Off" position. Check to see that during the installation and initial start-up that these devices are in the "Off" position.
2. Check the controller for bolts, nuts, electrical connections that may have loosened or been damaged during shipment.
3. For fusible disconnect controllers the fuse selections are based on the motor full load current values. Class RK-5 dual-element fuses are used, with values of approximately 150% of the full load current of the motor. Replacement fuses should be of the same type and current and voltage rating.
4. Adequate size wiring, based upon the National Electric Code requirements, is to be connected to the top of the disconnect switch. Check the incoming branch circuit wiring for the line frequency and voltage, and that these agree with the voltage and frequency of the controller.

START-UP

1. With the disconnect switch in the "Off" position, energize the incoming power to the controller. Measure the line voltage at the top of the disconnect switch, the voltage readings should be the same between all three phase lines, and agree with the voltage rating of the controller.
2. Close and secure the enclosure door, tightening the door hold-down screws securely. With the pump selector switches in the "Off" position, move the disconnect handle to the "On" position.
3. To check the pump motor rotation, remove the drip cover of the lead pump motor. Jog the lead pump by momentarily turning the Pump 1 selector switch to the "Auto" position, or the "Hand" position if options 8 or 9 are provided. Return the Pump 1 selector to the "Off" position, and note the pump rotation. If the rotation is not correct (clockwise as seen from the top of the motor), return the disconnect switch handle to the "Off" position, de-energize the incoming branch circuit power, open the enclosure door and measure the voltage at the top of the disconnect switch to verify that the incoming power is off. After verifying that the incoming circuit is off, interchange any two of the three lines at the top of the disconnect switch to reverse the pump rotation. Close the enclosure door, energize the incoming branch circuit power, move the disconnect handle to the "On" position, and repeat the above instructions to verify the correct pump rotation. Replace the drip cover of the lead pump motor after the correct pump rotation is verified.
4. With the incoming power energized, and pump rotation verified, the controller is ready for the initial start-up operation. The current sensing devices, overload elements, etc. have been selected, installed, and adjusted at the factory for the correct motor and pump loads, and flow levels. Re-adjustment or changes in the field should not be necessary. Changing the pressure regulating valve settings may require a change in the current settings of the current sensing devices, changes in the settings of pressure regulating valves should not be made without consulting a representative of the Aurora Pump Company.
5. Manual Operation — The lead pump will run manually by turning the selector switch to the "Auto" position, or the "Hand" position if options 8 or 9 have been provided. The lag pump/pumps will run manually by turning the selector switches to the "Hand" position. Do not run the lead pump and the lag pumps simultaneously in the "Hand" or manual operation without adequate flow through the system.
6. Automatic Operation — The system is set for automatic operation when all of the selector switches are set in the "Auto" position.

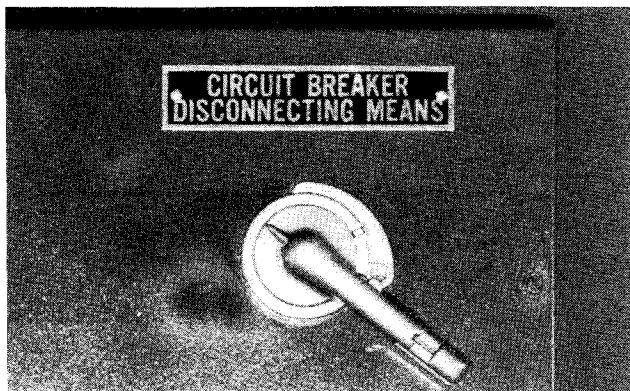

Figure 1

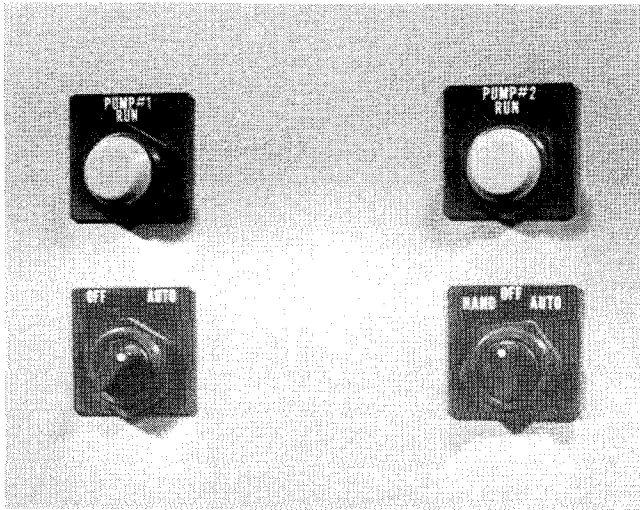

Figure 2

7. **CAUTION** — During the initial energizing of the controller, before moving the disconnect handle to the "On" position, set all of the pump selector switches to their "Off" positions. After energizing the controller by moving the disconnect handle to the "On" position, the pump selector switches may be set for automatic operation, always turn the lead pump selector switch to the "Auto" position first.

OPERATION — DUPLEX CONTROLLERS Standard Current Sensing System

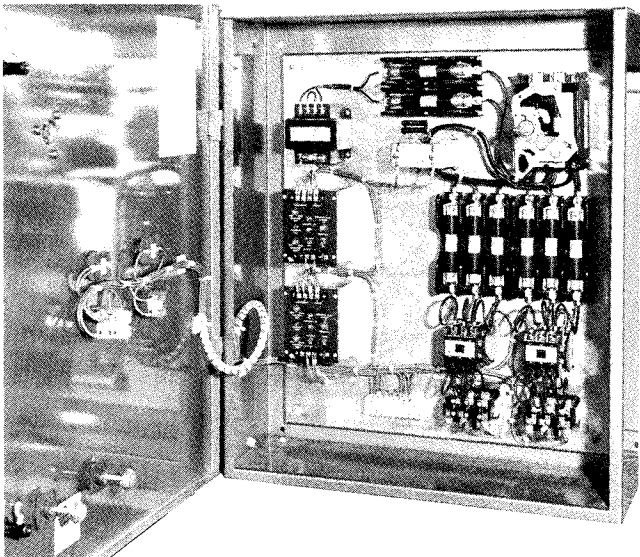

Figure 3

The lead pump will run continuously, unless the high water temperature switch has tripped, or an overload has occurred on the lead pump motor. Also, options 7, 7A, 14 & 15 are shut-down options, and may stop the lead pump operation. If options 8, 9, or 10 have been supplied, refer to the operation description for these options. Refer also to the system descriptions of these options in the Aurora Pump instruction manual 752-753.

The pump motor overload relay must be manually reset if an overload has occurred, using the "Reset" buttons on the cover of the enclosure.

The high water temperature switch is an automatic reset device, and pump operation will resume when this switch resets after enough flow occurs to cool the water that has been heated. When the high water temperature switch is tripped, both the lead and lag pumps will be inoperative in both the manual and automatic operations until the temperature lowers, automatically resetting the high water temperature switch.

CAUTION — In automatic operation, the lag pump will run in place of the lead pump if the lead pump overload has tripped.

With the lead pump running continuously, the lag pump will run if the lead pump cannot handle the system flow requirements. This is sensed by the current sensing devices. If the current of the pump motor rises to the current trip setting, an output contact will close and energize the lag pump starter and motor. The lag pump will continue to run for a minimum run timing period, and then stop if the flow requirements have dropped to a level that the lead pump can fulfill alone. For adjustment instructions of the current sensing devices, refer to the current sensing device adjustment section.

OPTION 1 — Enclosures — The standard enclosure supplied is Nema 1, General Purpose. If option 1 is supplied, this indicates a more specialized enclosure is used. These enclosures are as follows:

- STANDARD Nema 1 — General Purpose
- OPTIONAL Nema 3R — Rainproof and Sleet (Ice) Resistant
- OPTIONAL Nema 4 — Watertight and Dust-Tight
- OPTIONAL Nema 12 — Dust-Tight and Driptight

OPTION 2 — "Power On" Pilot Light — The "Power On" pilot light is added on the cover of the enclosure and wired to the control transformer secondary. When the light is on, this gives a visual indication that the system power is available, the disconnect switch is "On", and that the control transformer supplying power to the pump starters is functioning.

OPTION 3 — Running Period Timer for Each Pump — The elapsed time meters, or running period timers, are mounted in the cover of the enclosure for visual reading of the amount of time each pump has operated. Each timer is energized when the pump starter is energized. The time readings are five digit readings, giving an indication of up to 100,000 hours.

OPTION 6 — Circuit Breakers Instead of Fuse Clips — Circuit breaker short circuit protection may be desired rather than the standard fuse type of protection for the motor circuits. A 3-Pole circuit breaker is used in place of the (3) fuses for each motor. The circuit breakers are not supplied with external operating handles, the main disconnect switch is still used for de-energizing the incoming power to the controller.

OPTION 7 — Low Suction Pressure Shut-Down with Visual Indication — A low suction pressure switch is used to indicate to the controller control circuit to shut-down the system in the event of low pressure in the incoming water supply. A normally open contact that closes when suction pressure is adequate opens when the pressure drops too low. The opposite contact of the pressure

switch closes when the pressure is low, and the "Low Suction Pressure" pilot light is energized. The pilot light is mounted on the cover of the enclosure. When pressure rises, the pilot light will go out, and the system operation will resume automatically.

OPTION 7A — Low Suction Pressure Shut-Down With Visual Indication, Alarm Bell, and "Silence Alarm" Push Button — In addition to the low suction pressure shut-down and pilot light indication described in option 7, an alarm bell is mounted in the cover of the enclosure. The alarm bell may be silenced by pushing the "Silence Alarm" push button on the enclosure door. The alarm will automatically reset when the low suction pressure condition is improved and the system operation has resumed automatically.

OPTION 8 — 24-Hour Time Clock Alternator — A 24-hour time clock alternator is added to interchange the operation of the lead and lag pumps, allowing the pumps to share time as the lead pump. To do this both the pumps should be sized for the same flow capabilities. At the end of the 24-hour timing period, the lead pump becomes the lag pump, etc. The operation of the system is the same as for the standard current sensing system, except the lead pump will be determined by the time clock alternation.

This option cannot be used with options 9 or 10, and requires that the selector switches for both pumps be "Hand-Off-Auto" and *that the pumps be sized identically*. For adjustment instructions, refer to the current sensing adjustment section for Option 8.

OPTION 9 — "Lead-Lag" Selector Switch — A "Lead-Lag" selector switch is added to interchange the operation of the pumps, allowing the pumps to share time as the lead pump. The selection of the lead pump is manual, by turning the selector the lead pump becomes the lag pump, etc. *The pumps must be sized identically to use option 9*. The operation of the system is the same as for the standard current sensing system, except the lead pump will be determined by the setting of the "Lead-Lag" selector switch.

The option cannot be used with options 8 or 10, and requires that the selector switches for both pumps be "Hand-Off-Auto". For adjustment instructions, refer to the current sensing adjustment section for option 9.

OPTION 10 — Power Management — The purpose of the Power Management system is to allow a smaller lead pump to be used during periods of light demand, thus saving electrical energy. The lead pump is sized smaller than the lag pump, and during these light demand periods less horsepower is used, less electrical energy, and thus Power Management. For some system flow requirements this option can provide the equivalent of a triplex system using only two pumps.

**Power Management
Option 10**

Light Demand	Medium Demand	Full Demand
Pump 1 Alone	Pump 2 Alone	Both Pump 1 & Pump 2

On a standard system, the lead pump runs continuously, and the lag pump runs also on increased demand. With the Power Management system, the lead pump runs during light demand periods, the lag pump runs alone during medium demand periods, and both pumps run during the peak demand periods. This option cannot be used with options 8 or 9. For adjustment instructions, refer to the current monitoring adjustment section for option 10.

The system operation is similar to the standard current sensing system, but with additional current monitoring. When the lead pump demand rises to the current trip level, the contact closure energizes the lag pump starter, and de-energizes the lead pump starter. A second current monitor indicates if the lag pump alone cannot handle the system demand, and re-energizes the lead pump starter so that both pumps are running.

As the currents drop with lowered demand, pump 2 will run alone with a medium demand, and pump 1 will run alone with the light demand flow.

As on the standard current sensing system, should the lead pump overload relay trip, the lag pump will run in place of the lead pump in automatic operation.

OPTION 14 — High Pressure Shut-Down — A pressure switch is added to the system to indicate to the controller that a high suction pressure has been attained, and will shut-down the pumps. This is usually an indication of a very light system demand, and is not normally an alarm condition. The system will reset automatically when suction pressure drops, and the pumps will resume operation.

OPTION 15 — No-Flow Shut-Down — A pressure switch is added to the system in parallel with the high water temperature switch/switches. Should a no-flow condition exist, both the water temperature and the pressure in the system will rise after a short period of time. With the high water temperature switch tripped, and the system pressure switch tripped, the system will shut-down. When flow resumes, the pressure switch contact will re-close, starting the lead pump. With water flow through the system, the water temperature will lower, resetting the temperature switch. A minimum run timer is used with the no-flow shut-down option, to prevent cycling.

OPTION 16 — Lead Pump Failure Alarm — With the system set for automatic operation, and all inputs call for the lead pump to run, if the overload relays have tripped and the pump doesn't run, an alarm pilot light indication of "Lead Pump Failure" will come on in the door of the panel, and two contacts are provided for remote alarm wiring.

OPTION 16 CANNOT BE USED WITH OPTION 10 — DUPLEX POWER MANAGEMENT

Option 16 becomes Option 16A for the following alternation options:

- DUPLEX — Option 8 — Time Clock Alternation
- Option 9 — Lead-Lag Selector Switch

OPERATION — TRIPLEX CONTROLLERS

Standard Current-Sensing System

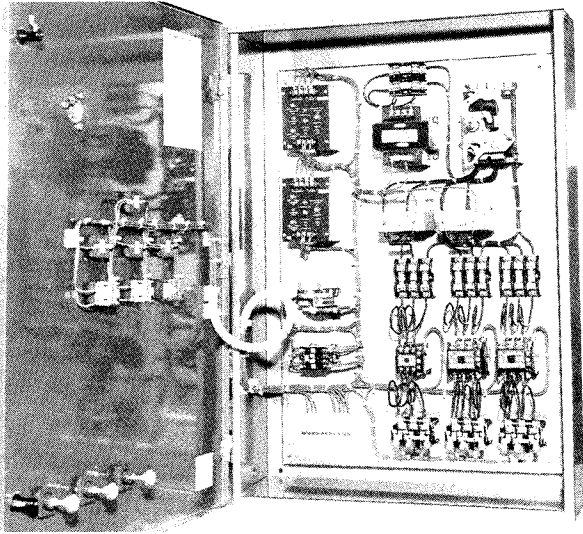

Figure 4

The lead pump will run continuously, unless the high water temperature switch has tripped, or an overload has occurred on the lead pump motor, and the motor overload has tripped. Also, options 7, 7A, 14 & 15 are shut-down options, and may stop the lead pump operation. Refer to the descriptions of these options in the Aurora Pump instruction manual 752-753. If Options 8, 8A, 9, 9A, or 10 have been supplied, refer to the operation description for these options also.

The pump motor overload relays must be manually reset if an overload has occurred, using the "Reset" buttons on the cover of the enclosure.

The high water temperature switch is an automatic reset device, and pump operation will resume when this switch resets after enough flow occurs to cool the water that is overheated. When the high water temperature switch is tripped, the lead and lag pumps will be inoperative in both the manual and automatic operations until the temperature lowers, and resets the switch.

CAUTION — In automatic operation, the lag pump will run in place of the lead pump if the lead pump overload relay has tripped on overload.

With the lead pump running continuously, the first lag pump will run if the lead pump cannot handle the system flow requirements. This is sensed by the current sensing device monitoring the pump motors. If the current of the pump motor rises to the current trip setting, an output contact will close to energize the first lag pump starter and motor. The first lag pump will continue to run for a minimum run timing period, and then stop if the flow requirements have dropped to a level that the lead pump can fulfill alone.

With both the lead pump and the first lag pump running, and the demand flow is not satisfied, a second current sensing device closes a contact to energize the second lag pump starter and motor. The second lag pump will continue to run for a minimum run timing period, and then stop if the flow requirements have dropped to a level that the lead

and first lag pump can fulfill alone. For adjustment instructions of the current sensing, refer to the triplex current sensing adjustment section.

OPTION 1 — Enclosures — The standard enclosure supplied is Nema 1, General Purpose. If option 1 is supplied, this indicates a more specialized enclosure is used. These enclosures are as follows:

Standard Nema 1 — General Purpose

Optional Nema 3R — Rainproof and Sleet (Ice) Resistant

Optional Nema 4 — Watertight and Dust-Tight

Optional Nema 12 — Dust-Tight and Driptight

OPTION 2 — "Power On" Pilot Light — The "Power On" pilot light is added on the cover of the enclosure and wired to the control transformer secondary. When the light is on, this gives a visual indication that the system power is available, the disconnect switch is "On", and that the control transformer supplying power to the pump starters is functioning.

OPTION 3 — Running Period Timer for Each Pump — The elapsed time meters, or running period timers, are mounted in the cover of the enclosure for visual reading of the amount of time each pump has operated. Each timer is energized when the pump starter is energized. The time readings are five digit readings, giving an indication of up to 100,000 hours.

OPTION 6 — Circuit Breakers Instead of Fuse Clips — Circuit breaker short circuit protection may be desired rather than the standard fuse type of protection for the motor circuits. A 3-Pole circuit breaker is used in place of the (3) fuses for each motor. The circuit breakers are not supplied with external operating handles, the main disconnect switch is still used for de-energizing the incoming power to the controller.

OPTION 7 — Low Suction Pressure Shut-Down with Visual Indication — A low suction pressure switch is used to indicate to the controller control circuit to shut-down the system in the event of low pressure in the incoming water supply. A normally open contact that closes when suction pressure is adequate opens when the pressure drops too low. The opposite contact of the pressure switch closes when the pressure is low, and the "Low Suction Pressure" pilot light is energized. The pilot light is mounted on the cover of the enclosure. When pressure rises, the pilot light will go out, and the system operation will resume automatically.

OPTION 7A — Low Suction Pressure Shut-Down With Visual Indication, Alarm Bell, and "Silence Alarm" Push Button — In addition to the low suction pressure shut-down and pilot light indication described in Option 7, an alarm bell is mounted in the cover of the enclosure. The alarm bell may be silenced by pushing the "Silence Alarm" push button on the enclosure door. The alarm will automatically reset when the low suction pressure condition is improved and the system operation has resumed automatically.

OPTION 8 — 24-Hour Time Clock Alternator — Pumps 2 & 3 — A 24-hour time clock alternator is added to interchange the operation of the first and second lag pumps, allowing these two pumps to share time. At the

end of the 24-hour timing period the first lag pump becomes the second, the second lag pump becomes the first, etc. This is used when a small lead pump is desired for periods of very light flow, and the lag pumps are used heavily during the normal flow periods. The operation of the system is the same as the standard current sensing system for triplex controllers, except the first and second lag pumps will be determined by the time clock alternation. This option requires that the pumps 2 & 3 be sized identically.

This option cannot be used with options 8A, 9, 9A, or 10. If the lead pump is shut-down by overload, the first lag pump, as determined by the time clock alternator, will run in place of the lead pump. For adjustment instructions, refer to the current monitoring adjustment section for Option 8, triplex.

OPTION 8A — 24-Hour Time Clock Alternator — Pumps 1 & 2 — A 24-hour time clock alternator is added to interchange the operation of the pumps 1 & 2 as the lead pump, allowing these pumps to share time as the lead pump. At the end of the 24-hour timing period the second pump becomes the lead pump, and the first pump becomes the first lag pump. This is used when pumps 1 & 2 are sized equally, and the system flow is fairly constant during periods of light demand. The operation of the system is the same as the standard current sensing system for triplex controllers, except the lead and first lag pump will be determined by the time clock alternation. This option requires that pumps 1 & 2 be sized identically.

This option cannot be used with options 8, 9, 9A, or 10. If the lead pump is shut-down by overload, the first lag pump, as determined by the time clock alternator, will run in place of the lead pump. For adjustment instructions, refer to the triplex current monitoring adjustment section for option 8A.

OPTION 9 — “Lead-Lag” Selector Switch — Pumps 2 & 3 — A “Lead-Lag” selector switch is added to interchange the operation of the first and second lag pumps, allowing these two pumps to share time. The selection of the first lag pump is manual, by turning the selector the first lag pump becomes the second lag pump, etc. This system is used when a small lead pump is desired for periods of very light flow, and the lag pumps are used heavily during the normal flow periods. The operation of the system will be determined by the setting of the selector switch. This option requires that pumps 2 & 3 be sized identically.

This option cannot be used with options 8, 8A, 9A, or 10. If the lead pump is shut-down by overload, the first lag pump, as determined by the selector switch, will run in place of the lead pump. For adjustment instructions, refer to the triplex current adjustment section for option 9.

OPTION 9A — “Lead-Lag” Selector Switch — Pumps 1 & 2 — A “Lead-Lag” selector switch is added to interchange the operation of the pumps 1 & 2 as the lead pump, allowing these pumps to share time as the lead pump. At the selection of the “Lead-Lag” selector switch, either pump 1 or 2 becomes the lead pump. The selection of the lead pump is manual. This system is used when pumps 1 & 2 are sized equally, and the system flow is fairly constant during periods of light demand. The operation of the sys-

tem is the same as the standard current sensing system for triplex controllers, except the lead and first lag pump will be determined by the “Lead-Lag” selector switch. This option requires that Pumps 1 & 2 be sized identically.

This option cannot be used with options 8, 8A, 9 or 10. If the lead pump, as determined by the “Lead-Lag” selector switch, is shut down by overload, the first lag pump will run in place of the lead pump. For adjustment instructions, refer to the triplex current adjustment section for Option 9A.

OPTION 10 — Power Management — The purpose of the Power Management system is to allow a smaller lead pump to be used during periods of light demand, thus saving electrical energy. The lead pump is sized smaller than the lag pumps, and during these light demand periods less horsepower is used, less electrical energy, and thus Power Management. This option can provide the equivalent of a quadruplex system using only three pumps. On a standard system the lead pump runs continuously, and the lag pumps run also on increased demand. With the Power Management system, the lead pump runs during light demand periods, the first lag pump runs alone for the next demand level, both the lead and first lag pumps run together for the next higher demand level, and for the maximum demand level the second lag pump is also added to the system.

As on the standard current sensing system for a triplex, should the lead pump overload relay trip, the first lag pump will run in place of the lead pump in automatic operation.

This option cannot be used with options 8, 8A, 9, or 9A. For adjustment instructions, refer to the current monitoring adjustment section for triplex systems, Option 10.

OPTION 14 — High Pressure Shut-Down — A pressure switch is added to the system to indicate to the controller that a high suction pressure has been attained, and will shut-down the pumps. This is usually an indication of a very light system demand, and is not normally an alarm condition. The system will reset automatically when suction pressure drops, and the pumps will resume operation.

OPTION 15 — No-Flow Shut-Down — A pressure switch is added to the system in parallel with the high water temperature switch/switches. Should a no-flow condition exist, both the water temperature and the pressure in the system will rise after a short period of time. With the high water temperature switch tripped, and the system pressure switch tripped, the system will shut down. When flow resumes, the pressure switch contact will re-close, starting the lead pump. With water flow through the system, the water temperature will lower, resetting the temperature switch. A minimum run timer is used with the no-flow shut-down option to prevent cycling.

OPTION 16 — Lead Pump Failure Alarm — With the system set for automatic operation, and all inputs call for the lead pump to run, if the overload relays have tripped and the pump doesn't run, an alarm pilot light indication of “Lead Pump Failure” will come on in the door of the panel, and two contacts are provided for remote alarm wiring.

OPTION 16 CANNOT BE USED WITH OPTION 10 — TRIPLEX POWER MANAGEMENT.

Option 16 becomes Option 16A for the following alternating options:

- TRIPLEX — Option 8A — Time Clock Alternation — Pumps 1 & 2
- Option 9A — Lead-Lag Selector Switch — Pumps 1 & 2

CURRENT MONITORING

Firetrol FTA-430 Current Monitor

The Firetrol FTA-430 is a solid-state unit designed for use with the Aurora APCO Booster Systems, and incorporates two current trip points and one minimum run timer in each unit. Using two current trip points allows for precise adjustment of a system flow differential. A current transformer input is used, thus FTA-430 is specifically monitoring current flow to the pump motors.

The current monitor unit has four adjustments; however, only one adjustment is recommended in the field, the other adjustments are made at the factory prior to shipment of the booster system. Refer to Figure 5 showing a panel layout of the current monitor.

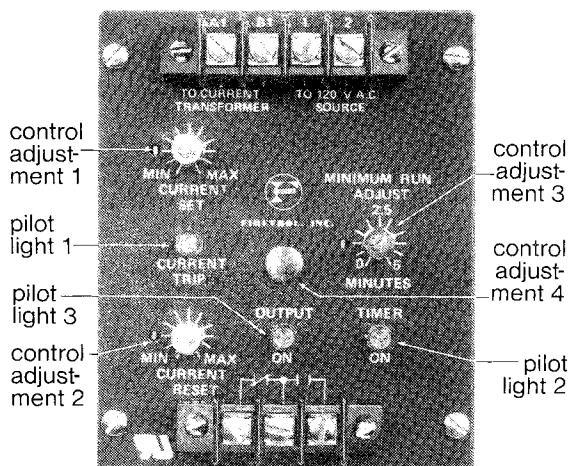

Figure 5

Adjustments 1 & 2 are made at the factory, the currents at which the output contacts will close to bring in additional pumps, or open to shut-off the additional pumps. These current trip settings are made at the factory to measure the point at which the system flow indicates the need for additional or fewer pumps. It is not recommended that these current adjustments be changed in the field without consulting the factory, since the original current settings have been made with calibrated flow equipment, and specific settings of the pressure regulating valves on the outputs of the pumps. A change in the setting of the pressure regulating valve may cause the setting of the current trip points to change, and neither the pressure regulating valve settings or the current monitoring trip settings should be changed without consulting an Aurora Pump representative.

Adjustment 1 — Current Set — is the current at which the current monitor output contact will close to bring in an additional pump as the flow increases.

Adjustment 2 — Current Reset — is the current at which the current monitor will re-open the output contact to drop out the additional pump as flow decreases.

The FTA-430 has five standard current ranges. The range selected for a system will vary with the sizes of the motors and the voltages of the system. The ranges are as follows:

Catalog Number	Range (Minimum/Maximum In Amps)	Potentiometer Adjustment Per Increment In Amps
FTA-430-A	5 A/15 A	1 A
FTA-430-B	5 A/20 A	1-½ A
FTA-430-C	10 A/30 A	2 A
FTA-430-D	15 A/35 A	2 A
FTA-430-E	20 A/50 A	3 A
FTA-430-X	Special Range	

Adjustment 3 is made at the factory, the minimum run timing adjustment is set for 30 seconds; however, the timing may be adjusted in the field from 10 seconds to 5 minutes by turning the “Minimum Run Adjustment” potentiometer.

The calibration of the minimum run timing adjustment is only an approximate indication, it is recommended that after an adjustment is made in the field, the timing be verified with a watch or other timing device. The calibrations are 0, 2.5, and 5 minutes for minimum, midscale, and maximum settings.

Adjustment 4 is made at the factory, the current monitor output is delayed for a period of approximately 3 seconds to allow the pump motor current inrush to drop back to a running current level after the pump start has occurred. Field adjustment is not recommended.

Once adjustments 1, 2, and 3 have been made at the factory, the settings are locked in place by tightening the hex locking bushings on the potentiometer shafts.

There are three pilot lights on each current monitor, as follows:

1. “Current Trip” — Indicates when the current being monitored is above the set or reset trip settings.
2. “Timer On” — Indicates when the minimum run timing is occurring. If the current monitor indicates that the current has risen above the trip point, the output will be energized after approximately a 3 second delay. It will remain energized for the period of the minimum run adjust setting, keeping the output on even though the current may fall during this period.
3. “Output On” — Indicates when the output of the current monitor is energized, calling for additional pump capacity.

ADJUSTMENT INSTRUCTIONS

The current monitors sense when the pump motor currents have reached values that indicate a system flow change-over point, and the output of the current monitor will then control the sequence of operations for the pumps.

Field adjustment of the current monitors is not recommended unless adequate flow test equipment is available, and the flows can be adjusted to the specific change-over

levels. However, approximate adjustments can be made in the field if necessary.

The pump motors are sized to drive the pumps at approximately the maximum pump flow when the motor current is close to, or slightly less than, the full load current of the motor. Thus, a motor operating at 90-100% of the full load current is an approximate indication that additional pumps may be required to satisfy the system flow.

When the pump flow is reduced, the motor current is reduced, and when the motor current drops to 70-75% of the full load current, this is an indication that a much lower flow is required, and additional pumps are not needed to maintain the lower flow.

Each current monitor has a current range that has been selected with the motor currents and voltages of a specific system, the current trip settings show a minimum, maximum setting, with calibration points of 10% of the maximum range shown on the current monitor. Thus, for example, the 10 to 30 amp range current monitor would have a 20 amp total adjustment, with each calibration point equal to approximately 2 amps.

To set the current monitors it is important to obtain the full load currents from the motor nameplates for the correct voltage of the system, and compare this value with the approximate full load currents shown in table 1.

TABLE 1

Horsepower	Approximate Motor Full Load Currents — 60 Hz. Full-Load Amperes		
	200/208v.	230/240v.	460/480v.
1½	4.6 A.	4.0 A.	2.0 A.
2	5.8	5.4	2.7
3	8.6	7.6	3.8
5	14.0	14.0	7.0
7½	20.0	18.0	9.0
10	27.5	26.0	13.0
15	40.0	39.0	19.5
20	N.A.	48.0	24.0

Refer to table 2 for adjustment of duplex controllers, and table 3 for triplex controllers. Also, some booster options may have slightly different current adjustment instructions, refer to the adjustment instructions that match the system options.

With the power de-energized to the controller, open the controller door and note the range of the current monitors. Turn all the "Current Set" and the "Current Reset" potentiometers for all the current monitors used to their full clockwise position. To set the potentiometers, move the adjusting shaft counter-clockwise as closely as possible to the position of current calibration indicated in the adjustment instructions that follow, for the option used. With these adjustments the system should perform close to the flow change-over points; however, slight additional adjustments may be necessary during the initial running of the system.

After field adjustments, with the system performing satisfactorily, lock the adjustment potentiometers by carefully tightening the hex locking nuts on the potentiometers.

TABLE 2

Duplex — Current Adjustments

CONTROLLER TYPE	CURRENT MONITOR 1CR		CURRENT MONITOR 2CR	
	CURRENT SET	CURRENT RESET	CURRENT SET	CURRENT RESET
STANDARD CURRENT SENSING	Multiply Pump 1 Amps	Add Pump 1 and Pump 2 Amps	2CR Not Req'd.	2CR Not Req'd.
OPTION 8	by .90	Multiply by .75		
OPTION 9				
OPTION 10 POWER MANAGEMENT	Multiply Pump 1 Amps by .90	Multiply Pump 2 Amps by .75	Multiply Pump 2 Amps by .90	Add Pump 1 and Pump 2 Amps Multiply by .75

Note: Amps above are the full-load currents of the pump motors.

TABLE 3

Triplex — Current — Adjustments

CONTROLLER TYPE	CURRENT MONITOR 1CR		CURRENT MONITOR 2CR		CURRENT MONITOR 3CR	
	CURRENT SET	CURRENT RESET	CURRENT SET	CURRENT RESET	CURRENT SET	CURRENT RESET
STANDARD CURRENT SENSING OPTION 8A OPTION 9A	Multiply Pump 1 Amps by .90	Multiply Pump 1 Amps by .75	Multiply Pump 2 Amps by .90	Multiply Pump 2 Amps by .75	3CR Not Req'd.	3CR Not Req'd.
OPTION 8 OPTION 9	Multiply Pump 1 Amps by .90	Multiply Pump 1 Amps by .75	Multiply Pump 2 Amps by .90	Add Pump 2 and Pump 3 Amps Multiply by .75	3CR Not Req'd.	3CR Not Req'd.
OPTION 10 POWER MANAGEMENT	Multiply Pump 1 Amps by .90	Multiply Pump 2 Amps by .75	Multiply Pump 2 Amps by .80	Add Pumps 1 and 2 Multiply by .75	Add Pumps 1 and 2 Multiply by .90	Add Pumps 1, 2 and 3 Multiply by .75

Note: Amps above are the full-load currents of the pump motors.



AURORA SERIES 750 & 760

SELECTION CHART

1750 R.P.M.

ENCLOSED IMPELLER

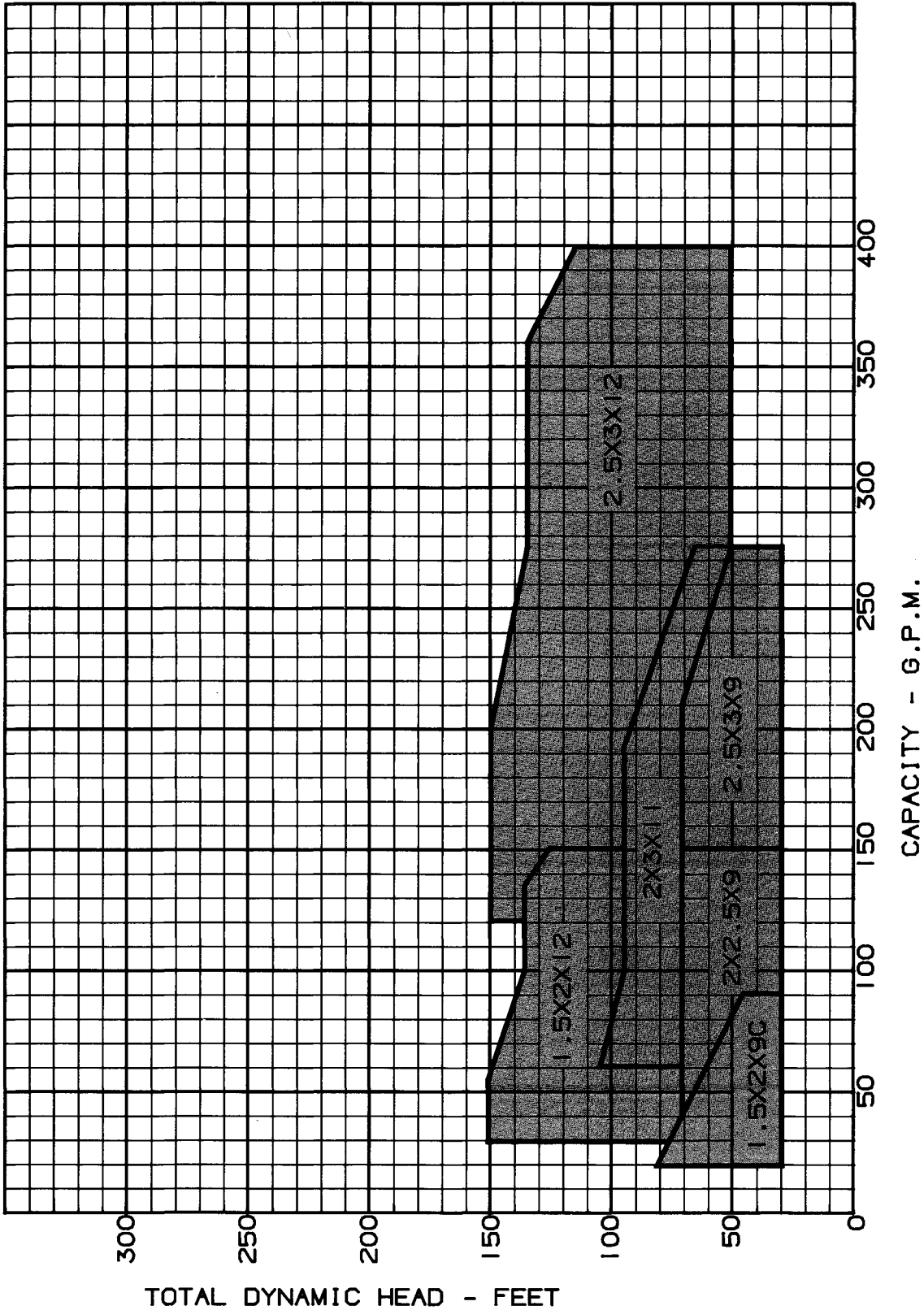

SELECTION CHART

DATED **SEPTEMBER 1987**

3500 R.P.M.

ENCLOSED IMPELLER

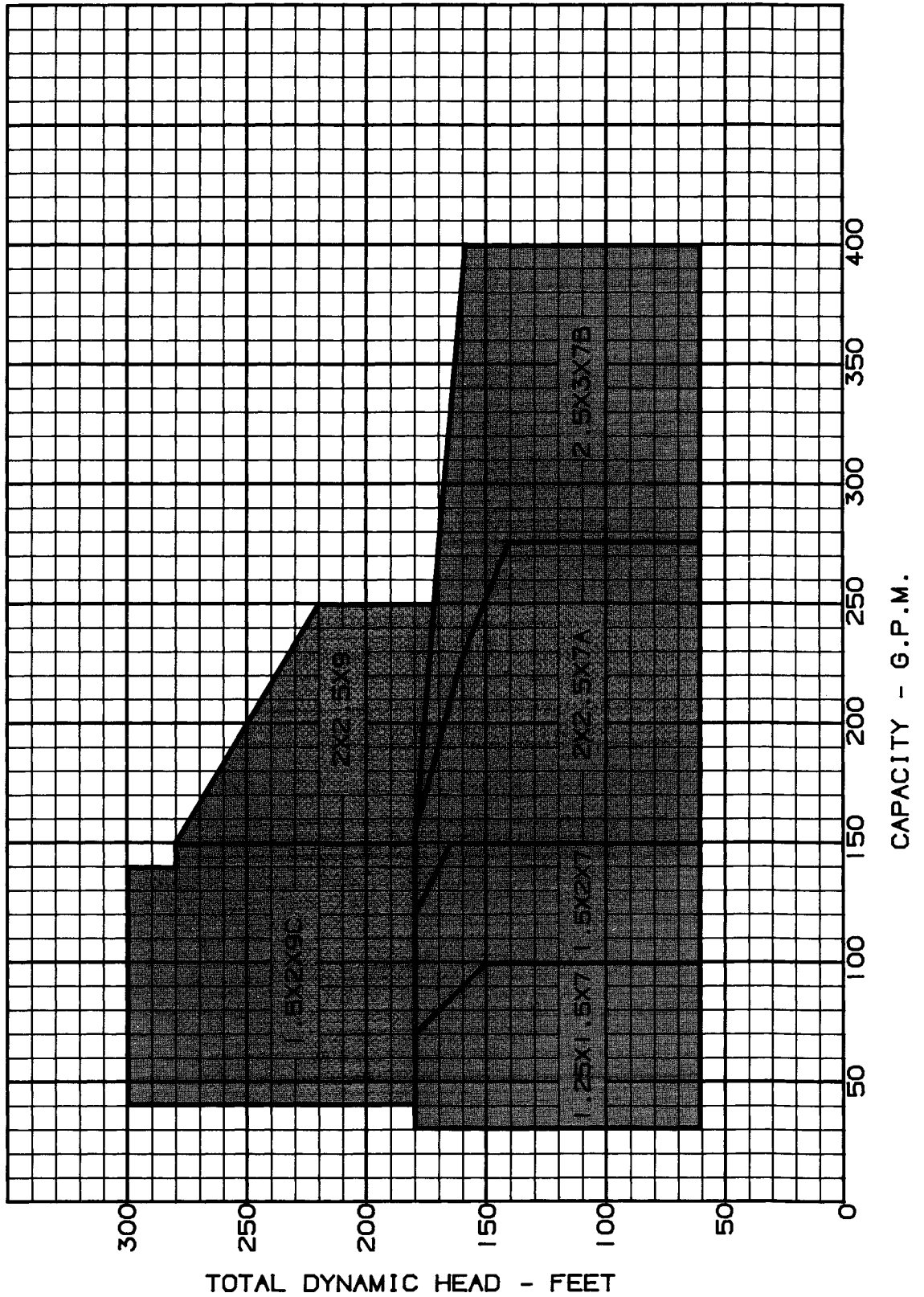

Performance Curves for the 750/760 Series

MODEL/SIZE	R.P.M.	CATALOG PAGE	PDF PAGE
1-1/4 x 1-1/2 x 7	3500	401	2
1-1/2 x 2 x 7	3500	401	2
2 x 2-1/2 x 7A	3500	402	3
2-1/2 x 3 x 7B	3500	402	3
1-1/2 x 2 x 9C	3500/1750	403	4
2 x 2-1/2 x 9	3500/1750	404	5
2-1/2 x 3 x 9	1750	405	6
2 x 3 x 11	1750	406	7
1-1/2 x 2 x 12	1750	407	8
2-1/2 x 3 x 12	1750	407	8

SERIES 750 / 760 ENCLOSED IMPELLER

1 1/4 x 1 1/2 x 7

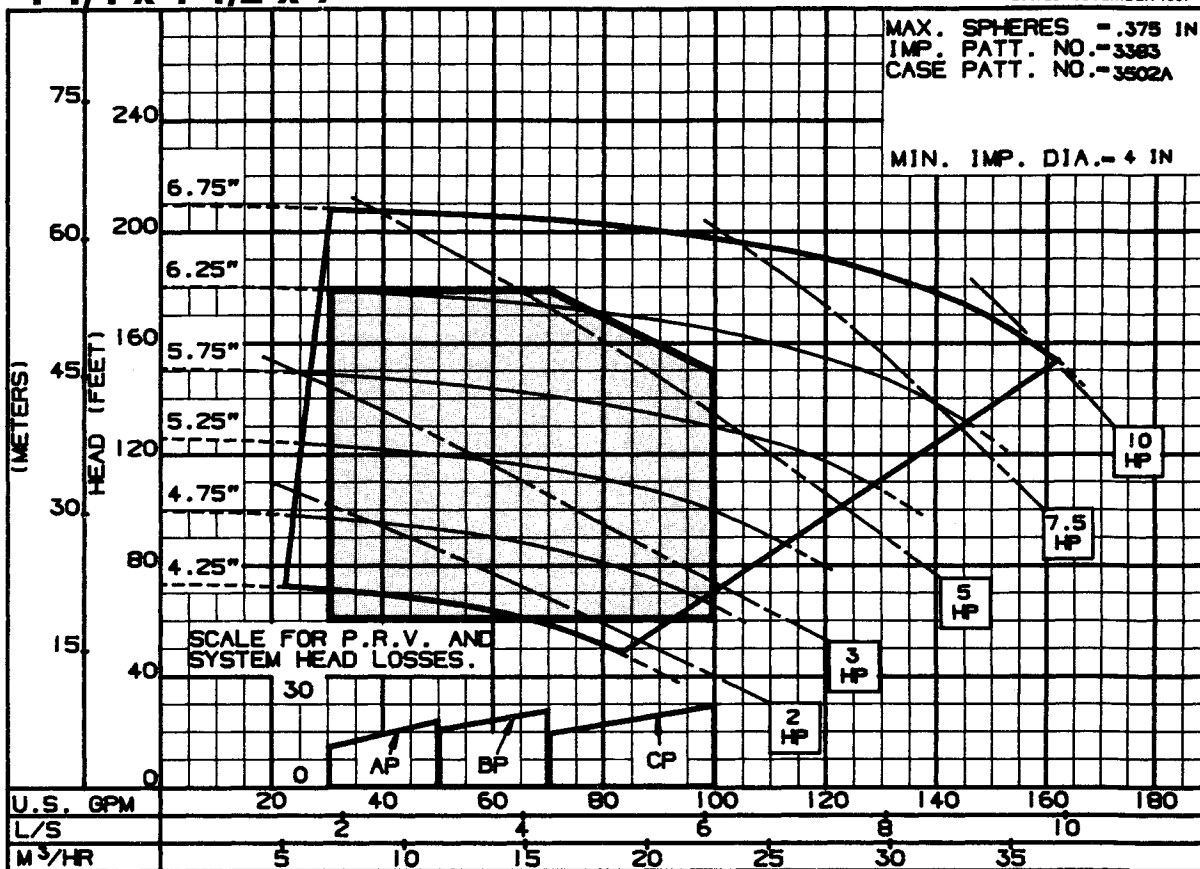

3PC-144227A

1 1/2 x 2 x 7

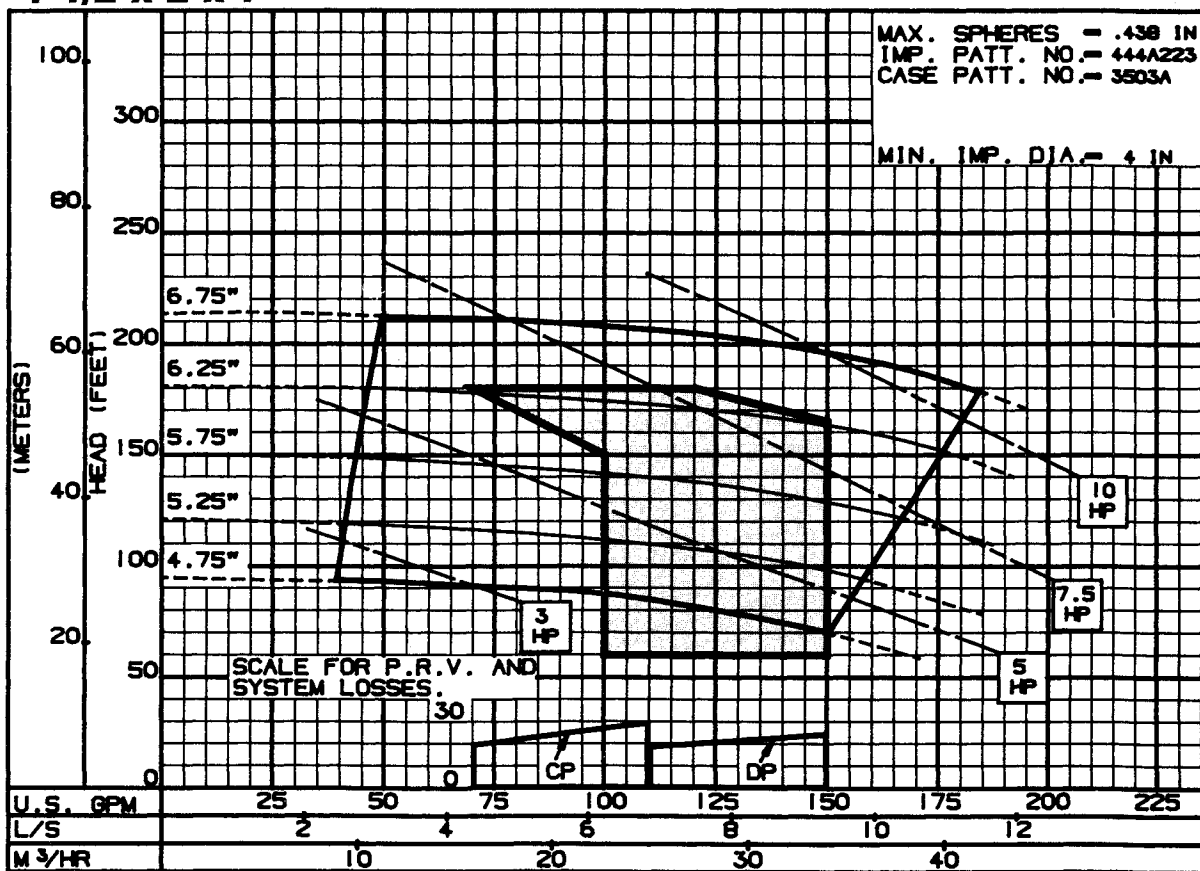

3PC-144228A

ap AURORA®

PENTAIR PUMP GROUP

SERIES 750 / 760 ENCLOSED IMPELLER

2 x 2 1/2 x 7A

**3500
R.P.M.**

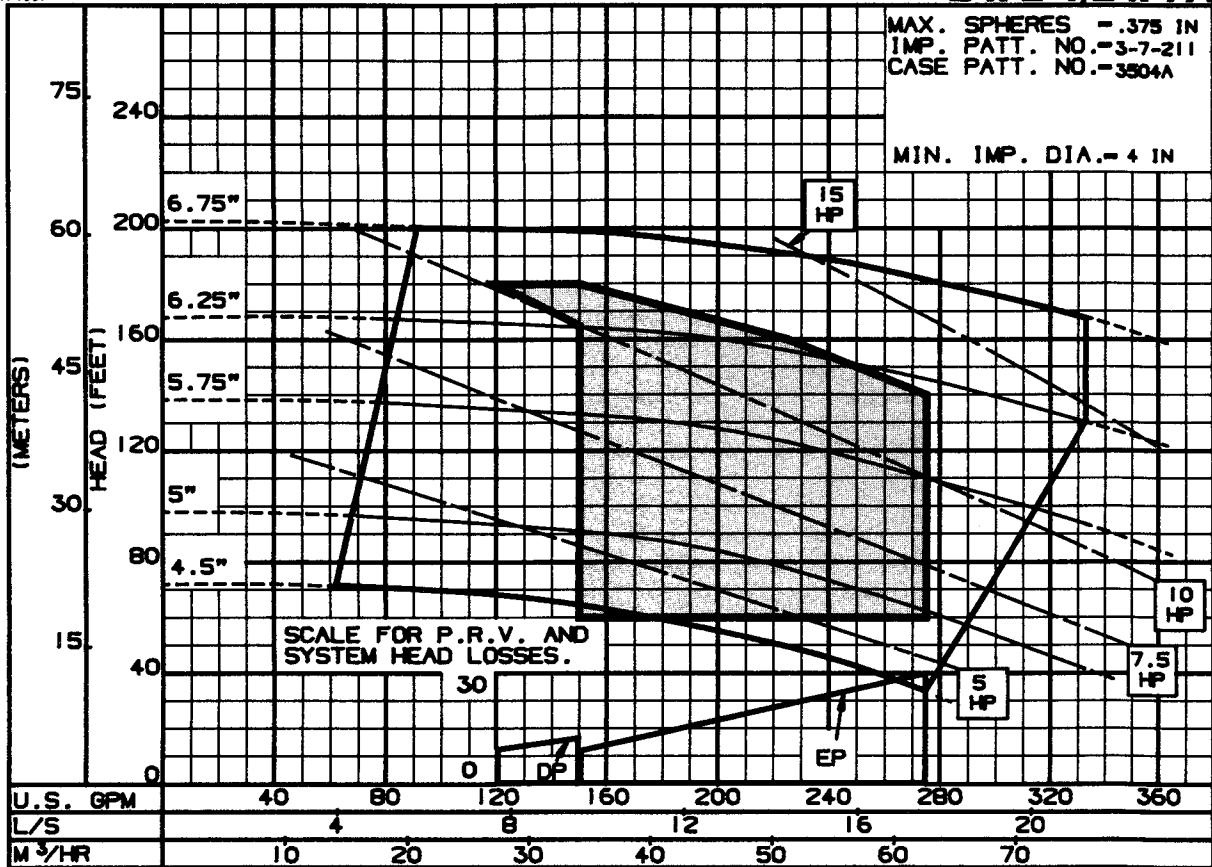

3PC-144229A

2 1/2 x 3 x 7B

**3500
R.P.M.**

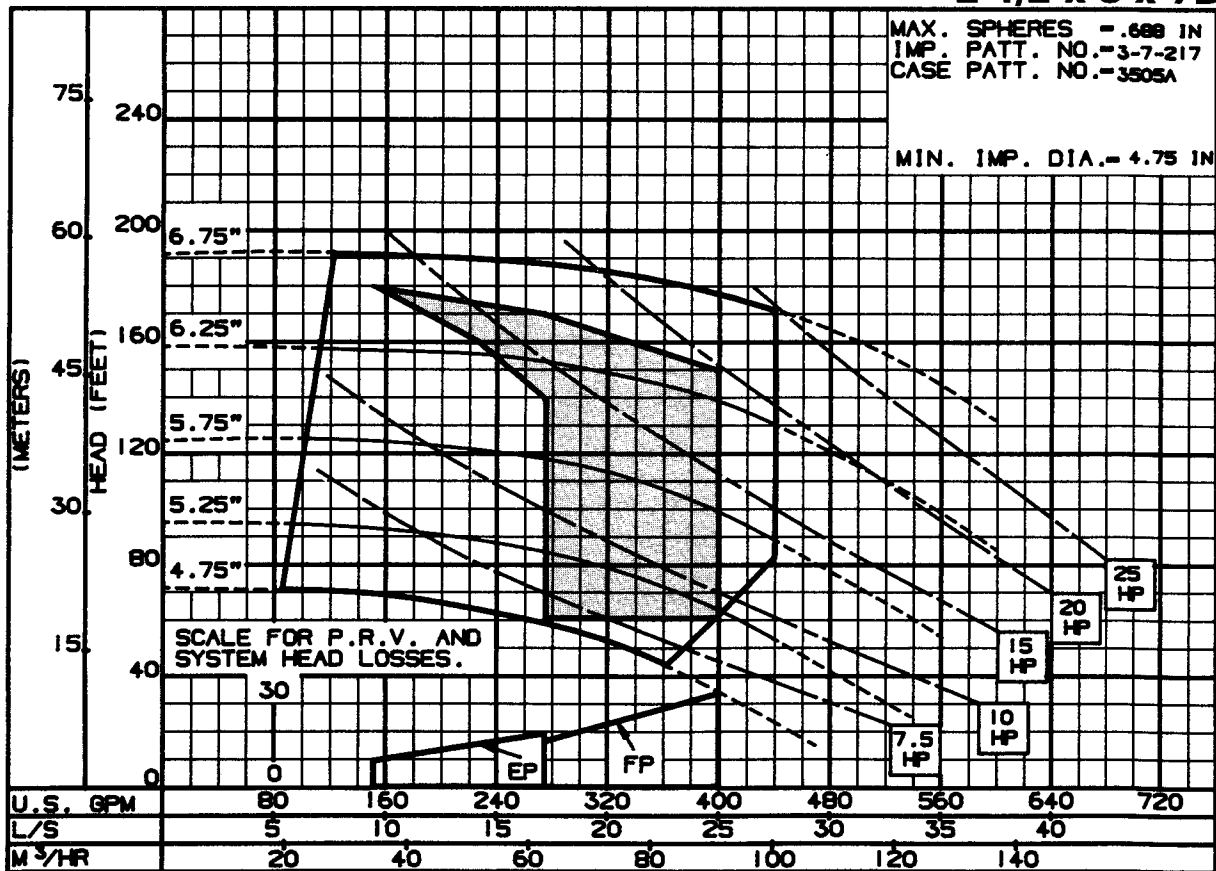

3PC-145004A

SERIES 750 / 760 ENCLOSED IMPELLER

Dated JULY 1989

SUPERSEDES PAGE 403

DATED NOVEMBER 1987

1 1/2 x 2 x 9C

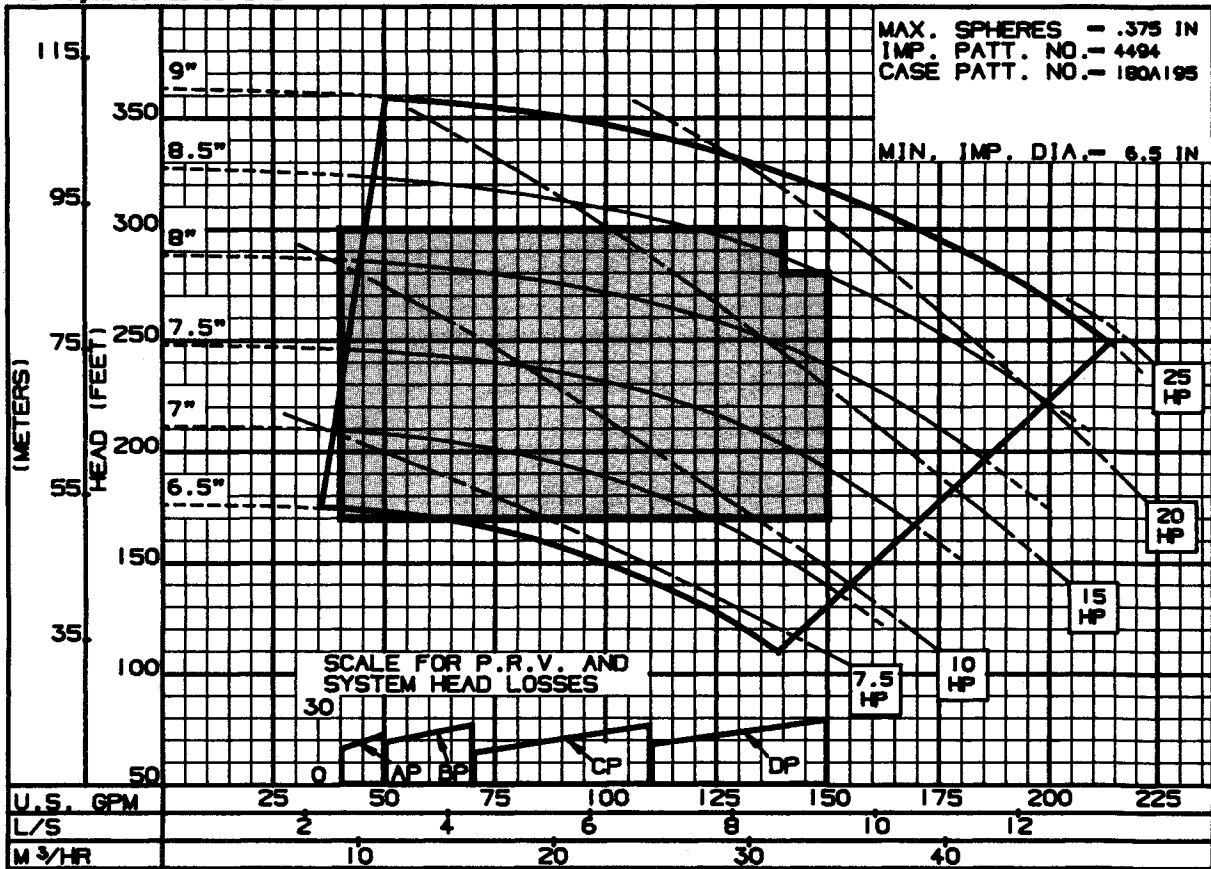

3PC-144230A

1 1/2 x 2 x 9C

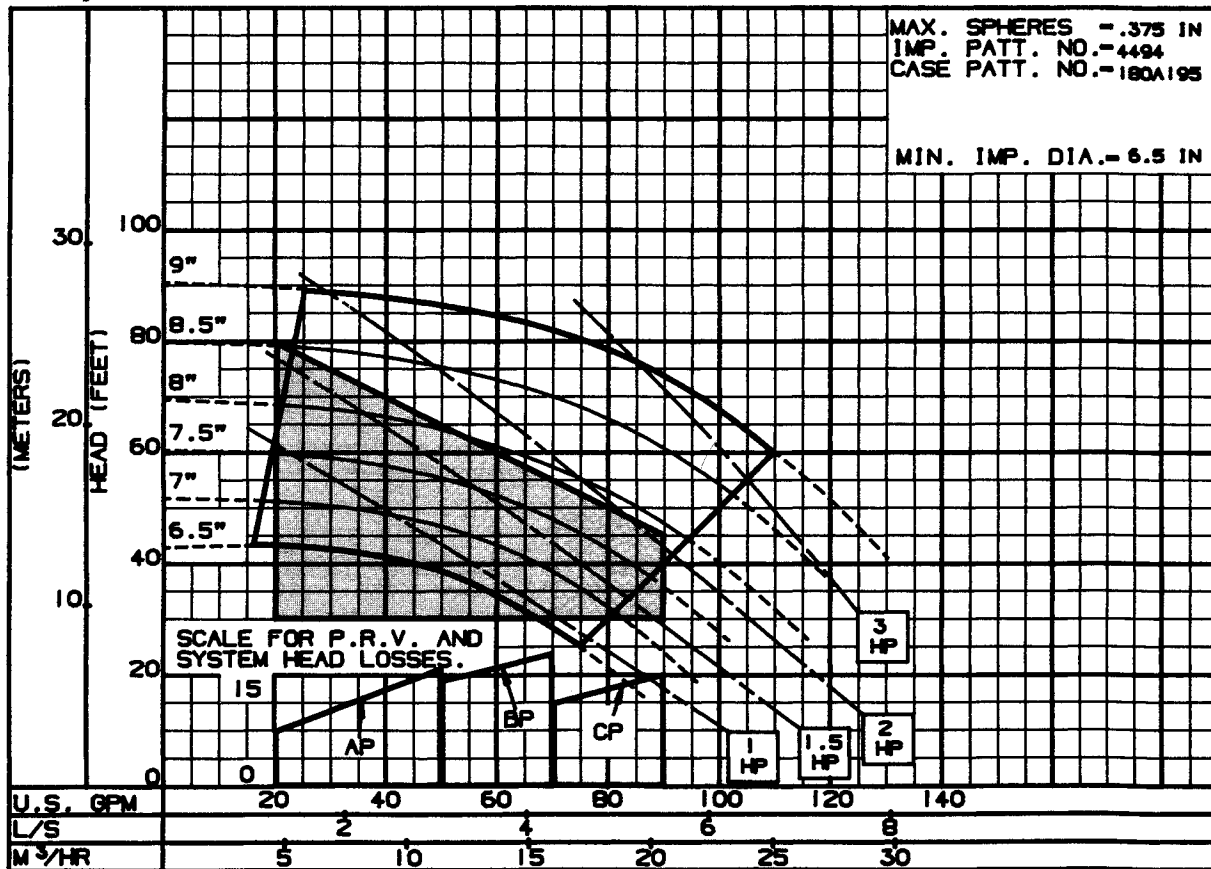

3PC-145006A

ap AURORA®

PENTAIR PUMP GROUP

SERIES 750 / 760 ENCLOSED IMPELLER

2 x 2 1/2 x 9

3500
R.P.M.

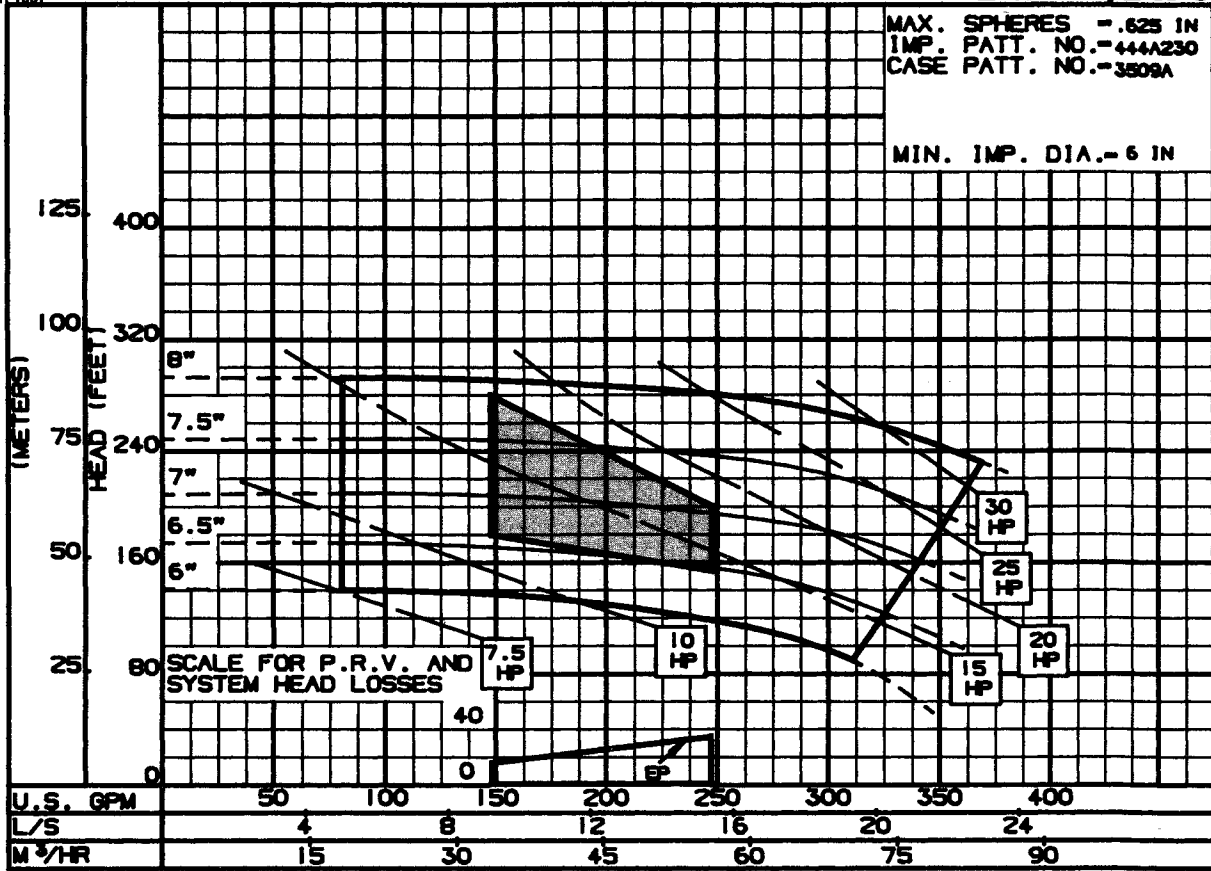

3PC-145008A

2 x 2 1/2 x 9

1750
R.P.M.

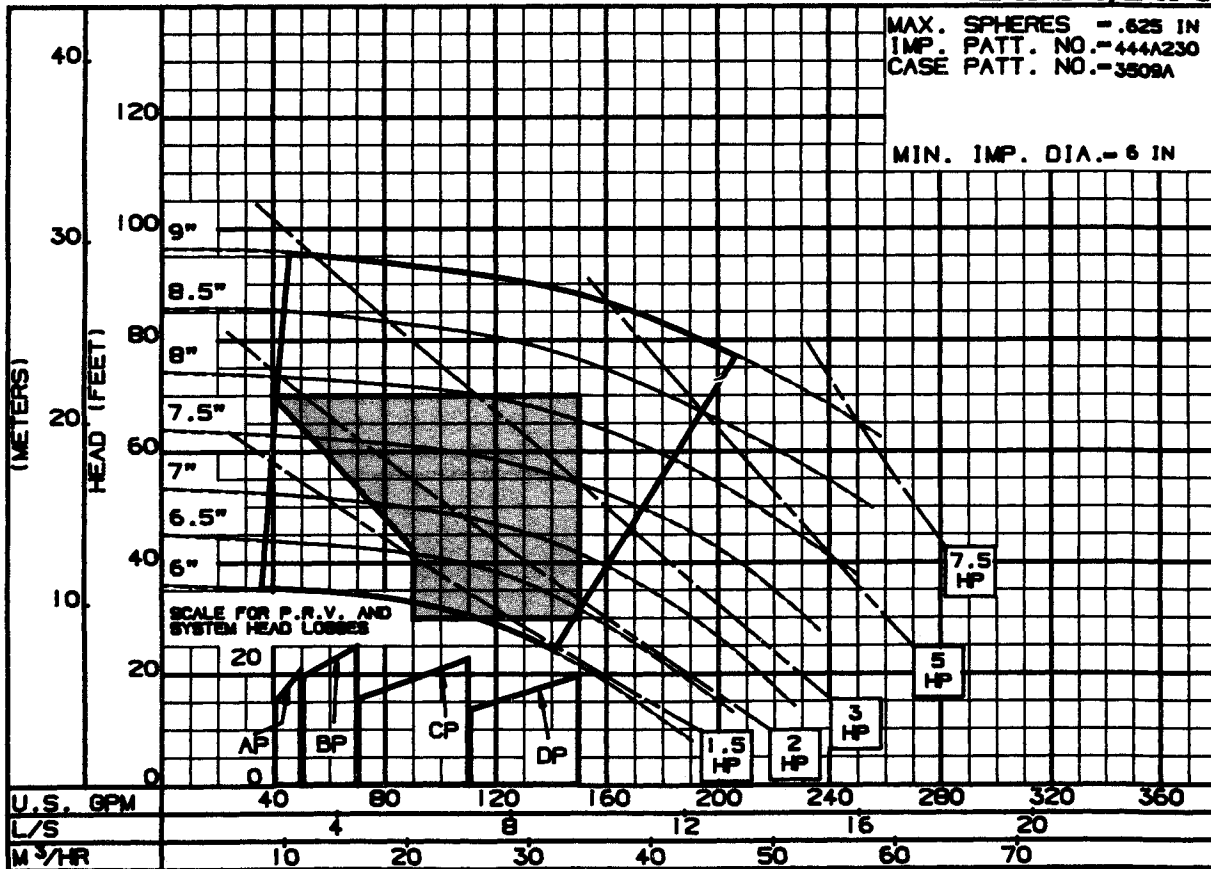

3PC-145009A

SERIES 750 / 760 ENCLOSED IMPELLER

Dated JULY 1989

SUPERSEDES PAGE 405
DATED NOVEMBER 1987

2 1/2 x 3 x 9

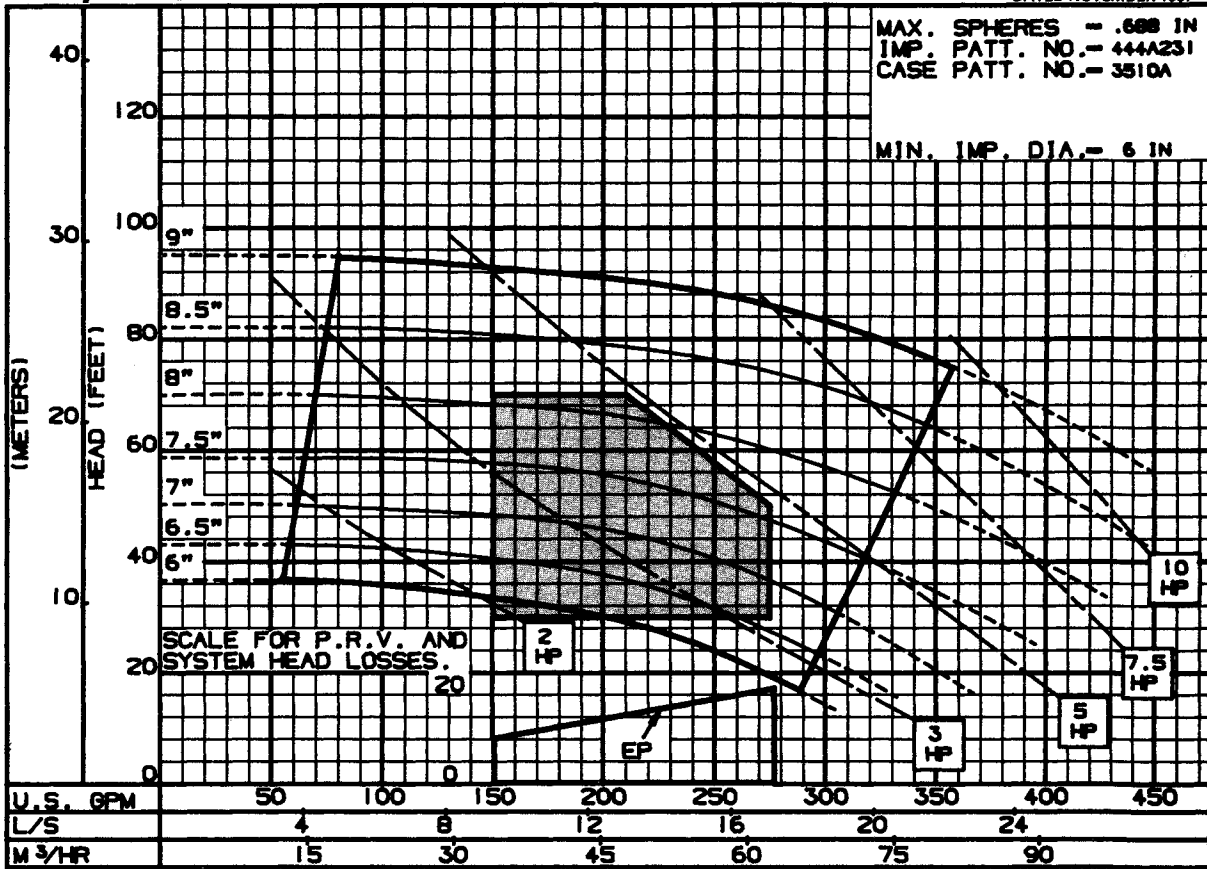

3PC-145005A

SERIES 750 / 760 ENCLOSED IMPELLER

2 x 3 x 11

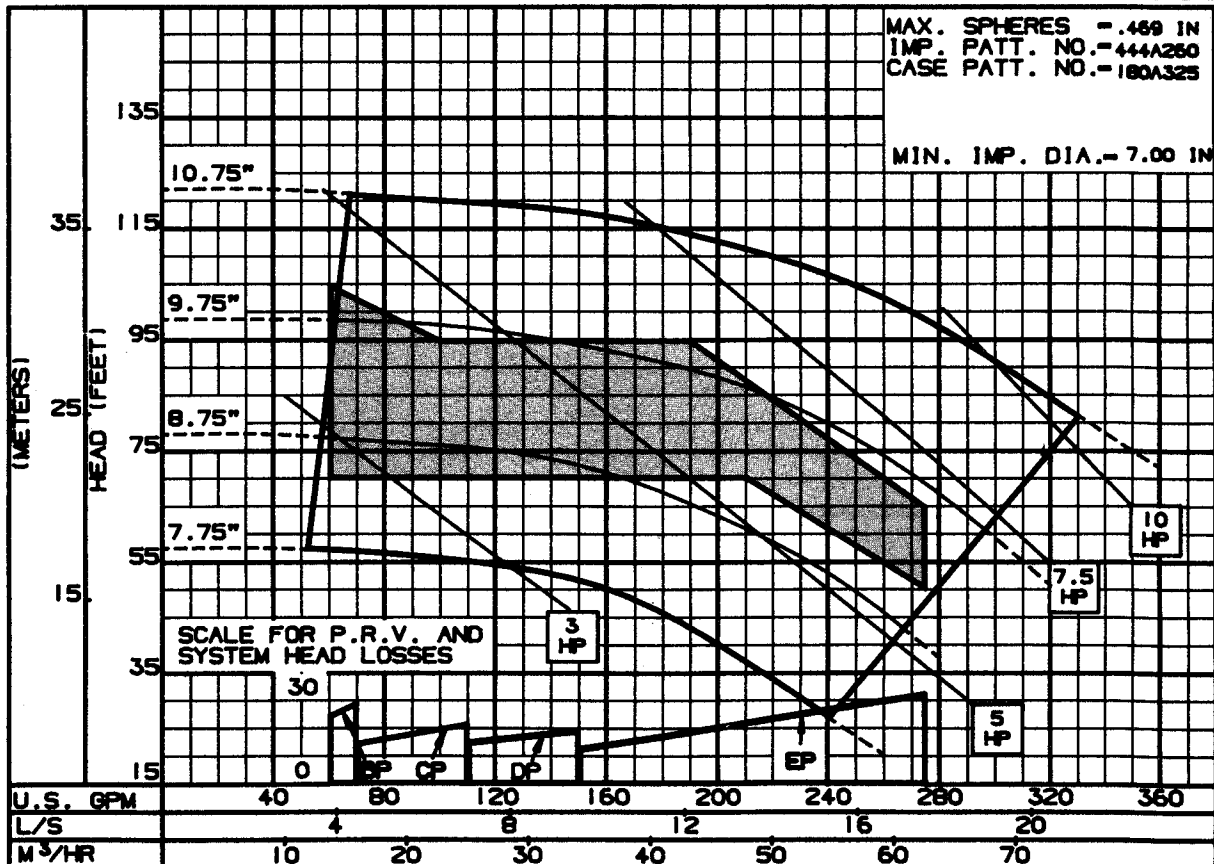

1750
R.P.M.

3PC-145010A

ap AURORA®

PENTAIR PUMP GROUP

SERIES 750 / 760 ENCLOSED IMPELLER

1 1/2 x 2 x 12

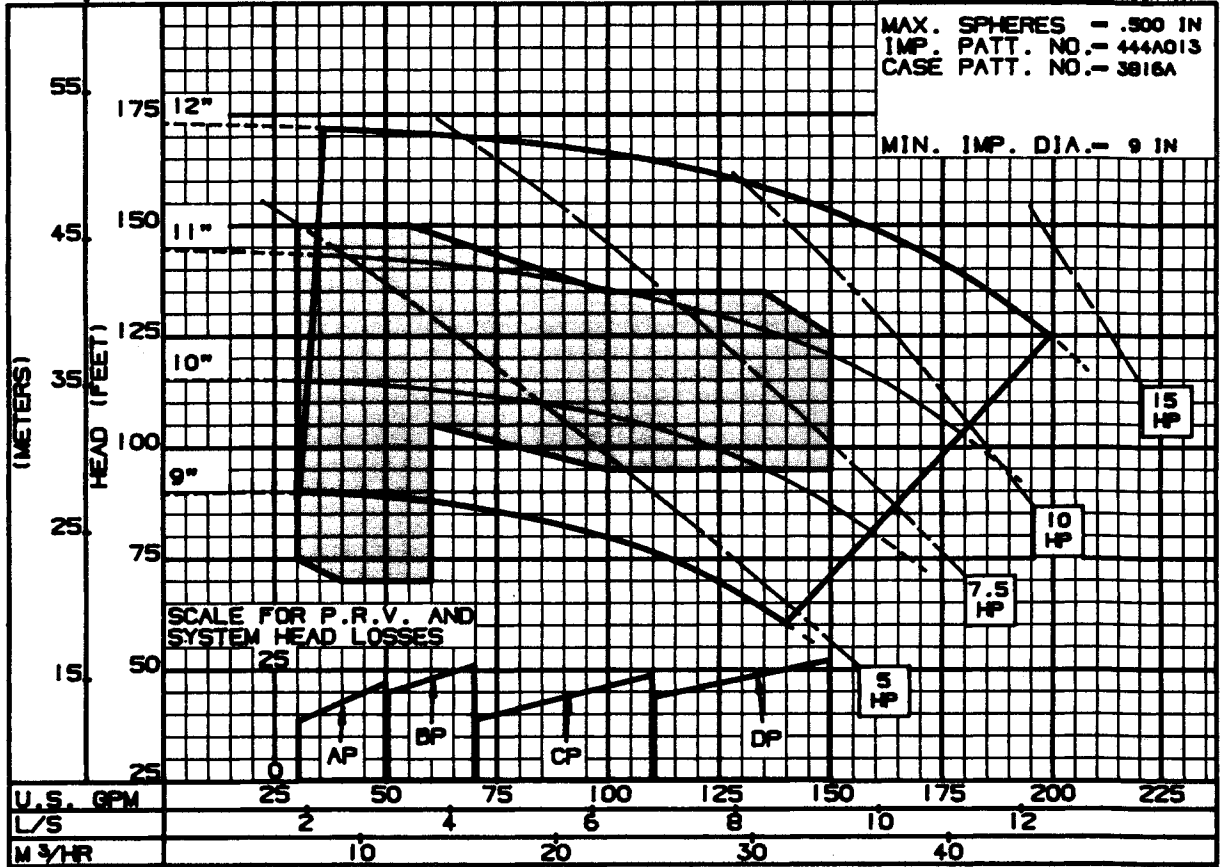

1750
R.P.M.

3PC-145007A

2 1/2 x 3 x 12

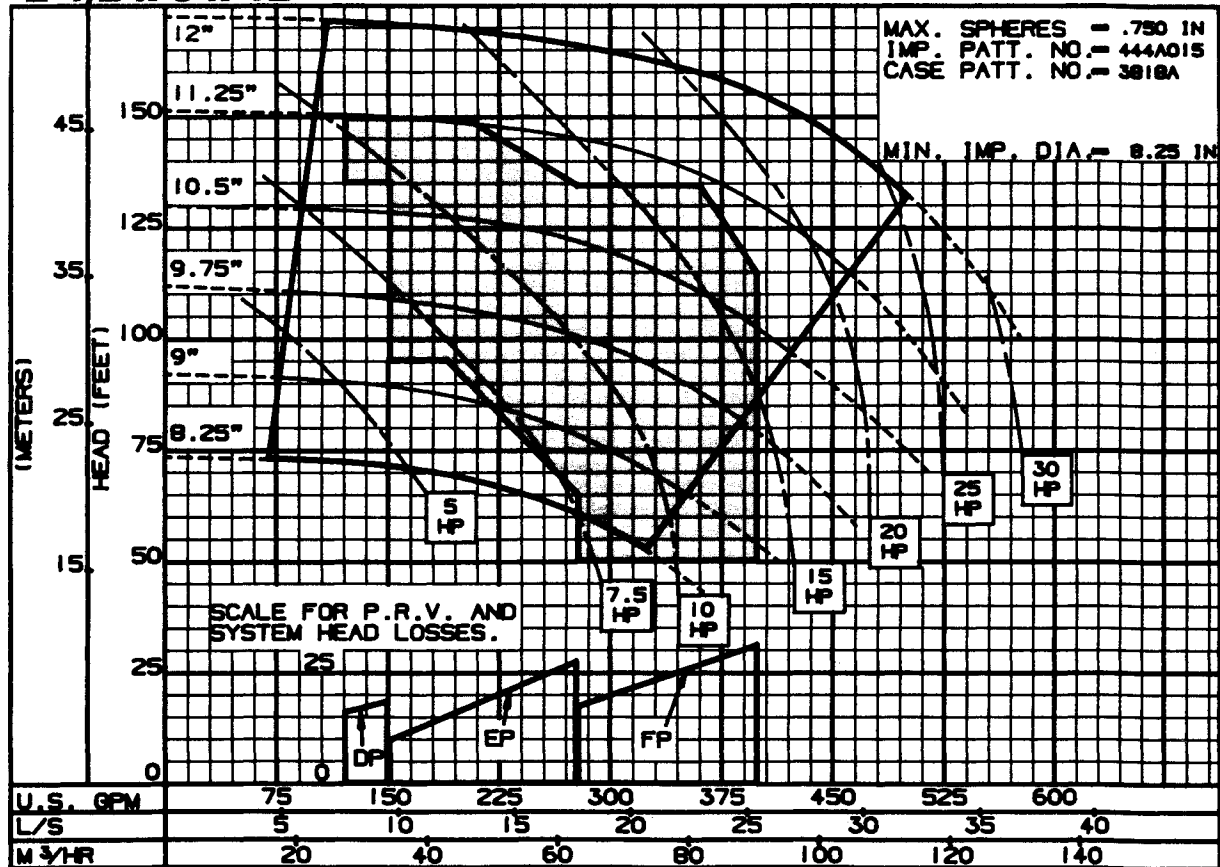

1750
R.P.M.

3PC-145011A

ap AURORA®

PENTAIR PUMP GROUP

CP Boss Constant Pressure Booster Systems

- Capacities to 1200 G.P.M. (272.5 M³/HR)
- Pressures to 175 PSI (123 M)
- Potable Water Application



Constant Pressure Pumping Introduction

CP Boss, Aurora Pump's Packaged Constant Pressure Booster Systems are designed to meet the ever increasing demand of variable flows in high-rise, commercial, municipal and industrial buildings. These PLC based systems are available in horizontal and vertical configurations. Easy to select and install, pre-engineered duplex and triplex units are available for quick delivery. Each system is performance tested for trouble free operation and ease of installation and start-up.

Feature Selector

STANDARD

- UL Labeled Pressure Sensing Control Panel
- PLC Pump Sequence Controller
- Duplex or Triplex
- Vertical or Horizontal Configurations
- Cast Iron, Bronze Fitted Centrifugal Pumps
- High Efficiency Motors
- Steel Manifolds
- Complete Factory Test
- Pilot Operated Pressure Regulating Valves
- Maximum Pressure up to 175psi, Maximum Flows up to 1200gpm
- Single Source Responsibility

OPTIONAL

- ASME rated Steel Bladder Tank
- Galvanized, Copper or Stainless Steel Headers
- Vertical Stackable Pumps
- Special Control Panels
- Current Sensing or Flow Sensing
- Simplex, Quadruplex Designs
- Specially Engineered Booster Systems for Higher Flows & Pressures



Packaged Constant Pressure Booster Systems described in this bulletin are used in offices and high rise buildings.

Pump Features

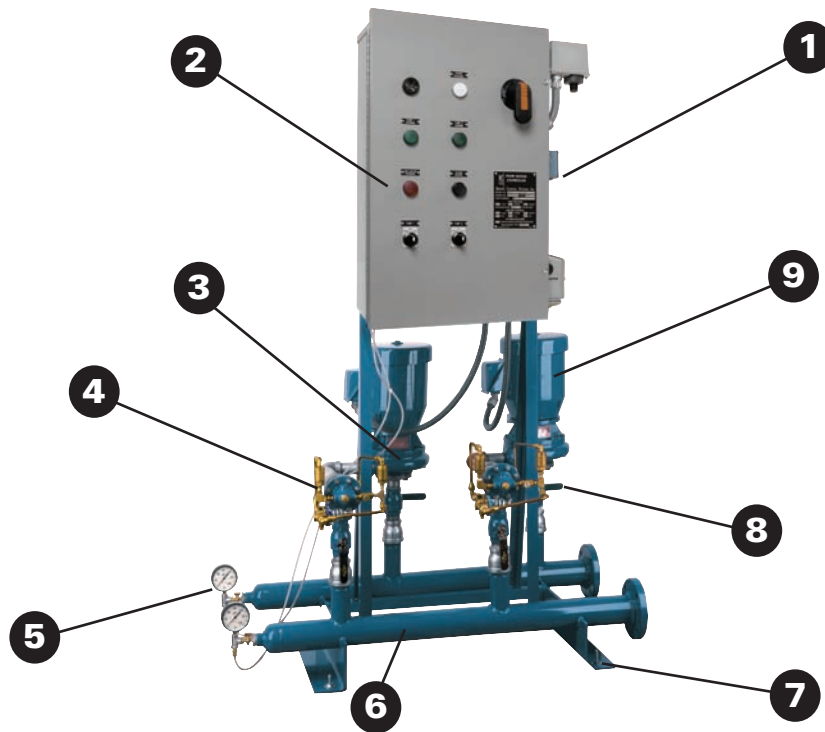

FEATURES

1. COMPLETELY ASSEMBLED and prewired for easy installation.
2. PRESSURE SENSING CONTROL PANEL: The Programmable Controller incorporated into the UL listed NEMA 1 Control Panel readily allows for the addition of optional control functions and alarm features.
3. SYSTEMS feature Aurora Pump 340 Series centrifugal end-suction pumps in bronze-fitted construction.
 - BRONZE SHAFT SLEEVE prevents shaft wear and extends the entire length of the seal box. Sleeve and impeller screw are sealed by o-ring gaskets to eliminate corrosion of the shaft by the liquid being pumped.
 - MECHANICAL SEAL has carbon against Ni-Resist face for optimum water performance. Long life is also assured with 303 stainless steel metal parts and Buna-N elastomers.
 - BACK PULL-OUT design simplifies disassembly. Suction and discharge piping is not disturbed and/or misaligned when servicing pumps. Standard motor approved by a joint NEMA and the HYDRAULIC INSTITUTE provides low noise level pump operation. Carbon steel motor shaft is designed for minimum deflection not to exceed .002" at seal faces when at maximum load. Bearings are selected for a long service life under severe operating conditions.
 - DYNAMICALLY BALANCED IMPELLER is keyed to the shaft. Quality controlled manufacturing process assures consistently high performance. Enclosed design provides highest efficiency and is vacuum cast. A case wearing ring prevents wear on the pump casing and is easily and inexpensively replaced as necessary.
4. PRESSURE REDUCING valves automatically reduce higher inlet pressure to a constant downstream pressure regardless of changing flow rate or inlet pressure. Pilot control settings are readily accessible and are easy to adjust. Return flow is prevented through built in check valves. For some applications where constant discharge pressure is not critical or where suction pressure is relatively constant as with a reservoir, silent check valves may be substituted for pressure reducing valves.
5. PRESSURE GAUGES are located on suction and discharge manifold.
6. STEEL MANIFOLDS are painted Aurora Blue for corrosion resistance and to meet various local codes. Flanged connections provide easy installation. All piping is Schedule 40.
7. WELDED GROUTABLE STEEL BASE provides complete support while still allowing the unit to be readily maneuvered for installation.
8. FULL-PORT BALL VALVES provided on each pump suction and discharge branch will allow individual pumps to be serviced without interrupted operation.
9. THERMAL RELIEF VALVE is installed in pump casing to prevent overheating and pump failure. The valve will automatically sense the rise in temperature and discharge some of the hot fluid causing the cooler fluid to enter the casing and the valve will then close.
10. HYDROPNEUMATIC PRESSURE TANK (not illustrated) can be optionally provided to maintain system pressure during periods of low demand. Depending on specific application, the tank can be located adjacent to the system in the equipment room, remotely located, or mounted with the system on the common baseplate.

Pump and System Selection Guide

All Packaged Booster Systems have a desired discharge pressure and a given suction pressure from the city water system, or from a suction tank. Individual pump boost pressure is usually the system boost plus the friction losses within the booster system pipe, fittings, and pressure reducing valves. Individual pump flow is usually two equal sized pumps on a duplex system, and a percentage such as 20% + 40% + 40% = 100% for a triplex system. Determine the system flow and boost as well as individual pump flow and boost.

- 1) Total System Flow in GPM _____
 Determine required flow per pump in GPM P1 _____
 (Total System Flow ÷ No. of Pumps) P2 _____
 P3 _____

- 2) Determine System Manifold Size

0 – 250 GPM	3"
0 – 450 GPM	4"
0 – 1200 GPM	6"

- 3) Determine Pump Head (TDH)

A:	Desired Pressure at System Discharge Manifold _____	PSIG
B:	Minimum Pump Suction Pressure _____	PSIG

(City Supply or Tank)

Determine PRV Size(s)

PUMP FLOW	50 GPM	70 GPM	110 GPM	150 GPM	275 GPM	400 GPM
PRV SIZE	1-1/4"	1-1/2"	2"	2-1/2"	3"	4"

C: Determine Flow Losses based on PRV Size _____ Ft. (See Chart Below)

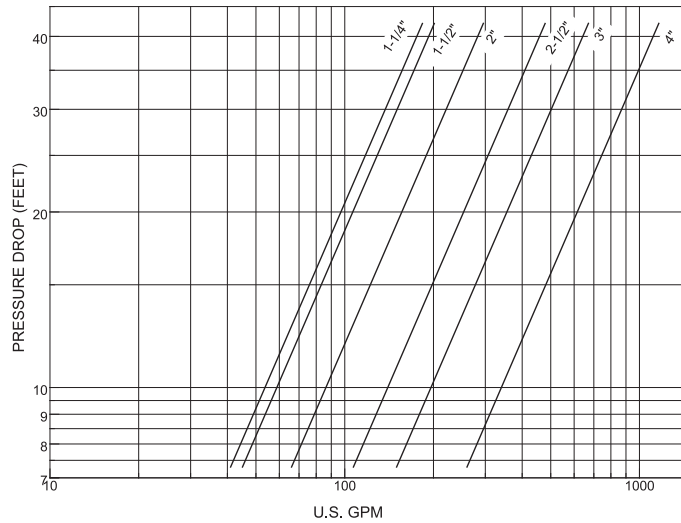

Calculate Required Pump TDH: [A - B] x 2.31 + C
 [(A) _____ PSIG - (B) PSIG] x 2.31 + _____ (C) Ft. = _____ Ft.

Individual Pump Duty Points:

P1	_____ GPM @ _____	Ft. TDH
P2	_____ GPM @ _____	Ft. TDH
P3	_____ GPM @ _____	Ft. TDH

- 4) Select required pumps and motors using Aurora H2Optimize or the current Aurora Pump catalog

Range Charts

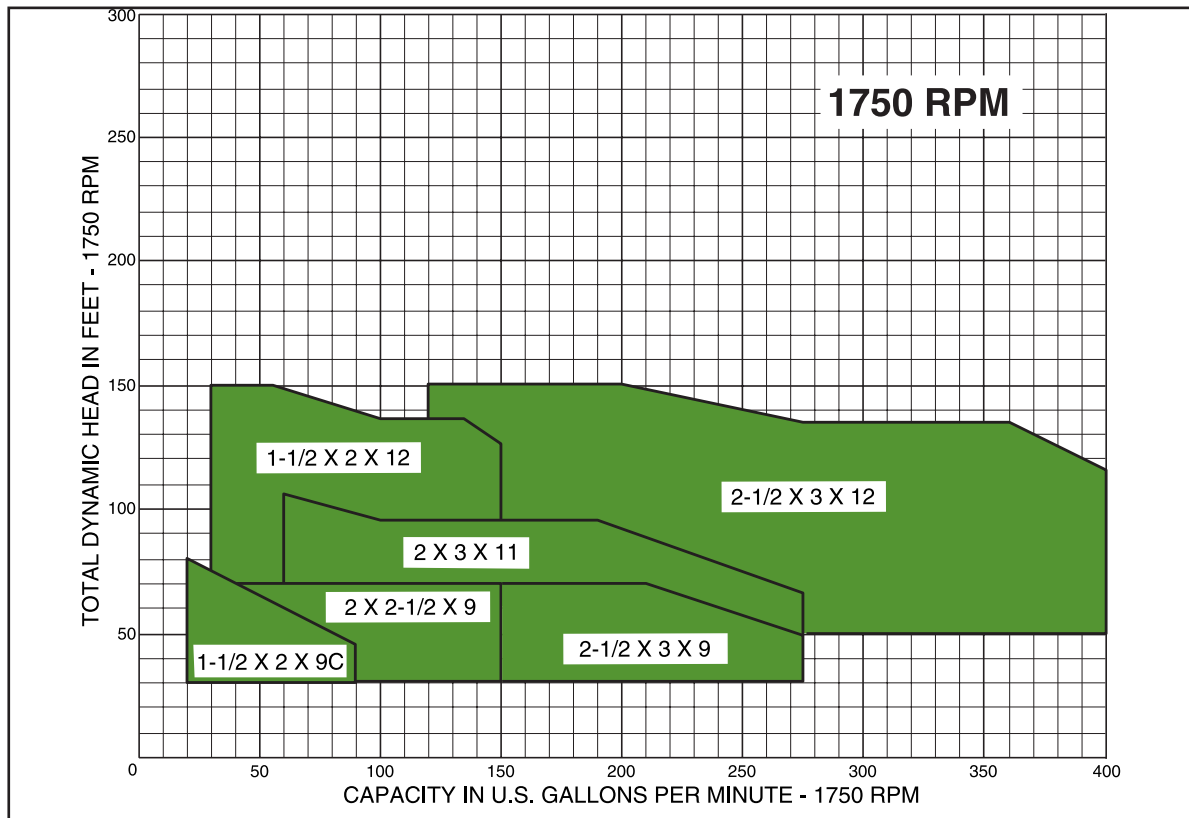
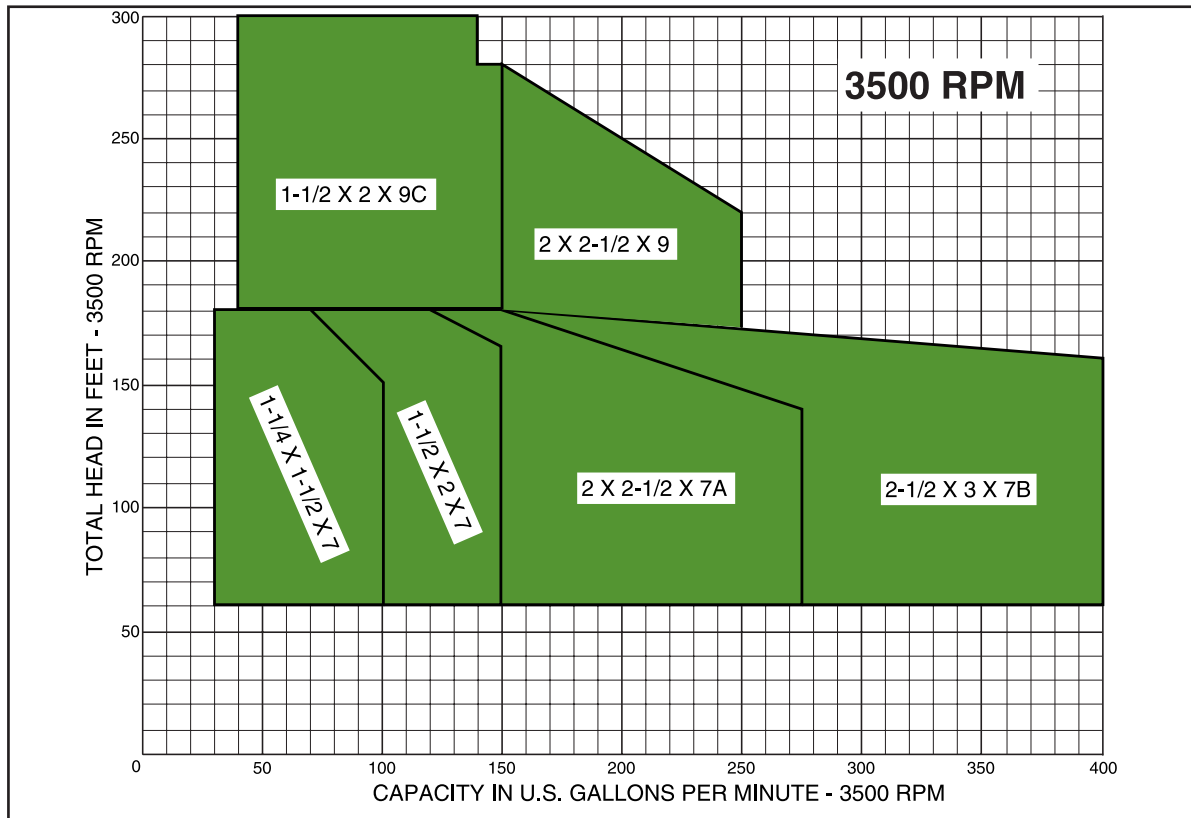

VERTICAL DUPLEX

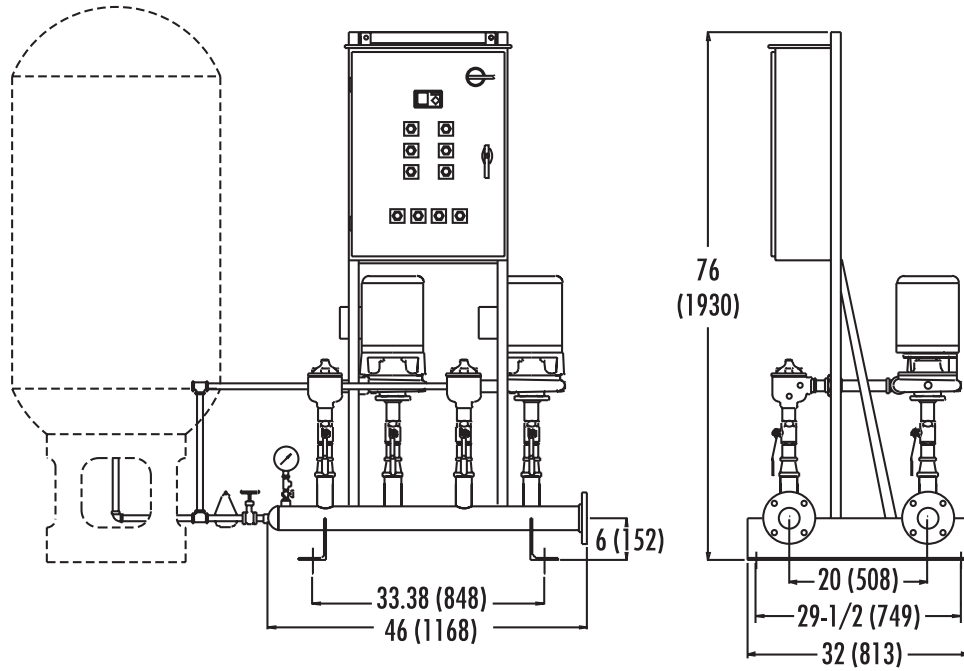

VERTICAL TRIPLEX

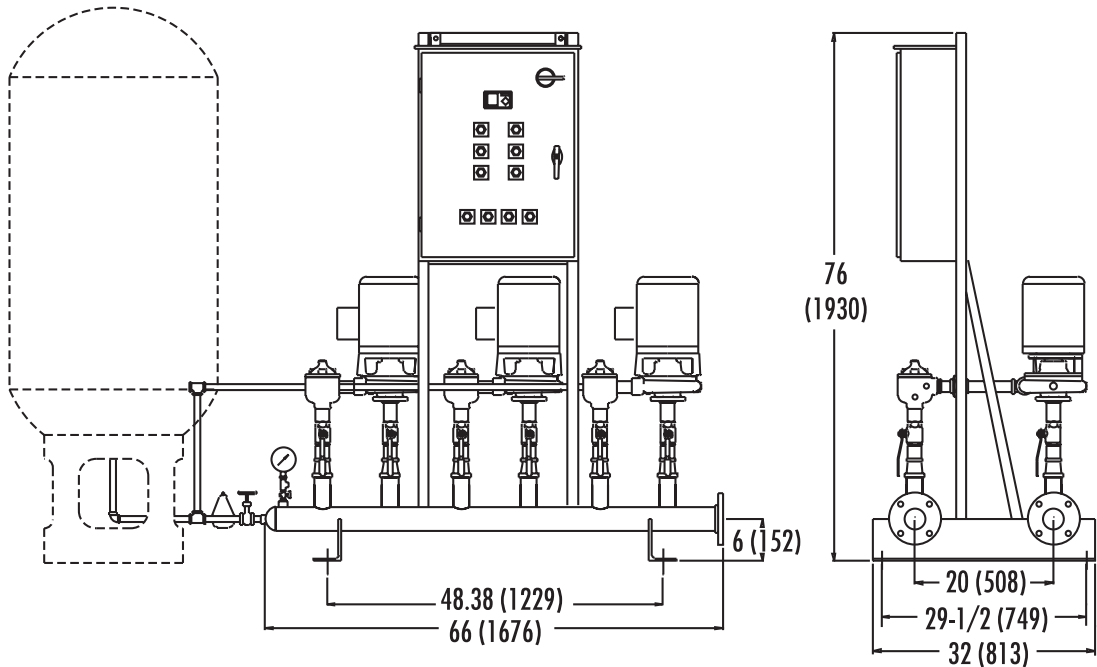

HORIZONTAL DUPLEX

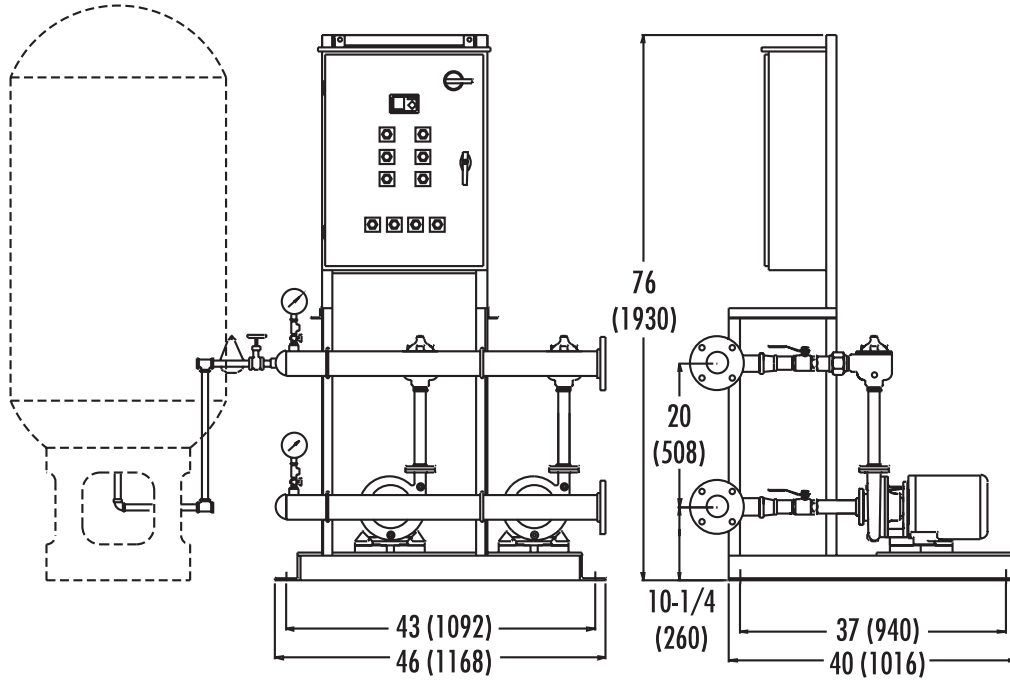

HORIZONTAL TRIPLEX

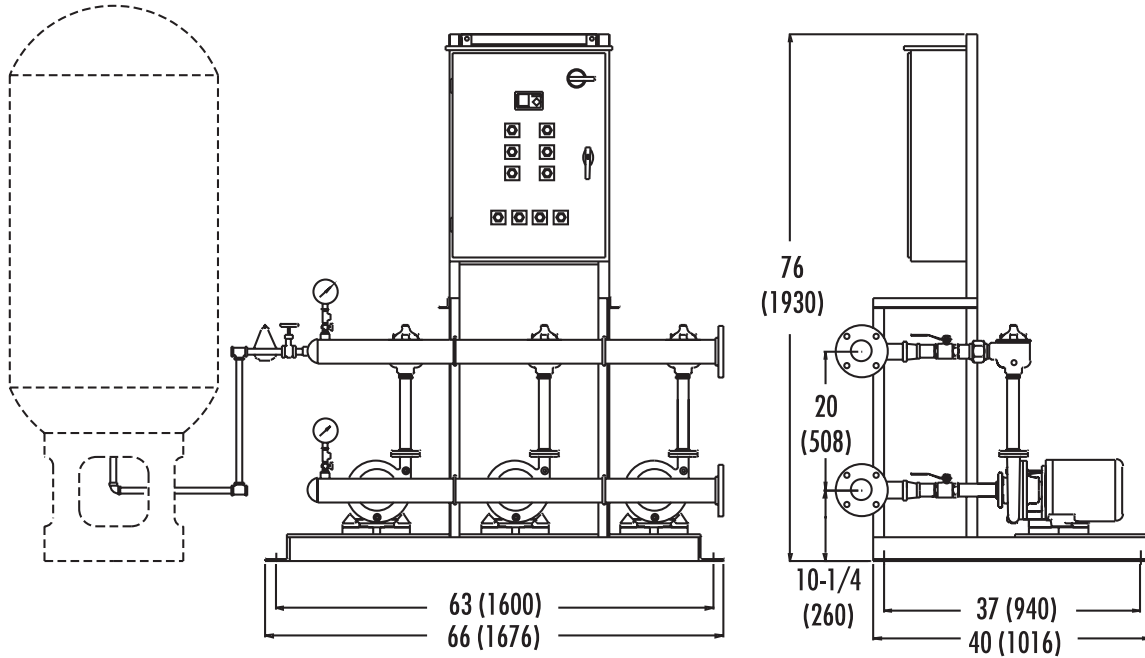

Engineering Specifications

The contractor shall furnish and install an Aurora Variable Flow (Duplex or Triplex) constant Pressure Booster System as manufactured by Aurora Pump. The unit shall have a total system capacity of.....GPM at a discharge head of.....feet when supplied with a working suction head of.....feet. Each pump shall be sized as indicated for a % of the total flow.

Duplex System

PumpP1 =.....GPM.....%System

PumpP2 =.....GPM.....%System

Triplex System

PumpP1 =.....GPM.....%System

PumpP2 =.....GPM.....%System

PumpP3 =.....GPM.....%System

PIPING AND VALVES

Each system shall be skid mounted, completely assembled and wired on a groutable steel base ready for installation. All piping shall be Schedule 40 Steel pipe. Each system shall include suction and discharge ball valves for each pump suction and discharge, combination pressure regulating/non-slam check valves for each pump, flanged connections for easy installation and pipe supports for the upper manifold. Suction and discharge pressure

gauges shall be provided. Gauges shall have 3-1/2" faces with large scale numerals and individual air bleed type valves.

PUMPS

The pumps shall be Aurora horizontal or vertical close-coupled end suction centrifugal pumps with back pullout design. The pump shall be constructed of cast iron casing, bronze dynamically balanced impeller, bronze shaft sleeves, and bronze case wear rings. Shaft sealing shall be accomplished by means of a stainless steel mechanical seal.

MOTORS

The motors shall be NEMA type JM, closed coupled,HP, 3 phase, 60 Hertz,Volt, ODP, High-Efficiency. Motors shall be selected so that they do not exceed their nameplate HP rating through their entire range of operation.

CONTROL PANEL-PRESSURE SENSING

Each system shall have a mounted and wired UL Listed NEMA I Control Panel with individual magnetic motor starters, ambient compensated overload relays on each phase, individual motor fuseblocks with fuses, main circuit disconnect switch with door interlock, 110 volt control transformer with primary and secondary fuses. The panel

shall be suitable for the horsepower and voltage of the motors. The Control Panel will incorporate a programmable logic controller with pressure-sensing logic and have the following features:

- On and Off delays factory set to system operating characteristics to prevent short cycling of pumps.
- Individual pump run lights and selector switches
- Failure logic and indicating light to activate second pump if lead pump malfunctions.
- Automatic Lead/Lag pump alternation
- Low suction pressure shutdown with alarm light, horn and reset button.

TESTING

The entire system shall be tested at the factory to assure proper sequencing to meet the design flows and pressure; and the system components shall be adjusted at the factory.

SERVICES

The pump manufacturer shall assume unit responsibility and shall provide a factory trained engineer to supervise initial start-up to insure proper operation and to instruct the operating personnel in the operation and maintenance of the system.



NOTE: Aurora Pump reserves the right to make revisions to its products and their specifications, and to this bulletin and related information, without notice.

— Your Authorized Local Distributor —



MARKETING & SALES:

800 AIRPORT ROAD • NORTH AURORA, ILLINOIS U.S.A. • 60542
 PHONE: (630) 859-7000 U.S.A./CANADA FAX: (630) 859-7060
 WORLDWIDE FAX: (630) 859-1226

WEB: www.aurorapump.com

EMAIL: aurora_info@pentairpump.com

AURORA MFG. PLANT:

800 AIRPORT ROAD • NORTH AURORA, ILLINOIS U.S.A. • 60542

SALES OFFICES IN ALL MAJOR CITIES AND COUNTRIES

Refer to "Pumps" in yellow pages of your phone directory for your local Distributor.



AURORA 770 CP BOSS

SELECTION DATA

DETERMINE PRV SIZE(S):

(PRV size is based on individual pump flows)

PUMP FLOW	≤ 80 GPM	≤ 150 GPM	≤ 250 GPM	≤ 400 GPM
PRV SIZE	1-1/2"	2"	2-1/2"	3"

Duplex: PRV1 _____ in. Triplex: PRV1 _____ in.
 PRV2 _____ in. PRV2 _____ in.
 PRV3 _____ in.

DETERMINE SYSTEM/PIPING/PRV FLOW LOSSES:

C: Determine Flow Losses based on PRV size: _____ FT.

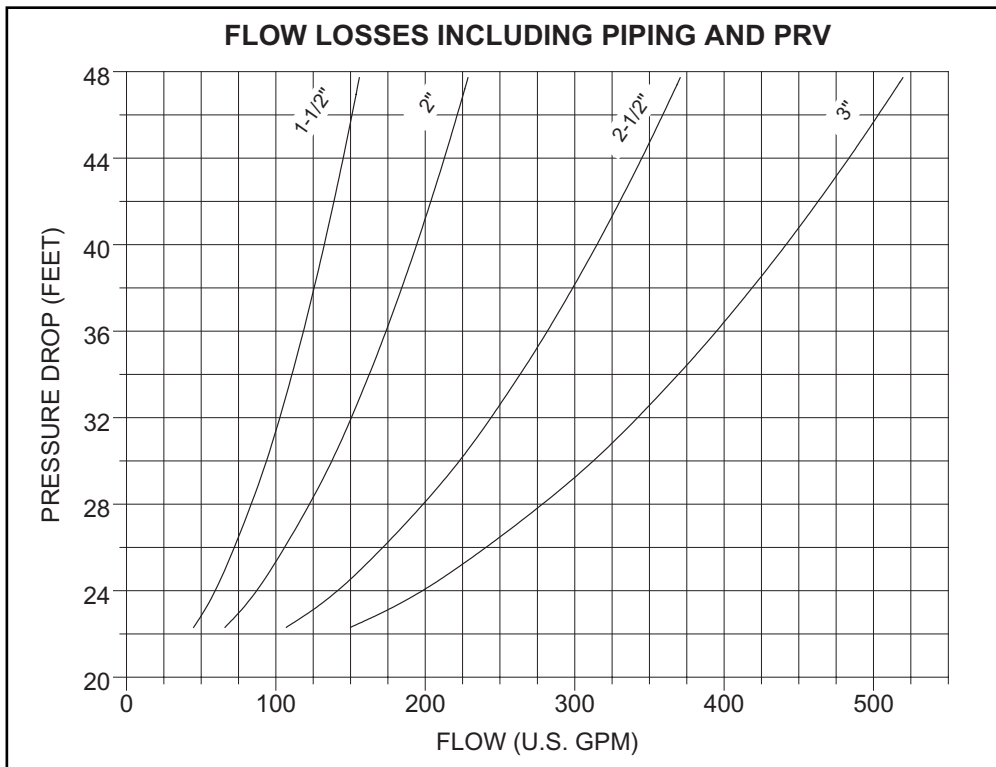

(See Chart Below)

Duplex: P1 Flow Losses _____ Ft (C1) Triplex: P1 Flow Losses _____ Ft (C1)
 P2 Flow Losses _____ Ft (C2) P2 Flow Losses _____ Ft (C2)
 P3 Flow Losses _____ Ft (C3)

CALCULATE REQUIRED PUMP TDH: [(A - B) X 2.31] + C

A: Required System Discharge Pressure (From Field Conditions)

B: System Suction Pressure (From Field Conditions)

C: (1,2,3): Flow Losses (From Chart Above)

SELECTION DATA

Dated **August 2002**

$$\begin{aligned}
 P1 & \quad [(A) \underline{\hspace{1cm}} \text{ PSIG} - (B) \underline{\hspace{1cm}} \text{ PSIG}] \times 2.31 + (C1) \underline{\hspace{1cm}} \text{ Ft.} = \underline{\hspace{1cm}} \text{ Ft.} \\
 P2 & \quad [(A) \underline{\hspace{1cm}} \text{ PSIG} - (B) \underline{\hspace{1cm}} \text{ PSIG}] \times 2.31 + (C2) \underline{\hspace{1cm}} \text{ Ft.} = \underline{\hspace{1cm}} \text{ Ft.} \\
 P3 & \quad [(A) \underline{\hspace{1cm}} \text{ PSIG} - (B) \underline{\hspace{1cm}} \text{ PSIG}] \times 2.31 + (C3) \underline{\hspace{1cm}} \text{ Ft.} = \underline{\hspace{1cm}} \text{ Ft.}
 \end{aligned}$$

Individual Pump Duty Points:

P1 GPM @ Ft. TDH
 P2 GPM @ Ft. TDH
 P3 GPM @ Ft. TDH

TANK SELECTION & MOUNTING OPTIONS:

Select the tank size required:

120-132 gallon 158-165 gallon 211-220 gallon

Select tank pressure:

125 175

Tank mounting:

Remote (by others) Factory mounted on system base

PUMP & MOTOR SELECTION:

Select required pumps from the CP Boss Bulletin. Curves are available from the 340 section of the Aurora Pump catalog or H2Optimize.

CONTROL PANEL SELECTION:

Control Panel Configuration:

Duplex Triplex

Controller Voltage:

208 230 460

Pump Horsepower Requirements:

Duplex: P1 HP Triplex: P1 HP
 P2 HP P2 HP
 P3 HP

Pump Sequencing:

Pressure Sensing Flow Sensing Current Sensing

Control Panel Options

- A High System Pressure Switch & Light
- B High Suction Pressure Switch & Light
- C Low System Pressure Switch & Light
- D Three Phase Lightning Arrestor
- E O/L Trip Light (alarm w/silence PB Std)
- F Failure to Start Light
- G Circuit Breakers in Place of Fuses
- H Individual Motor Disconnects
- J NEMA 4 Enclosure
- K NEMA 12 Enclosure
- L PLC Display Module

AURORA 770 CP BOSS

SELECTION DATA

Control Panel Options Cont.

- M PLC Computer Link Cable
- N PLC Memory Cartridge
- P Lead/Lag Manual Selector Switch
- Q Remove Alarm Contacts
- R Space Heater with Thermostat
- T Tank Pressure Switch
- W Elapsed Time Meter
- X Pressure Transducer
- Z PLC Real Time Clock

SYSTEM TESTS:

Standard Factory Test: All CP Boss systems are factory tested to assure proper sequencing to meet the design flows and pressure.

OPTIONAL FACTORY TESTS

- Certified Test
- Witness Test

SYSTEM DIMENSIONS:

Dimension Page _____ (from catalog)

AURORA MODEL CP BOSS

HORIZONTAL DUPLEX WITHOUT TANK

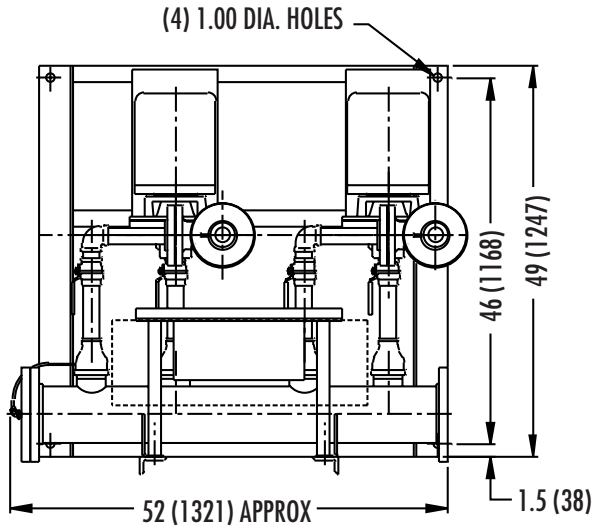

NOTES:

1. All dimensions in inches (mm) and may vary $\pm 1/2"$ (13).
2. Not for construction purposes unless certified.
4. Manifold flanges are ANSI Standard Class 125 Flat Face.
5. Standard (right hand) assembly is shown. Consult factory for other configurations.

MOTOR	AY MAX.
145JM	0
182JM	0
184JM	0
213JM	1.00
215JM	0.50
254JM	1.25
256JM	1.00
284JM	1.50
286JM	1.50

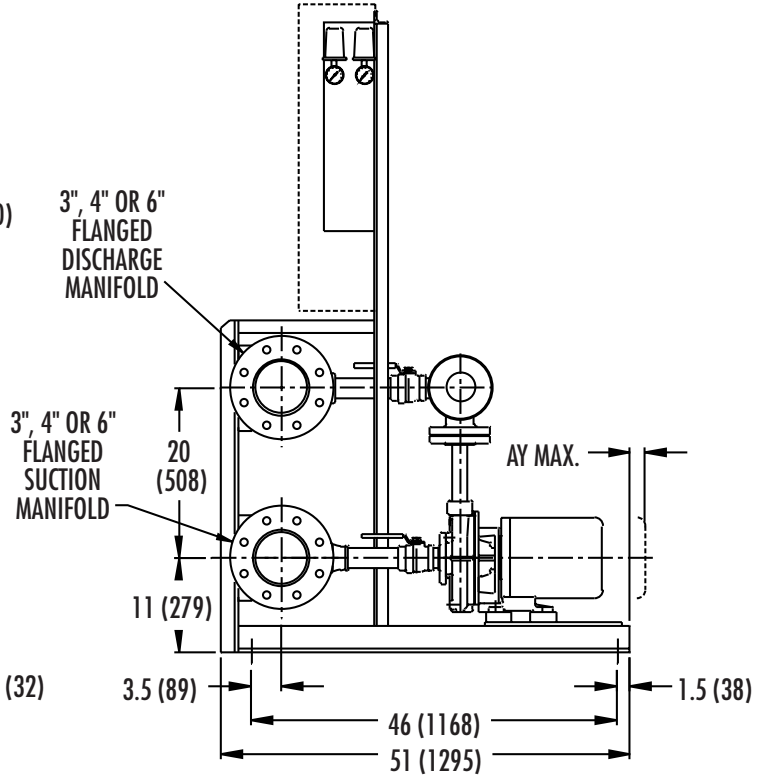
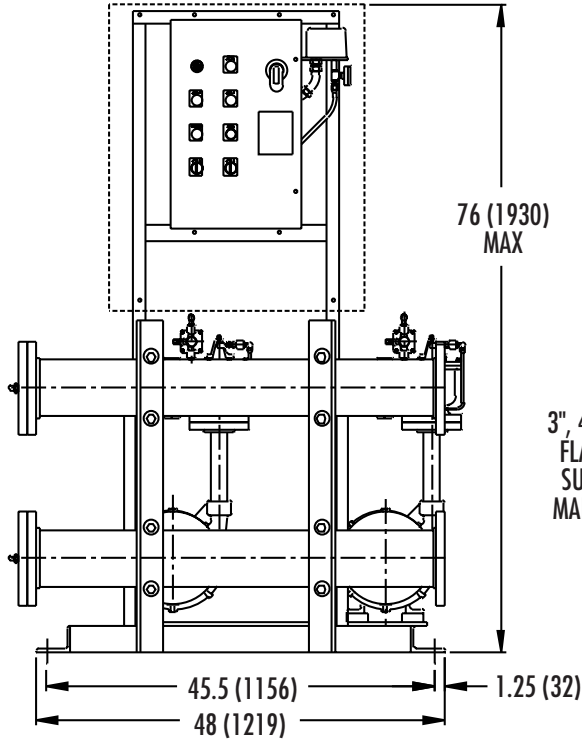

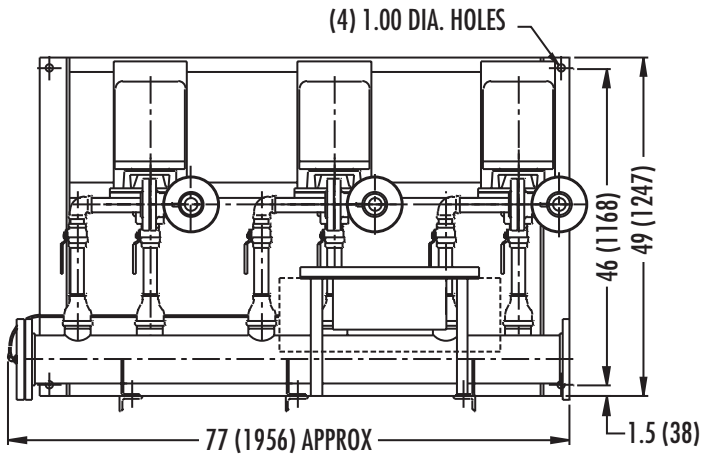

NOTES:

1. All dimensions in inches (mm) and may vary $\pm 1/2"$ (13).
2. Not for construction purposes unless certified.
4. Manifold flanges are ANSI Standard Class 125 Flat Face.
5. Standard (right hand) assembly is shown. Consult factory for other configurations.

MOTOR	AY MAX.
145JM	0
182JM	0
184JM	0
213JM	1.00
215JM	0.50
254JM	1.25
256JM	1.00
284JM	1.50
286JM	1.50

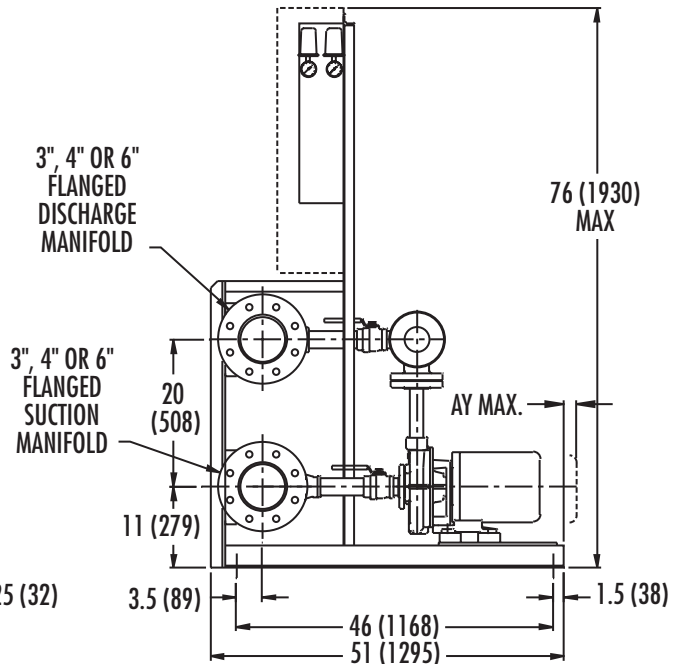
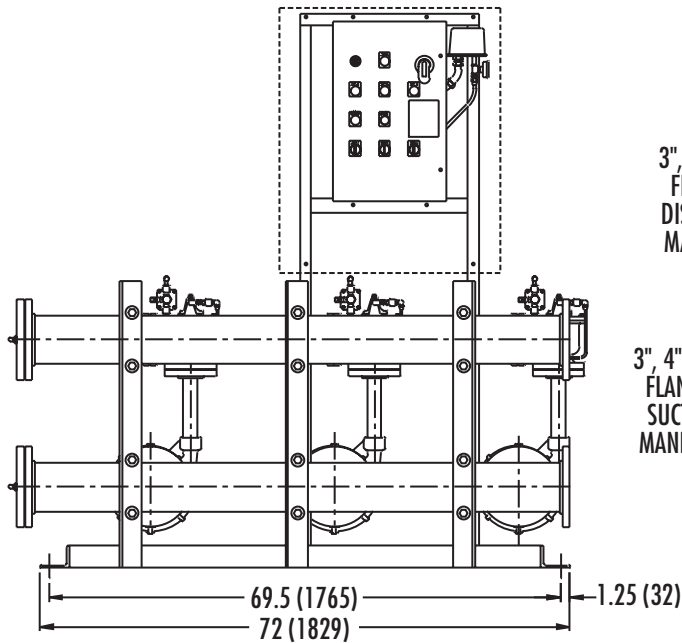

AURORA MODEL CP BOSS

VERTICAL DUPLEX WITHOUT TANK

Section **770** Page **203**

Date **January 2003**

Supersedes Section 770 Page 203
Dated August 2002

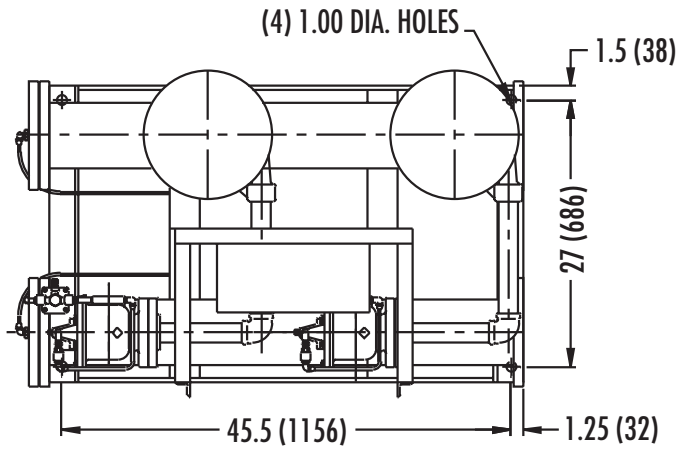

NOTES:

1. All dimensions in inches (mm) and may vary $\pm 1/2"$ (13).
2. Not for construction purposes unless certified.
4. Manifold flanges are ANSI Standard Class 125 Flat Face.
5. Standard (right hand) assembly is shown. Consult factory for other configurations.

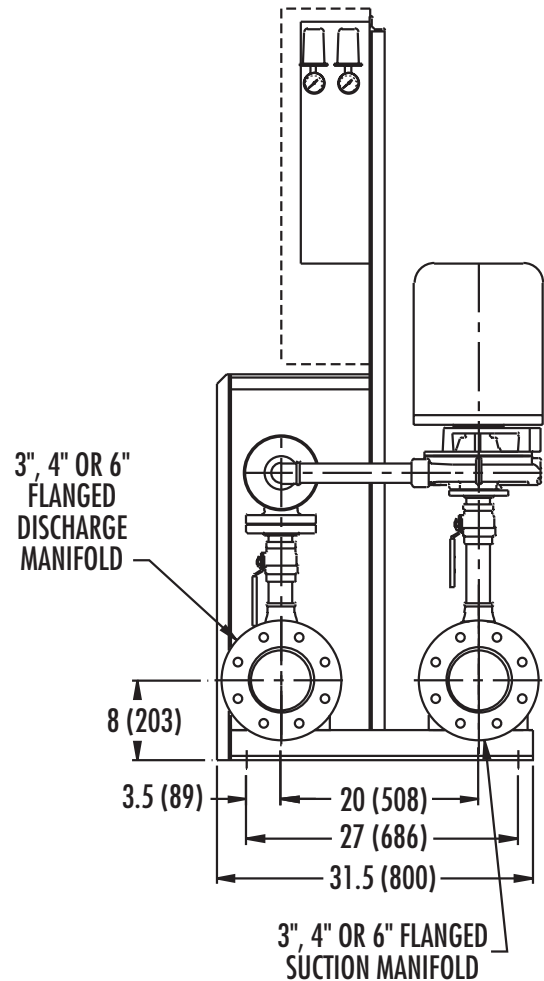
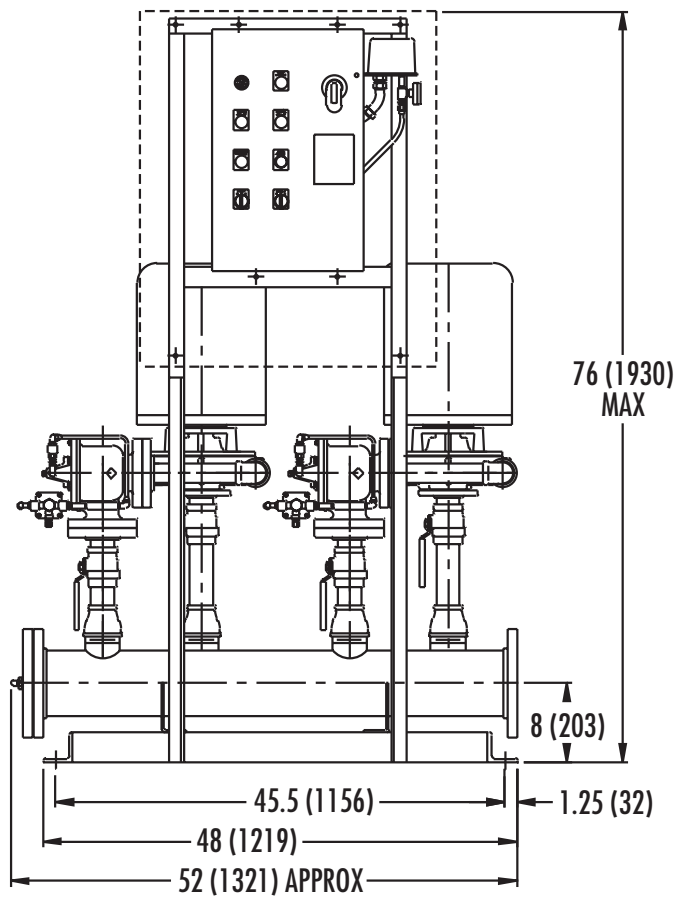

AURORA MODEL CP BOSS

Date **January 2003**

VERTICAL TRIPLEX
WITHOUT TANK

Supersedes Section 770 Page 204

Dated August 2002

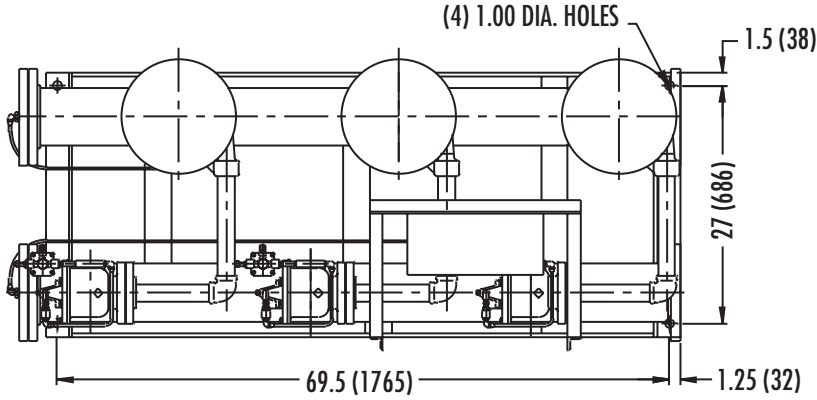

NOTES:

1. All dimensions in inches (mm) and may vary $\pm 1/2"$ (13).
2. Not for construction purposes unless certified.
4. Manifold flanges are ANSI Standard Class 125 Flat Face.
5. Standard (right hand) assembly is shown. Consult factory for other configurations.

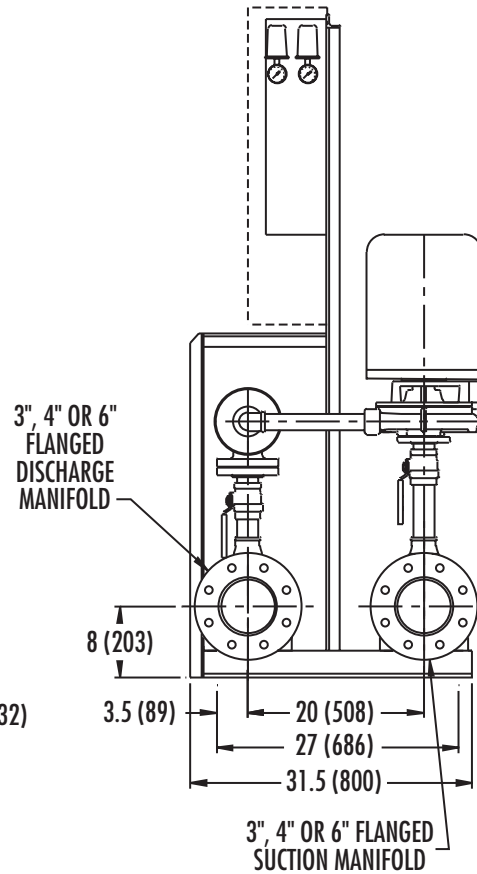
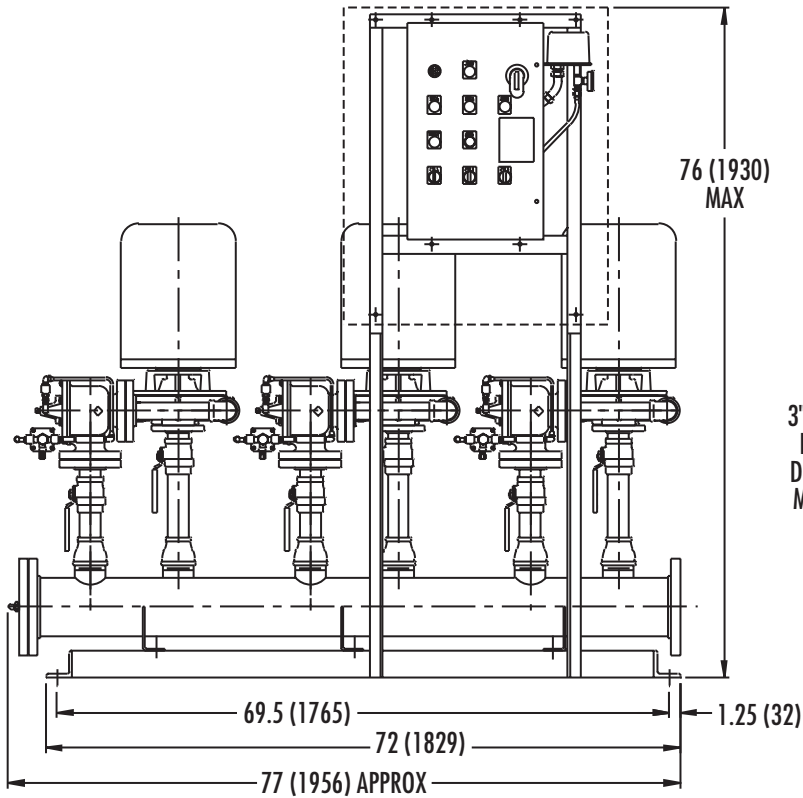

AURORA MODEL CP BOSS

HORIZONTAL DUPLEX WITH BASE MOUNTED TANK

Section **770** Page **205**

Date **January 2003**

Supersedes Section 770 Page 205
Dated August 2002

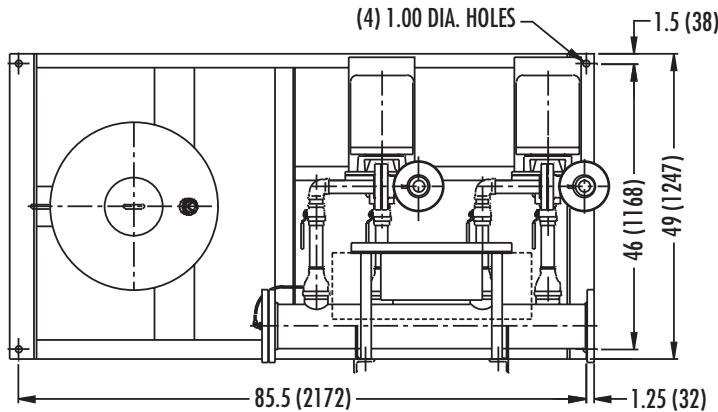

NOTES:

1. All dimensions in inches (mm) and may vary $\pm 1/2"$ (13).
2. Not for construction purposes unless certified.
4. Manifold flanges are ANSI Standard Class 125 Flat Face.
5. Standard (right hand) assembly is shown. Consult factory for other configurations.

MOTOR	AY MAX.
145JM	0
182JM	0
184JM	0
213JM	1.00
215JM	0.50
254JM	1.25
256JM	1.00
284JM	1.50
286JM	1.50

132-GALLON & 158-GALLON TANKS
ARE BASE MOUNTED. 220-GALLON
TANKS ARE NOT MOUNTED.

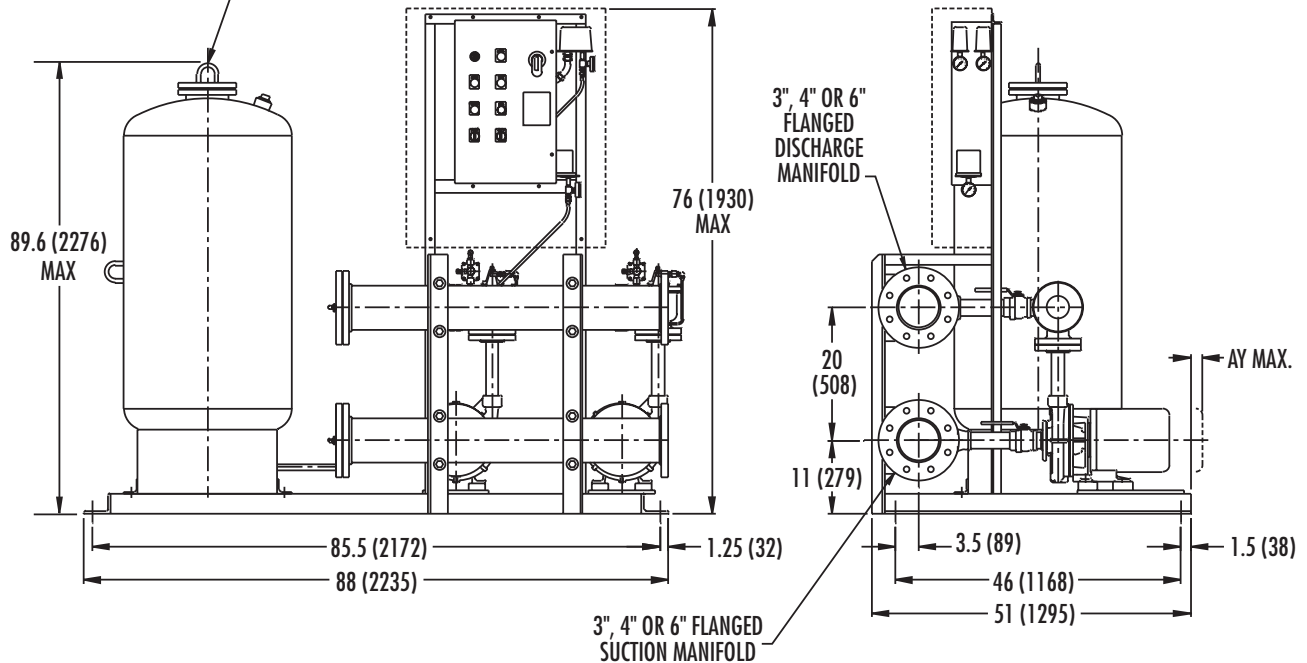

AURORA MODEL CP BOSS

HORIZONTAL TRIPLEX WITH BASE MOUNTED TANK

- NOTES:**
1. All dimensions in inches (mm) and may vary $\pm 1/2"$ (13).
 2. Not for construction purposes unless certified.
 3. Motor is shown in standard configuration.
 4. Manifold flanges are ANSI Standard Class 125 Flat Face.
 5. Standard (right hand) assembly is shown. Consult factory for other configurations.

MOTOR	AY MAX.
145JM	0
182JM	0
184JM	0
213JM	1.00
215JM	0.50
254JM	1.25
256JM	1.00
284JM	1.50
286JM	1.50

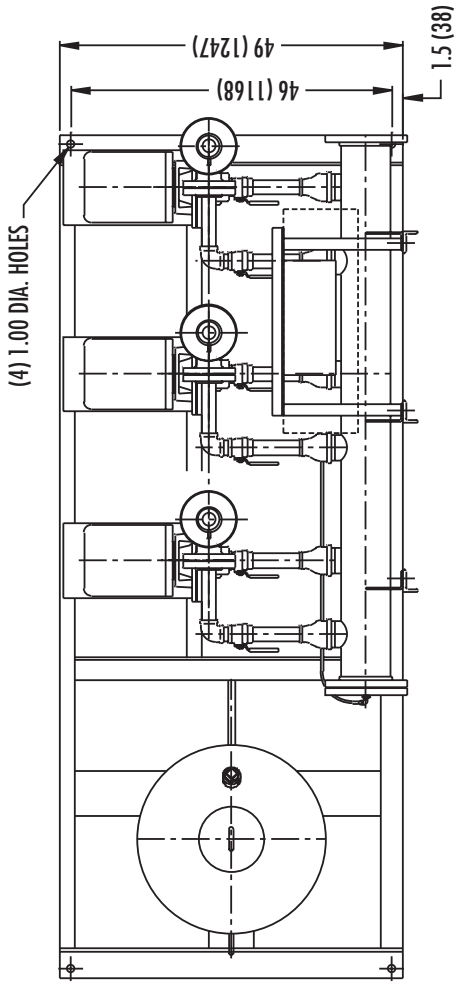

132-GALLON & 158-GALLON TANKS ARE BASE MOUNTED. 220-GALLON TANKS ARE NOT MOUNTED.

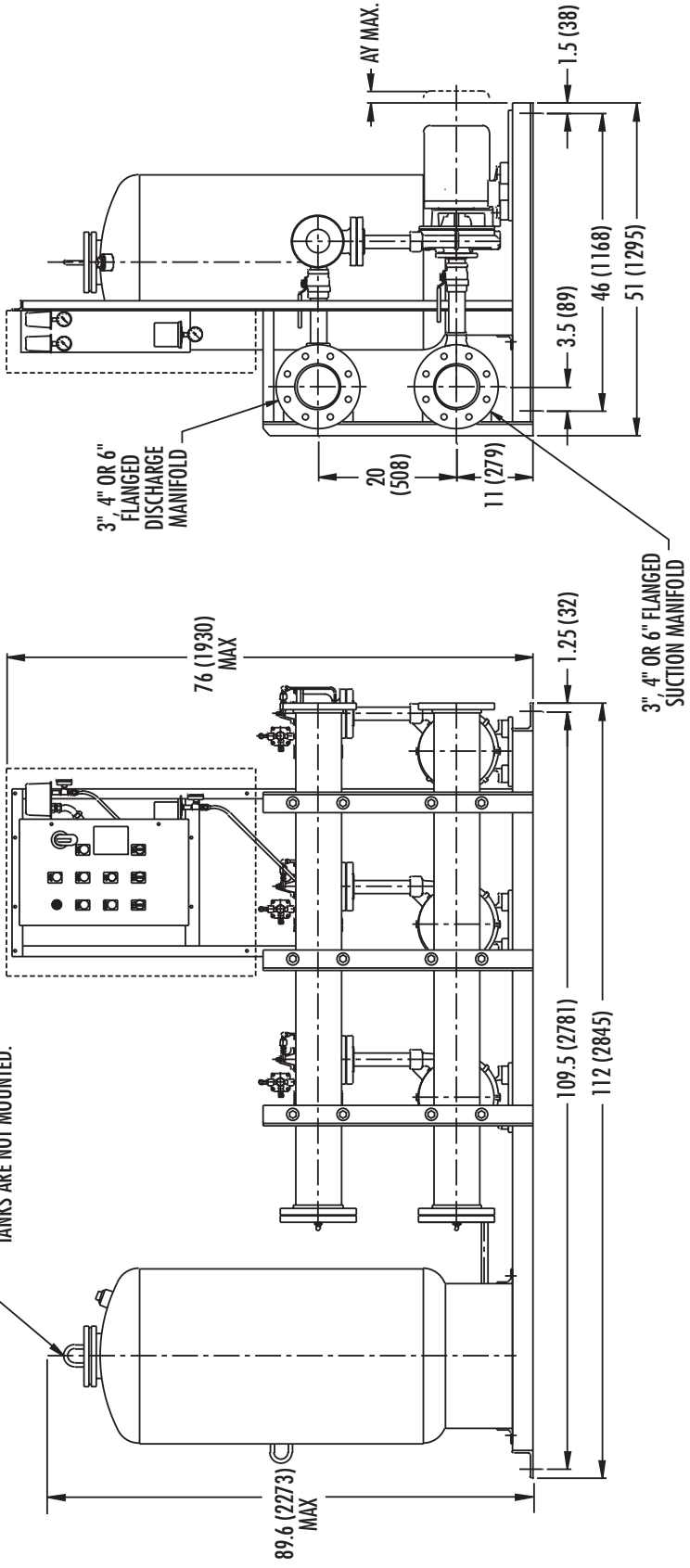

AURORA MODEL CP BOSS

VERTICAL DUPLEX WITH BASE MOUNTED TANK

Section **770** Page **207**

Date **January 2003**

Supersedes Section 770 Page 207
Dated August 2002

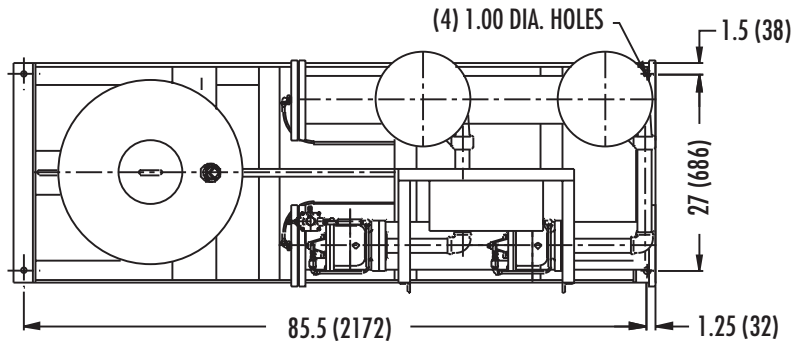

132-GALLON & 158-GALLON
TANKS ARE BASE MOUNTED.
220-GALLON TANKS
ARE NOT MOUNTED

NOTES:

1. All dimensions in inches (mm) and may vary $\pm 1/2"$ (13).
2. Not for construction purposes unless certified.
4. Manifold flanges are ANSI Standard Class 125 Flat Face.
5. Standard (right hand) assembly is shown. Consult factory for other configurations.

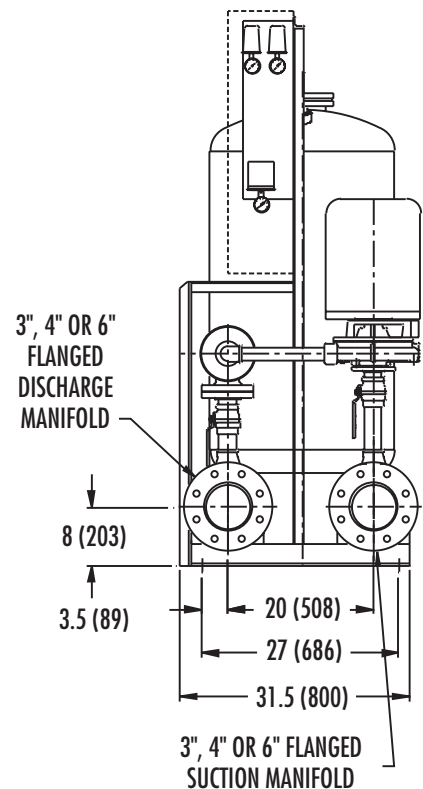
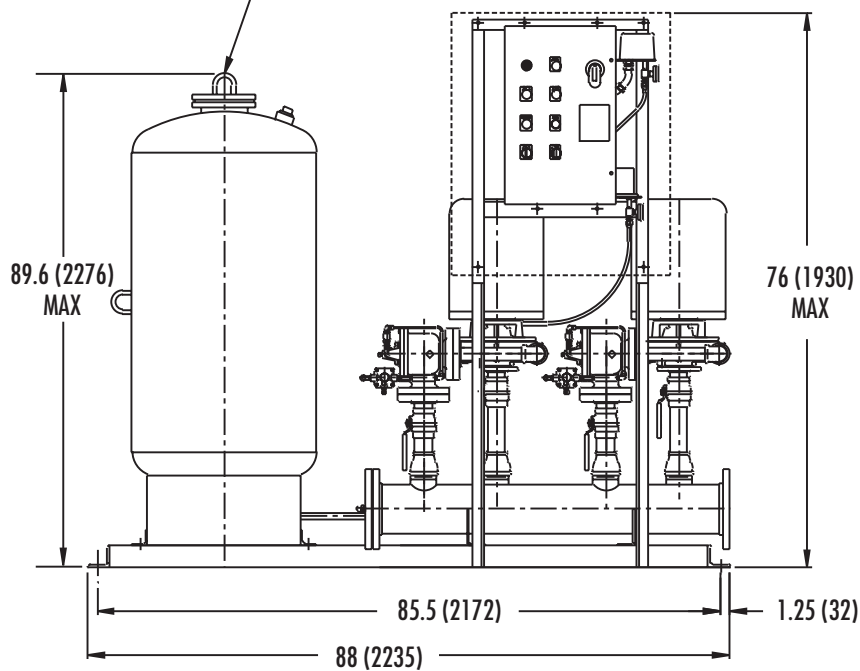

AURORA MODEL CP BOSS

VERTICAL TRIPLEX

WITH BASE MOUNTED TANK

- NOTES:**
1. All dimensions in inches (mm) and may vary $\pm 1/2"$ (13).
 2. Not for construction purposes unless certified.
 3. Manifold flanges are ANSI Standard Class 125 Flat Face.
 4. Standard (right hand) assembly is shown. Consult factory for other configurations.

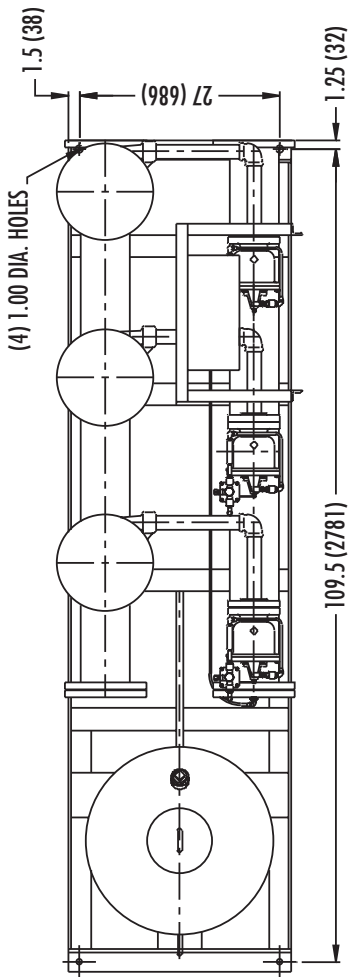

132-GALLON & 158-GALLON TANKS ARE BASE MOUNTED. 220-GALLON TANKS ARE NOT MOUNTED.

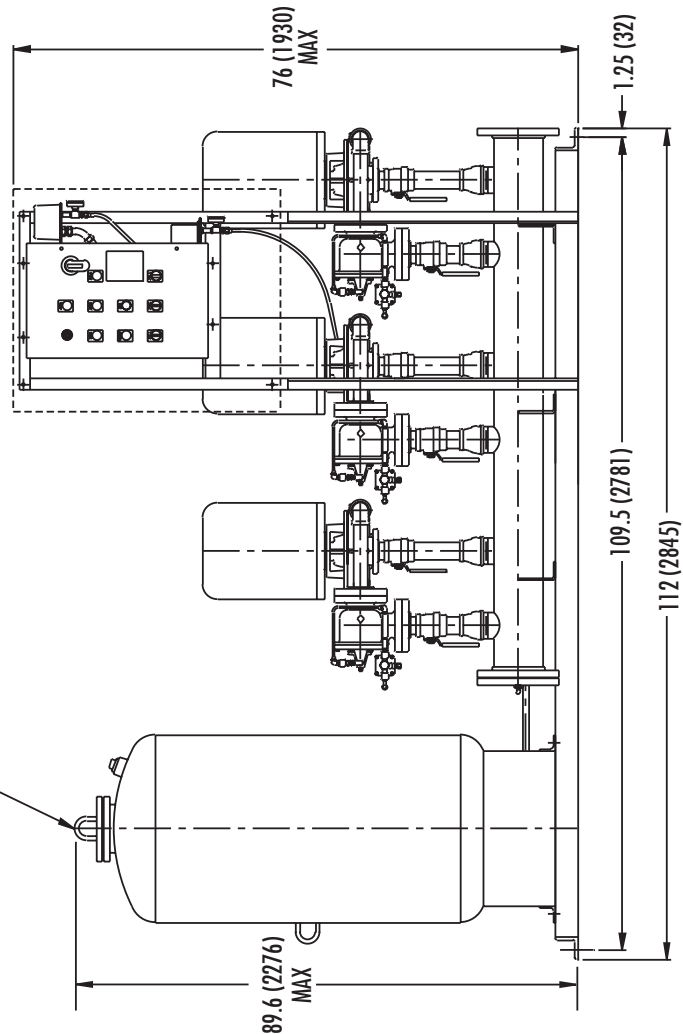
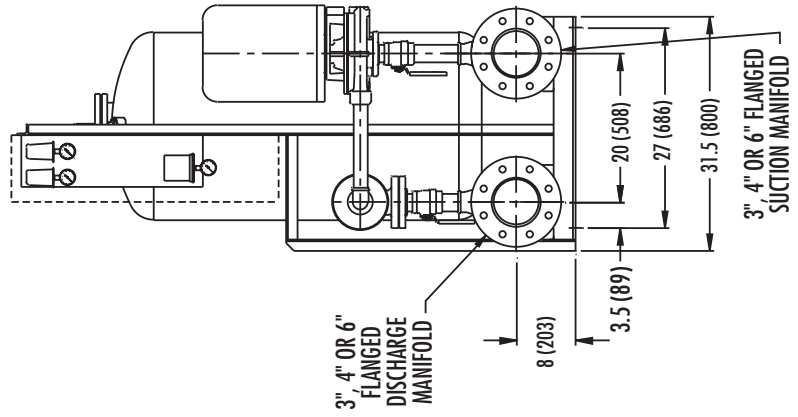

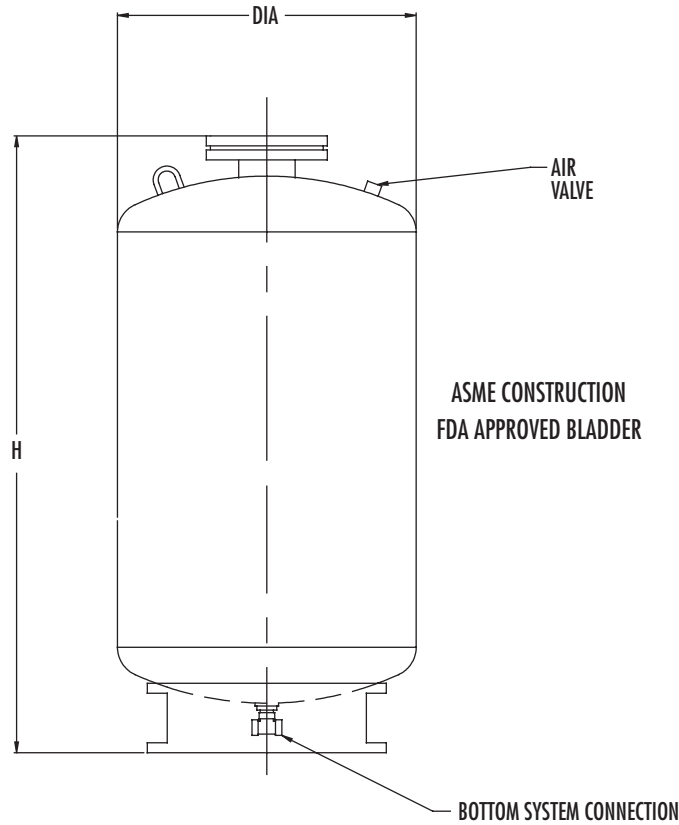

TANK WEIGHT AND SIZE				
TANK SIZE (GALLONS)	125 PSIG (LBS)	175 PSIG (LBS)	DIA (TYPICAL)	H (TYPICAL)
120 - 132	298	349	30 (762)	61 (1549)
158 - 165	400	480	30 (762)	80 (2032)
211 - 220	513	626	36 (914)	69 (1753)

NOTES:

1. All dimensions in inches (mm) and may vary $\pm 1/2"$ (13).
2. All dimensions and weights are approximate.
3. Not for construction purposes unless certified.
4. 211-220 gallon tanks cannot be mounted on base.

INSTRUCTION AND INSTALLATION MANUAL

MODELS 770, 790

BOOSTER SYSTEMS

2

ATTENTION: SAFETY WARNINGS:

Read and understand all warnings before installation or servicing pump.

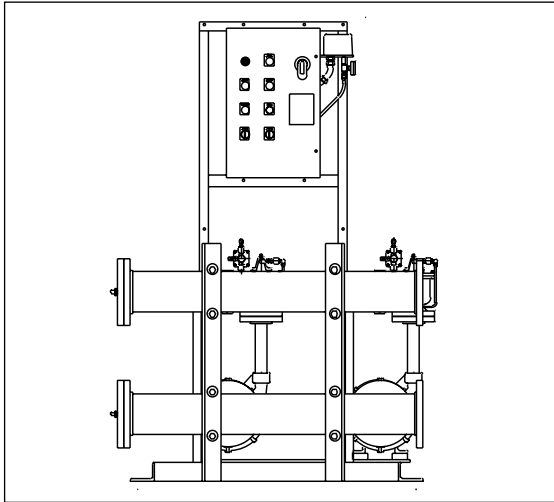

Standard 770 Duplex System with Horizontal Pumps

SYSTEM RECEIPT INSPECTION:

- Inspect system and components for signs of damage during shipment.
- Check system for missing parts.
- Check system for loose parts.

SYSTEM INSTALLATION:

- Mount and anchor system in properly prepared location.
 - Verify system is level and piping aligned with building system piping.
- Connect building piping to booster system, ensure no pipe stress is transferred to booster system.
- Ensure system disconnect switch is in the off position.
- Ensure pump H-O-A switches are in OFF.
- Have qualified electrician route power to system control panel.
- Grout system base using a "non-shrinking" grout.
- Route pump thermal relief valve discharges to appropriate floor drain.
- If system includes the optional, remote hydropneumatic tank, install tank in a suitable location and connect to booster system manifold.

CAUTION

Hydropneumatic tank is shipped from the factory with the isolation valve closed. Tank MUST be pre-charged to system pressure with air prior to opening isolation valve and admitting water.

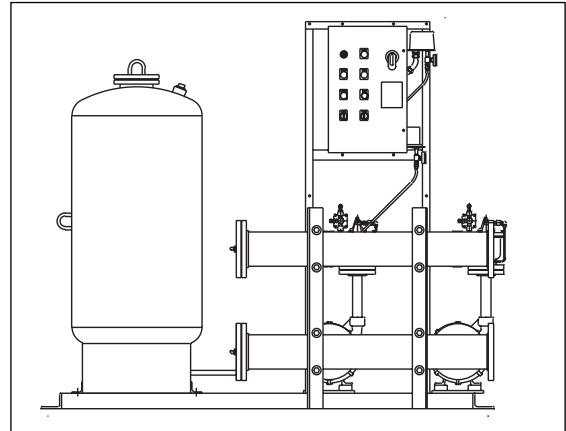

Standard 770 Duplex System with Horizontal Pumps

SYSTEM STARTUP:

- Open all system isolation valves.
- Slowly open booster system supply from building system.
- Open the petcocks on pumps and system manifolds to allow air to bleed from system.
- Turn booster control panel disconnect to ON.
- Jog pump motor #1 and observe direction of rotation. Take corrective action as required.
- Jog pump motor #2 and observe direction of rotation. Take corrective action as required.
- Turn pump #1 H-O-A switch to the hand position. Bleed air from the pressure reducing valve at the highest point on the valve by opening any fitting.
- Place pump #1 H-O-A switch to OFF.
- Turn Pump #2 H-O-A switch to the hand position. Bleed air from the pressure reducing valve at the highest point on the valve by opening any fitting.
- After all air is bled from the system, place system in operation by placing both pump H-O-A switches to AUTO.

OPERATION:

NOTE

Aurora booster systems are tested and adjusted at the factory prior to shipment. System pressure switches are factory adjusted to the specifications provided at time of order.

NOTE

Failure to properly vent system could result in erratic or sluggish operation due to air trapped in the system PRVs.

OPERATION (NO TANK):

When pump H-O-A switches are placed in AUTO, the lead pump will run continuously to maintain system pressure.

Check system suction pressure with pump #1 running. The low suction pressure switch is typically set at the factory at 5 psi OFF and 20 psi ON. The pressure switch setting can be changed as

MODELS 770-790

needed for the field condition. (See Controller Operation, Appendix A)

When flow demands increase beyond the pump design point the system pressure will begin to decrease.

The low system pressure switch is typically set at the factory at 10 psi below system pressure. The pressure switch setting can be changed as needed for the field conditions.

When system pressure reaches the pre-determined set point, the lag pump starts in response to the lower pressure. The lag pump will run as required until flow demand decreases and system pressure rises above the set point. When system pressure reaches the set point the lag pump will shutdown automatically and the lead pump will continue to run. During periods of low system demand/shutoff operation both pumps are provided with a thermal relief valve for protection. (See Controller Operation, Appendix A)

OPERATION (WITH OPTIONAL TANK):

When pump H-O-A switches are placed in AUTO, the tank pressure switch sequences the lead pump under no flow condition. The tank fills to its capacity and tank pressure starts to build up. This increase in tank pressure will stop the lead pump when the pre-determined set point is reached and after the minimum run time is satisfied. The tank will supply all "leak" loads. As tank pressure drops due to further system demands the lead pump will start after a time delay. The tank switch will continue to cycle the lead pump off and on as required to maintain tank/system pressure.

NOTE

Tank pressure switch high set point must be lower than the pump shutoff head.

Set the tank pressure switch high set point 5 psi above system pressure. Set the tank pressure switch low set point to normal system pressure.

Check system suction pressure with pump #1 running. The low suction pressure switch is typically set at the factory at 5 psi OFF and 20 psi ON. The pressure switch setting can be changed as needed for the field condition. (See Controller Operation, Appendix A)

With the lead pump running if the system pressure continues to fall due to flow demands the lag pump will start and run with the lead pump until the system demand is satisfied and the minimum run time setting is met. Pumps stop in the reverse order.

The low system pressure switch is typically set at the factory at 10 psi below system pressure. The pressure switch setting can be changed as needed for the field conditions.

In the event of tank pressure switch failure both pumps are provided with a thermal relief valve for protection.

APPENDIX A

APPLICATION:

Standard (Typical) Systems: These controllers are used to control one or more pump motors. On multiple pump installations, the pumps may be equal in size (horsepower) or may be different sizes. The most common systems are duplex systems with one small and one larger pump and triplex systems with one small and two larger motors, where the larger motors are typically of the same size. In standard units where one pump is smaller than the other(s) it is meant to run continuously. If it is in a duplex system, the pumps won't be alternated from Lead to Lag.

Alternation schemes:

Equal Size Pumps:

Yes for Duplex (both), and Triplex (all three).

Unequal Size Pumps:

No for Duplex, Yes for Triplex (Pumps #2 and #3). Pump #1 (the smaller pump) runs continuously.

Pressure Regulated Systems: Standard systems utilize a pressure regulating valve (PRV) for each pump. The pump motor controller responds to the system pressure to start and stop (control) the pump or pumps. When the system pressure drops below a preset amount, usually just below the PRV setting(s), the controller causes the next pump to start. When the pressure rises sufficiently, the controller stops the last pump started, usu-

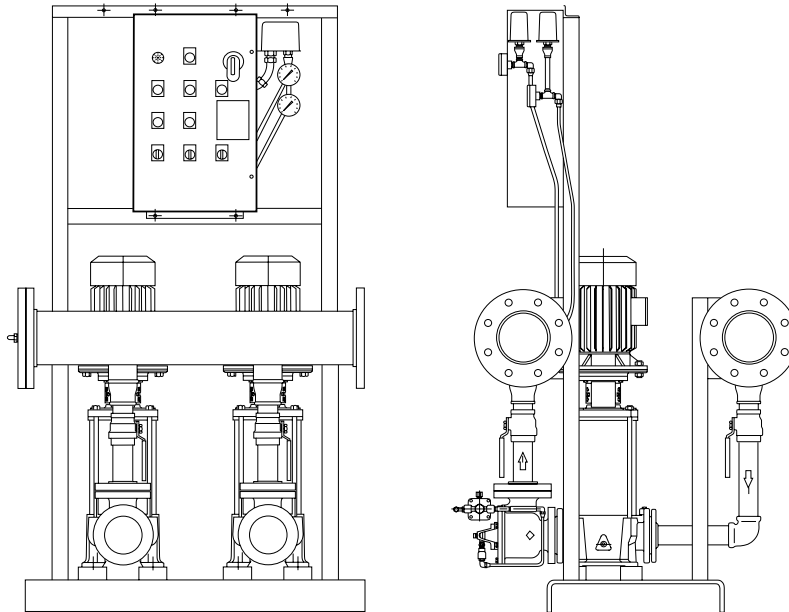

Standard 790 Packaged System

APPENDIX A (continued) MODELS 770-790

ally after a minimum running interval. A low pressure alarm and shutdown is included in standard systems to protect the pump(s) from running dry or cavitating on absent or low inlet pressure.

OPTIONAL SYSTEMS

Pressure Transducer Systems: The controller uses a solid state pressure transducer to control the operation (starting and stopping) of the motor(s). This takes the place of the System Pressure Switch. The transducer signal is connected to the PLC which has programmable start and stop set points. When the system pressure drops below the preset pressure, usually just below the PRV setting(s), the controller causes the next pump to start. Rising pressure causes the controller to cycle the pump(s) off.

Pressure Tank Systems: The booster pump system (package) may include an optional pressure tank to improve system performance. In this case the controller responds to pressure in the tank to maintain the tank pressure at a level above the system pressure in order to provide adequate pressure to the pressure regulating valve or valves. When the pressure rises sufficiently, the controller stops the last pump started, normally after a minimum running interval.

SEQUENCE OF OPERATION

General: These units control one or more booster pump motors to maintain the pressure in a system within a selected range. This is accomplished with a pressure switch which has a fixed differential (4 lbs @ 100psi). Refer to the wiring or schematic diagram for details. Standard units have one or more motor starters, a Control Power Transformer (CPT) and secondary and dual primary fuses for same. Standard units include a PLC for logic sequencing, timing and control. Standard units also include an audible alarm, which can be silenced, and one or more visual alarm lights. The standard unit also includes one or more Pump Running signal lights, L2 & etc.

Power Wiring: The input lines (mains) connect to the top of the Disconnect Switch (DS) or Circuit Breaker CB. Power flows through the short circuit protection motor Line (Mains) Fuses 1F & etc., or Circuit Breaker CB, and then to the Motor Starter, which is horsepower rated. The Motor Starter consists of Motor Contactor (1M & etc.) and Overload Relay OL-1 & etc.. When the Motor Contactor Coil 1M, or etc., is energized, Motor Contactor 1M contacts close to feed power through the Overload Relay to its output terminals where the motor is connected. This energizes the motor to start the pump.

Control Transformer: Control power is supplied by a Control Power Transformer (CPT). Its primary is supplied by two primary side line fuses. The secondary output of the transformer is protected by a secondary fuse. See the controller Schematic Diagram for the fuse designations. Secondary control power is 115 Vac (110 - 120 Vac) at 50 or 60 Hz depending on the line (mains) frequency. Secondary power is used for the motor contactor coils, indicator (pilot) lights, audible alarm, the PLC and any additional control relays or components.

Overload Relay: The Overload Relay furnished in the motor starter provide protection from excessive currents. The overload relay has been sized and set to trip open when the motor exceeds 125% of the Full Load Current (FLA) multiplied by the rated Service Factor (SF). Trip times vary depending on the magnitude of the current overload, the number of previous starts, the ambient temperature of the controller, and the size of

the overload element. Briefly, the Overload Relay is sized to allow initial starting currents while protecting the motor from excessive long starting currents or excessive running currents. (See Installation Instructions - Protection for proper sizing).

Power Available Light: A Power Available pilot light (L1) indicates then the disconnect switch (DS) or main circuit breaker is closed, and when power is supplied to the unit and when the CPT primary and secondary fuses are not blown.

Warning:

Use care when using the MANUAL (MAN) position of the control switch to avoid causing system Over Pressure.

Control Selector Switch: One selector switch, HOA-1 & etc., is included for each motor. The switch includes a "MAN" (Manual, Hand) position, an "OFF"(Safety) position, and an "AUTO" (Automatic Control) position. In the manual position, the Pressure Switch and all automatic control is bypassed so the contactor coil is continuously energized by the selector switch. The Overload Relay contacts also override the manual position to protect the motor.

"OFF" (Safety) Position: In the "OFF" position, the Motor Contactor coil is de-energized to prevent the motor from running.

Warning:

Use care when using the MANUAL (MAN) position of the control switch to avoid causing system Over Pressure.

"MAN" Position (Manual Control): Control power wiring is tapped off the incoming power on the load (down-stream) side of the Line Fuses or Circuit Breaker. It is routed to the three position (Auto-Off-Manual) selector switch. In the manual position, the all pressure switches and all automatic control is bypassed so the contactor coil is continuously energized by the selector switch. The Overload Relay contacts also override the manual position to protect the motor. The Minimum Run Timer does not operate with the selector switch in the MANUAL position.

"AUTO" (Automatic Control) Position: In this position, the motor starter is connected to the appropriate output terminal of the PLC (Programmable Logic Controller) which enables automatic control of the pump motor by the PLC. Note that overload relay operation is independent of the PLC or any other control circuitry to protect the motor.

Motor Running Light(s): The Pump 1 Running light activates when ever the motor contactor (starter) for Motor No. 1 is closed under either manual or automatic control.

AUTOMATIC (PLC) CONTROL

Alarm Circuit: The standard unit includes alarm circuitry to annunciate failure or fault conditions. The standard alarm condition is Low Suction Pressure as sensed by the Low Suction

APPENDIX A (continued) MODELS 770-790

Pressure switch (PS-1). When the pressure drops to less than the trip setting of this pressure switch, its contacts close. This signals the PLC that the condition has occurred. The PLC activates the Low Suction Audible Alarm. The standard audible device is a solid state (Sonalert) annunciator. The PLC also activates a Low Suction alarm signal light. The alarm can be silenced by momentarily operating the Alarm Silence switch (SW-1) which signals the PLC to de-activate the audible alarm. The alarm light stays lit until the Low Suction Pressure switch resets. The alarm circuit resets itself and re-activates on the next occurrence of low suction pressure.

General: In the AUTO position, motor operation is under the control of the PLC. The PLC utilizes an internally stored program to control the operation (starting and stopping) of the motor. The PLC responds to the Low Suction Pressure switch and to System Pressure Switch as a minimum. The PLC program also includes various timing functions as outlined below.

Pressure Sensing: The standard unit is pressure controlled by sensing either the system pressure or by sensing the pressure in a tank, if supplied. Multiple pump systems (Duplex & Triplex) may employ equal size pumps or one pump may be smaller than the others.

Alternation: The standard system employs one smaller pump and one or more larger pumps. If there is more than one larger pump (Triplex) they are usually equal in size to one another. The small pump is meant to run continuously. The controller cycles the larger pump or pumps as needed to maintain system pressure. Alternation of the pumps is not used in Duplex systems of this type. The smaller pump which runs continuously is considered the "Lead" pump and the other pump or pumps are considered the "Lag" pump or pumps.

When all pumps are of the same size, a duplex controller may be set up to alternate which of the two, or more) pumps operates as the Lead pump and which pump or pumps operates as the Lag pump or pumps.

Minimum Run Timing: The standard unit includes timers to control the Minimum Running time of the pump or pumps to prevent short cycling of the pump motor(s). This avoids overheating the motors which can occur if they are started too frequently. This allows the motor fan to cool down the motor windings from the last start before the pump is shut down.

Restart Delay Timing: The Restart delay prevents starting a pump which is still spinning down from the last running. This can occur when the demand is less than needed for the pump but more than what can be supplied by the other pump(s). In this case, when the pump shuts down, the pressure can drop rapidly enough to immediately signal the pump to start again. If the pump is still spinning, this can cause mechanical shock to the pump and motor and can also cause large spikes (momentarily large transient) currents which can blow fuses or trip circuit breakers. This occurs when the motor magnetic flux vector angle is out of phase with the power line phase angle by large enough difference. The Restart delay lets the motor come to rest or near rest which also allows the motor magnetic flux to decay. In this state, the motor can be safely restarted with out excessive transients and mechanical shock.

Alternation Times: Note: The Alternation Times apply only to controllers for two or more motors (Duplex & Triplex). The Alternation Time is the clock time that must elapse before the PLC changes the pump from being a Leading pump into a Lagging pump. The Alternation Times are independent of the

motor actual running time.

Alternator Overlap Time: When one or more pumps are not running, alternating the pumps can cause a momentary pressure drop when the running pump spins down before the other pump comes up to full speed. The overlap timer is an over run timer that causes a delay before the pump is shut down. This allows the second pump to come up to full speed while the first pump continues to run. After a typical setting of a few seconds, the controller shuts down the first pump if it is not needed for the system demand.

CONTROLLER SET-UP AND ADJUSTMENTS

Preliminary Steps: Before attempting to adjust the pressure switch in pressure controlled systems, adjust the pump pressure regulating valves for the desired system pressure(s). Remove the covers from the pressure switch(s). A system pressure gauge is required for setting the System Pressure Switch.



Warning: Shock Hazard

Some settings require observing or adjusting PLC settings and LED indicators. Use Caution to avoid contact with any electrical terminals, fuses, or connections to avoid electrical shock.

Timer (TIM) Settings: Note: Changing the timers requires one of three procedures. 1) The times are set at the factory using a lap-top computer with the appropriate program and communications cable, or 2) an optional memory chip can be programmed at the factory for the new times and added to the PLC in question, or 3) an HMI display and setting module can be installed onto the PLC for the purpose of changing the timer settings. Contact the factory for details on how this module is used. All timer settings are in seconds. The standard timers are factory set at the following settings:

$T0 + T9 = \text{Alternation Time on Pump \# 2} = 24\text{hr.}$
(Note: $T0(65535\text{sec}) + T9(20865\text{sec}) = 86400 \text{ seconds} = 24 \text{ Hours}$)
 $T1 + T10 = \text{Alternation Time on Pump \# 1} = 24\text{hr.}$
(Note: $T1(65535\text{sec}) + T10(20865\text{sec}) = 86400 \text{ seconds} = 24 \text{ Hours}$)
 $T3 = \text{System Pressure Start Delay} = 2 \text{ Seconds.}$
(Motor Restart Delay)
 $T4 = \text{Pump \# 1 Alternation Overlap Time} = 5 \text{ Seconds.}$
(Pump Over-run Timer)
 $T5 = \text{System Pressure Minimum Run Time} = 4 \text{ Minutes.}$
 $T6 = \text{Pump \# 2 Alternation Overlap Time} = 5 \text{ Seconds.}$
(Pump Over-run Timer)

Low Pressure (Cut-Off) Pressure Switch: Set the pressure switch to the desired cut-off pressure as indicated on the indicator dial. One example of a setting for a booster pump drawing suction from a municipal main would be 20 to 30 psi for the trip point of this switch.

Pressure Switch Set-up: To set the System Pressure switch (PS-2) remove its cover. Start the (lead) pump manually ("MAN" position) and modulate the system flow until the pressure drops just below the desired set point. Adjust the pressure switch On (Start) adjustment until the Input I-0 LED on the PLC lights. Set the pressure switch Off (Stop) setting as close as practical to the On setting. Typical settings on a 100 PSI nominal system would be trip (start) at 98 psi and reset at 102 psi. Verify the settings by modulating the system flow and observe when the PLC Input I-0 LED actuates and extinguishes.

APPENDIX A (continued) MODELS 770-790

REPLACEMENT PARTS LIST

<u>SYMBOL</u>	<u>PART NO.</u>	<u>DESCRIPTION</u>	<u>NOTES</u>
DS	302400	Disconnect Switch, 600 Vac, 30/40 Amp	(Internal Switch only)
DS	302401	Disconnect Switch, 600 Vac, 60/80 Amp	(Internal Switch only)
DS	302402	Disconnect Switch, 600 Vac, 100 Amp	(Internal Switch only)
---	400939	Disconnect Switch Handle Operator only,	(30 thru 100 Amp)
HOA	401199	Auto-Off-Manual Selector Switch	
---	401992	Contact Block (N.O.)	
PS*	305420	Standard Pressure Switch	
PS4	305421	Tank Pressure Switch	
PLC	305580	Programmable Logic Controller	(standard units only)
---	305040	Control Power Transformer, 50 VA, 208/240/460 Vac	
---	305041	Control Power Transformer, 50 VA, 208/380/575 Vac	

Note: One or more renewal parts such as fuses, heaters, contacts, and etc. may be obtained from local electrical distributor(s).

IMPORTANT: When ordering replacement parts, be sure to specify the complete MODEL NUMBER and SERIAL NUMBER of controller in which they are to be used.

SERVICE AND ASSISTANCE:

Contact either the Aurora Pump field agent or Factory customer Service for assistance. The factory can be contacted at the address and numbers show below.

Aurora Pump
800 Airport Road
North Aurora, IL 60542 USA

Phone: 630-859-7000 Fax: 630-859-7034
Web Page: <http://www.aurorapump.com>
Email: aurora_info@pentairpump.com

APPENDIX A (continued) MODELS 770-790

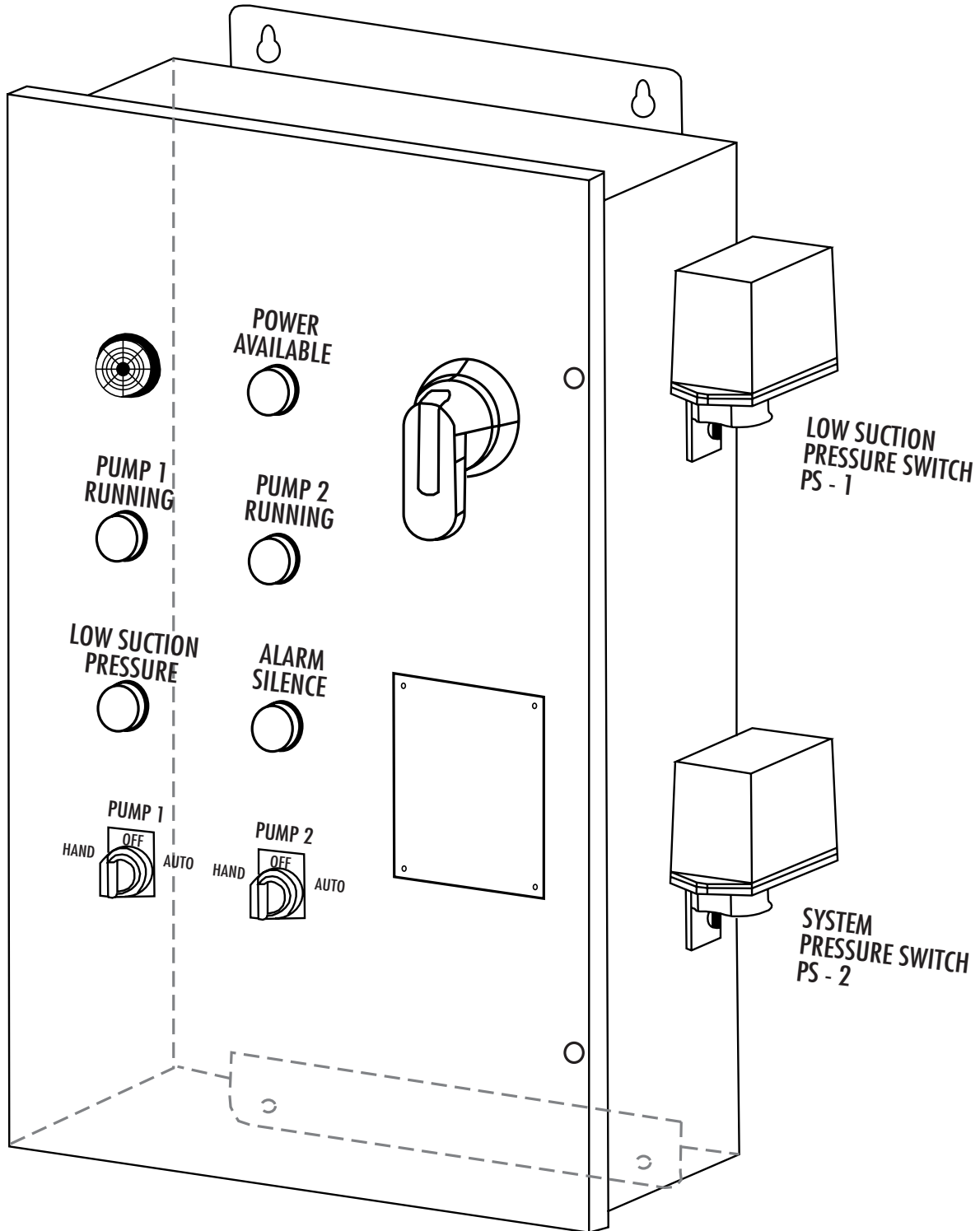

Notes:

- Enclosure: 16 Gauge Sheet Steel
- Finish: Grey Baked Enamel
- Application: For Indoor Use. NEMA 1
- Mounting: Wall Mount
- Max. Shipping Weight: 42 lbs. (20kg)

APPENDIX A (continued) MODELS 770-790

1
2
3
4
5
6
7
8
9
10
11
12
13
14
15
16
17
18
19
20
21
22
23
24
25
26
27
28
29
30
31
32
33
34
35
36
37
38
39
40
41
42
43
44
45
46
47
48

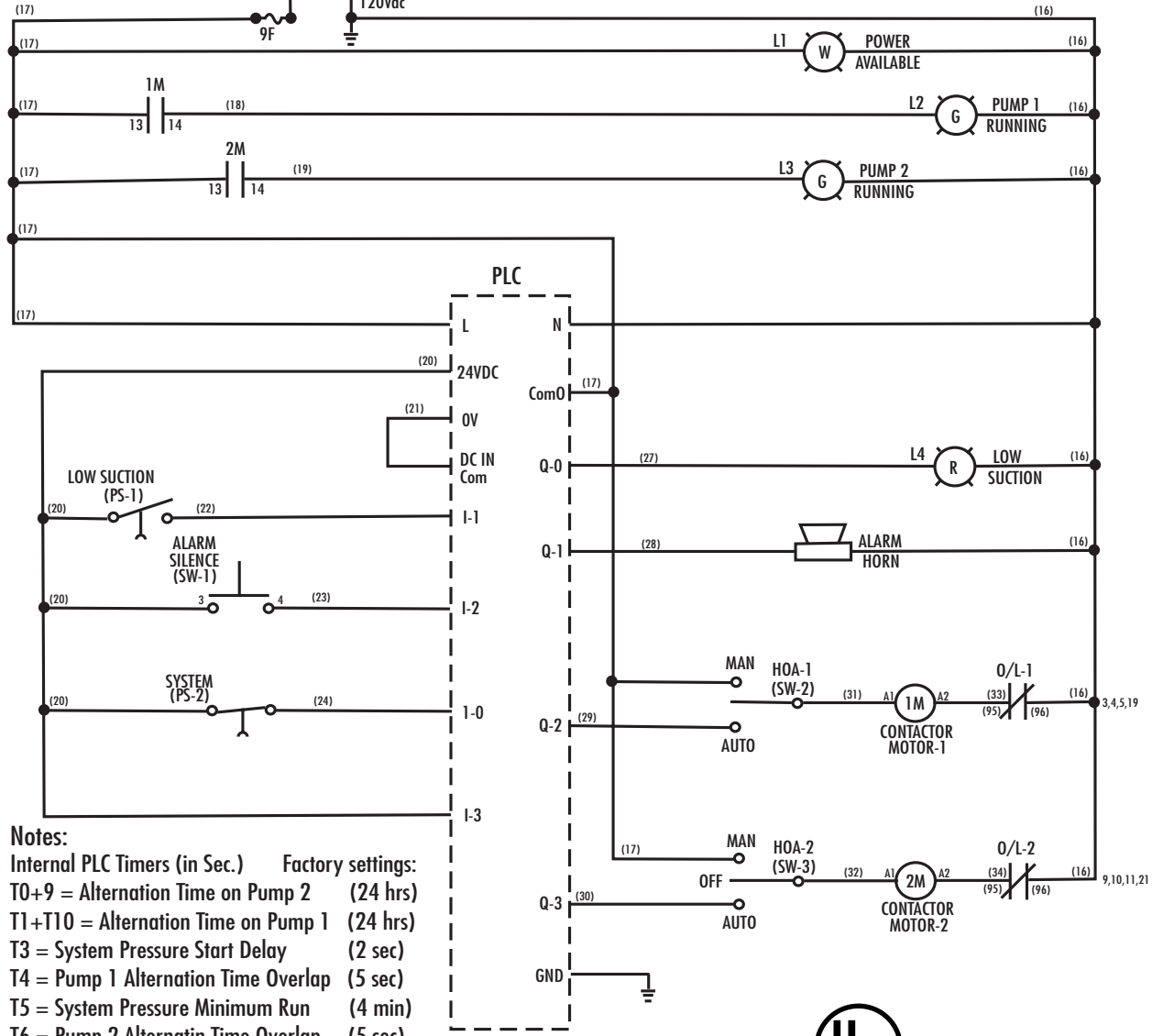
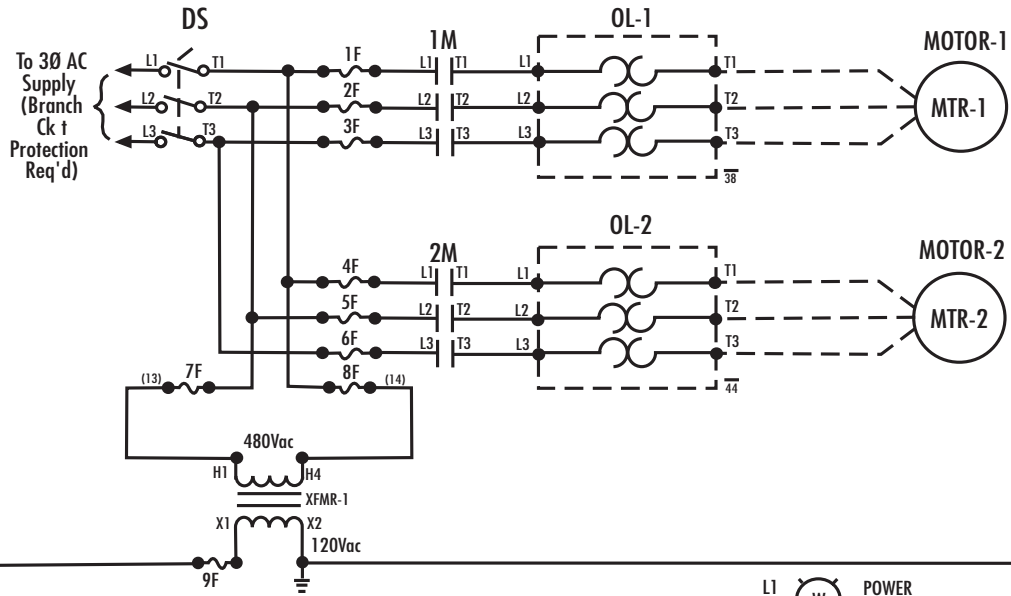

Notes:
 Internal PLC Timers (in Sec.) Factory settings:
 T0+9 = Alternation Time on Pump 2 (24 hrs)
 T1+T10 = Alternation Time on Pump 1 (24 hrs)
 T3 = System Pressure Start Delay (2 sec)
 T4 = Pump 1 Alternation Time Overlap (5 sec)
 T5 = System Pressure Minimum Run (4 min)
 T6 = Pump 2 Alternatin Time Overlap (5 sec)



APPENDIX A (continued) MODELS 770-790

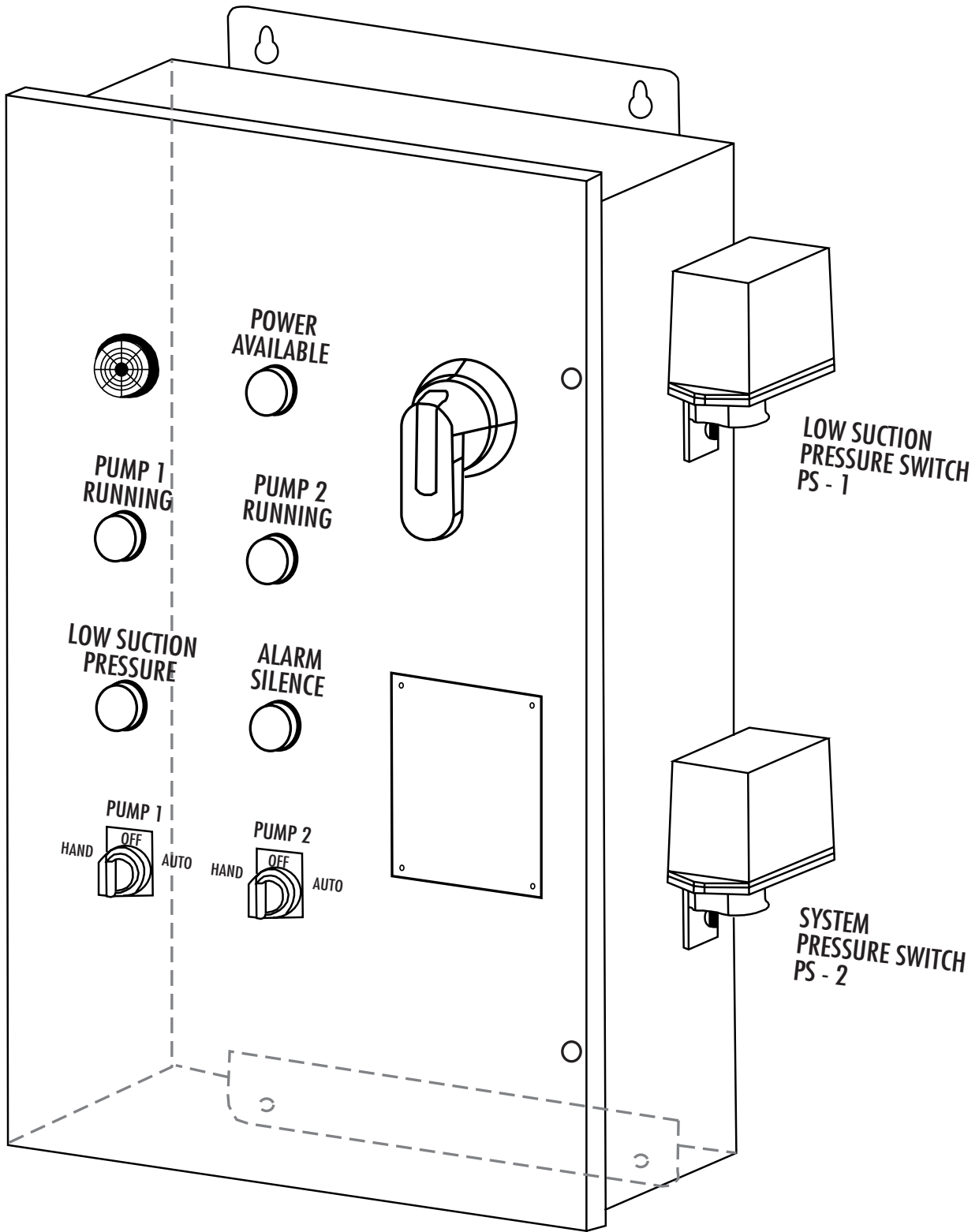

Notes:

- Enclosure: 16 Guage Sheet Steel
- Finish: Grey Baked Enamel
- Application: For Indoor Use. NEMA 1
- Mounting: Wall Mount
- Max. Shipping Weight: 42 lbs. (20kg)

APPENDIX A (continued) MODELS 770-790

1
2
3
4
5
6
7
8
9
10
11
12
13
14
15
16
17
18
19
20
21
22
23
24
25
26
27
28
29
30
31
32
33
34
35
36
37
38
39
40
41
42
43
44
45
46
47
48

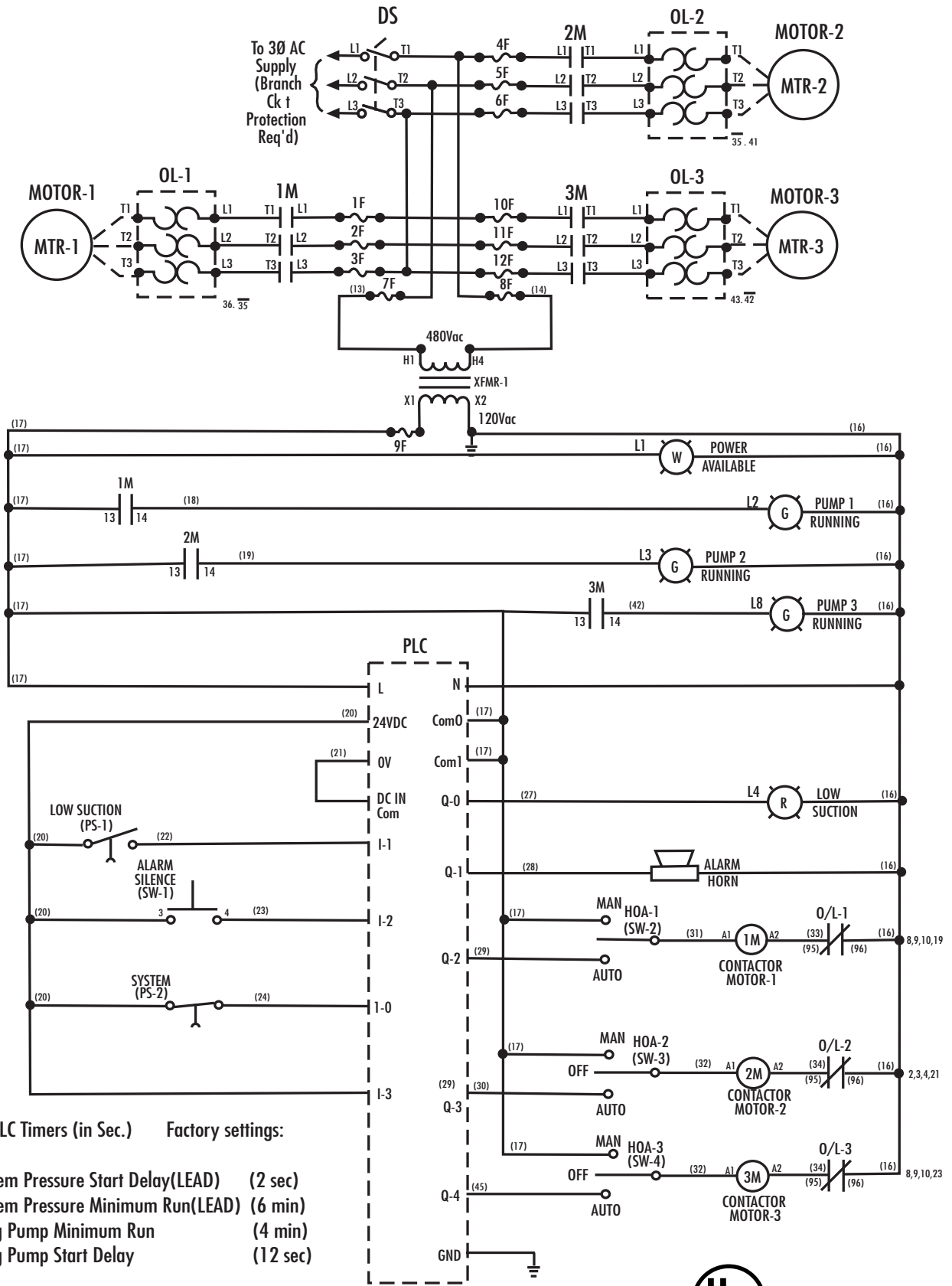

Notes:
Internal PLC Timers (in Sec.) Factory settings:
 T3 = System Pressure Start Delay(LEAD) (2 sec)
 T5 = System Pressure Minimum Run(LEAD) (6 min)
 T11 = Lag Pump Minimum Run (4 min)
 T12 = Lag Pump Start Delay (12 sec)



Option G

CIRCUIT BREAKERS IN PLACE OF LINE FUSES

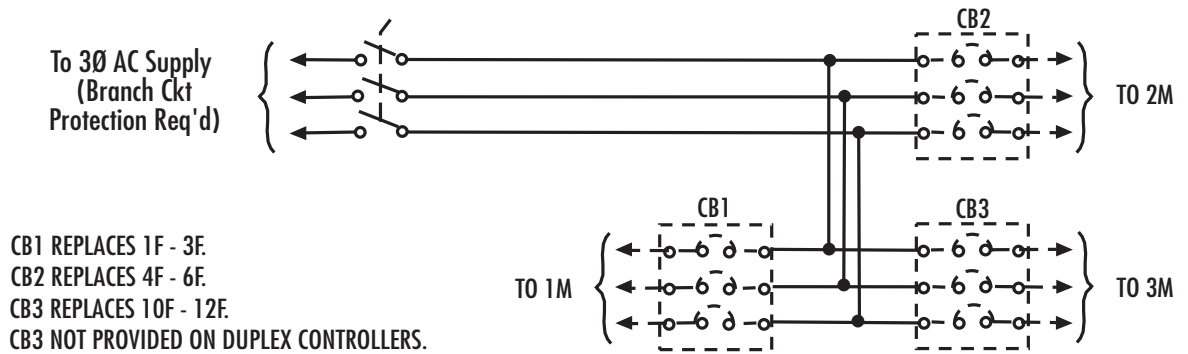

Option T

TANK PRESSURE SWITCH

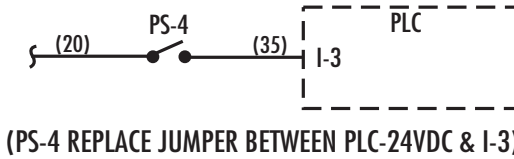

Option W

ELAPSED TIME METER

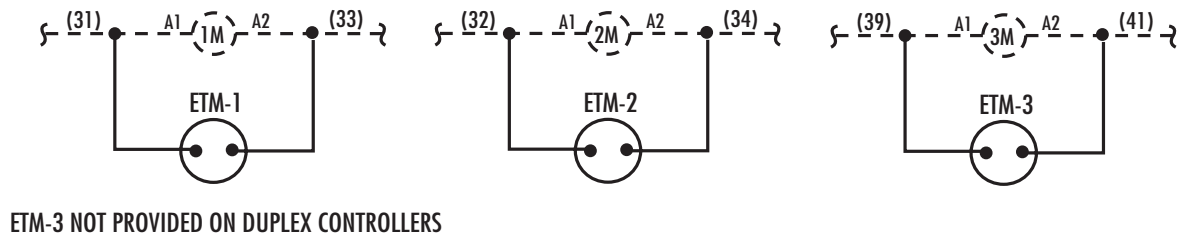

Option A

HIGH SYSTEM PRESSURE SWITCH, LIGHT AND ALARM

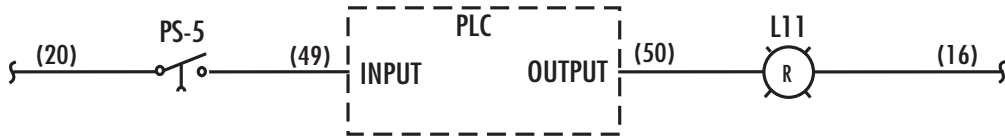

Option B

HIGH SUCTION PRESSURE SWITCH, LIGHT AND ALARM

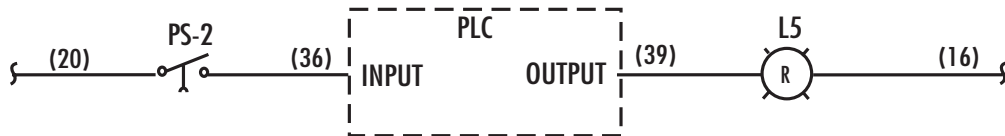

Option C

LOW SYSTEM PRESSURE SWITCH, LIGHT AND ALARM

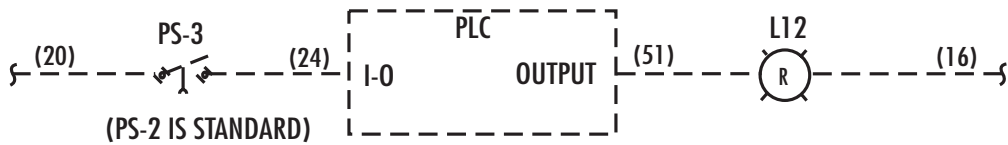

Option E

OVERLOAD TRIP, LIGHT AND ALARM

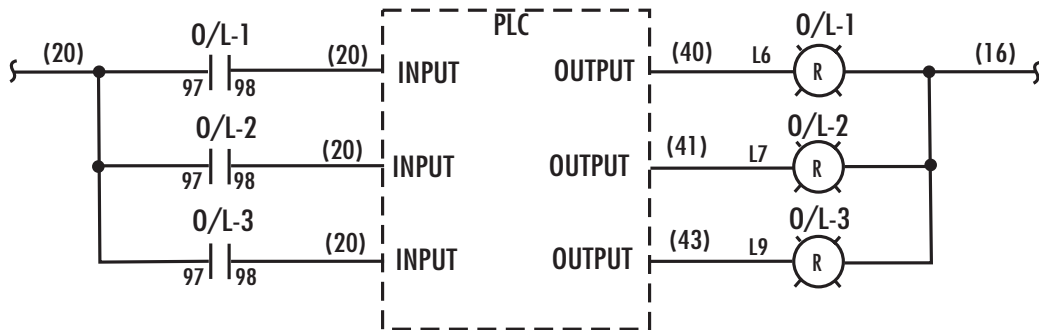

O/L-3 NOT PROVIDED ON DUPLEX CONTROLLERS

NOTE:

ALARM HORN AND SILENCE BB. SHOWN ON MAIN SCHEMATIC

APPENDIX B MODELS 770-790

MODEL	STOCK NO.	NO. OF CONTACTS	PRESSURE RANGE	PRESSURE CONNECTION
IPS40-1	9000104	1	10-175 PSI	NYLON 1/2" NPT MALE

UL LISTED and CSA Approved

Dimensions: 4-3/4"W x 2-1/4"D x 4-3/8"H

Enclosure: NEMA Type 4 for indoor or outdoor use. Cover – Die-cast with textured gray powdercoat finish. Base – Plated Steel with one opening for 1/2" conduit

Pressure Connection: 1/2" NPT Male

Differential Approx. (Not Adj.):

2 lbs. at 20 PSI; 5 lbs. at 175 PSI

Adjustable Range: 10-175 PSI

Maximum Pressure: 250 PSI

Switch Contacts:

One or two Snap Action SPDT (Form C Contacts)

15.0 Amps at 125/250 VAC

0.5 Amps at 125 VDC

0.25 Amps at 250 VDC

Pilot duty Rating: 125 VA 120/240 VAC

Ambient Temperature range:

-40°.180°F (-40°/82°C)

Media Temperature range:

32°/250°F (0°/121°C)

CAUTION

This device is not intended for applications in explosive environments.

The Model IPS pressure switches are designed to indicate an increase or decrease in normal system pressure. On the two switch models the two switches operate independently of each other and each switch may be adjusted to actuate at any point

within their adjustable range. They are designed for applications sensing air, water or any fluid or gas not harmful to nylon or silicone.

They are not designed to be used with any fluid or gas classified as hazardous.

NOTE

To prevent leakage, apply Teflon tape sealant to male threads only.

⚠ **Warning:**

Use of pipe joint cement may result in obstruction of aperture and loss of signal.

MOUNTING:

Device should be mounted in upright position. (Threaded connection down.)

FIELD ADJUSTMENTS:

The operating point of the switch or switches can be adjusted to any point within their adjustable range. (10-175 PSI). To adjust the device, turn the adjustment knob(s) clockwise to raise the actuation point and counterclockwise to lower the actuation point. On the two switch models the two switches operate independently of each other and each switch may be adjusted to actuate at any point within their adjustable range. The pressure scales on the devices are approximate. Final adjustment should be made with a pressure gauge.

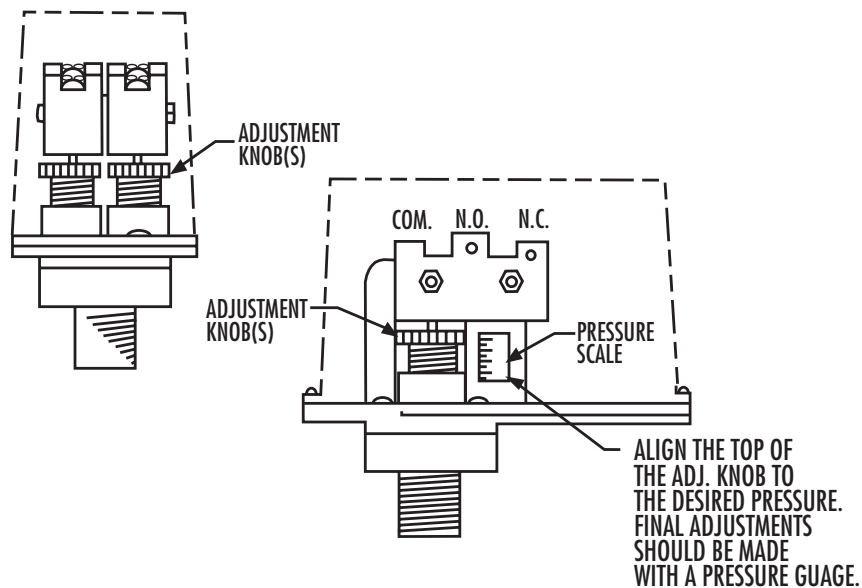

APPENDIX C MODELS 770-790

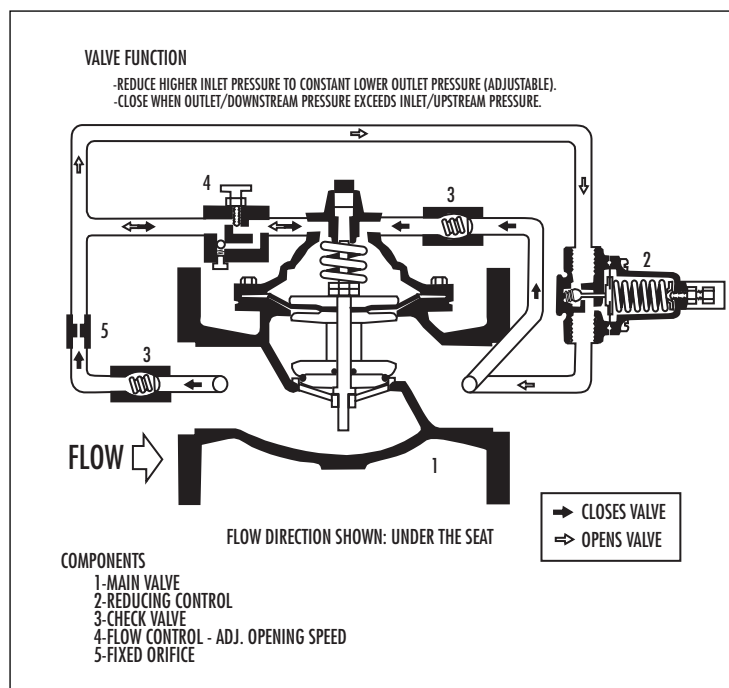

FUNCTIONAL DESCRIPTION

Pressure Reducing Function

The pressure reducing function is controlled by the 263AP or 263SS control. The 263 is normally open, adjustable control set to respond to outlet/downstream pressure changes. An increase in pressure above the set point of the control throttles the control towards closed. The main valve modulates towards a closed position. When pressure drops, the control throttles towards open, modulating the main valve towards an open position. A constant outlet/downstream pressure is maintained.

Turning the adjustment screw clockwise (IN) increases the outlet/downstream pressure, counterclockwise (OUT) decreases the outlet/downstream pressure.

Opening Speed Control – F.C.

An adjustable flow control adjacent the valve cover port, determines the opening speed of the main valve. It allows free flow into the cover and restricted flow out of the cover. Counterclockwise adjustment for faster opening, clockwise for slower opening. Complete closure prevents the main valve from opening.

Hydraulic Check Feature

When main valve outlet pressure exceeds inlet pressure, fluid is directed from the outlet to the main valve cover. This causes the main valve to close until inlet pressure / flow is again greater than outlet.

Main Valve – Description

CP-Boss automatic control valves are hydraulically operated, diaphragm actuated, pilot controlled, angle valves of packless design. The stem assembly is the only moving part in the main valve and is guided top and bottom. Positive, drip-tight, closure is accomplished by a quad seal and non-edged seat.

Start-Up and Adjustment

Close upstream and downstream isolation valves.

Open any ball valves or isolation cocks in the control tubing. Failure to open these will prevent the valve from functioning properly.

Step 1

Pre-set pilots as noted:

Pressure Reducing – Adjust OUT, counterclockwise, backing pressure off the spring, preventing possible overpressuring of the system.

Opening Speed – Turn the adjustment screw on the Opening Speed Control OUT, counterclockwise, 1-1/2 to 2-1/2 turns from full closed position.

Step 2

Loosen a tube fitting or cover plug at the main valve to allow air to vent during start-up.

Step 3

Pressurize the line, opening the upstream isolation valve slowly. Air is vented through the loosened fitting. Tighten the fitting when a steady stream of liquid begins to vent.

SETTING THE PRESSURE REDUCING CONTROL

Step 4

Slowly open the downstream isolation valve to establish flow through the system.

Step 5

Fine tune the Pressure Reducing Control to the desired pressure set point by turning the adjustment screw IN, clockwise to increase or OUT, counterclockwise to decrease downstream pressure.

Step 6

Opening Speed Flow Control Adjustment: The opening speed flow control allows free flow into the cover and restricted flow out of the cover of the main valve.

If recovery of pressure is slow upon increased downstream demand, turn the adjustment screw OUT, counterclockwise, increasing the rate of opening.

If the recovery of downstream pressure is too quick, as indicated in a rapid increase in pressure, possibly higher than the desired set-point, turn the adjustment screw IN, clockwise, decreasing the rate of opening.

CONTROL VALVE FUNDAMENTALS

Main Valve

- Diaphragm : Seat Ratio
 -1 1/2 diaphragm area to 1 seat area

Flow Directions

- Under the seat
 -Waterworks and all general applications
 -If diaphragm wears/leaks, valve still flows

Golden Rules

- Fluid into cover – valve closes
- Fluid out of cover – valve opens
- What the control does, the valve does
 -Pilot on outlet
 *If it opens, valve opens
 *If it closes, valve closes

APPENDIX C (continued) MODELS 770-790

Piping Schemes

- 2-way (T to cover)
 - Supply Line
 - *Restriction in line
 - *Location of Speed Control
- Control/Discharge Line
 - 2-way pilot control in line
 - *On/Off
 - *Variable restriction
 - Valve position varies or modulates
- Supply to Discharge relationship
 - Supply restriction is required for valve to regulate

3-Way Piping

- Operation
 - #1 – Routes fluid into cover-valve closed
 - #2 – Blocks supply – routes fluid out of cover-valve opens
 - Control typically used with low capacity pilots or valves smaller than 4"
 - *Solenoids
 - *Altitude
 - *Float
 - *Accelerator control
 - Used to increase capacity of 3-port controls

GUIDE TO TROUBLE SHOOTING PRESSURE REDUCING VALVES

PROPER START-UP

1. Valves should be started in a manner that allows for controlled pressurizing of the valve and the system.
 - a. The valve should be pressurized and vented.
 - i. Bleed the air off of the main valve cover
 - ii. Bleed the air off of the valve controls
 1. Trapped air will give a false reading unless it is eliminated.
 - b. Bring pilots into service with a pressure setting lower than that required.
 - i. Adjust to higher pressures as the system and valve stabilizes.
 - c. Pilot Adjustments.
 - i. Make all adjustments slowly, allowing for the control, valve and system to read the change
 - ii. Clockwise adjustments always increase the pressure setting.
 1. Turning the reducing control IN will INCREASE outlet pressure.
 2. Turning the relief/sustaining control IN will INCREASE the inlet or relief set-point.
 - iii. Counterclockwise adjustments always LOWER/DECREASE the pressure setting
 1. Turning the reducing control OUT will LOWER outlet pressure.
 2. Turning the relief/sustaining control OUT will LOWER the inlet or relief set-point.

ABOUT THE MAIN VALVE

1. Almost every function of control valve used in water applications call for a main valve flow of "under the seat".
 - a. If a diaphragm fails, the valve continues to allow flow.
 - i. Failure will be indicated by loss of pressure control or loss of positive shut-off

- b. Control circuit isolation ball valves can be used to isolate valve cover to allow for diaphragm condition check without removing the cover.
 - i. Close inlet ball valve
 - ii. Close cover ball valve
 - iii. Close outlet ball valve
 - iv. Bleed cover fluid
- c. Valve will open – fluid will continue to flow if diaphragm is damaged.

2. VALVE WILL NOT OPEN-CHECK PILOT SYSTEM

- a. Check opening speed control – OPEN.
- b. Check on/off devices.
 - i. Solenoid
 - ii. Deadman control
 - iii. Hydraulic check function
- c. Check system
 - i. For flow demand
 - ii. Inlet pressure
 - iii. Closed isolation valves
- d. Check function of hydraulic controls.
 - i. See pilot trouble shooting guidelines
 1. Take corrective action.

3. VALVE WILL NOT CLOSE

- a. Check pilot system.
 - i. Check closing speed control – OPEN
 - ii. Check on/of device for complete closing
 1. Solenoid
 2. Hydraulic check function.
 - iii. Check function of hydraulic controls
 1. See pilot trouble shooting guidelines.
 - a. Take corrective action.

4. VALVE WILL NOT REGULATE

- a. This is normally a problem with the hydraulic controls.
 - i. Check response to adjustments
 1. Service pilots as required.
 - ii. Check and adjust speed controls
 1. Gauge swings to higher than acceptable pressures.
 - a. Adjust for slower opening speed.
 - b. Adjust for faster closing speed.
 2. Gauge swings to lower pressures than acceptable.
 - a. Adjust for faster opening speed.
 - b. Adjust for slower closing speed.

APPENDIX D MODELS 770-790

ADJUSTABLE OPERATING RANGE	MINIMUM DEAD BAND.	PROOF PRESSURE	FACTORY SETTING
IPS40-1	9000104	1	10-175 PSI

Listing/Approvals: UL Standard 508 Guide (NKPZ) and CSA Standard C22.2 No. 14-M Class (321106) for Pressure Operated Industrial Control Equipment.

UL Standard 873 Guide (XAPX) and CSA Standard C22.2 No. 24 Class (481302) for Temperature Indicating and Regulating Equipment.

CE Marked

Ambient/Media Temperature Range:

-4°F to 180°F (-20°C to 82°C)

Construction:

- NEMA Type 4X Enclosure for indoor or outdoor use. (To maintain 4X rating, use appropriate Type 4 conduit hub.)
- Forged Brass or 316 S.S. Pressure Connections.
- Aluminum Diecast Base with Polymer Enclosure.
- Beryllium Copper Diaphragm (Stainless steel isolator diaphragm included for protection of beryllium copper diaphragm on models with stainless steel pressure connection.)
- Nitrile Pressure Sealing O-ring.

Switch Contact:

Snap Action SPDT (Form C)
 15 Amps at 125/250/480 VAC
 1/8 HP at 125 VAC
 1/4 HP at 250 VAC

General Description

The pressure switch is an Adjustable Deadband Pressure Switch with independent set and re-set points which are adjustable throughout the entire operating range of the switch. The minimum deadband (minimum span between set and reset points) may be obtained at any point in the operating range of the switch. A change in pressure greater than the high setting will reposition the switch mechanism to open or close a single snap-action electrical switch.

This control device is designed for use as an operating control in applications sensing air, water, or any fluid not harmful to the pressure connection, diaphragm or nitrile pressure sealing o-ring. Where an operating control would result in personal injury and/or loss of property, it is the responsibility of the installer to add devices (safety, limit controls) that protect against, or systems (alarm, supervisory systems) that warn of control failure.

This device is not intended for applications in explosive environments or use with hazardous fluids.

ADJUSTMENTS

The two thumb adjustment dials, accessible through the enclosure cover, are used to adjust the set point and reset point of the switch. The dial scales and pointer may be used to give an indication of the low and high set points. The high setting adjustment dial is calibrated for increasing pressure. The low setting adjustment dial is calibrated for decreasing pressure. For best accuracy, make the final adjustments with a pressure gauge at the actual working media pressure and temperature encountered in the application.

The minimum deadband (minimum span between set and reset points) may be obtained at any point in the operating range of the switch.

When the desired settings are obtained, replace the adjustment cover. The adjustment cover and enclosure cover can be made tamper resistant by a single sealing wire inserted through the hole in the locking bar.

The repeatability of the set and reset points is typically $\pm 1\%$ of the operating range.

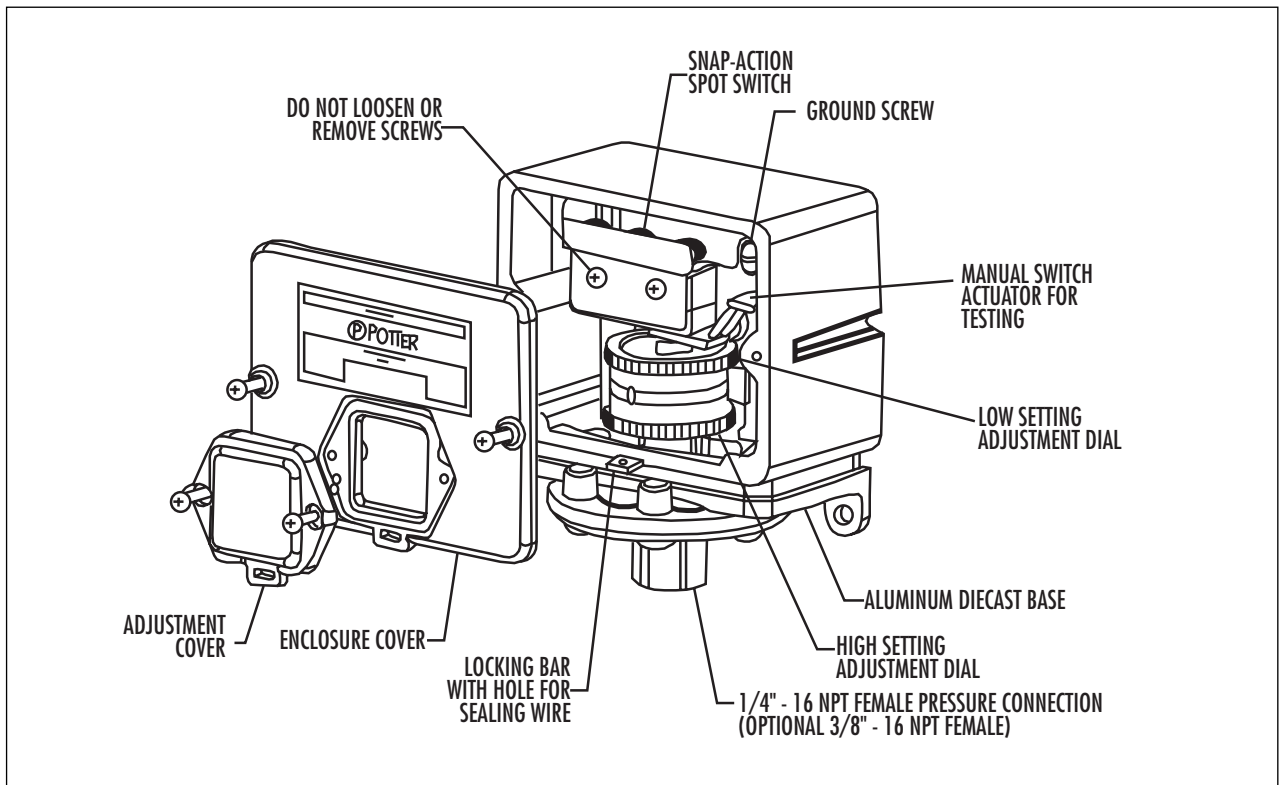

Series 790 Constant Pressure Booster Systems • with stackable pumps

- Capacities to 1200 G.P.M. (272.5 M³/HR)
- Pressures to 346 PSI (244 M)
- Potable Water Application



Constant Pressure Pumping Introduction

CP Boss, Aurora Pump's Packaged Constant Pressure Booster Systems are designed to meet the ever increasing demand of variable flows in high-rise, commercial, municipal and industrial buildings. These PLC based systems are available in vertical configurations. Easy to select and install, pre-engineered duplex and triplex units are available for quick delivery. Each system is performance tested for trouble free operation and ease of installation and start-up.

Feature Selector

STANDARD

- UL Labeled Pressure Sensing Control Panel
- PLC Pump Sequence Controller
- Duplex or Triplex
- Vertical Configurations
- Vertical Stackable Pumps
- High Efficiency Motors
- Steel Manifolds
- Complete Factory Test
- Pilot Operated Pressure Regulating Valves
- Maximum Pressure up to 175 PSI, Maximum Flows up to 1200 GPM
- Single Source Responsibility

OPTIONAL

- ASME rated Steel Bladder Tank
- Galvanized, Copper or Stainless Steel Headers
- Special Control Panels
- Current Sensing or Flow Sensing
- Simplex, Quadruplex Designs
- Specially Engineered Booster Systems for Higher Flows & Pressures



Packaged Constant Pressure Booster Systems described in this bulletin are used in offices and high rise buildings.

Pump Features

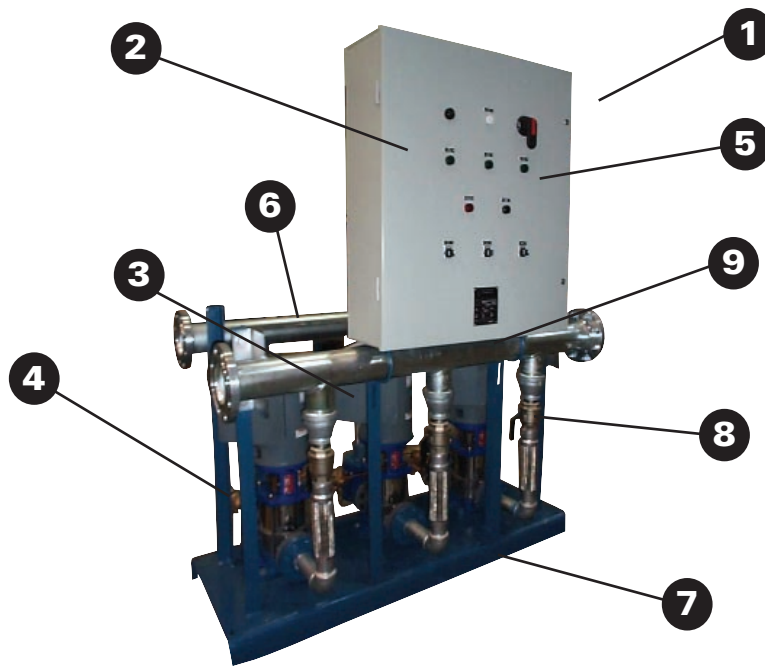

FEATURES

1. COMPLETELY ASSEMBLED and prewired for easy installation.
2. PRESSURE SENSING CONTROL PANEL: The Programmable Controller incorporated into the UL listed NEMA 1 Control Panel readily allows for the addition of optional control functions and alarm features.
3. SYSTEMS feature Aurora Pump 390 Series vertical multi-stage in-line pumps in stainless steel construction.
 - HIGH TEMP/HIGH PRESSURE MECHANICAL SEAL. Cartridge Design allows replacing seal with out removing the motor.
 - ALL WETTED COMPONENTS OF AISI 304 STAINLESS STEEL for corrosion resistance.
 - TUNGSTEN CARBIDE VS CERAMIC BUSHINGS for long life at high temperatures.
4. PRESSURE REDUCING valves automatically reduce higher inlet pressure to a constant downstream pressure regardless of changing flow rate or inlet pressure. Pilot control settings are readily accessible and are easy to adjust. Return flow is prevented through built in check valves. For some applications where constant discharge pressure is not critical or where suction pressure is relatively constant as with a reservoir, silent check valves may be substituted for pressure reducing valves.
5. PRESSURE GAUGES are located on panel.
6. STEEL MANIFOLDS are painted Aurora Blue for corrosion resistance and to meet various local codes. Flanged connections provide easy installation. All piping is Schedule 40.
7. WELDED GROUTABLE STEEL BASE provides complete support while still allowing the unit to be readily maneuvered for installation.
8. FULL-PORT BALL VALVES provided on each pump suction and discharge branch will allow individual pumps to be serviced without interrupted operation.
9. THERMAL RELIEF VALVE is installed in pump casing to prevent overheating and pump failure. The valve will automatically sense the rise in temperature and discharge some of the hot fluid causing the cooler fluid to enter the casing and the valve will then close.
10. HYDROPNEUMATIC PRESSURE TANK (not illustrated) can be optionally provided to maintain system pressure during periods of low demand. Depending on specific application, the tank can be located adjacent to the system in the equipment room, remotely located, or mounted with the system on the common baseplate.

Pump and System Selection Guide

All Packaged Booster Systems have a desired discharge pressure and a given suction pressure from the city water system, or from a suction tank. Individual pump boost pressure is usually the system boost plus the friction losses within the booster system pipe, fittings, and pressure reducing valves. Individual pump flow is usually two equal sized pumps on a duplex system, and a percentage such as 20% + 40% + 40% = 100% for a triplex system. Determine the system flow and boost as well as individual pump flow and boost.

- 1) Total System Flow in GPM _____
 Determine required flow per pump in GPM P1 _____
 (Total System Flow ÷ No. of Pumps) P2 _____
 P3 _____

- 2) Determine System Manifold Size
- | | |
|----------------|----|
| 0 – 140 GPM | 2" |
| 141 – 300 GPM | 3" |
| 301 – 600 GPM | 4" |
| 601 – 1000 GPM | 6" |

- 3) Determine Pump Head (TDH)
- A: Desired Pressure at System Discharge Manifold _____ PSIG
- B: Minimum Pump Suction Pressure _____ PSIG
 (City Supply or Tank)

Determine PRV Size(s)

PUMP FLOW	0-110 GPM	111-191 GPM	192-280 GPM	281-435 GPM
PRV SIZE	1-1/2"	2"	2-1/2"	3"

- C: Determine Flow Losses based on PRV Size _____ Ft. (See Chart Below)

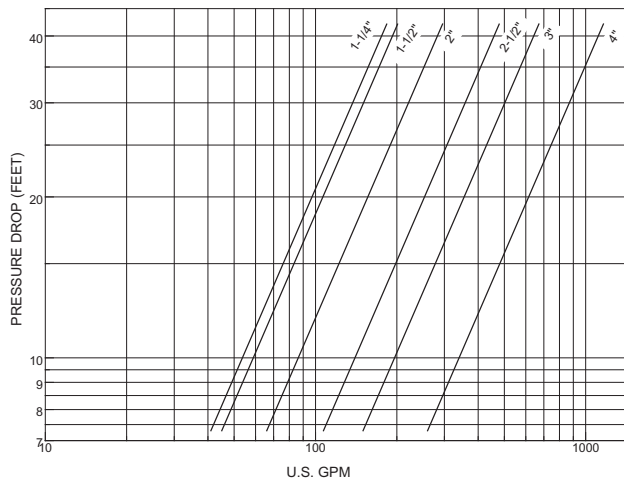

Calculate Required Pump TDH: [A - B] x 2.31 + C
 [(A) _____ PSIG - (B) PSIG] x 2.31 + (C) Ft. = _____ Ft.

Individual Pump Duty Points:

P1 _____ GPM @ _____ Ft. TDH
 P2 _____ GPM @ _____ Ft. TDH
 P3 _____ GPM @ _____ Ft. TDH

- 4) Select required pumps and motors using Aurora H2Optimize or the current Aurora Pump catalog

Range Charts

3450 RPM

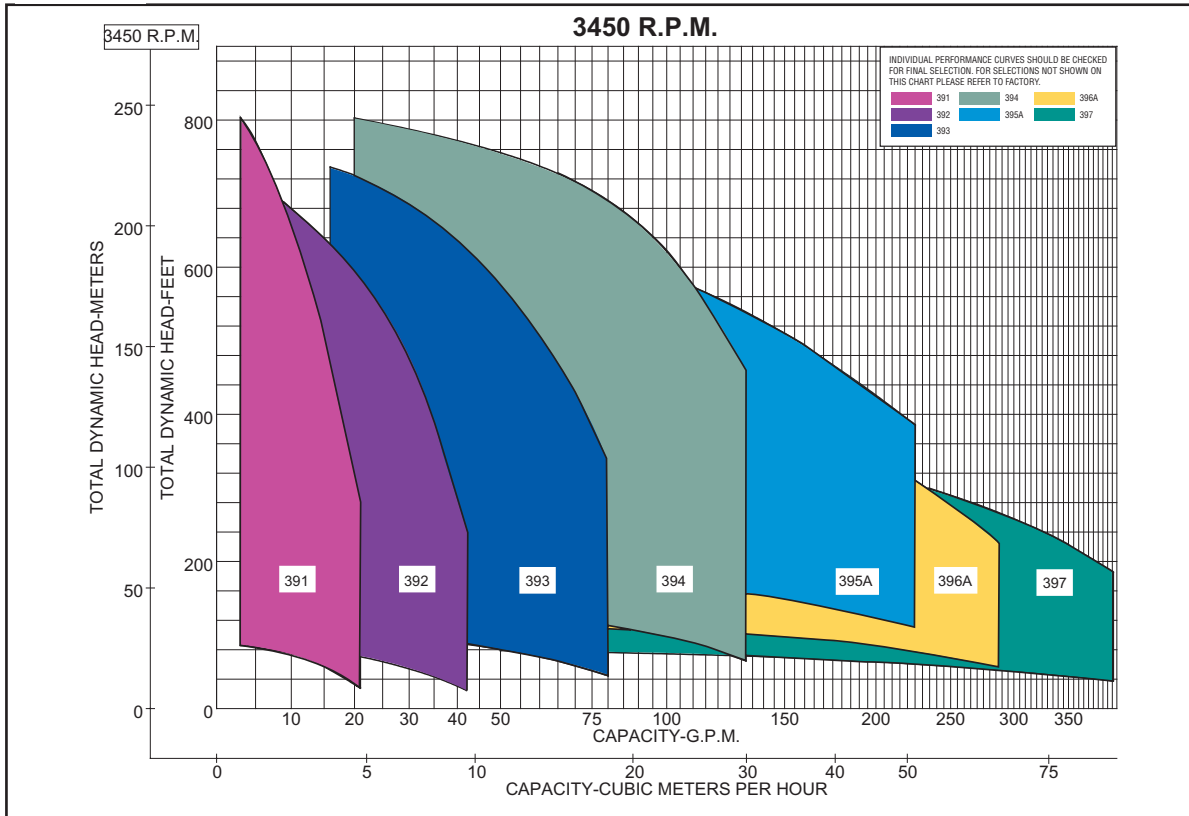

2880 RPM

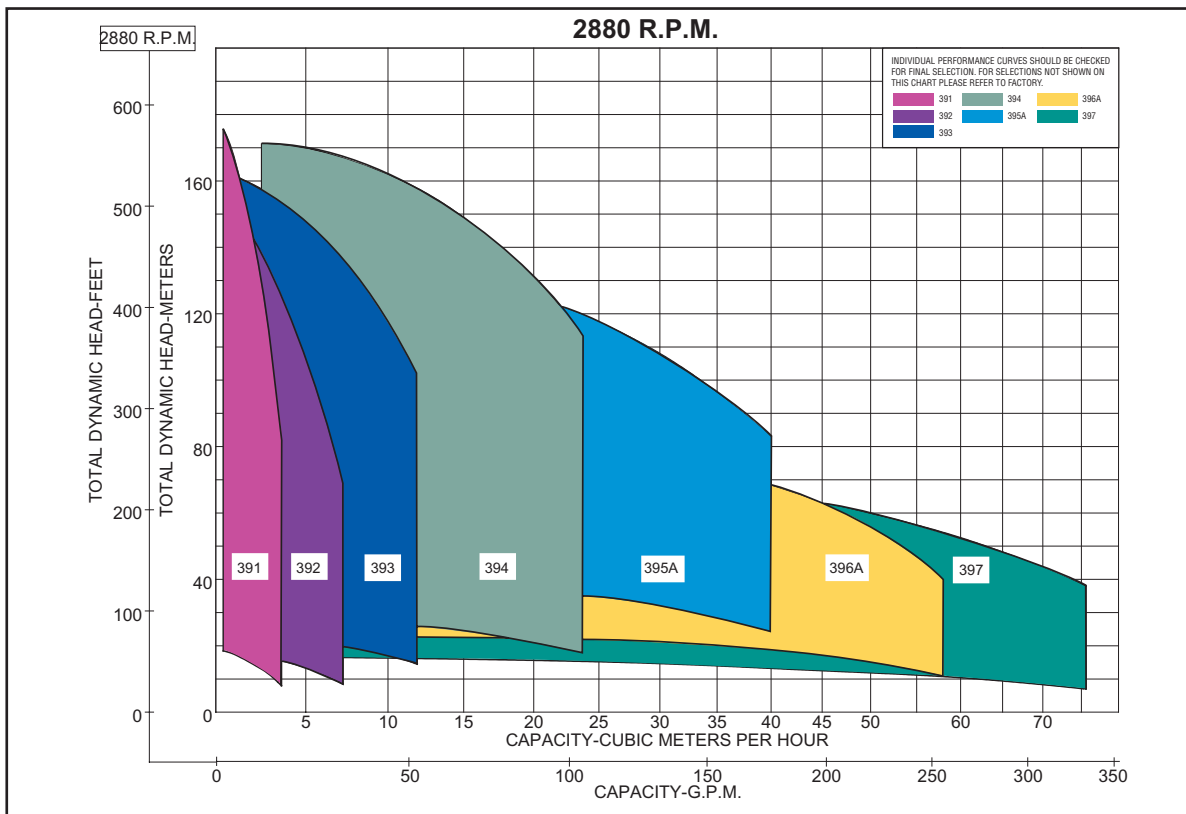

Pump Dimensions

DUPLEX

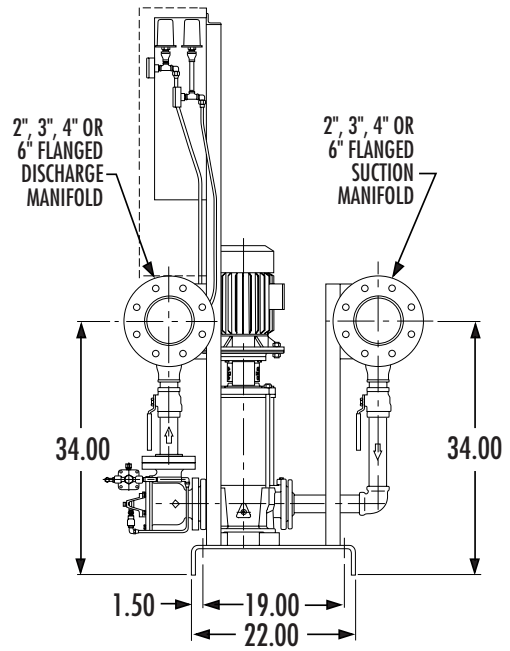
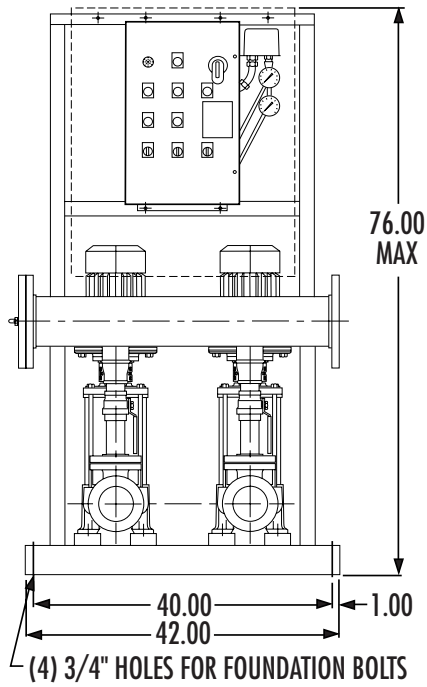

DUPLEX WITH TANK

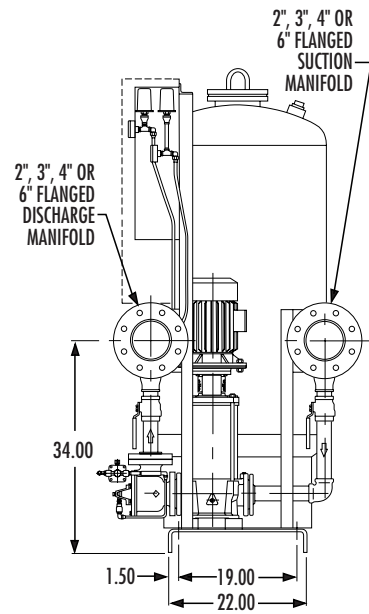
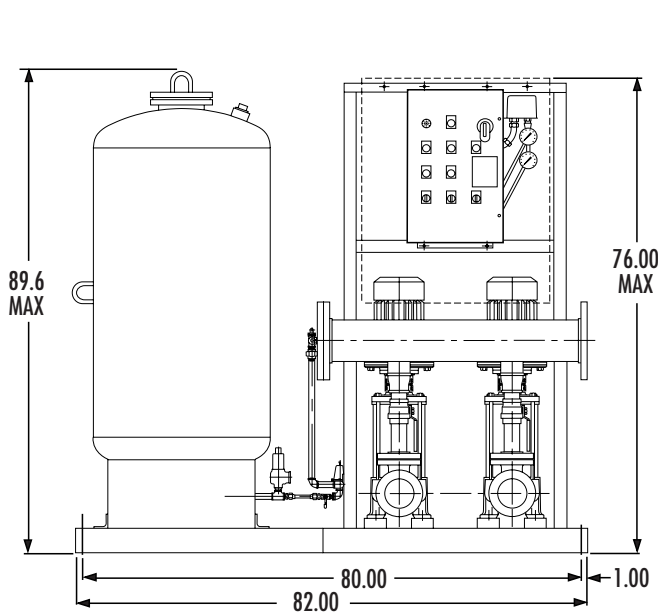

Pump Dimensions

TRIPLEX

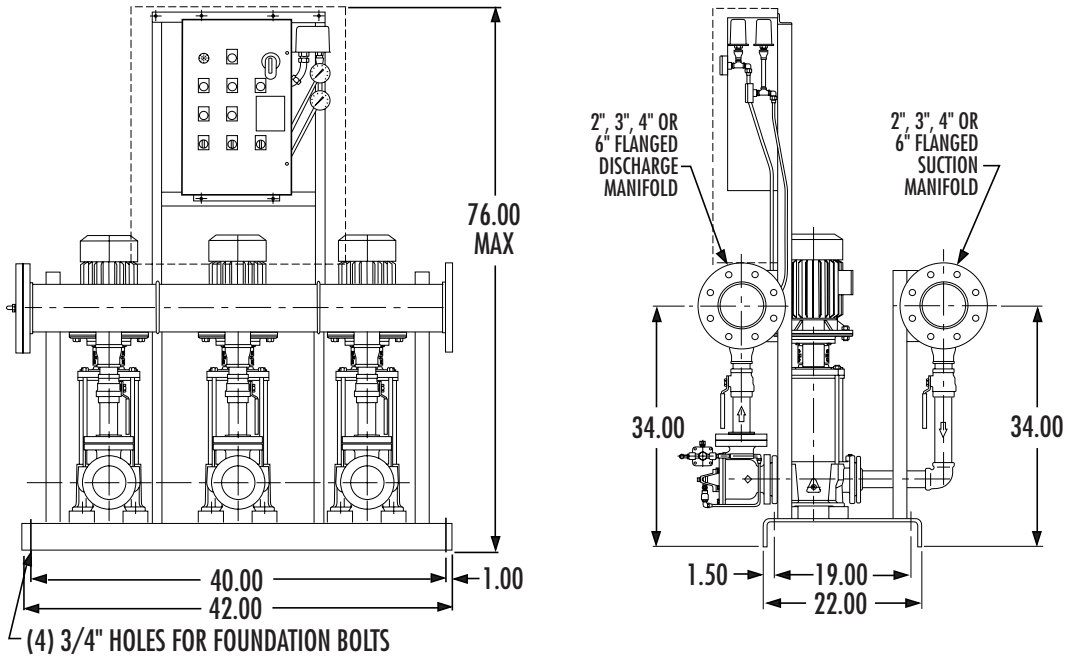

TRIPLEX WITH TANK

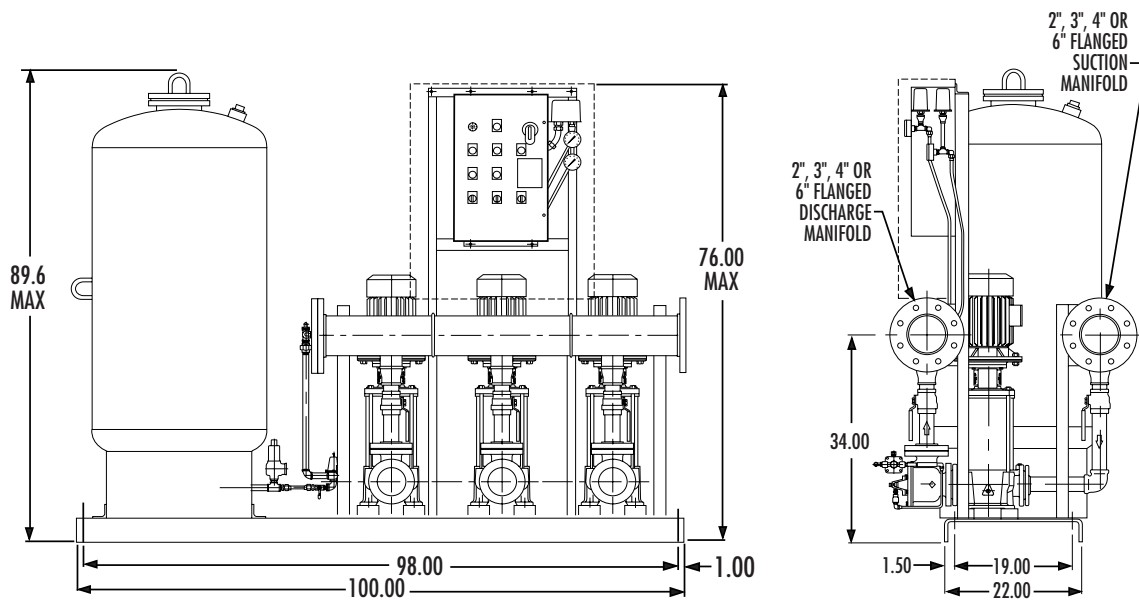

Engineering Specifications

The contractor shall furnish and install an Aurora Variable Flow (Duplex or Triplex) constant Pressure Booster System as manufactured by Aurora Pump. The unit shall have a total system capacity of.....GPM at a discharge head of.....feet when supplied with a working suction head of.....feet. Each pump shall be sized as indicated for a % of the total flow.

Duplex System

PumpP1 =GPM.....%System

PumpP2 =GPM.....%System

Triplex System

PumpP1 =GPM.....%System

PumpP2 =GPM.....%System

PumpP3 =GPM.....%System

PIPING AND VALVES

Each system shall be skid mounted, completely assembled and wired on a groutable steel base ready for installation. All piping shall be Schedule 40 Steel pipe. Each system shall include suction and discharge ball valves for each pump suction and discharge, combination pressure regulating/non-slam check valves for each pump, flanged connections for easy installation and pipe supports for the upper manifold. Suction and discharge pressure gauges shall be provided. Gauges shall have 3-1/2" faces with large scale numerals

and individual air bleed type valves.

PUMPS

The pumps shall be Aurora vertical multi-stage in line pumps. Each pump shall be constructed with 304 Stainless Steel impellers and diffusers, a high temperature mechanical seal with carbon vs Silicon Carbide, EPDM elastomer through out, Tunsten Carbide against Ceramic pump bushings and a Cast Iron motor bracket. Flanges will be Ductile or Cast Iron in Slip ring (and isolated from liquid).

MOTORS

The motors shall be NEMA C-FACE,HP, 3 phase, 60 Hertz,Volt, ODP, High-Efficiency. Motors shall be selected so that they do not exceed their nameplate HP rating through their entire range of operation.

CONTROL PANEL-PRESSURE SENSING

Each system shall have a mounted and wired UL Listed NEMA I Control Panel with individual magnetic motor starters, ambient compensated overload relays on each phase, individual motor fuseblocks with fuses, main circuit disconnect switch with door interlock, 110 volt control transformer with primary and secondary fuses. The panel shall be suitable for the horsepower and voltage of the motors. The Control Panel will incorporate a programmable logic

controller with pressure-sensing logic and have the following features:

- On and Off delays factory set to system operating characteristics to prevent short cycling of pumps.
- Individual pump run lights and selector switches
- Failure logic and indicating light to activate second pump if lead pump malfunctions.
- Automatic Lead/Lag pump alternation
- Low suction pressure shutdown with alarm light, horn and reset button.

TESTING

The entire system shall be tested at the factory to assure proper sequencing to meet the design flows and pressure; and the system components shall be adjusted at the factory.

SERVICES

The pump manufacturer shall assume unit responsibility and shall provide a factory trained engineer to supervise initial start-up to insure proper operation and to instruct the operating personnel in the operation and maintenance of the system.



NOTE: Aurora Pump reserves the right to make revisions to its products and their specifications, and to this bulletin and related information, without notice.

— Your Authorized Local Distributor —



MARKETING & SALES:

800 AIRPORT ROAD • NORTH AURORA, ILLINOIS U.S.A. • 60542
PHONE: (630) 859-7000 U.S.A./CANADA FAX: (630) 859-7060
WORLDWIDE FAX: (630) 859-1226

WEB: www.aurorapump.com

EMAIL: aurora_info@pentairpump.com

AURORA MFG. PLANT:

800 AIRPORT ROAD • NORTH AURORA, ILLINOIS U.S.A. • 60542

SALES OFFICES IN ALL MAJOR CITIES AND COUNTRIES

Refer to "Pumps" in yellow pages of your phone directory for your local Distributor.



SELECTION DATA

Dated **October 2003**

P1 [(A) _____ PSIG - (B) _____ PSIG] x 2.31 + (C1) _____ Ft. = _____ Ft.
 P2 [(A) _____ PSIG - (B) _____ PSIG] x 2.31 + (C2) _____ Ft. = _____ Ft.
 P3 [(A) _____ PSIG - (B) _____ PSIG] x 2.31 + (C3) _____ Ft. = _____ Ft.

Individual Pump Duty Points:

P1 _____ GPM @ _____ Ft. TDH

P2 _____ GPM @ _____ Ft. TDH

P3 _____ GPM @ _____ Ft. TDH

TANK SELECTION & MOUNTING OPTIONS:

Select the tank size required:

 120-132 gallon 158-165 gallon 211-220 gallon

Select tank pressure:

 125 175

Tank mounting:

 Remote (by others) Factory mounted on system base
PUMP & MOTOR SELECTION:

Select required pumps from the CP Boss Bulletin. Curves are available from the 390 section of the Aurora Pump catalog or H2Optimize.

CONTROL PANEL SELECTION:

Control Panel Configuration:

 Duplex Triplex

Controller Phase:

 1 3

Controller Voltage:

 115 208 230 460

Pump Horsepower Requirements:

Duplex: P1 _____ HP Triplex: P1 _____ HP

P2 _____ HP P2 _____ HP

P3 _____ HP

Pump Sequencing:

 Pressure Sensing Flow Sensing Current Sensing

Control Panel Options

- A High System Pressure Switch & Light
- B High Suction Pressure Switch & Light
- C Low System Pressure Switch & Light
- D Three Phase Lightning Arrestor
- E O/L Trip Light (alarm w/silence PB Std)
- F Failure to Start Light
- G Circuit Breakers in Place of Fuses
- H Individual Motor Disconnects
- J NEMA 4 Enclosure
- K NEMA 12 Enclosure
- L PLC Display Module

AURORA 790 CP BOSS

SELECTION DATA

Control Panel Options Cont.

- M PLC Computer Link Cable
- N PLC Memory Cartridge
- P Lead/Lag Manual Selector Switch
- Q Remove Alarm Contacts
- R Space Heater with Thermostat
- T Tank Pressure Switch
- W Elapsed Time Meter
- X Pressure Transducer
- Z PLC Real Time Clock

SYSTEM TESTS:

Standard Factory Test: All CP Boss systems are factory tested to assure proper sequencing to meet the design flows and pressure.

OPTIONAL FACTORY TESTS

- Certified Test
- Witness Test

SYSTEM DIMENSIONS:

Dimension Page _____ (from catalog)

AURORA MODEL 790

VERTICAL DUPLEX
WITHOUT TANK

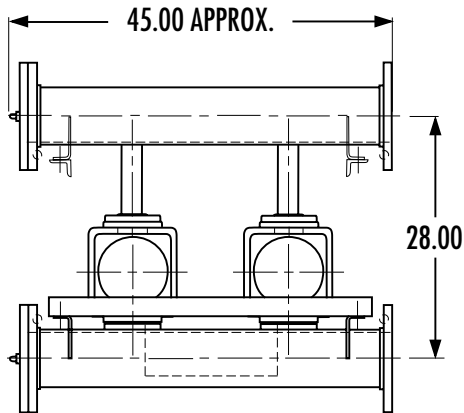

NOTES:

- 1. ALL DIMENSIONS ARE IN INCHES AND MAY VARY $\pm 1/2"$.
- 2. NOT FOR CONSTRUCTION PURPOSED UNLESS CERTIFIED.
- 3. MANIFOLD FLANGES ARE ANSI STANDARD CLASS 250 FLAT FACE.
- 4. STANDARD (RIGHT HAND) ASSEMBLY IS SHOWN. CONSULT FACTORY FOR OTHER CONFIGURATIONS.

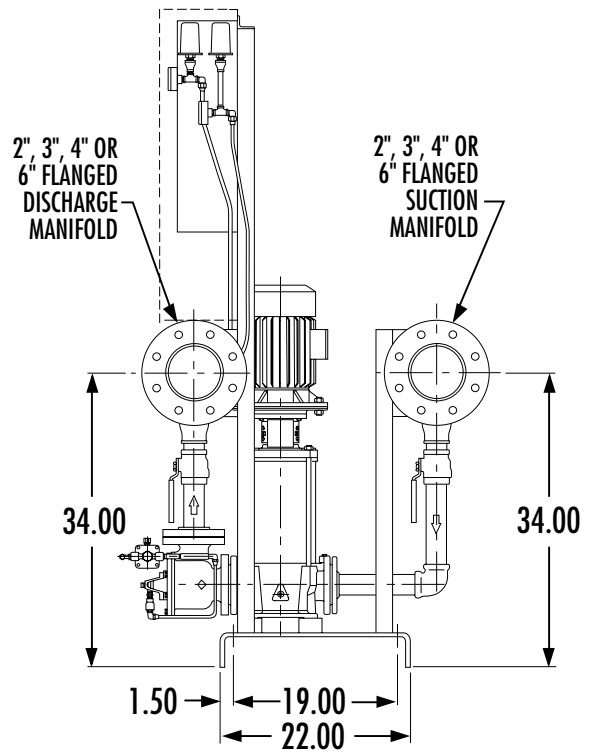
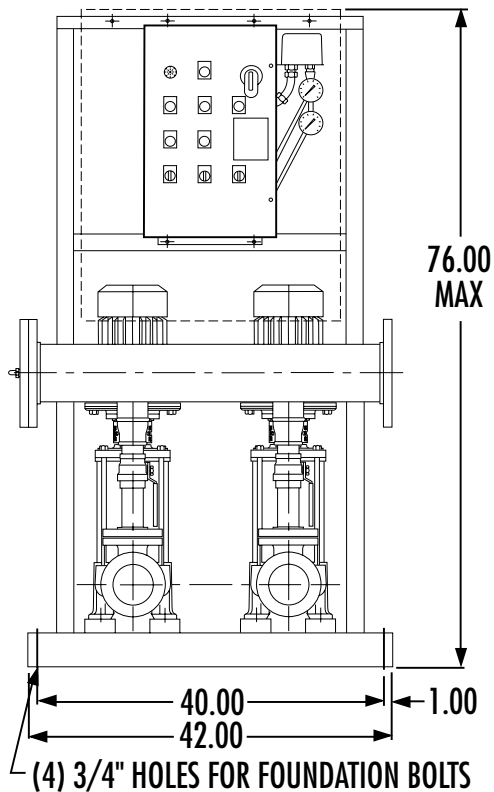

AURORA MODEL 790

VERTICAL DUPLEX WITH TANK

NOTES:

1. ALL DIMENSIONS ARE IN INCHES AND MAY VARY $\pm 1/2"$.
2. NOT FOR CONSTRUCTION PURPOSED UNLESS CERTIFIED.
3. MANIFOLD FLANGES ARE ANSI STANDARD CLASS 250 FLAT FACE.
4. STANDARD (RIGHT HAND) ASSEMBLY IS SHOWN. CONSULT FACTORY FOR OTHER CONFIGURATIONS.

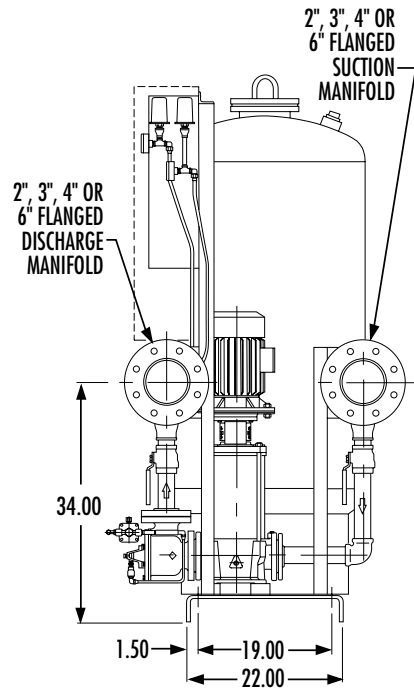
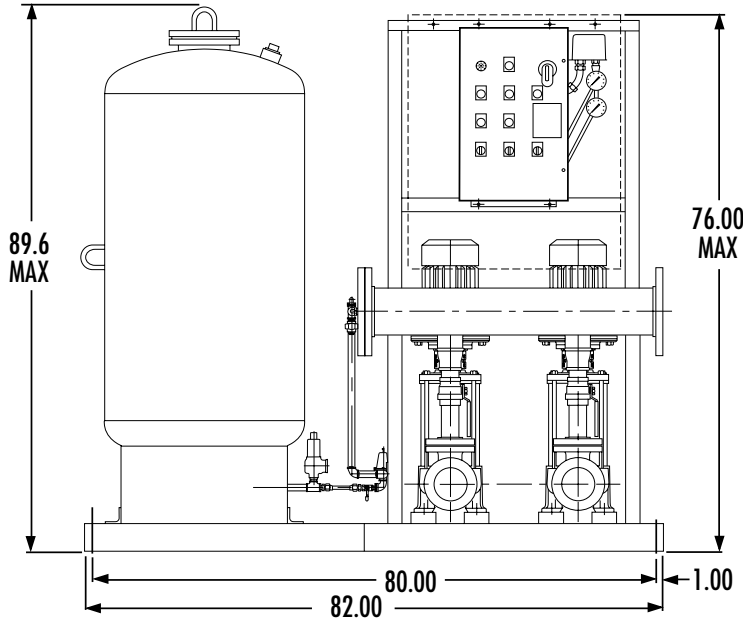
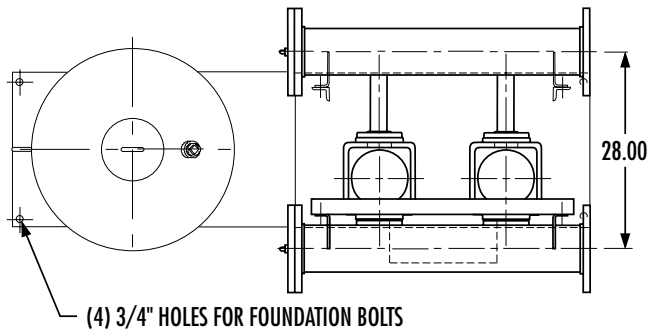

AURORA MODEL 790

VERTICAL DUPLEX
WITHOUT TANK

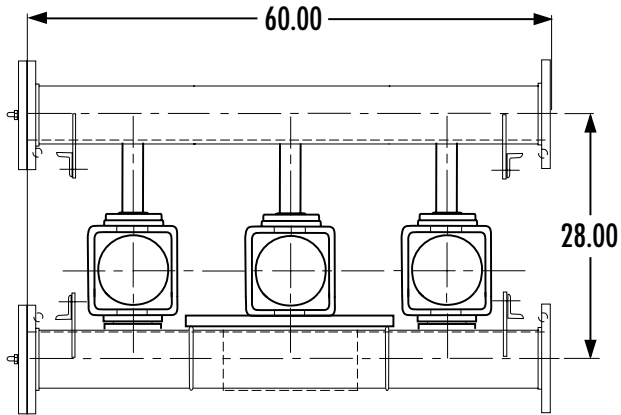

NOTES:

1. ALL DIMENSIONS ARE IN INCHES AND MAY VARY $\pm 1/2"$.
2. NOT FOR CONSTRUCTION PURPOSED UNLESS CERTIFIED.
3. MANIFOLD FLANGES ARE ANSI STANDARD CLASS 250 FLAT FACE.
4. STANDARD (RIGHT HAND) ASSEMBLY IS SHOWN. CONSULT FACTORY FOR OTHER CONFIGURATIONS.

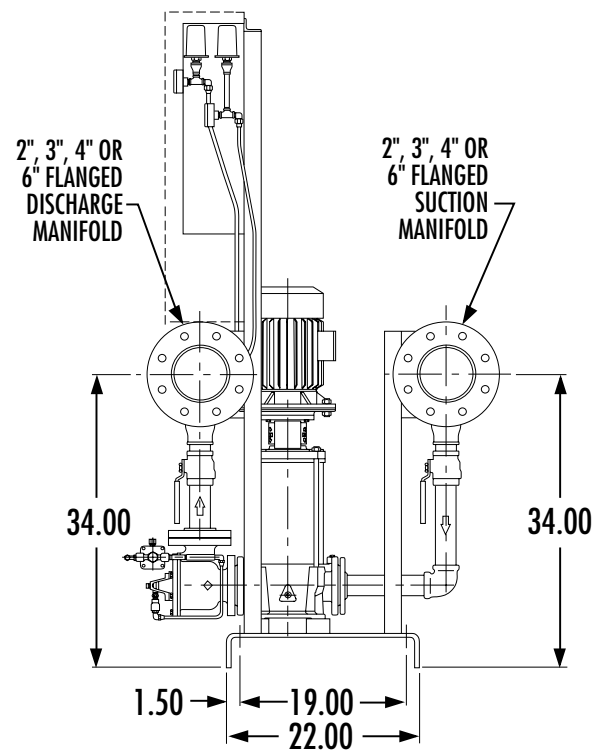
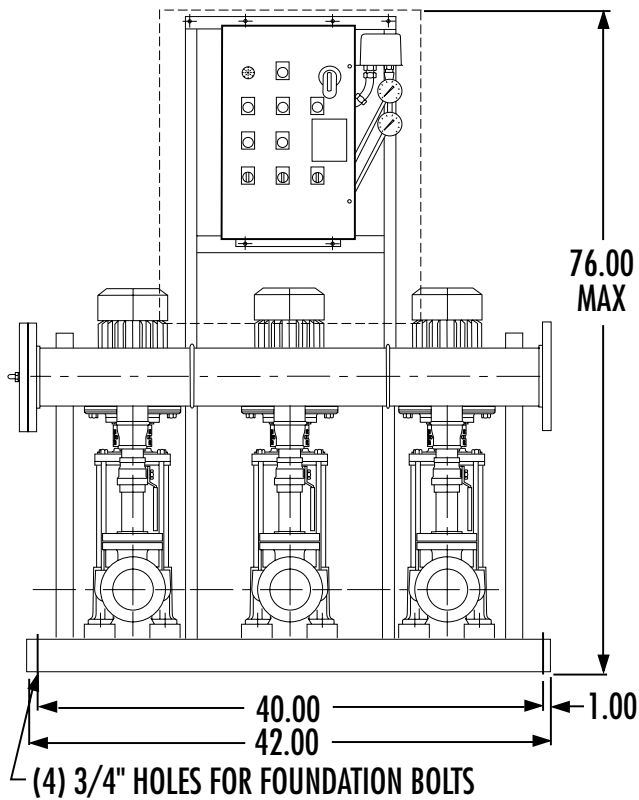

AURORA MODEL 790

VERTICAL TRIPLEX WITH TANK

NOTES:

1. ALL DIMENSIONS ARE IN INCHES AND MAY VARY $\pm 1/2"$.
2. NOT FOR CONSTRUCTION PURPOSED UNLESS CERTIFIED.
3. MANIFOLD FLANGES ARE ANSI STANDARD CLASS 250 FLAT FACE.
4. STANDARD (RIGHT HAND) ASSEMBLY IS SHOWN. CONSULT FACTORY FOR OTHER CONFIGURATIONS.

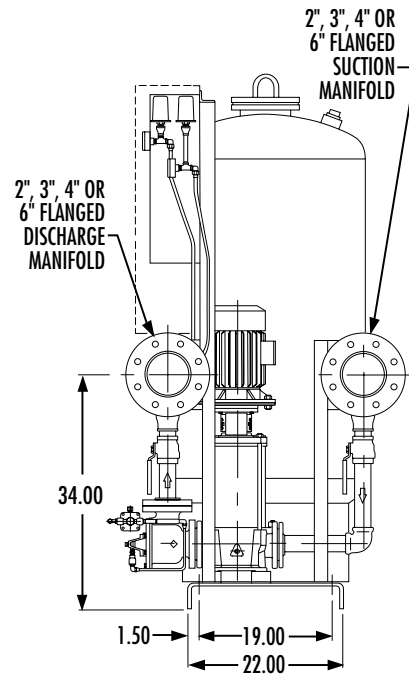
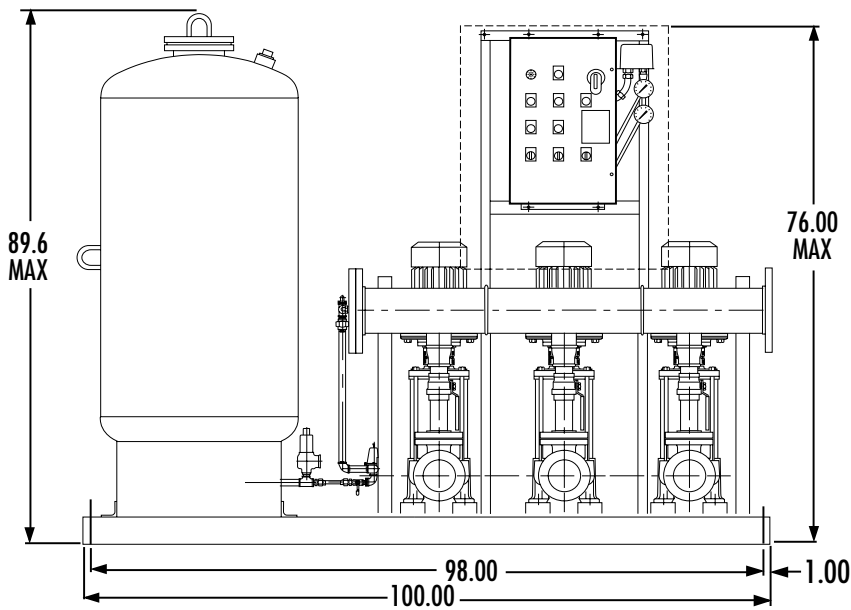
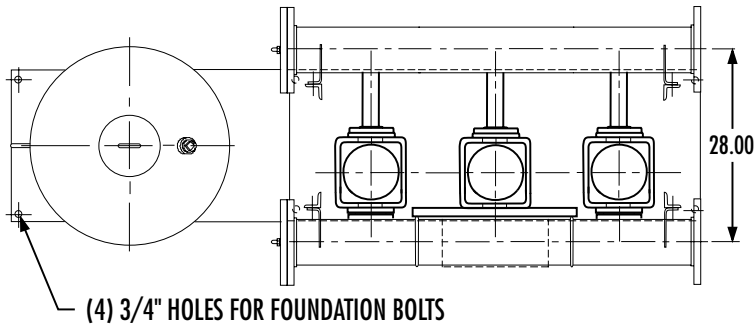

INSTRUCTION AND INSTALLATION MANUAL

MODELS 770, 790

BOOSTER SYSTEMS

2

ATTENTION: SAFETY WARNINGS:

Read and understand all warnings before installation or servicing pump.

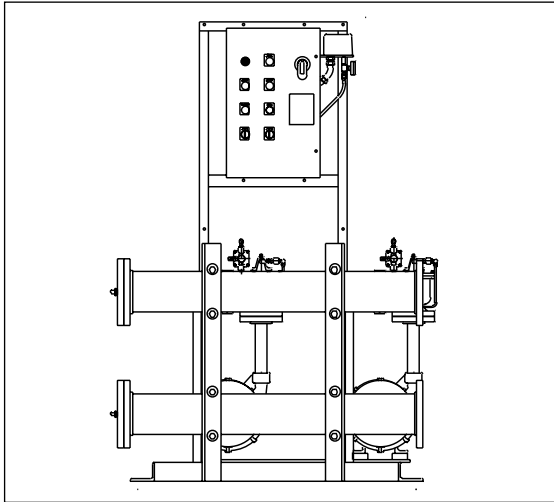

Standard 770 Duplex System with Horizontal Pumps

SYSTEM RECEIPT INSPECTION:

- Inspect system and components for signs of damage during shipment.
- Check system for missing parts.
- Check system for loose parts.

SYSTEM INSTALLATION:

- Mount and anchor system in properly prepared location.
 - Verify system is level and piping aligned with building system piping.
- Connect building piping to booster system, ensure no pipe stress is transferred to booster system.
- Ensure system disconnect switch is in the off position.
- Ensure pump H-O-A switches are in OFF.
- Have qualified electrician route power to system control panel.
- Grout system base using a "non-shrinking" grout.
- Route pump thermal relief valve discharges to appropriate floor drain.
- If system includes the optional, remote hydropneumatic tank, install tank in a suitable location and connect to booster system manifold.

CAUTION

Hydropneumatic tank is shipped from the factory with the isolation valve closed. Tank MUST be pre-charged to system pressure with air prior to opening isolation valve and admitting water.

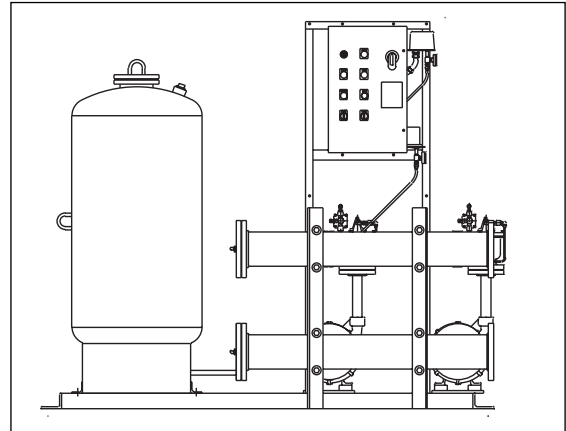

Standard 770 Duplex System with Horizontal Pumps

SYSTEM STARTUP:

- Open all system isolation valves.
- Slowly open booster system supply from building system.
- Open the petcocks on pumps and system manifolds to allow air to bleed from system.
- Turn booster control panel disconnect to ON.
- Jog pump motor #1 and observe direction of rotation. Take corrective action as required.
- Jog pump motor #2 and observe direction of rotation. Take corrective action as required.
- Turn pump #1 H-O-A switch to the hand position. Bleed air from the pressure reducing valve at the highest point on the valve by opening any fitting.
- Place pump #1 H-O-A switch to OFF.
- Turn Pump #2 H-O-A switch to the hand position. Bleed air from the pressure reducing valve at the highest point on the valve by opening any fitting.
- After all air is bled from the system, place system in operation by placing both pump H-O-A switches to AUTO.

OPERATION:

NOTE

Aurora booster systems are tested and adjusted at the factory prior to shipment. System pressure switches are factory adjusted to the specifications provided at time of order.

NOTE

Failure to properly vent system could result in erratic or sluggish operation due to air trapped in the system PRVs.

OPERATION (NO TANK):

When pump H-O-A switches are placed in AUTO, the lead pump will run continuously to maintain system pressure.

Check system suction pressure with pump #1 running. The low suction pressure switch is typically set at the factory at 5 psi OFF and 20 psi ON. The pressure switch setting can be changed as

MODELS 770-790

needed for the field condition. (See Controller Operation, Appendix A)

When flow demands increase beyond the pump design point the system pressure will begin to decrease.

The low system pressure switch is typically set at the factory at 10 psi below system pressure. The pressure switch setting can be changed as needed for the field conditions.

When system pressure reaches the pre-determined set point, the lag pump starts in response to the lower pressure. The lag pump will run as required until flow demand decreases and system pressure rises above the set point. When system pressure reaches the set point the lag pump will shutdown automatically and the lead pump will continue to run. During periods of low system demand/shutoff operation both pumps are provided with a thermal relief valve for protection. (See Controller Operation, Appendix A)

OPERATION (WITH OPTIONAL TANK):

When pump H-O-A switches are placed in AUTO, the tank pressure switch sequences the lead pump under no flow condition. The tank fills to its capacity and tank pressure starts to build up. This increase in tank pressure will stop the lead pump when the pre-determined set point is reached and after the minimum run time is satisfied. The tank will supply all "leak" loads. As tank pressure drops due to further system demands the lead pump will start after a time delay. The tank switch will continue to cycle the lead pump off and on as required to maintain tank/system pressure.

NOTE

Tank pressure switch high set point must be lower than the pump shutoff head.

Set the tank pressure switch high set point 5 psi above system pressure. Set the tank pressure switch low set point to normal system pressure.

Check system suction pressure with pump #1 running. The low suction pressure switch is typically set at the factory at 5 psi OFF and 20 psi ON. The pressure switch setting can be changed as needed for the field condition. (See Controller Operation, Appendix A)

With the lead pump running if the system pressure continues to fall due to flow demands the lag pump will start and run with the lead pump until the system demand is satisfied and the minimum run time setting is met. Pumps stop in the reverse order.

The low system pressure switch is typically set at the factory at 10 psi below system pressure. The pressure switch setting can be changed as needed for the field conditions.

In the event of tank pressure switch failure both pumps are provided with a thermal relief valve for protection.

APPENDIX A

APPLICATION:

Standard (Typical) Systems: These controllers are used to control one or more pump motors. On multiple pump installations, the pumps may be equal in size (horsepower) or may be different sizes. The most common systems are duplex systems with one small and one larger pump and triplex systems with one small and two larger motors, where the larger motors are typically of the same size. In standard units where one pump is smaller than the other(s) it is meant to run continuously. If it is in a duplex system, the pumps won't be alternated from Lead to Lag.

Alternation schemes:

Equal Size Pumps:

Yes for Duplex (both), and Triplex (all three).

Unequal Size Pumps:

No for Duplex, Yes for Triplex (Pumps #2 and #3). Pump #1 (the smaller pump) runs continuously.

Pressure Regulated Systems: Standard systems utilize a pressure regulating valve (PRV) for each pump. The pump motor controller responds to the system pressure to start and stop (control) the pump or pumps. When the system pressure drops below a preset amount, usually just below the PRV setting(s), the controller causes the next pump to start. When the pressure rises sufficiently, the controller stops the last pump started, usu-

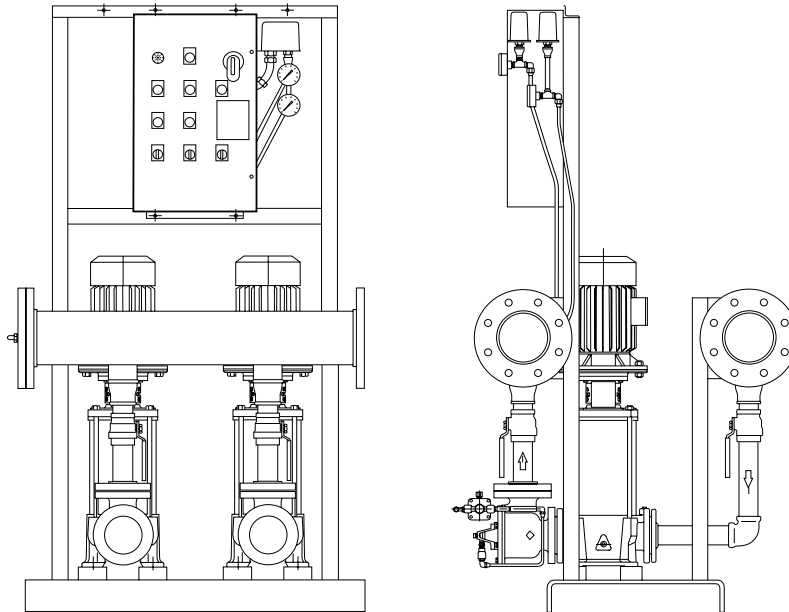

Standard 790 Packaged System

APPENDIX A (continued) MODELS 770-790

ally after a minimum running interval. A low pressure alarm and shutdown is included in standard systems to protect the pump(s) from running dry or cavitating on absent or low inlet pressure.

OPTIONAL SYSTEMS

Pressure Transducer Systems: The controller uses a solid state pressure transducer to control the operation (starting and stopping) of the motor(s). This takes the place of the System Pressure Switch. The transducer signal is connected to the PLC which has programmable start and stop set points. When the system pressure drops below the preset pressure, usually just below the PRV setting(s), the controller causes the next pump to start. Rising pressure causes the controller to cycle the pump(s) off.

Pressure Tank Systems: The booster pump system (package) may include an optional pressure tank to improve system performance. In this case the controller responds to pressure in the tank to maintain the tank pressure at a level above the system pressure in order to provide adequate pressure to the pressure regulating valve or valves. When the pressure rises sufficiently, the controller stops the last pump started, normally after a minimum running interval.

SEQUENCE OF OPERATION

General: These units control one or more booster pump motors to maintain the pressure in a system within a selected range. This is accomplished with a pressure switch which has a fixed differential (4 lbs @ 100psi). Refer to the wiring or schematic diagram for details. Standard units have one or more motor starters, a Control Power Transformer (CPT) and secondary and dual primary fuses for same. Standard units include a PLC for logic sequencing, timing and control. Standard units also include an audible alarm, which can be silenced, and one or more visual alarm lights. The standard unit also includes one or more Pump Running signal lights, L2 & etc.

Power Wiring: The input lines (mains) connect to the top of the Disconnect Switch (DS) or Circuit Breaker CB. Power flows through the short circuit protection motor Line (Mains) Fuses 1F & etc., or Circuit Breaker CB, and then to the Motor Starter, which is horsepower rated. The Motor Starter consists of Motor Contactor (1M & etc.) and Overload Relay OL-1 & etc.. When the Motor Contactor Coil 1M, or etc., is energized, Motor Contactor 1M contacts close to feed power through the Overload Relay to its output terminals where the motor is connected. This energizes the motor to start the pump.

Control Transformer: Control power is supplied by a Control Power Transformer (CPT). Its primary is supplied by two primary side line fuses. The secondary output of the transformer is protected by a secondary fuse. See the controller Schematic Diagram for the fuse designations. Secondary control power is 115 Vac (110 - 120 Vac) at 50 or 60 Hz depending on the line (mains) frequency. Secondary power is used for the motor contactor coils, indicator (pilot) lights, audible alarm, the PLC and any additional control relays or components.

Overload Relay: The Overload Relay furnished in the motor starter provide protection from excessive currents. The overload relay has been sized and set to trip open when the motor exceeds 125% of the Full Load Current (FLA) multiplied by the rated Service Factor (SF). Trip times vary depending on the magnitude of the current overload, the number of previous starts, the ambient temperature of the controller, and the size of

the overload element. Briefly, the Overload Relay is sized to allow initial starting currents while protecting the motor from excessive long starting currents or excessive running currents. (See Installation Instructions - Protection for proper sizing).

Power Available Light: A Power Available pilot light (L1) indicates then the disconnect switch (DS) or main circuit breaker is closed, and when power is supplied to the unit and when the CPT primary and secondary fuses are not blown.

Warning:

Use care when using the MANUAL (MAN) position of the control switch to avoid causing system Over Pressure.

Control Selector Switch: One selector switch, HOA-1 & etc., is included for each motor. The switch includes a "MAN" (Manual, Hand) position, an "OFF"(Safety) position, and an "AUTO" (Automatic Control) position. In the manual position, the Pressure Switch and all automatic control is bypassed so the contactor coil is continuously energized by the selector switch. The Overload Relay contacts also override the manual position to protect the motor.

"OFF" (Safety) Position: In the "OFF" position, the Motor Contactor coil is de-energized to prevent the motor from running.

Warning:

Use care when using the MANUAL (MAN) position of the control switch to avoid causing system Over Pressure.

"MAN" Position (Manual Control): Control power wiring is tapped off the incoming power on the load (down-stream) side of the Line Fuses or Circuit Breaker. It is routed to the three position (Auto-Off-Manual) selector switch. In the manual position, the all pressure switches and all automatic control is bypassed so the contactor coil is continuously energized by the selector switch. The Overload Relay contacts also override the manual position to protect the motor. The Minimum Run Timer does not operate with the selector switch in the MANUAL position.

"AUTO" (Automatic Control) Position: In this position, the motor starter is connected to the appropriate output terminal of the PLC (Programmable Logic Controller) which enables automatic control of the pump motor by the PLC. Note that overload relay operation is independent of the PLC or any other control circuitry to protect the motor.

Motor Running Light(s): The Pump 1 Running light activates when ever the motor contactor (starter) for Motor No. 1 is closed under either manual or automatic control.

AUTOMATIC (PLC) CONTROL

Alarm Circuit: The standard unit includes alarm circuitry to annunciate failure or fault conditions. The standard alarm condition is Low Suction Pressure as sensed by the Low Suction

APPENDIX A (continued) MODELS 770-790

Pressure switch (PS-1). When the pressure drops to less than the trip setting of this pressure switch, its contacts close. This signals the PLC that the condition has occurred. The PLC activates the Low Suction Audible Alarm. The standard audible device is a solid state (Sonalert) annunciator. The PLC also activates a Low Suction alarm signal light. The alarm can be silenced by momentarily operating the Alarm Silence switch (SW-1) which signals the PLC to de-activate the audible alarm. The alarm light stays lit until the Low Suction Pressure switch resets. The alarm circuit resets itself and re-activates on the next occurrence of low suction pressure.

General: In the AUTO position, motor operation is under the control of the PLC. The PLC utilizes an internally stored program to control the operation (starting and stopping) of the motor. The PLC responds to the Low Suction Pressure switch and to System Pressure Switch as a minimum. The PLC program also includes various timing functions as outlined below.

Pressure Sensing: The standard unit is pressure controlled by sensing either the system pressure or by sensing the pressure in a tank, if supplied. Multiple pump systems (Duplex & Triplex) may employ equal size pumps or one pump may be smaller than the others.

Alternation: The standard system employs one smaller pump and one or more larger pumps. If there is more than one larger pump (Triplex) they are usually equal in size to one another. The small pump is meant to run continuously. The controller cycles the larger pump or pumps as needed to maintain system pressure. Alternation of the pumps is not used in Duplex systems of this type. The smaller pump which runs continuously is considered the "Lead" pump and the other pump or pumps are considered the "Lag" pump or pumps.

When all pumps are of the same size, a duplex controller may be set up to alternate which of the two, or more) pumps operates as the Lead pump and which pump or pumps operates as the Lag pump or pumps.

Minimum Run Timing: The standard unit includes timers to control the Minimum Running time of the pump or pumps to prevent short cycling of the pump motor(s). This avoids overheating the motors which can occur if they are started too frequently. This allows the motor fan to cool down the motor windings from the last start before the pump is shut down.

Restart Delay Timing: The Restart delay prevents starting a pump which is still spinning down from the last running. This can occur when the demand is less than needed for the pump but more than what can be supplied by the other pump(s). In this case, when the pump shuts down, the pressure can drop rapidly enough to immediately signal the pump to start again. If the pump is still spinning, this can cause mechanical shock to the pump and motor and can also cause large spikes (momentarily large transient) currents which can blow fuses or trip circuit breakers. This occurs when the motor magnetic flux vector angle is out of phase with the power line phase angle by large enough difference. The Restart delay lets the motor come to rest or near rest which also allows the motor magnetic flux to decay. In this state, the motor can be safely restarted with out excessive transients and mechanical shock.

Alternation Times: Note: The Alternation Times apply only to controllers for two or more motors (Duplex & Triplex). The Alternation Time is the clock time that must elapse before the PLC changes the pump from being a Leading pump into a Lagging pump. The Alternation Times are independent of the

motor actual running time.

Alternator Overlap Time: When one or more pumps are not running, alternating the pumps can cause a momentary pressure drop when the running pump spins down before the other pump comes up to full speed. The overlap timer is an over run timer that causes a delay before the pump is shut down. This allows the second pump to come up to full speed while the first pump continues to run. After a typical setting of a few seconds, the controller shuts down the first pump if it is not needed for the system demand.

CONTROLLER SET-UP AND ADJUSTMENTS

Preliminary Steps: Before attempting to adjust the pressure switch in pressure controlled systems, adjust the pump pressure regulating valves for the desired system pressure(s). Remove the covers from the pressure switch(s). A system pressure gauge is required for setting the System Pressure Switch.



Warning: Shock Hazard

Some settings require observing or adjusting PLC settings and LED indicators. Use Caution to avoid contact with any electrical terminals, fuses, or connections to avoid electrical shock.

Timer (TIM) Settings: Note: Changing the timers requires one of three procedures. 1) The times are set at the factory using a lap-top computer with the appropriate program and communications cable, or 2) an optional memory chip can be programmed at the factory for the new times and added to the PLC in question, or 3) an HMI display and setting module can be installed onto the PLC for the purpose of changing the timer settings. Contact the factory for details on how this module is used. All timer settings are in seconds. The standard timers are factory set at the following settings:

$T0 + T9 = \text{Alternation Time on Pump \# 2} = 24\text{hr.}$
(Note: $T0(65535\text{sec}) + T9(20865\text{sec}) = 86400 \text{ seconds} = 24 \text{ Hours}$)
 $T1 + T10 = \text{Alternation Time on Pump \# 1} = 24\text{hr.}$
(Note: $T1(65535\text{sec}) + T10(20865\text{sec}) = 86400 \text{ seconds} = 24 \text{ Hours}$)
 $T3 = \text{System Pressure Start Delay} = 2 \text{ Seconds.}$
(Motor Restart Delay)
 $T4 = \text{Pump \# 1 Alternation Overlap Time} = 5 \text{ Seconds.}$
(Pump Over-run Timer)
 $T5 = \text{System Pressure Minimum Run Time} = 4 \text{ Minutes.}$
 $T6 = \text{Pump \# 2 Alternation Overlap Time} = 5 \text{ Seconds.}$
(Pump Over-run Timer)

Low Pressure (Cut-Off) Pressure Switch: Set the pressure switch to the desired cut-off pressure as indicated on the indicator dial. One example of a setting for a booster pump drawing suction from a municipal main would be 20 to 30 psi for the trip point of this switch.

Pressure Switch Set-up: To set the System Pressure switch (PS-2) remove its cover. Start the (lead) pump manually ("MAN" position) and modulate the system flow until the pressure drops just below the desired set point. Adjust the pressure switch On (Start) adjustment until the Input I-0 LED on the PLC lights. Set the pressure switch Off (Stop) setting as close as practical to the On setting. Typical settings on a 100 PSI nominal system would be trip (start) at 98 psi and reset at 102 psi. Verify the settings by modulating the system flow and observe when the PLC Input I-0 LED actuates and extinguishes.

APPENDIX A (continued) MODELS 770-790

REPLACEMENT PARTS LIST

<u>SYMBOL</u>	<u>PART NO.</u>	<u>DESCRIPTION</u>	<u>NOTES</u>
DS	302400	Disconnect Switch, 600 Vac, 30/40 Amp	(Internal Switch only)
DS	302401	Disconnect Switch, 600 Vac, 60/80 Amp	(Internal Switch only)
DS	302402	Disconnect Switch, 600 Vac, 100 Amp	(Internal Switch only)
---	400939	Disconnect Switch Handle Operator only,	(30 thru 100 Amp)
HOA	401199	Auto-Off-Manual Selector Switch	
---	401992	Contact Block (N.O.)	
PS*	305420	Standard Pressure Switch	
PS4	305421	Tank Pressure Switch	
PLC	305580	Programmable Logic Controller	(standard units only)
---	305040	Control Power Transformer, 50 VA, 208/240/460 Vac	
---	305041	Control Power Transformer, 50 VA, 208/380/575 Vac	

Note: One or more renewal parts such as fuses, heaters, contacts, and etc. may be obtained from local electrical distributor(s).

IMPORTANT: When ordering replacement parts, be sure to specify the complete MODEL NUMBER and SERIAL NUMBER of controller in which they are to be used.

SERVICE AND ASSISTANCE:

Contact either the Aurora Pump field agent or Factory customer Service for assistance. The factory can be contacted at the address and numbers show below.

Aurora Pump
800 Airport Road
North Aurora, IL 60542 USA

Phone: 630-859-7000 Fax: 630-859-7034
Web Page: <http://www.aurorapump.com>
Email: aurora_info@pentairpump.com

APPENDIX A (continued) MODELS 770-790

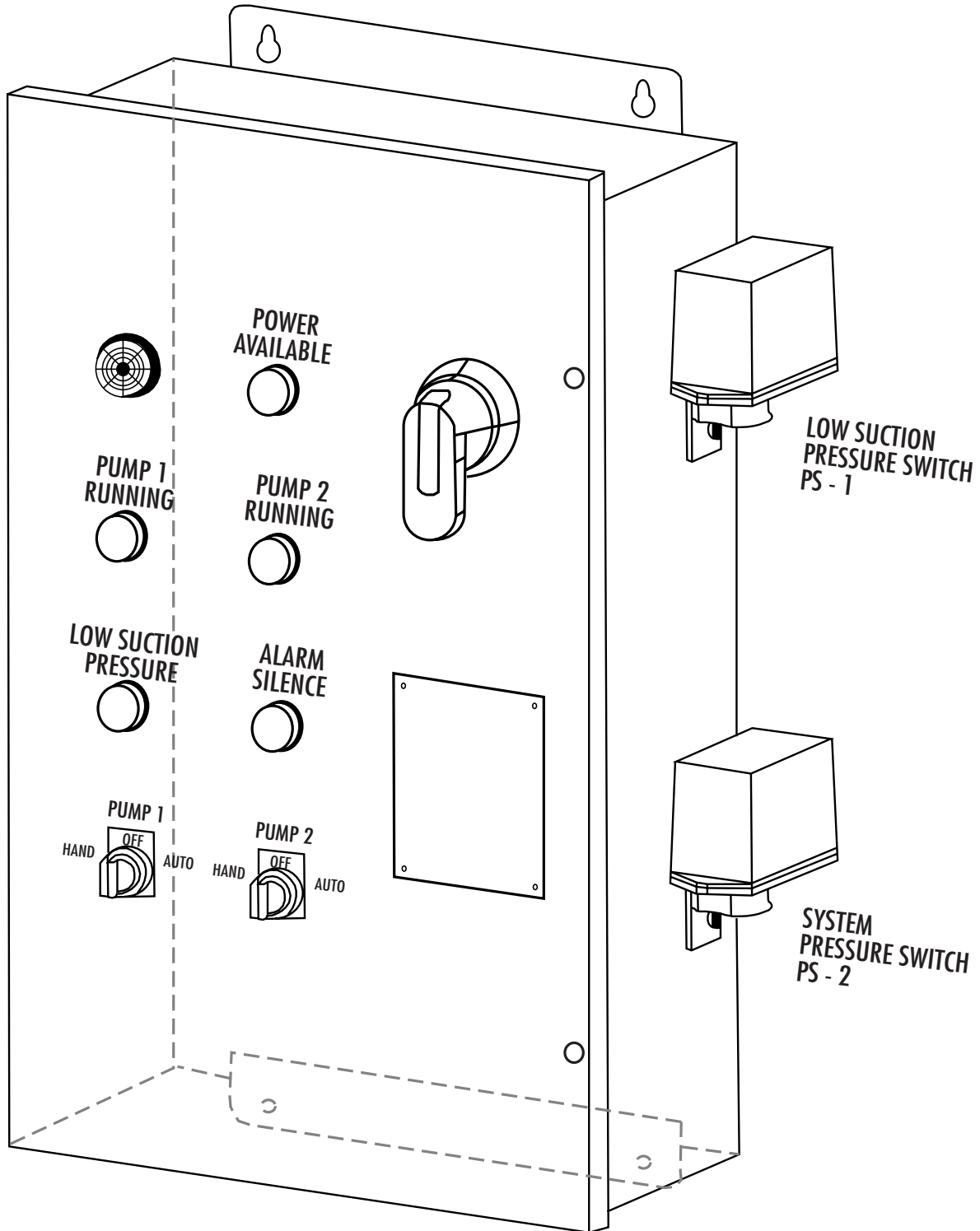

Notes:

- Enclosure: 16 Gauge Sheet Steel
- Finish: Grey Baked Enamel
- Application: For Indoor Use. NEMA 1
- Mounting: Wall Mount
- Max. Shipping Weight: 42 lbs. (20kg)

APPENDIX A (continued) MODELS 770-790

1
2
3
4
5
6
7
8
9
10
11
12
13
14
15
16
17
18
19
20
21
22
23
24
25
26
27
28
29
30
31
32
33
34
35
36
37
38
39
40
41
42
43
44
45
46
47
48

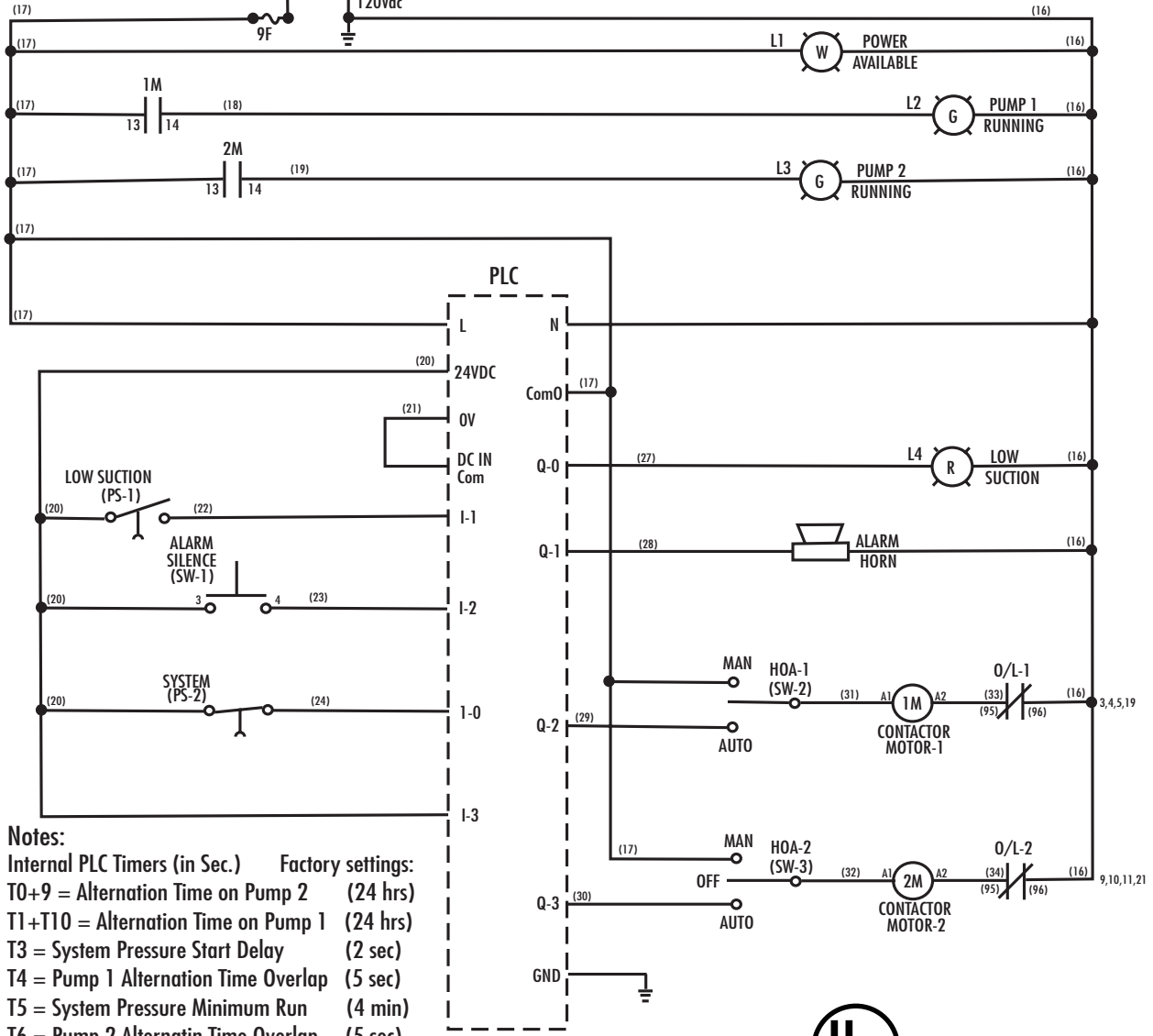
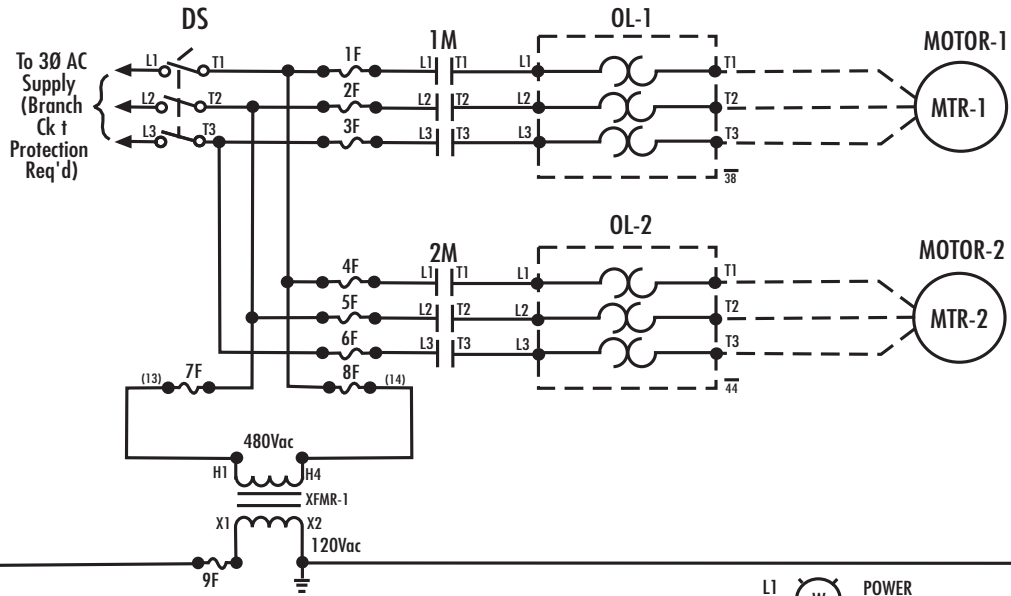

Notes:
 Internal PLC Timers (in Sec.) Factory settings:
 T0+9 = Alternation Time on Pump 2 (24 hrs)
 T1+T10 = Alternation Time on Pump 1 (24 hrs)
 T3 = System Pressure Start Delay (2 sec)
 T4 = Pump 1 Alternation Time Overlap (5 sec)
 T5 = System Pressure Minimum Run (4 min)
 T6 = Pump 2 Alternation Time Overlap (5 sec)



APPENDIX A (continued) MODELS 770-790

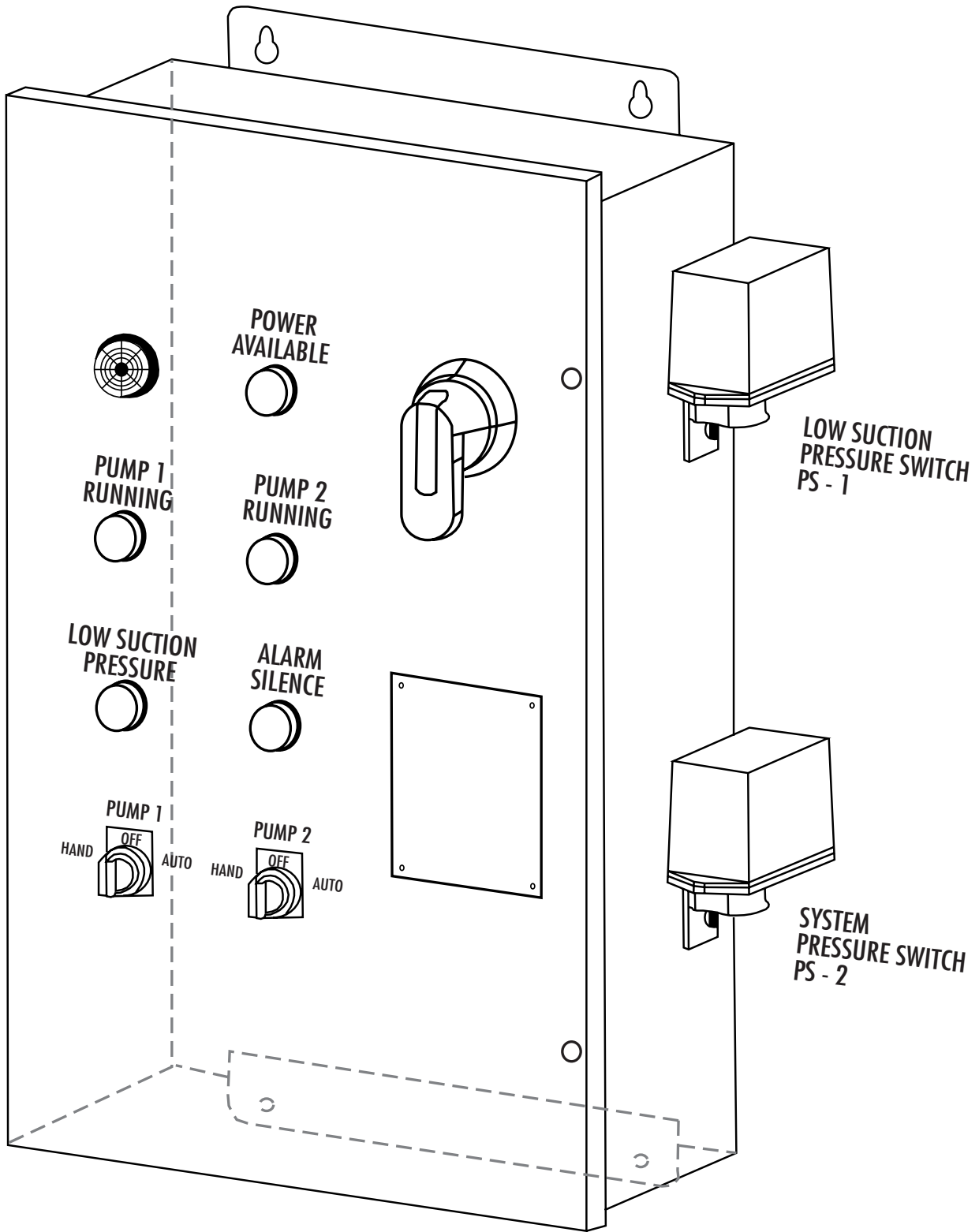

Notes:

- Enclosure: 16 Guage Sheet Steel
- Finish: Grey Baked Enamel
- Application: For Indoor Use. NEMA 1
- Mounting: Wall Mount
- Max. Shipping Weight: 42 lbs. (20kg)

APPENDIX A (continued) MODELS 770-790

1
2
3
4
5
6
7
8
9
10
11
12
13
14
15
16
17
18
19
20
21
22
23
24
25
26
27
28
29
30
31
32
33
34
35
36
37
38
39
40
41
42
43
44
45
46
47
48

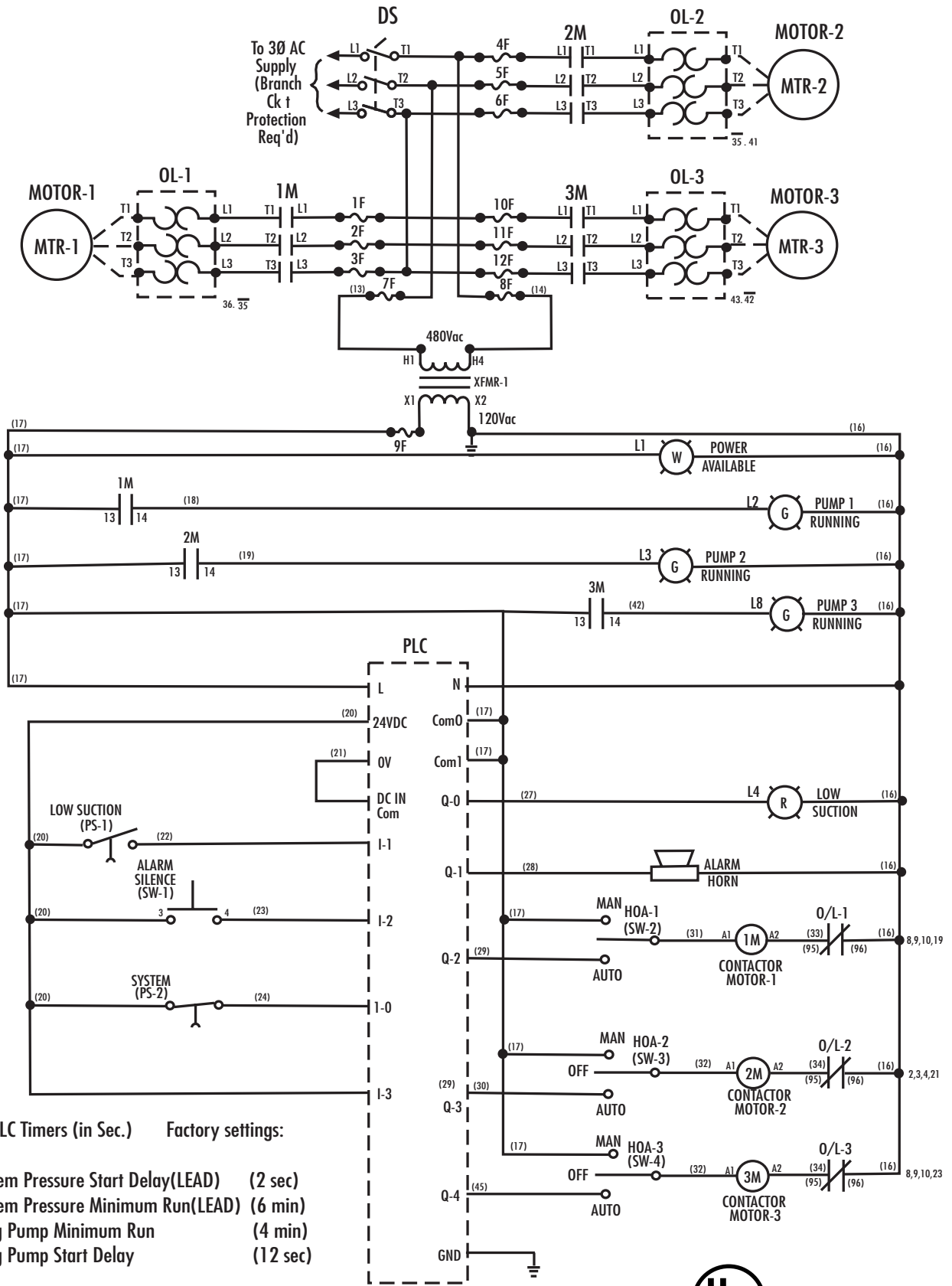

Notes:
Internal PLC Timers (in Sec.) Factory settings:
 T3 = System Pressure Start Delay(LEAD) (2 sec)
 T5 = System Pressure Minimum Run(LEAD) (6 min)
 T11 = Lag Pump Minimum Run (4 min)
 T12 = Lag Pump Start Delay (12 sec)



Option G

CIRCUIT BREAKERS IN PLACE OF LINE FUSES

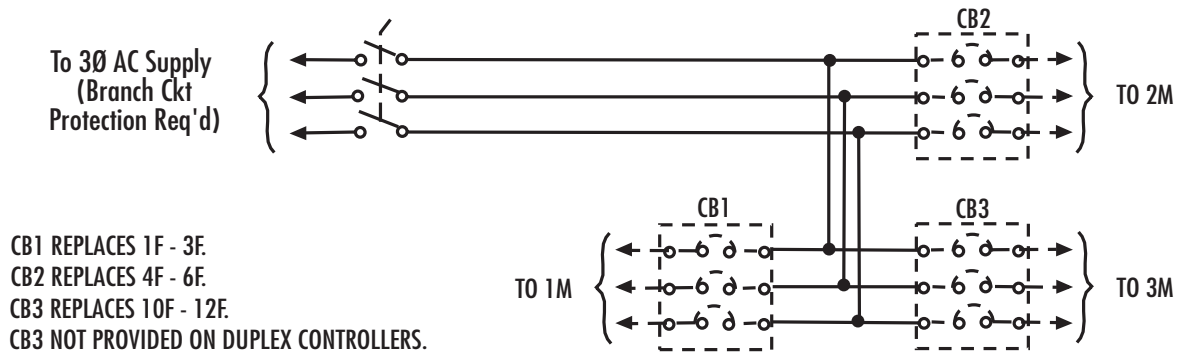

Option T

TANK PRESSURE SWITCH

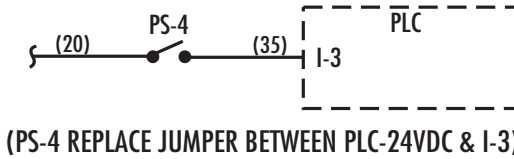

Option W

ELAPSED TIME METER

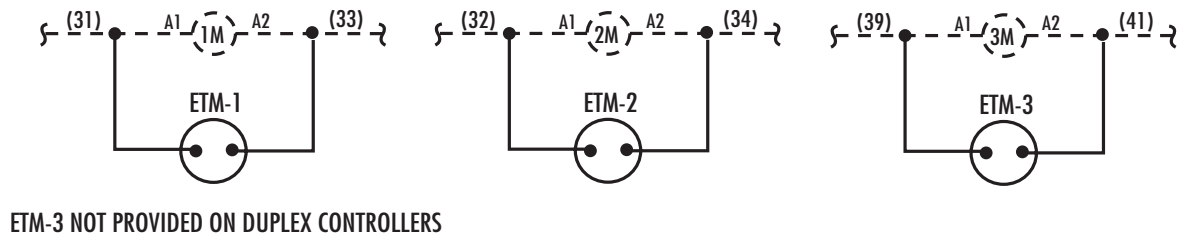

Option A

HIGH SYSTEM PRESSURE SWITCH, LIGHT AND ALARM

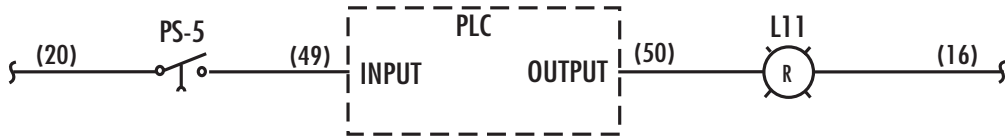

Option B

HIGH SUCTION PRESSURE SWITCH, LIGHT AND ALARM

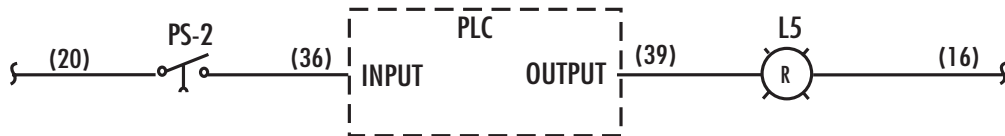

Option C

LOW SYSTEM PRESSURE SWITCH, LIGHT AND ALARM

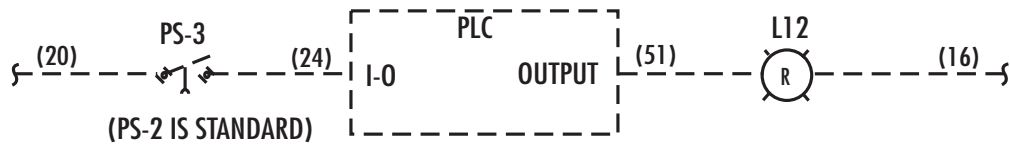

Option E

OVERLOAD TRIP, LIGHT AND ALARM

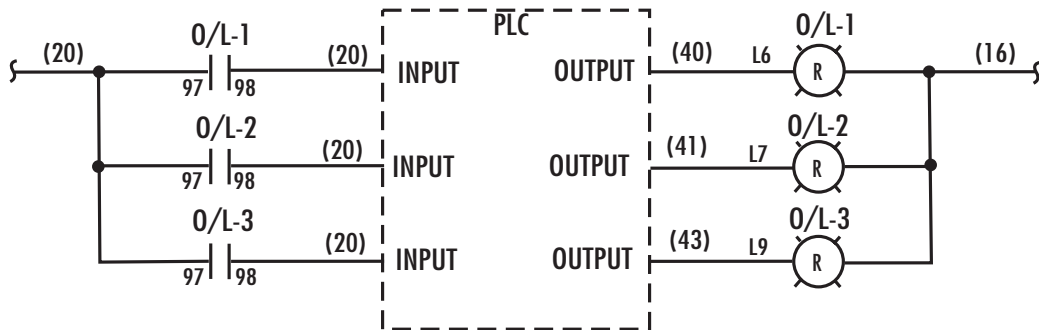

O/L-3 NOT PROVIDED ON DUPLEX CONTROLLERS

NOTE:
ALARM HORN AND SILENCE BB. SHOWN ON MAIN SCHEMATIC

APPENDIX B MODELS 770-790

MODEL	STOCK NO.	NO. OF CONTACTS	PRESSURE RANGE	PRESSURE CONNECTION
IPS40-1	9000104	1	10-175 PSI	NYLON 1/2" NPT MALE

UL LISTED and CSA Approved

Dimensions: 4-3/4"W x 2-1/4"D x 4-3/8"H

Enclosure: NEMA Type 4 for indoor or outdoor use. Cover – Die-cast with textured gray powdercoat finish. Base – Plated Steel with one opening for 1/2" conduit

Pressure Connection: 1/2" NPT Male

Differential Approx. (Not Adj.):

2 lbs. at 20 PSI; 5 lbs. at 175 PSI

Adjustable Range: 10-175 PSI

Maximum Pressure: 250 PSI

Switch Contacts:

One or two Snap Action SPDT (Form C Contacts)

15.0 Amps at 125/250 VAC

0.5 Amps at 125 VDC

0.25 Amps at 250 VDC

Pilot duty Rating: 125 VA 120/240 VAC

Ambient Temperature range:

-40°.180°F (-40°/82°C)

Media Temperature range:

32°/250°F (0°/121°C)

CAUTION

This device is not intended for applications in explosive environments.

The Model IPS pressure switches are designed to indicate an increase or decrease in normal system pressure. On the two switch models the two switches operate independently of each other and each switch may be adjusted to actuate at any point

within their adjustable range. They are designed for applications sensing air, water or any fluid or gas not harmful to nylon or silicone.

They are not designed to be used with any fluid or gas classified as hazardous.

NOTE

To prevent leakage, apply Teflon tape sealant to male threads only.

⚠ **Warning:**

Use of pipe joint cement may result in obstruction of aperture and loss of signal.

MOUNTING:

Device should be mounted in upright position. (Threaded connection down.)

FIELD ADJUSTMENTS:

The operating point of the switch or switches can be adjusted to any point within their adjustable range. (10-175 PSI). To adjust the device, turn the adjustment knob(s) clockwise to raise the actuation point and counterclockwise to lower the actuation point. On the two switch models the two switches operate independently of each other and each switch may be adjusted to actuate at any point within their adjustable range. The pressure scales on the devices are approximate. Final adjustment should be made with a pressure gauge.

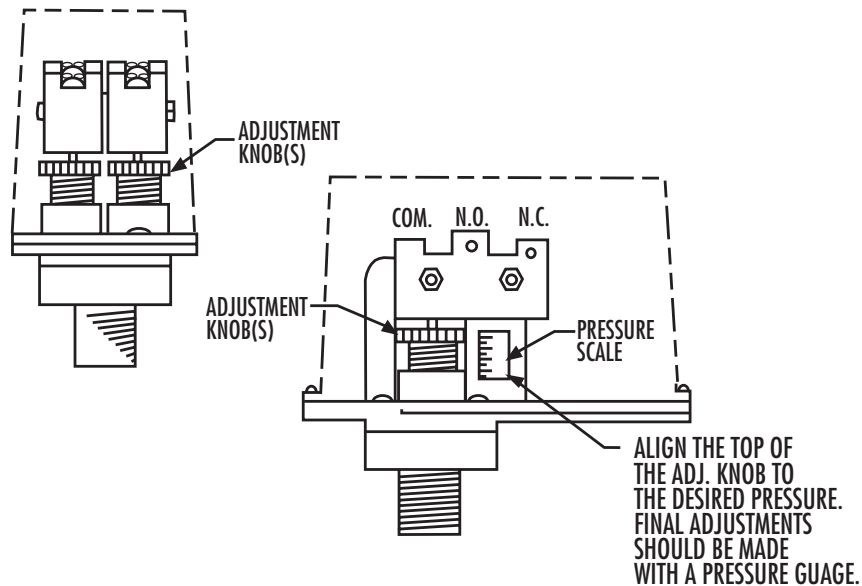

APPENDIX C MODELS 770-790

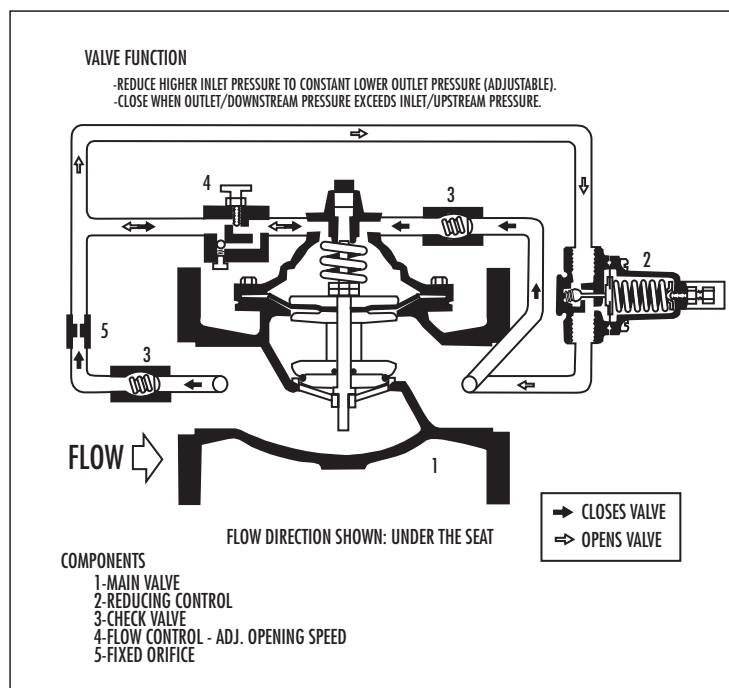

FUNCTIONAL DESCRIPTION

Pressure Reducing Function

The pressure reducing function is controlled by the 263AP or 263SS control. The 263 is normally open, adjustable control set to respond to outlet/downstream pressure changes. An increase in pressure above the set point of the control throttles the control towards closed. The main valve modulates towards a closed position. When pressure drops, the control throttles towards open, modulating the main valve towards an open position. A constant outlet/downstream pressure is maintained.

Turning the adjustment screw clockwise (IN) increases the outlet/downstream pressure, counterclockwise (OUT) decreases the outlet/downstream pressure.

Opening Speed Control – F.C.

An adjustable flow control adjacent the valve cover port, determines the opening speed of the main valve. It allows free flow into the cover and restricted flow out of the cover. Counterclockwise adjustment for faster opening, clockwise for slower opening. Complete closure prevents the main valve from opening.

Hydraulic Check Feature

When main valve outlet pressure exceeds inlet pressure, fluid is directed from the outlet to the main valve cover. This causes the main valve to close until inlet pressure / flow is again greater than outlet.

Main Valve – Description

CP-Boss automatic control valves are hydraulically operated, diaphragm actuated, pilot controlled, angle valves of packless design. The stem assembly is the only moving part in the main valve and is guided top and bottom. Positive, drip-tight, closure is accomplished by a quad seal and non-edged seat.

Start-Up and Adjustment

Close upstream and downstream isolation valves.

Open any ball valves or isolation cocks in the control tubing. Failure to open these will prevent the valve from functioning properly.

Step 1

Pre-set pilots as noted:

Pressure Reducing – Adjust OUT, counterclockwise, backing pressure off the spring, preventing possible overpressuring of the system.

Opening Speed – Turn the adjustment screw on the Opening Speed Control OUT, counterclockwise, 1-1/2 to 2-1/2 turns from full closed position.

Step 2

Loosen a tube fitting or cover plug at the main valve to allow air to vent during start-up.

Step 3

Pressurize the line, opening the upstream isolation valve slowly. Air is vented through the loosened fitting. Tighten the fitting when a steady stream of liquid begins to vent.

SETTING THE PRESSURE REDUCING CONTROL

Step 4

Slowly open the downstream isolation valve to establish flow through the system.

Step 5

Fine tune the Pressure Reducing Control to the desired pressure set point by turning the adjustment screw IN, clockwise to increase or OUT, counterclockwise to decrease downstream pressure.

Step 6

Opening Speed Flow Control Adjustment: The opening speed flow control allows free flow into the cover and restricted flow out of the cover of the main valve.

If recovery of pressure is slow upon increased downstream demand, turn the adjustment screw OUT, counterclockwise, increasing the rate of opening.

If the recovery of downstream pressure is too quick, as indicated in a rapid increase in pressure, possibly higher than the desired set-point, turn the adjustment screw IN, clockwise, decreasing the rate of opening.

CONTROL VALVE FUNDAMENTALS

Main Valve

- Diaphragm : Seat Ratio
 -1 1/2 diaphragm area to 1 seat area

Flow Directions

- Under the seat
 -Waterworks and all general applications
 -If diaphragm wears/leaks, valve still flows

Golden Rules

- Fluid into cover – valve closes
- Fluid out of cover – valve opens
- What the control does, the valve does
 -Pilot on outlet
 *If it opens, valve opens
 *If it closes, valve closes

APPENDIX C (continued) MODELS 770-790

Piping Schemes

- 2-way (T to cover)
 - Supply Line
 - *Restriction in line
 - *Location of Speed Control
- Control/Discharge Line
 - 2-way pilot control in line
 - *On/Off
 - *Variable restriction
 - Valve position varies or modulates
- Supply to Discharge relationship
 - Supply restriction is required for valve to regulate

3-Way Piping

- Operation
 - #1 – Routes fluid into cover-valve closed
 - #2 – Blocks supply – routes fluid out of cover-valve opens
 - Control typically used with low capacity pilots or valves smaller than 4"
 - *Solenoids
 - *Altitude
 - *Float
 - *Accelerator control
 - Used to increase capacity of 3-port controls

GUIDE TO TROUBLE SHOOTING PRESSURE REDUCING VALVES

PROPER START-UP

1. Valves should be started in a manner that allows for controlled pressurizing of the valve and the system.
 - a. The valve should be pressurized and vented.
 - i. Bleed the air off of the main valve cover
 - ii. Bleed the air off of the valve controls
 1. Trapped air will give a false reading unless it is eliminated.
 - b. Bring pilots into service with a pressure setting lower than that required.
 - i. Adjust to higher pressures as the system and valve stabilizes.
 - c. Pilot Adjustments.
 - i. Make all adjustments slowly, allowing for the control, valve and system to read the change
 - ii. Clockwise adjustments always increase the pressure setting.
 1. Turning the reducing control IN will INCREASE outlet pressure.
 2. Turning the relief/sustaining control IN will INCREASE the inlet or relief set-point.
 - iii. Counterclockwise adjustments always LOWER/DECREASE the pressure setting
 1. Turning the reducing control OUT will LOWER outlet pressure.
 2. Turning the relief/sustaining control OUT will LOWER the inlet or relief set-point.

ABOUT THE MAIN VALVE

1. Almost every function of control valve used in water applications call for a main valve flow of "under the seat".
 - a. If a diaphragm fails, the valve continues to allow flow.
 - i. Failure will be indicated by loss of pressure control or loss of positive shut-off

- b. Control circuit isolation ball valves can be used to isolate valve cover to allow for diaphragm condition check without removing the cover.
 - i. Close inlet ball valve
 - ii. Close cover ball valve
 - iii. Close outlet ball valve
 - iv. Bleed cover fluid
- c. Valve will open – fluid will continue to flow if diaphragm is damaged.

2. VALVE WILL NOT OPEN-CHECK PILOT SYSTEM

- a. Check opening speed control – OPEN.
- b. Check on/off devices.
 - i. Solenoid
 - ii. Deadman control
 - iii. Hydraulic check function
- c. Check system
 - i. For flow demand
 - ii. Inlet pressure
 - iii. Closed isolation valves
- d. Check function of hydraulic controls.
 - i. See pilot trouble shooting guidelines
 1. Take corrective action.

3. VALVE WILL NOT CLOSE

- a. Check pilot system.
 - i. Check closing speed control – OPEN
 - ii. Check on/of device for complete closing
 1. Solenoid
 2. Hydraulic check function.
 - iii. Check function of hydraulic controls
 1. See pilot trouble shooting guidelines.
 - a. Take corrective action.

4. VALVE WILL NOT REGULATE

- a. This is normally a problem with the hydraulic controls.
 - i. Check response to adjustments
 1. Service pilots as required.
 - ii. Check and adjust speed controls
 1. Gauge swings to higher than acceptable pressures.
 - a. Adjust for slower opening speed.
 - b. Adjust for faster closing speed.
 2. Gauge swings to lower pressures than acceptable.
 - a. Adjust for faster opening speed.
 - b. Adjust for slower closing speed.

ADJUSTABLE OPERATING RANGE	MINIMUM DEAD BAND.	PROOF PRESSURE	FACTORY SETTING
IPS40-1	9000104	1	10-175 PSI

Listing/Approvals: UL Standard 508 Guide (NKPZ) and CSA Standard C22.2 No. 14-M Class (321106) for Pressure Operated Industrial Control Equipment.

UL Standard 873 Guide (XAPX) and CSA Standard C22.2 No. 24 Class (481302) for Temperature Indicating and Regulating Equipment.

CE Marked

Ambient/Media Temperature Range:

-4°F to 180°F (-20°C to 82°C)

Construction:

- NEMA Type 4X Enclosure for indoor or outdoor use. (To maintain 4X rating, use appropriate Type 4 conduit hub.)
- Forged Brass or 316 S.S. Pressure Connections.
- Aluminum Diecast Base with Polymer Enclosure.
- Beryllium Copper Diaphragm (Stainless steel isolator diaphragm included for protection of beryllium copper diaphragm on models with stainless steel pressure connection.)
- Nitrile Pressure Sealing O-ring.

Switch Contact:

Snap Action SPDT (Form C)
 15 Amps at 125/250/480 VAC
 1/8 HP at 125 VAC
 1/4 HP at 250 VAC

General Description

The pressure switch is an Adjustable Deadband Pressure Switch with independent set and re-set points which are adjustable throughout the entire operating range of the switch. The minimum deadband (minimum span between set and reset points) may be obtained at any point in the operating range of the switch. A change in pressure greater than the high setting will reposition the switch mechanism to open or close a single snap-action electrical switch.

This control device is designed for use as an operating control in applications sensing air, water, or any fluid not harmful to the pressure connection, diaphragm or nitrile pressure sealing o-ring. Where an operating control would result in personal injury and/or loss of property, it is the responsibility of the installer to add devices (safety, limit controls) that protect against, or systems (alarm, supervisory systems) that warn of control failure.

This device is not intended for applications in explosive environments or use with hazardous fluids.

ADJUSTMENTS

The two thumb adjustment dials, accessible through the enclosure cover, are used to adjust the set point and reset point of the switch. The dial scales and pointer may be used to give an indication of the low and high set points.

The high setting adjustment dial is calibrated for increasing pressure. The low setting adjustment dial is calibrated for decreasing pressure. For best accuracy, make the final adjustments with a pressure gauge at the actual working media pressure and temperature encountered in the application.

The minimum deadband (minimum span between set and reset points) may be obtained at any point in the operating range of the switch.

When the desired settings are obtained, replace the adjustment cover. The adjustment cover and enclosure cover can be made tamper resistant by a single sealing wire inserted through the hole in the locking bar.

The repeatability of the set and reset points is typically $\pm 1\%$ of the operating range.

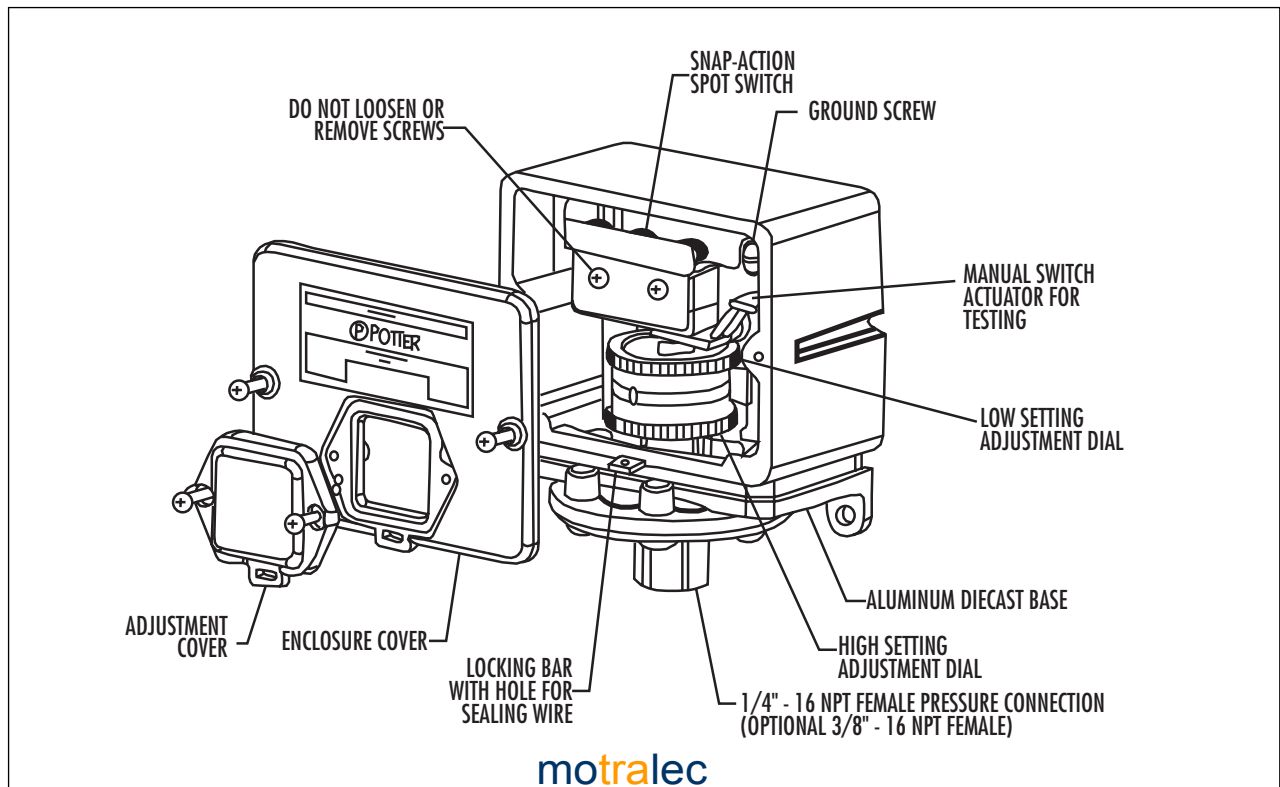

 4 rue Lavoisier . ZA Lavoisier . 95223 HERBLAY CEDEX
 Tel. : 01.39.97.65.10 / Fax : 01.39.97.68.48
 Demande de prix / e-mail : service-commercial@motralec.com
www.motralec.com