

ap

AURORA PUMP A member of PENTAIR PUMP GROUP

AURORA PUMP

BULLETIN 610M
610 SERIES
SINGLE STAGE
NON-CLOG PUMPS
"SPHER-FLO"

CAPACITIES TO 20000 G.P.M.
HEADS TO 250 FEET
TEMPERATURES TO 250°F
DISCHARGE SIZES 6" THRU 20"



MODEL 614A



MODEL 612A

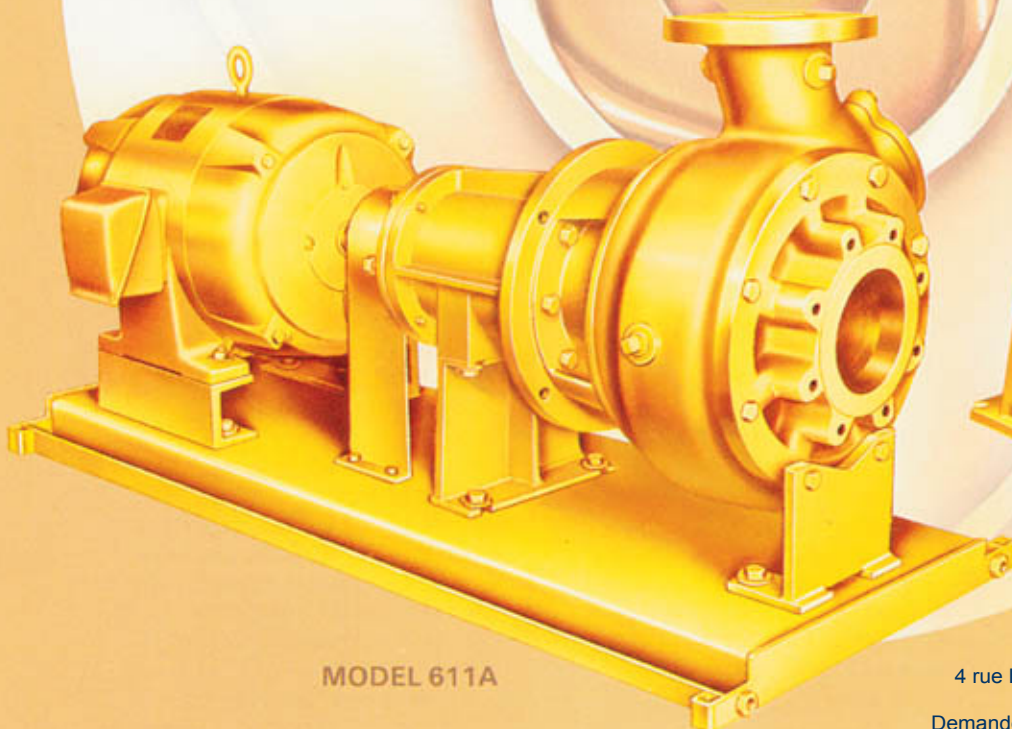

MODEL 611A



MODEL 613A

motralec

4 rue Lavoisier . ZA Lavoisier . 95223 HERBLAY CEDEX
Tel. : 01.39.97.65.10 / Fax. : 01.39.97.68.48
Demande de prix / e-mail : service-commercial@motralec.com
www.motralec.com

INTRODUCTION NON-CLOG PUMPS



MODEL 612A

The population explosion along with a broader understanding of the water pollution problem has brought about the need for more and better sewage treatment facilities. The installations of today and tomorrow demand more economical and reliable sewage pumping equipment. Longer life has become essential to overall pump performance. Aurora Pump has recognized the need for heavy duty, efficient, non-clog pumps for the wastewater industry. With over 45 years of experience, Aurora Pump is proud to present this bulletin featuring the new Series 610 Spher-Flo heavy duty horizontal and vertical non-clog pumps. This is the Aurora solution to wastewater pumping problems.

SPHER-FLO 610 SERIES PUMPS ARE AVAILABLE IN FOUR MODELS:
HORIZONTAL MODEL . . . 611A Page 5
VERTICAL MODEL . . . 612A Page 2
VERTICAL MODEL . . . 613A Page 9
VERTICAL MODEL . . . 614A Page 2



MODEL 614A

QUICK REFERENCE 610 SERIES *SPHER-FLO* NON-CLOG FEATURE SELECTOR

STANDARD

- 3" to 6" sphere capacity
- All iron fitted pump
- Regreaseable bearings
- 100,000 hour average bearing life
- Hardened stainless steel (450 min. Brinell) shaft sleeve (pumps with packing)
- External impeller clearance (cartridge type) adjustment
- Taper shaft fit at impeller
- Carbon steel shaft and impeller key
- Front or back impeller pullout
- Enclosed non-clog impeller
- Dynamically balanced impeller
- Centerline discharge casing
- Hydrostatic test all pumps
- Interchangeable packing and mechanical seal inserts
- Interwoven graphite/Teflon lubricated acrylic yarn packing, diagonally split
- Lantern ring liquid seal for packed stuffing boxes
- Gasket sealed pump shaft stuffing box extension
- Leakage accumulator packing gland (Power Frames 4, 5 & 6 only) (Models 612A and 613A)
- Suction elbow with clean out (Models 612A-613A-614A)
- Coupling Guard

OPTIONAL

- Stainless steel case wear ring
- Stainless steel impeller wear ring
- Single or Double mechanical seals
- Stainless steel shaft
- Alloy shaft sleeve (standard with mechanical seal)
- Impeller and case wear ring face flush line
- External stuffing box piping with filter or valve
- Automatic stuffing box grease seal lubricator
- Spacer type coupling (Horizontal Model 611A only)
- Flexible shaft drive with guard (Model 612A only)
- Water Seal Unit (Refer to Bulletin 680 for details)
- Constant liquid level system (Apco-Trol Variable Speed — Refer to the Apco-Matic Bulletin 700 for details)
- Certified test report — witnessed or unwitnessed
- Special alloy pump construction
- Alternate discharge positions
- Suction increasing elbow with clean out (Models 612A-613A-614A)
- Eccentric suction increasers (Model 611A)
- Removable split packing box

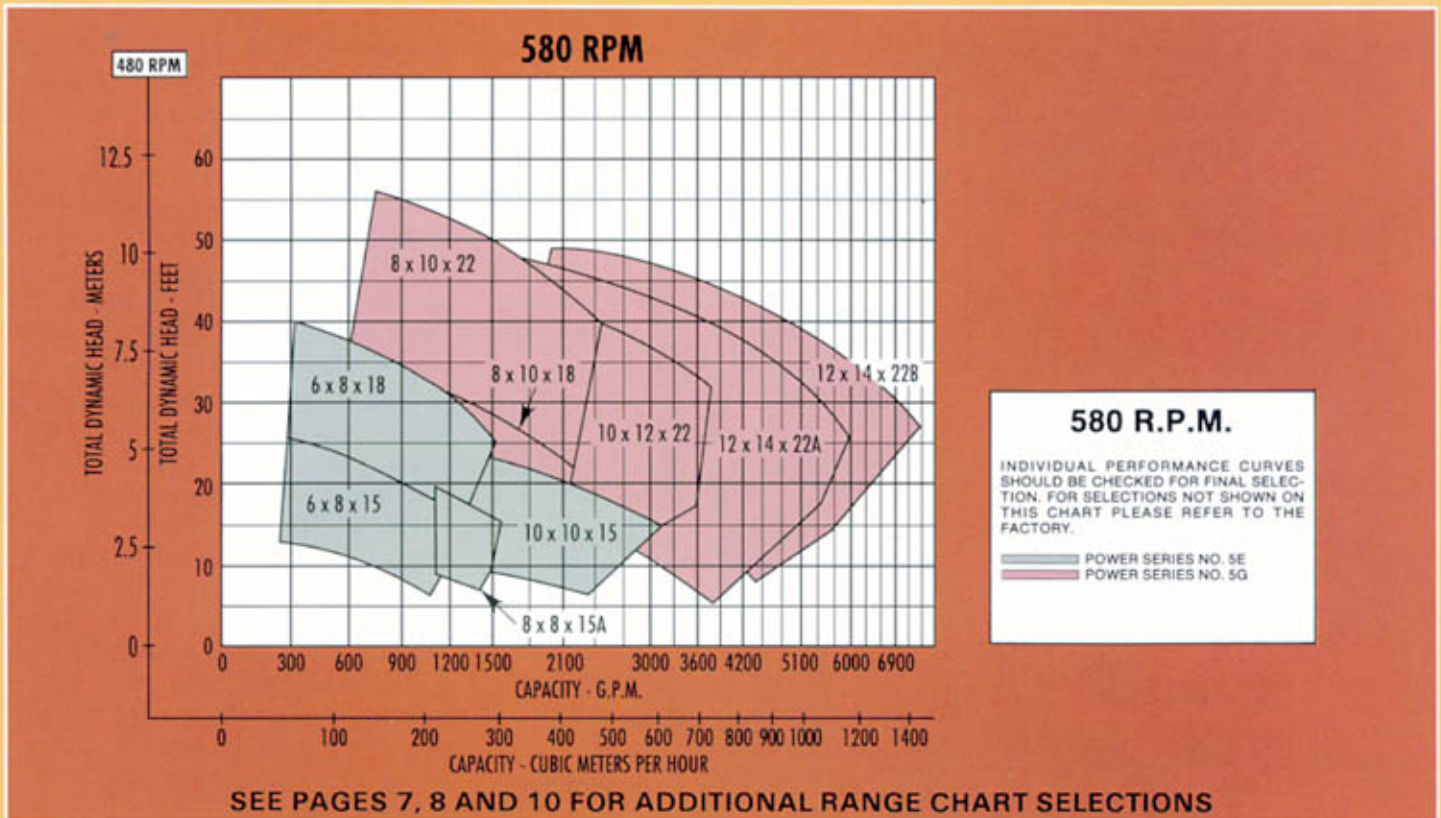

AURORA SPHER-FLO pumps are available for capacities to 20,000 gallons per minute and heads to 250 feet. The smallest pumps will pass a 3 inch diameter sphere and the largest passes a 7 inch diameter sphere. See factory for details. **1 EFFICIENT SKEWED VANE IMPELLER** provides smooth flow and maximum ability to avoid clogging. This design also minimizes operating noise. The

SPHER-FLO impeller is an exclusive Aurora hydraulic design. **2 CENTERLINE DISCHARGE CASINGS** are self venting and eliminate the need for left hand pumps. Oversize cleanout openings near the casing cutwater simplify cleaning. The minimum cleanout size is 3" x 5". The casing discharge can be mounted on 45° increments. **3 TAPERED IMPELLER FIT** assures tight impeller to shaft

and facilitates impeller removal. Back wiper vanes balance thrust bearing loads and prevent clogging behind impeller. Enclosed impeller provides highest efficiency and rugged construction for long service life and reliable pump operation. **BEARINGS** are selected for 2 year minimum life at worst conditions of load. Average bearing life is 10 years. See page 12 for additional bearing details.



SHAFT SEALS

EXCLUSIVE SPLIT PACKING BOX OPTION WITH LEAKAGE ACCUMULATOR IS AVAILABLE *ONLY* FROM AURORA PUMP. OPTIONAL: 611A-612A-613A-614A.

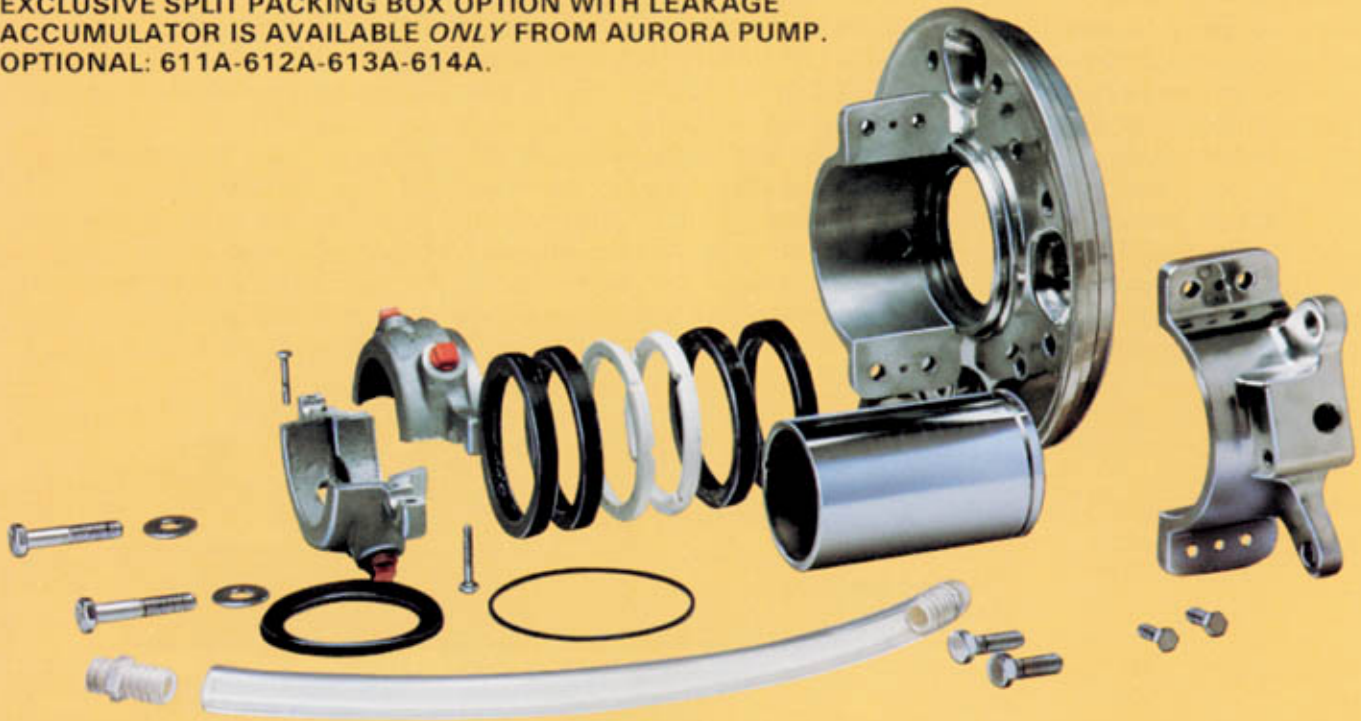

SPLIT PACKING BOXES separate vertically through the packing insert to simplify packing replacement and shaft sleeve inspection. The insert halves are doweled, aligned registered fit to prevent leakage. Only six bolts have to be removed to disassemble the

insert from the pump assembly. **DOUBLE MECHANICAL SEALS** must be recommended for gritty or abrasive applications. Seal faces are protected by clear water under pressure, injected directly into the seal cavity. The seal box design al-

lows speedy seal maintenance. Single mech. seals are available. **LEAKAGE ACCUMULATOR** for vertical pump models with packed stuffing boxes collects leakage for controlled drainage assuring effective odor control. The gland halves are dowel aligned.

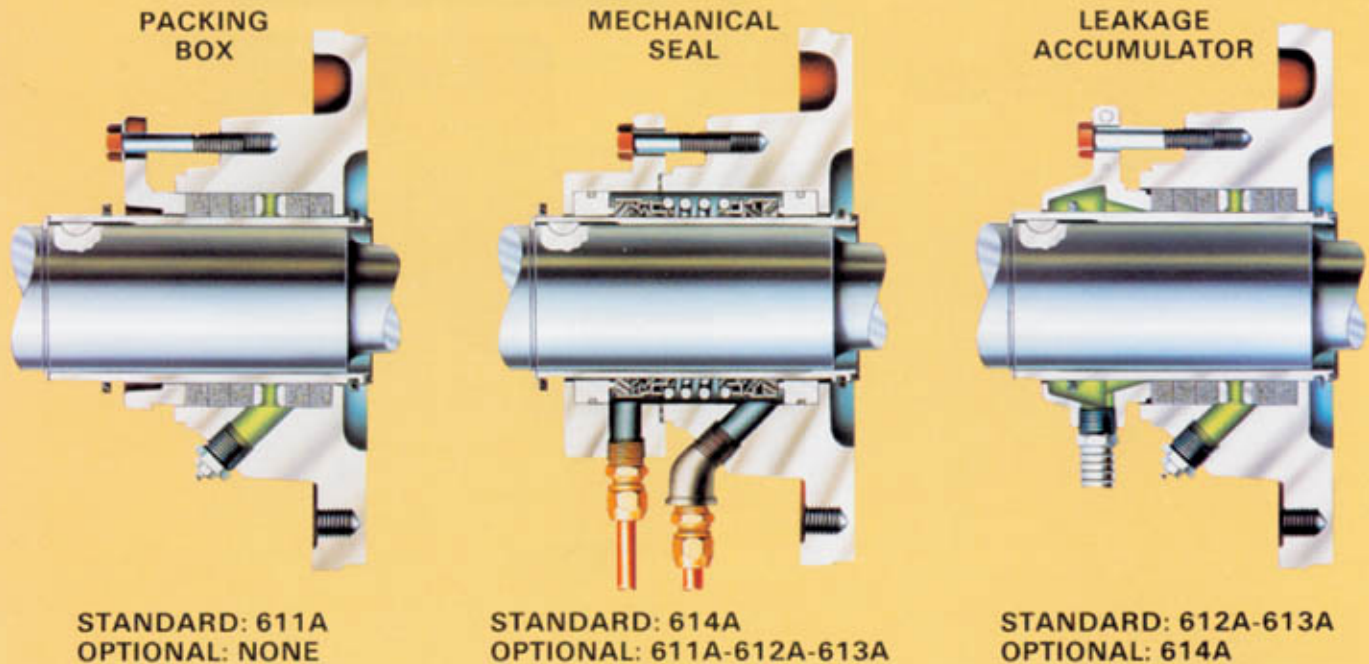

PUMP FEATURES

MODELS 611A are horizontally baseplate mounted with a driver flexibly coupled to the pump. This design is recommended where floor space is readily available and where flooding of the installation is not possible. SUPPORT of various pump components is important. Inadequate mounting designs impose unnecessary stress and strain on the pump installation. SPHER-FLO pumps are designed

to provide the best component support and serviceability, and is an important feature of the Aurora SPHER-FLO pump design. HORIZONTAL 611A UNITS are supported at both pump and coupling end. This, with center-line discharge support, provides protection against pipe strain and maintains casing support when the drive end of the pump is removed for servicing. The rear support foot greatly sim-

plifies shaft coupling alignment. Aurora Pump offers a complete line of vertical non-clog pumps. There are two distinct advantages over horizontal pump constructions:

- Less floor space required. Two vertical pumps will fit in the same space as one.
- An elevated motor will protect against potential flooding if the pump station location is in a low area.

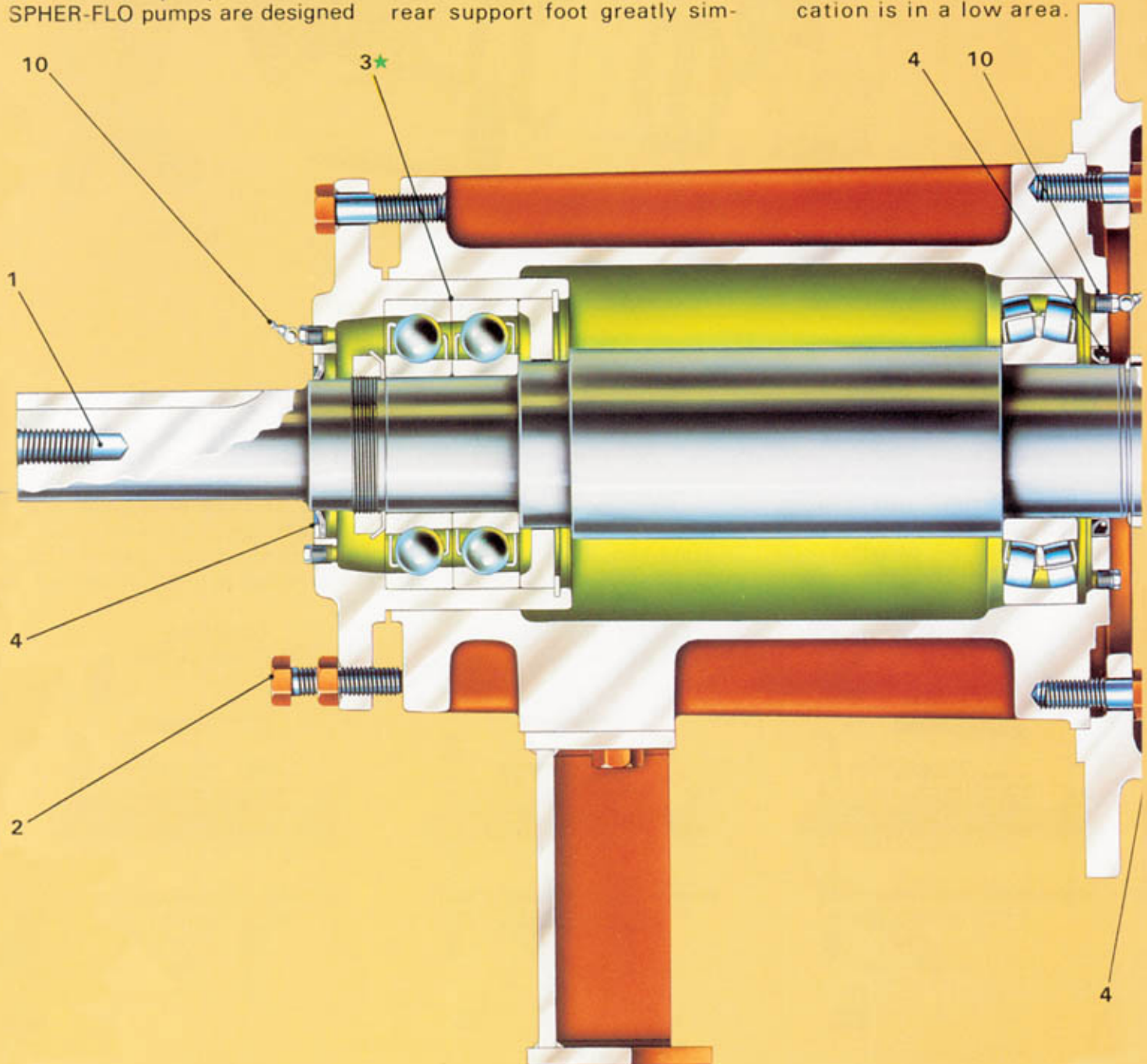

★ Power Series 4 has a single double row thrust bearing. The back to back thrust bearings illustrated are standard on Power Series 5 and 6.

HORIZONTAL
MODEL 611A
ILLUSTRATED

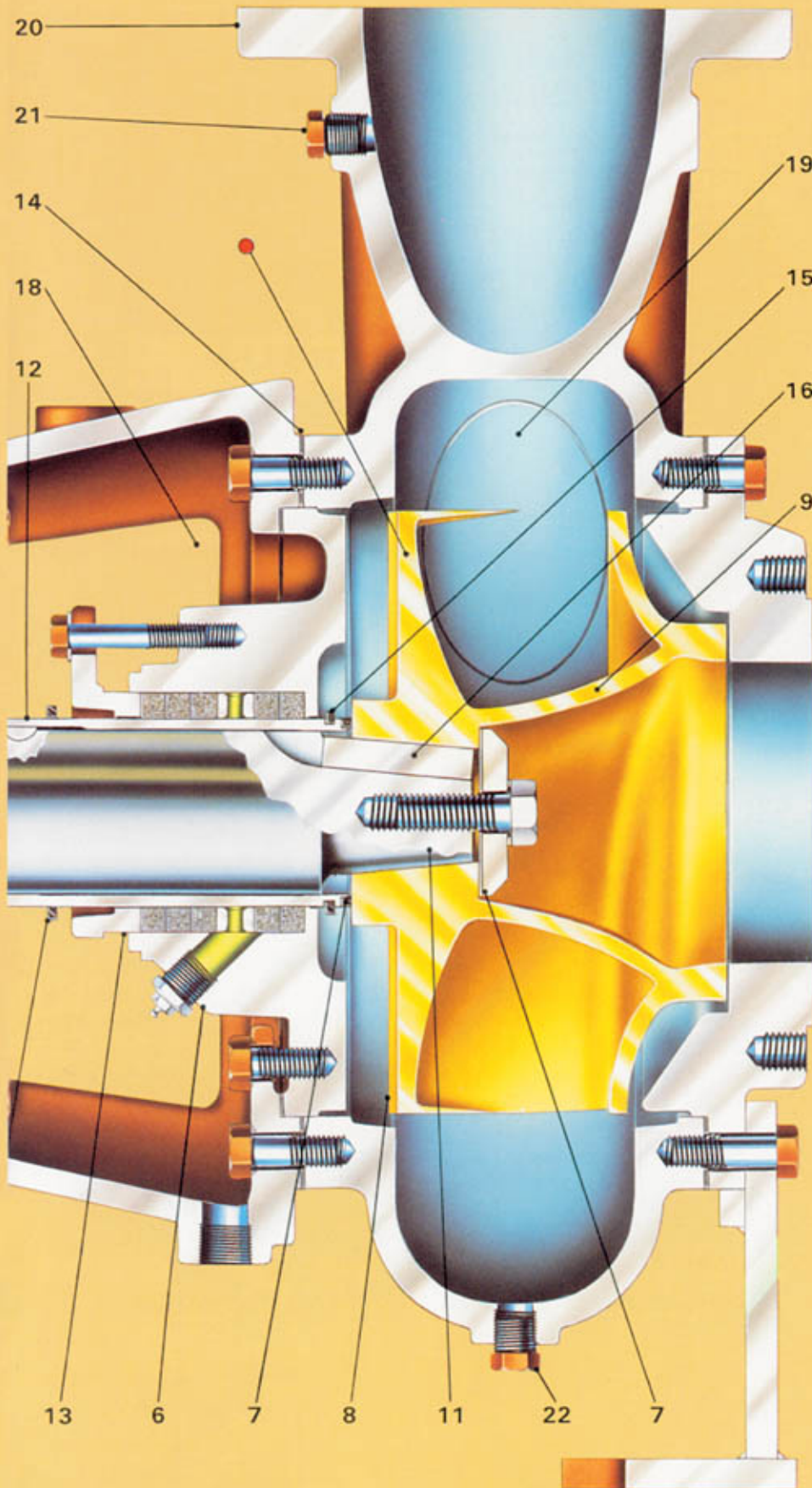

● = OPTIONAL ALL BRONZE IMPELLER IS ILLUSTRATED. STANDARD MATERIAL IS IRON.

MODELS 612A are vertically mounted and utilize flexible shafting between the driver and the pump. Vertically mounted models are frequently used on lift station applications where flooding of the installation is a possibility. MODELS 613A are vertically mounted with an elevated driver coupled directly to the pump thru a flexible coupling. Model 613A is very popular for installations where available floor space is limited and where flooding is marginal. Model 614A driver couples directly to the pump. On VERTICAL 613A UNITS, the steel motor base has a registered fit at the motor end and is fastened to a separate motor support. This arrangement assures alignment and concentrates loads on the separate pump adapter thereby eliminating strain and misalignment of the bearing housing. This is another exclusive feature of the Aurora SPHER-FLO pump. On 612A, 613A & 614A UNITS a steel suction base is registered to the suction cover assuring adequate support for the pump unit. STANDARD "SPHER-FLO" PUMPS are designed for the requirements of the majority of applications. However, to meet special requirements, a number of optional features are available. For requirements not handled by the following list of options refer to the local sales office.

SUCTION NOZZLES for Model 611A series pumps have hand-size inspection openings to allow access to the impeller.

REPLACEABLE WEAR RING available individually or together, protects the impeller and/or casing from wear.

SPACER COUPLINGS are recommended for horizontal pump applications where it is desirable to remove the bearing assembly without disturbing the pump casing or motor.

SHAFT AND SLEEVE are available in special alloy construction for difficult pumping applications.

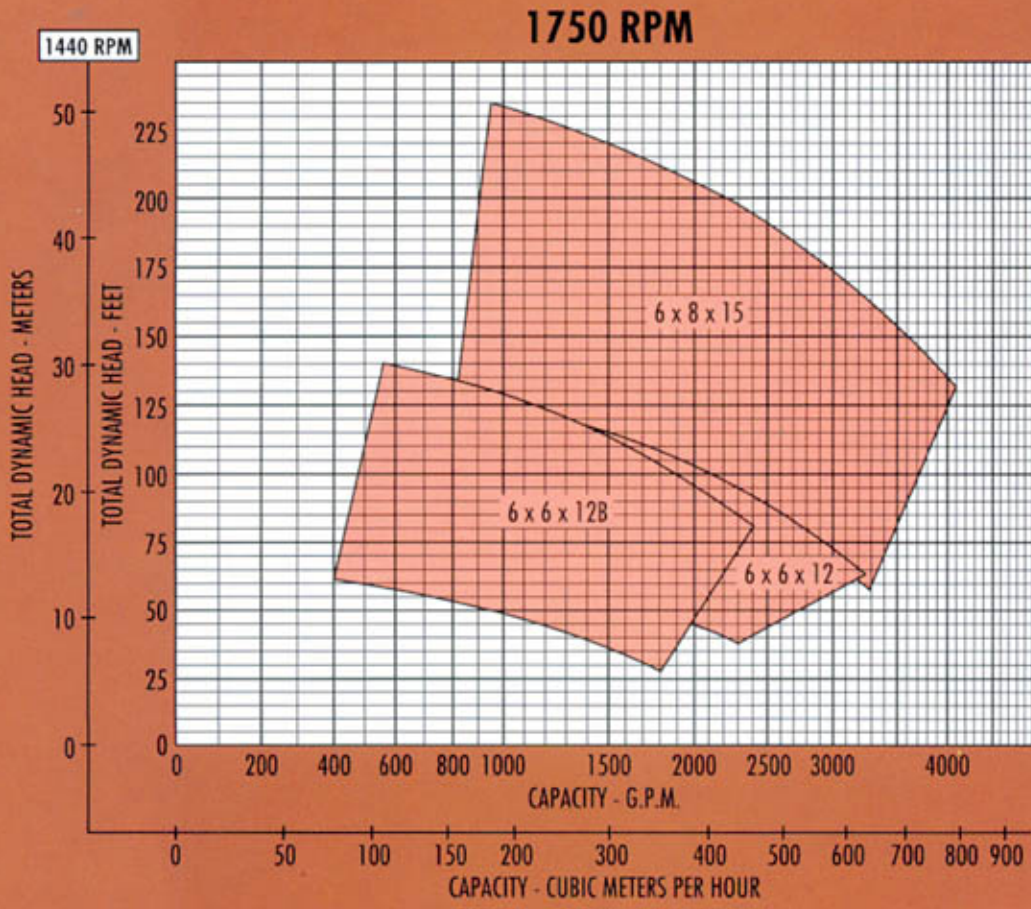

1750 R.P.M.

INDIVIDUAL PERFORMANCE CURVES SHOULD BE CHECKED FOR FINAL SELECTION. FOR SELECTIONS NOT SHOWN ON THIS CHART PLEASE REFER TO THE FACTORY.

POWER SERIES NO. 5F

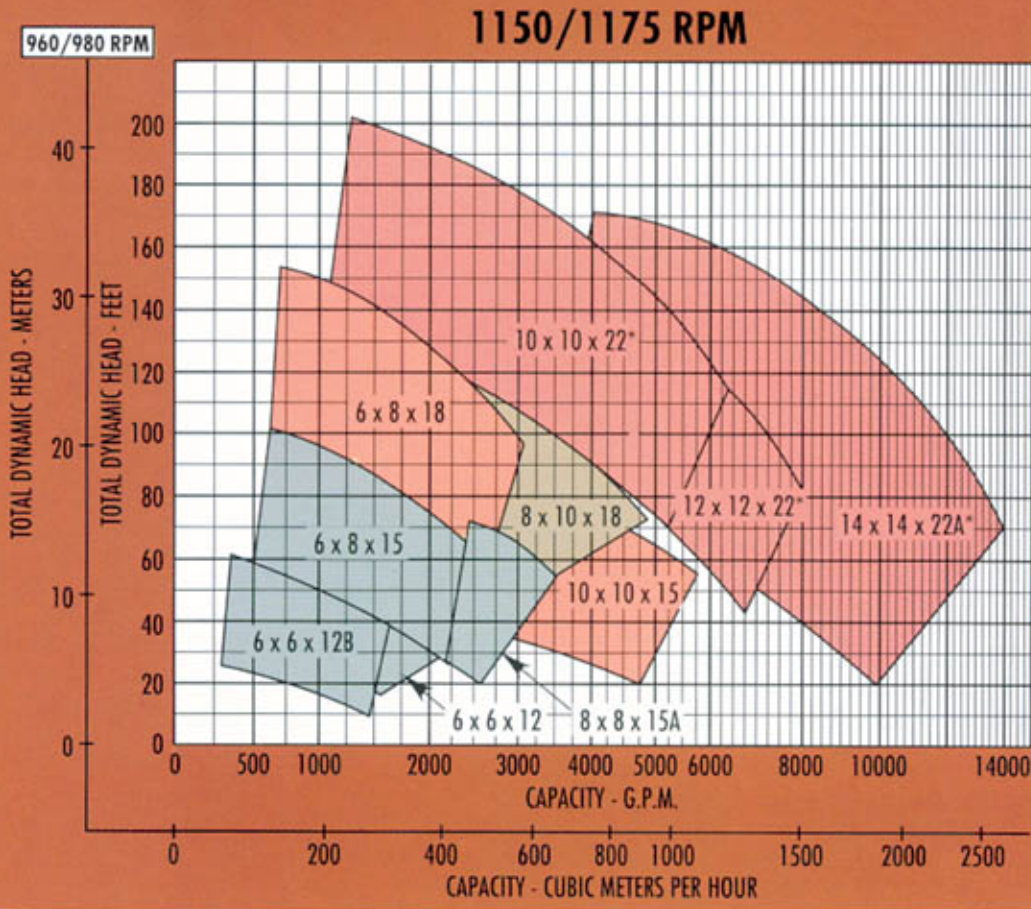

1150/1175* R.P.M.

INDIVIDUAL PERFORMANCE CURVES SHOULD BE CHECKED FOR FINAL SELECTION. FOR SELECTIONS NOT SHOWN ON THIS CHART PLEASE REFER TO THE FACTORY.

POWER SERIES NO. 5E
 POWER SERIES NO. 5F
 POWER SERIES NO. 5H
 POWER SERIES NO. 6E

RANGE CHARTS

6"-8"-10"-12"-14" PUMPS

875 RPM

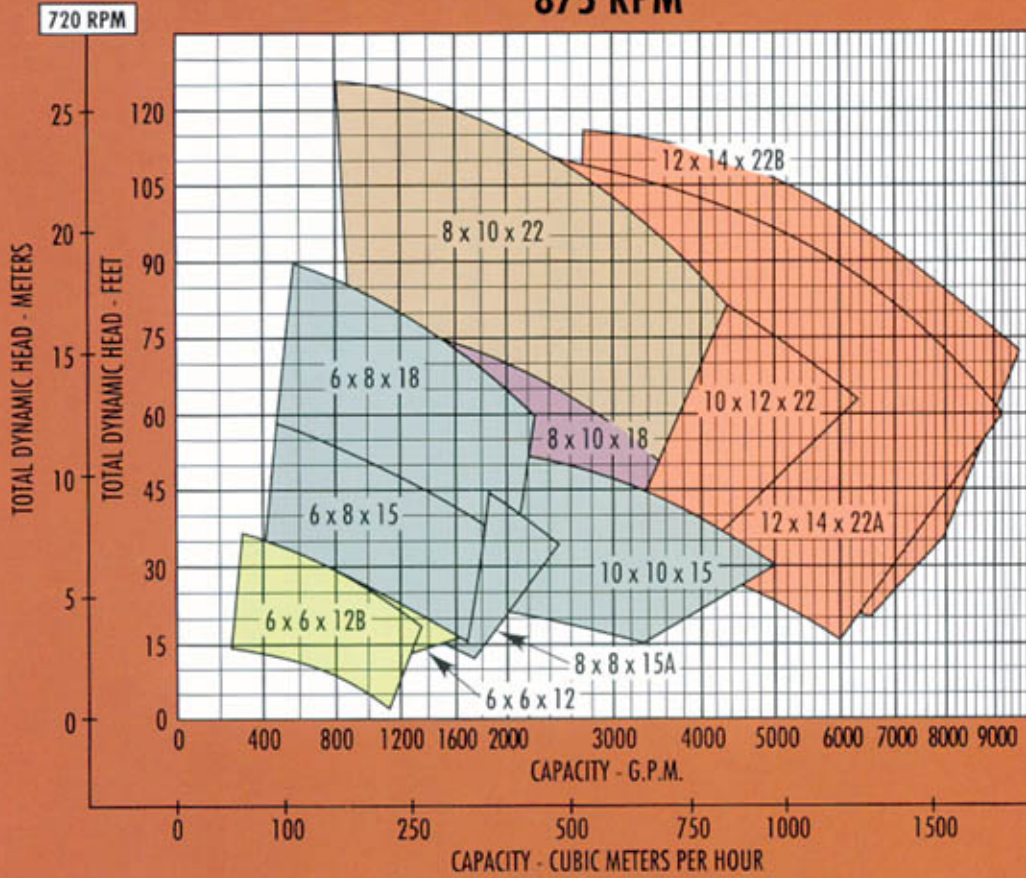

875 R.P.M.

INDIVIDUAL PERFORMANCE CURVES SHOULD BE CHECKED FOR FINAL SELECTION. FOR SELECTIONS NOT SHOWN ON THIS CHART PLEASE REFER TO THE FACTORY.

- POWER SERIES NO. 4C
- POWER SERIES NO. 5E
- POWER SERIES NO. 5G
- POWER SERIES NO. 5H
- POWER SERIES NO. 5H
- POWER SERIES NO. 6D
- POWER SERIES NO. 6D

700 RPM

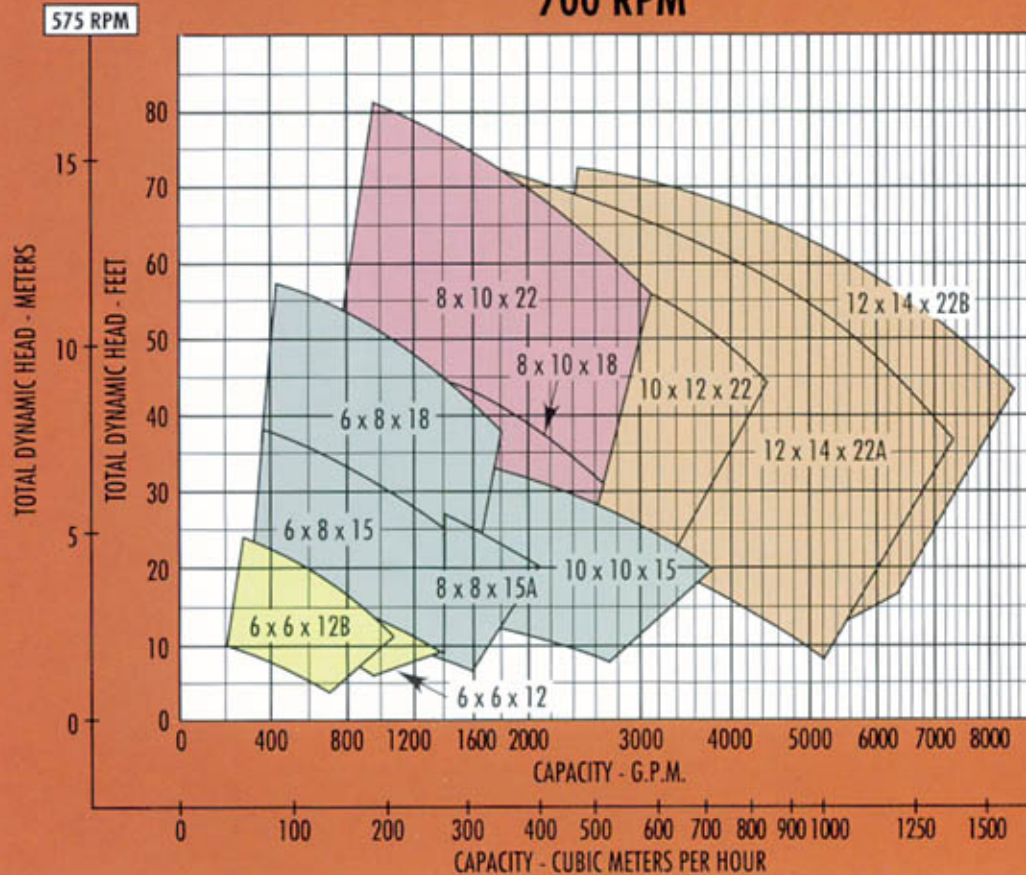

700 R.P.M.

INDIVIDUAL PERFORMANCE CURVES SHOULD BE CHECKED FOR FINAL SELECTION. FOR SELECTIONS NOT SHOWN ON THIS CHART PLEASE REFER TO THE FACTORY.

- POWER SERIES NO. 4C
- POWER SERIES NO. 5E
- POWER SERIES NO. 5G
- POWER SERIES NO. 5H
- POWER SERIES NO. 5H
- POWER SERIES NO. 6D
- POWER SERIES NO. 6D

1 LIFTING EYE tap in shaft end simplifies disassembly.

2 EXTERNAL SHAFT ADJUSTMENT provides for renewing impeller clearance and maintaining pump efficiency.

3 DOUBLE ROW THRUST BEARINGS are added protection for high loads. Average bearing life is 10 years.

4 WATER SLINGER, and grease seals protect both bearings from moisture.

5 LEAKAGE ACCUMULATOR GLAND option to siphon off packing leakage.

6 STUFFING BOXES are machined for mechanical seals or packing. Either may be used without modification.

7 GASKETS protect shaft from pumped liquid corrosion and contamination.

8 IMPELLER WIPER VANES minimize stuffing box pressure and clogging.

9 IMPELLER VANES brought well into the inlet eye to pick up liquid early and to minimize clogging.

10 GREASE LUBRICATION purges old grease from both bearings.

11 RUGGED SHAFT with taper for easy impeller removal and minimum deflection.

12 HARDENED STAINLESS STEEL SLEEVE on packed pump is securely key locked to the shaft.

13 .002 MAXIMUM SHAFT DEFLECTION at stuffing box face extends packing and mechanical seal life.

14 BACK PULLOUT DESIGN for pump maintenance, does not disturb suction or discharge piping.

15 SNAP RING groove is provided for a snap ring to aid in sleeve removal during preventative maintenance period.

16 STEEL IMPELLER KEY, capscrew and washer secures impeller to shaft.

17 NEMA STANDARD "HP" mounting face and shaft extension motors.

18 LARGE ACCESS OPENINGS provide adequate visibility and working room.

19 OVAL CLEANOUTS are large, HAND SIZE and located to provide visibility and accessibility to the impeller blades and the casing cutwater.

20 DISCHARGE flanges can be located in 45° increments for 8 different positions. (suction in 90°-vertical pumps)

21 STANDARD GAUGE TAPS are conveniently located at both the discharge and suction flange openings.

22 STANDARD DRAIN TAPS are located conveniently in the adapter bracket, suction elbow, and casing.

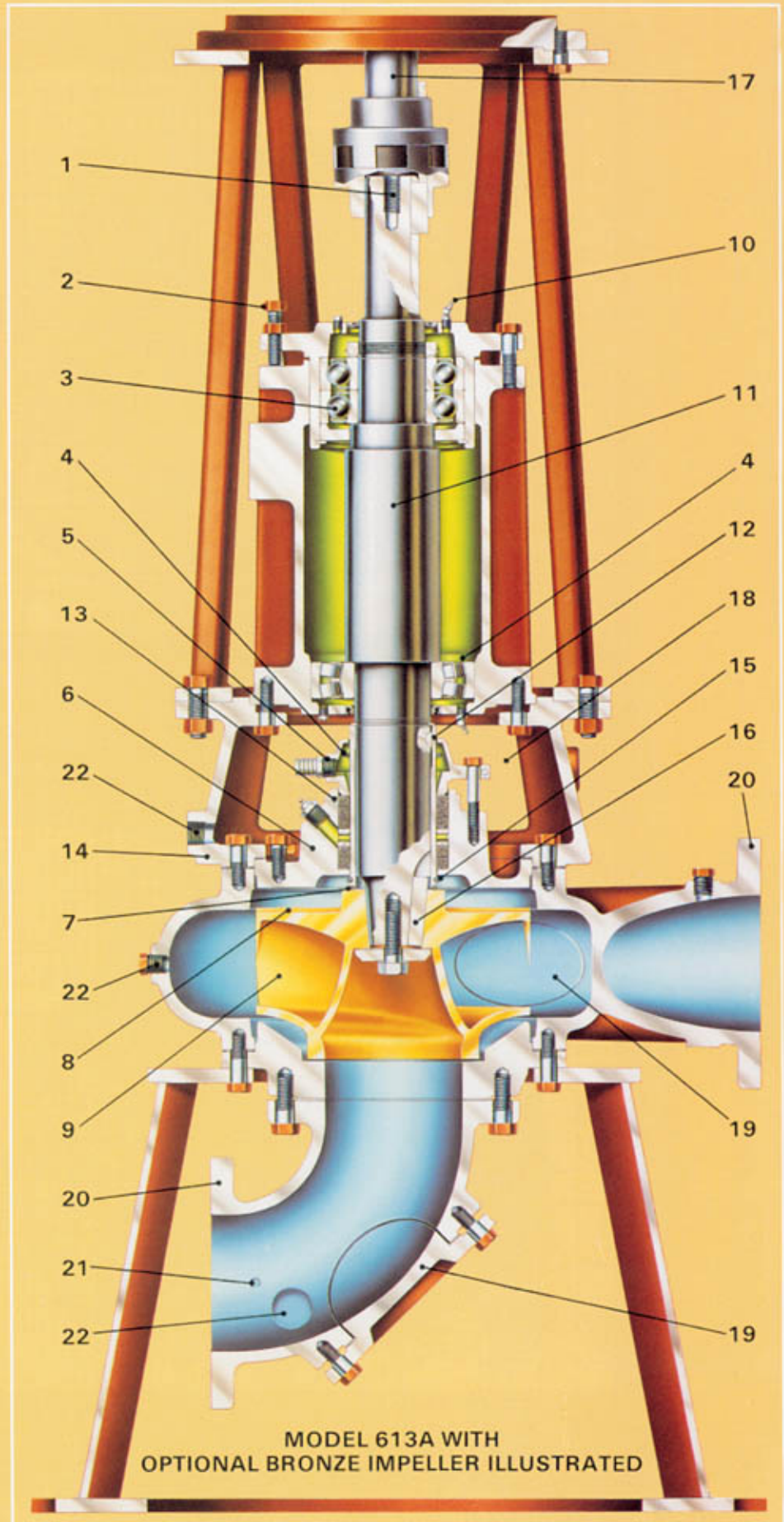

**MODEL 613A WITH
OPTIONAL BRONZE IMPELLER ILLUSTRATED**

RANGE CHARTS

16"-18"-20" PUMPS

INDIVIDUAL PERFORMANCE CURVES SHOULD BE CHECKED FOR FINAL SELECTION. FOR SELECTIONS NOT SHOWN ON THIS CHART PLEASE REFER TO THE FACTORY.

POWER SERIES NO. 6P
POWER SERIES NO. 8

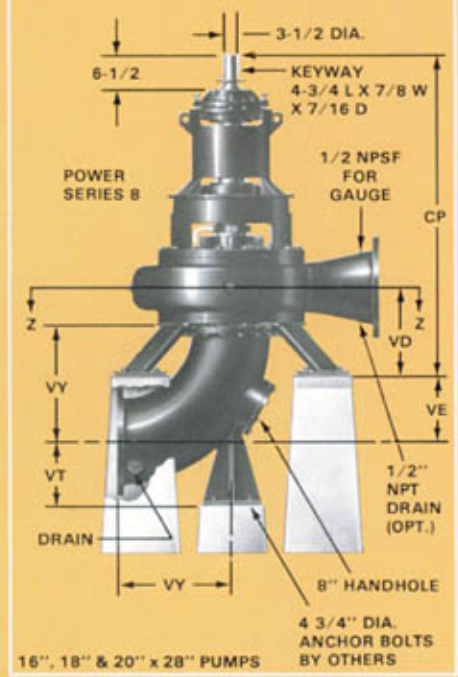
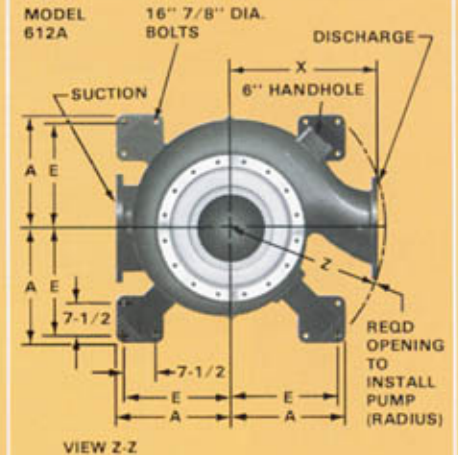
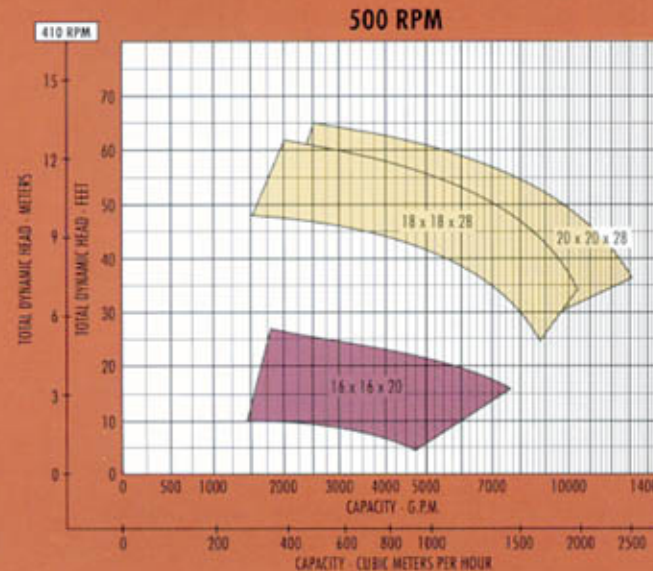
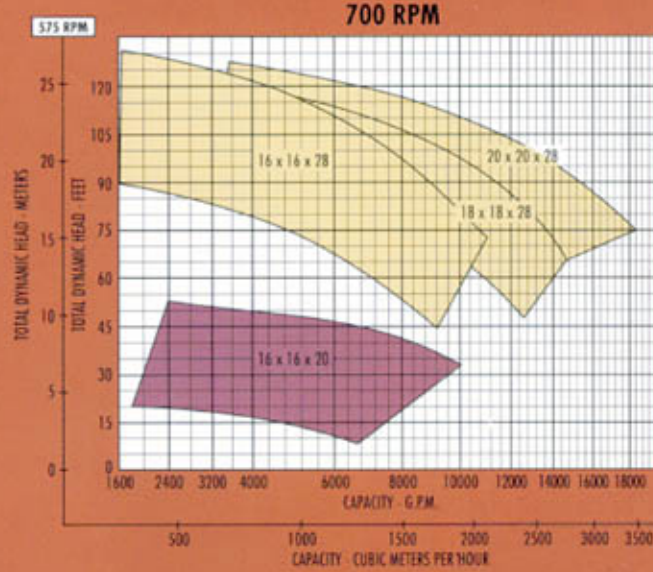
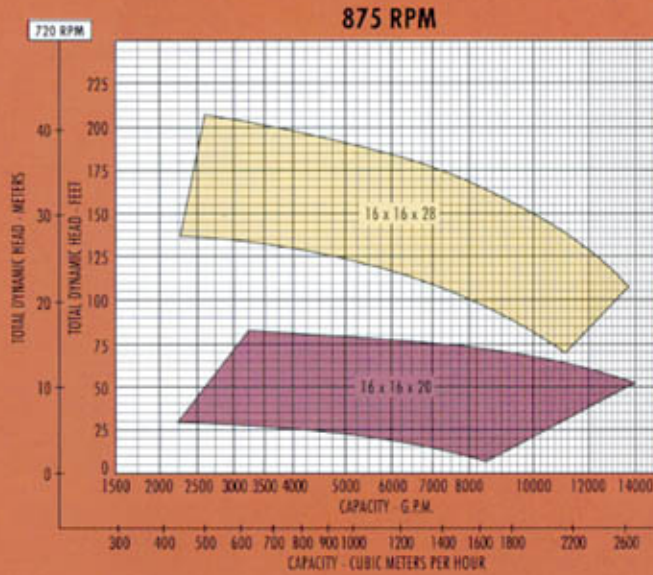

NOTES: 1. Dimensions and weights are approximate. 2. Refer to factory for base dimensions when spacer couplings are specified. 3. Not for construction purposes unless certified. 4. Frame sizes shown are for open dripproof motors only. 5. Conduit box is shown in approximate position. Dimensions are not specified as they vary with each motor manufacturer. 6. Add pump, base and motor weight for unit weight. 7. Discharge position 1 is shown. Alternate discharge positions are available. 8. Refer to factory for Model 614A weight.

CASE BORE	16 x 16 x 28	18 x 18 x 28	20 x 20 x 28
SUCT.			
DISCH.			
A	26-1/2	26-1/2	26-1/2
E	24-3/4	24-3/4	24-3/4
X	34	37	42
Z	36	39	44-1/4
CP	74-1/2	78	77-11/16
VD	20-1/8	22-7/8	22-1/16
SUCT. ELBOW	16 x 16	18 x 18	20 x 20
VE	12-15/16	14-1/8	21-15/16
VT	13-3/4	15	16
VY	24	26-1/2	29

PUMP DIMENSIONS

611A - 612A - 613A - 614A DIMENSIONS - PUMP																		
PUMP SIZE		CASE BORE	POWER FRAME	PUMP WEIGHT			CP							VD	VE	VY		
DISCH	SUCT			611A	612A	613A	A	D	U	X	Y	611A	612A				613A	614A
6	6	12	4C-D	580	830	1080	34	13-1/2	1-1/4	14	6-3/16	29-1/2	47-11/16	52-3/16	34-1/8	24-5/16	10-1/8	8
			5F	845	1100	1325	24	13-1/2	2-3/8	14	6-3/16	40-3/8	58-9/16	64-1/8	35-1/4	24-5/16	10-1/8	8
6	6	12B	4C-D	580	830	1080	24	13-1/2	1-1/4	16	6-1/16	29-1/2	47-11/16	52-3/16	34-1/8	24-1/16	10-1/8	8
			5F	845	1100	1325	24	13-1/2	2-3/8	16	6-1/16	40-3/8	58-9/16	64-1/8	35-1/4	24-1/16	10-1/8	8
6	8	15	5E-F	850	1100	1350	30	15-1/4	2-3/8	16	6-1/8	29-7/8	65-7/8	71-7/16	38-1/2	32-1/8	17	9
			5E-F	915	1235	1630	30	17-1/2	2-3/8	18	6-7/16	40-1/2	66-1/2	72-1/16	—	32-3/8	17	9
8	8	15A	5E	920	1245	1470	30	15-1/4	2-3/8	19	9-1/8	43-1/4	66-1/2	72-1/16	32-3/8	32-3/8	14-1/4	9
			5G-H	1055	1375	1675	30	17-1/2	2-3/8	19	6-3/4	41-3/8	67-5/8	73-3/16	—	32	16	11
8	10	22	5G-H	1260	1930	2220	37	21	2-3/8	22	6-7/8	41-1/2	69-1/8	74-11/16	—	34-1/2	16-5/8	11
			5E-F	925	1510	1830	30	16-1/4	2-3/8	20	10-1/16	44-7/8	67-5/8	73-3/16	44	32-15/16	11-7/8	11
10	10	22	6E	1430	2100	—	37	21	2-7/8	22	6-7/8	44	71-5/8	77-3/16	—	34-1/2	16-5/8	11
			5G-H	1390	2060	2360	37	21	2-3/8	22-1/2	7-3/16	42-1/4	70-1/4	75-13/16	—	35-1/8	15-9/16	12
12	12	22	6D	1510	2180	2480	37	21	2-7/8	22-1/2	7-3/16	44-3/4	72-3/4	78-5/16	—	35-1/8	15-9/16	12
			6E	1560	2230	—	37	21	2-7/8	22-1/2	7-1/4	44-3/8	72-3/4	78-5/16	—	35-1/8	15-9/16	12
12	14	22	5G-H	1460	2135	2435	37	21	2-3/8	24	7-1/4	42-3/8	70-1/4	75-13/16	—	35-1/8	13-7/8	14
			6D	1580	2250	2550	37	21	2-7/8	24	7-1/4	44-3/8	72-3/4	78-5/16	—	35-1/8	13-7/8	14
14	14	22A	6E	1620	2300	—	37	21	2-7/8	24	7-1/4	44-3/8	72-3/4	78-5/16	—	35-1/8	13-7/8	14
			6F	2500	—	—	—	24	2-7/8	32	23-1/2	63-3/8	—	—	—	—	—	—

611A - DIMENSIONS - BASE							
PUMP SIZE	MOTOR FRAMES	HA	HB	HG	HO	HY	BASE WGT.
6x6x12	254T-286T	20	66	1-1/2	32	10	131
	324T	25-5/8	72	2	32	7	272
	284T-305T	25-5/8	72	2	32	7	272
6x6x12B	254T-286T	20	66	1-1/2	32	10	131
	324T	25-5/8	72	2	32	7	272
	284T-305T	25-5/8	72	2	32	7	272
6x8x15	284T-305T	25-5/8	72	2	36	8	272
	404T-405T	29-5/8	82	2	35	8	437
	444T-445T	29-5/8	90	2	35	8	477
6x8x18	284T-305T	25-5/8	72	2	40	9	272
	404T-405T	29-5/8	82	2	40	9	437
	444T-445T	29-5/8	82	2	40	9	437
8x8x15A	256T-326T	25-5/8	82	2	36	9	272
	364T-365T	29-5/8	74	2	36	9	381
	404T-405T	29-5/8	82	2	36	9	437
8x10x18	284T-326T	25-5/8	72	2	41	9	272
	364T-365T	29-5/8	74	2	41	9	381
	404T-444T	29-5/8	82	2	41	9	437
8x10x22	445T & LGR	29-5/8	90	2	41	9	477
	324T-326T	29-5/8	74	2	47	12	381
	364T-405T	29-5/8	82	2	47	12	437
10x10x15	444T & LGR	29-5/8	90	2	47	12	477
	364T-444T	29-5/8	82	2	29	9	437
	445T & 365TS	29-5/8	90	2	29	9	477
10x10x22	445T & LGR	37	110	2	48	13	735
	364T-365T	29-5/8	74	2	48	13	381
	404T-405T	29-5/8	82	2	48	13	437
10x12x22	444T-445T	29-5/8	90	2	48	13	477
	404T-405T	29-5/8	82	2	48	13	437
	444T-445T	29-5/8	90	2	48	13	477
12x12x22	445T & LGR	37	110	2	48	13	735
	364T-365T	29-5/8	74	2	49	13	381
	404T-405T	29-5/8	82	2	49	13	437
12x14x22 A & B	444T-445T	29-5/8	90	2	49	13	477
	404T-405T	29-5/8	82	2	49	13	437
	444T & LGR	29-5/8	90	2	49	13	477
14x14x22A	445T & LGR	37	110	2	50	13	735
	364T-365T	29-5/8	82	2	60-1/2	11-1/2	437
	404T-405T	29-5/8	90	2	60-1/2	11-1/2	477
16x16x20	444-445T	29-5/8	90	2	60-1/2	11-1/2	477
	445T & LGR	37	110	2	61	11-1/2	735

MOTOR FRAME*	HORSE POWER AT RPM				MOTOR WGT. IN LBS.	C	AG
	1750	1150	875	700			
184T	5	—	—	—	85	14	14
213T	7-1/2	—	—	—	150	16	16
215T	10	5	—	—	190	18	17
254T	15	7-1/2	—	—	230	21	19
256T	20	10	7-1/2	5	250	23	21
284T	25	15	10	7-1/2	350	24	22
286T	30	20	15	10	380	25	23
324T	40	25	20	15	475	26	24
326T	50	30	25	20	525	28	26
364T	—	40	30	25	630	29	25
364TS	60	—	—	—	630	27	25
369T	—	50	40	30	690	30	25
365TS	75	—	—	—	690	28	25
404T	—	60	50	40	830	33	28
404TS	100	—	—	—	830	30	28
405T	—	75	60	50	915	34	28
405TS	125	—	—	—	915	31	28
444T	—	100	75	60	1000	38	32
444TS	150	—	—	—	1000	34	32
445T	200	125	100	75	1100	40	32
250	150	125	100	—	—	—	—

*NOTE: Frame sizes listed are for O.D.P. motors. Model 611A pumps use "T" frame motors. Models 612A and 613A use "HP" frame motors. Model 614A pumps use "TCV" frame motors.

LIMITATIONS
 Maximum hydrostatic test pressure 125 PSI++
 Maximum recommended case work pressure 100 PSI++
 Maximum suction pressure 100 PSI++
 Maximum temperature packing 250° F
 Maximum temperature mechanical seal 225° F
 Maximum operation speed 1800 RPM
 ++For pump size 6 x 8 x 15 at 1750 RPM with shut-off TDH greater than 231 feet the following limitations apply:
 1. Maximum hydrostatic test pressure 150 PSI
 2. Maximum recommended case working pressure 125 PSI
 3. Maximum suction pressure 125 PSI

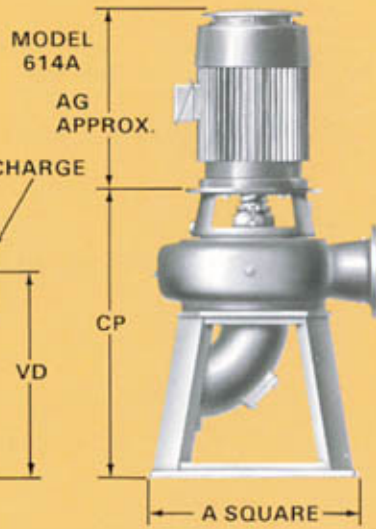
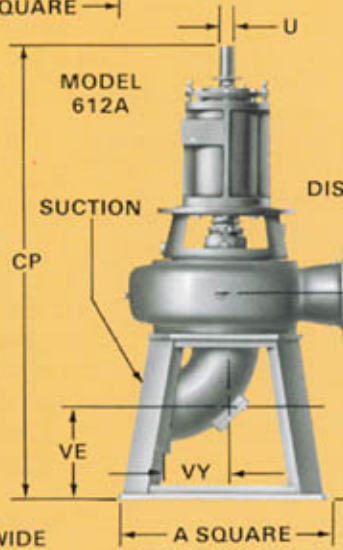
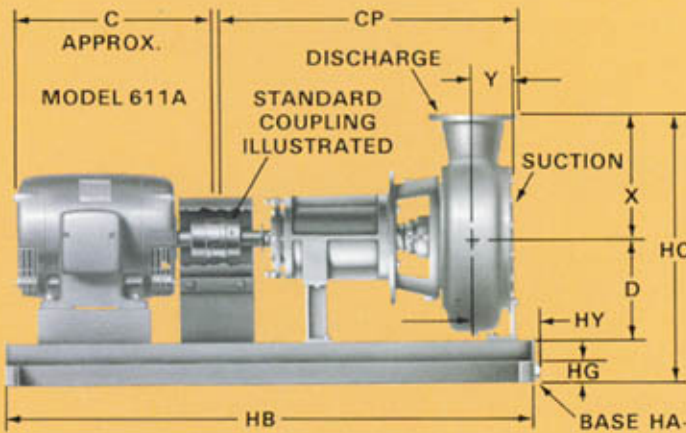
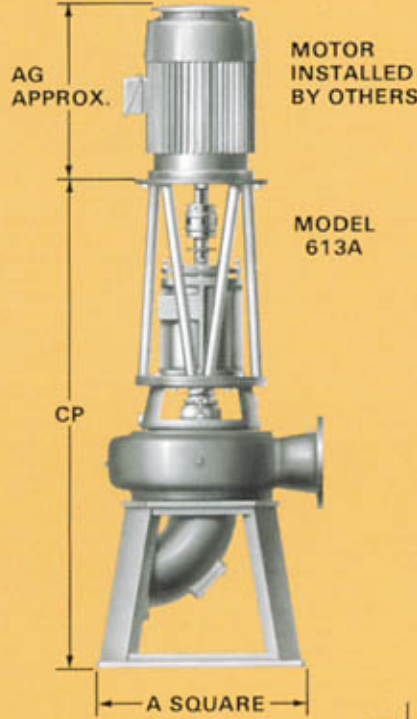

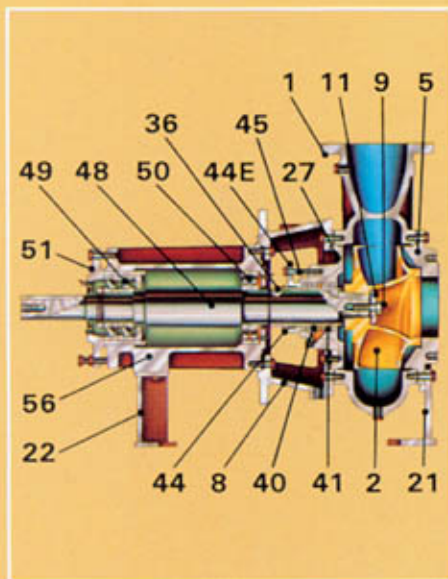

AREA	DESCRIPTION	POWER SERIES								*Indicates Back to Back Bearings Quantity 2.	
		4C	4D	5E	5F	5G	5H	6D-6F	6E		8
STUFFING BOX	Stuffing Box Bore Dia	3-9/32	3-9/32	4-25/32	4-25/32	4-25/32	4-25/32	6-25/32	6-25/32	8-17/32	
	Stuffing Box Depth	2-3/4	2-3/4	3-1/2	3-1/2	3-1/2	3-1/2	5-1/4	5-1/4	8-1/8	
	Outside Dia. Sleeve for Packing	2-1/2	2-1/2	3-3/4	3-3/4	3-3/4	3-3/4	5-1/4	5-1/4	7	
	Total No. of Pack. Rings w/ Lantern Ring	5	5	5	5	5	5	5	5	5	
	No. of Rings in Front of Lantern Ring	2	2	2	2	2	2	2	2	2	
	Packing Size	3/8 x 3/8		1/2 x 1/2		1/2 x 1/2		3/4 x 3/4		3/4 x 3/4	
	Width of Lantern Ring	5/8	5/8	3/4	3/4	3/4	3/4	1-1/8	1-1/8	1-1/8	
	Distance from Box to Nearest Obstruction	2-15/16	2-15/16	2-3/4	2-3/4	2-3/4	2-3/4	3-5/16	3-5/16	2-1/2	
	Length of Mech. Seal	REFER TO FACTORY									
	Outside Dia. Sleeve for Mechanical Seal	2-1/4	2-1/4	3-5/8	3-5/8	3-5/8	3-5/8	5	5	N/A	
SHAFT	Diameter at Impeller (Taper Average)	1-7/16	1-7/16	2-1/4	2-1/4	2-7/8	2-7/8	2-7/8	2-7/8	3-1/2	
	Dia. at Shaft Sleeve	1-7/8	1-7/8	3-1/4	3-1/4	3-1/4	3-1/4	4-1/2	4-1/2	6	
	Dia. Between Bearings (Max. Shaft Dia.)	3-5/16	3-5/16	4-1/8	4-1/8	4-1/8	4-1/8	5-1/4	5-1/4	7-1/2	
	Dia. at Coupling End	1-1/4	1-1/4	2-3/8	2-3/8	2-3/8	2-3/8	2-7/8	2-7/8	3-1/2	
	Maximum Deflection at Stuffing Box Face	.002	.002	.002	.002	.002	.002	.002	.002	.002	
BEARINGS	Bearing Number (Inboard Radial)	6311	21311	6317	21317	6317	21317	23024	22224	22332	
	Bearing Number (Outboard Thrust)	3309	3309	7315*	7315*	7315*	7315*	7222*	7322*	22326	
	Bearing Centers	7-3/4	7-3/4	12-11/16	12-11/16	12-11/16	12-11/16	12-5/8	12-3/4	21	
	Min. Life of Brg. Under Worst Conditions of Load in Years (2)	2	2	2	2	2	2	2	2	2	

PC NO.	DESCRIPTION	FITTED	MAT'L OF CONST.
1	Casing	Iron	Cast Iron ASTM A48
2	Impeller	Iron	Cast Iron ASTM A48
+3	Wear Ring (Impeller)	Iron	Stainless Steel AISI 420
5	Cover	Iron	Cast Iron ASTM A48
+6	Wear Ring (Cover)	Iron	Stainless Steel AISI 420
8	Bracket	Iron	Cast Iron ASTM A48
9	Imp. Screw	Iron	Cadmium Plated Steel
11	Washer	Iron	Steel
21	Support	Iron	Steel ASTM A-36
22	Support - 611A	Iron	Steel ASTM A-36
+22	Motor Support - 613A	Iron	Steel ASTM A-36
27	Stuffing Box	Iron	Cast Iron ASTM A48
	Sleeve (Pack)	Iron	Hard Sln. Steel AISI 440C
36	Sleeve (Seal)	Iron	Bronze ASTM B62
	Sleeve (Seal)	Stainless	Stainless Steel AISI 316
40	Packing	Iron	Graphite/Teflon lube acrylic yarn
41	Lant. Ring	Iron	Teflon
		Stainless	Stainless Steel AISI 316
44	Gland	Iron	Cast Aluminum A356-T6
		Iron	Cadmium Plated Stl
44E	Clamp	Stainless	Stainless Steel AISI 18-8
	Stud (Optional)	Iron	Steel
45	Capscrew (Standard)	Stainless	Stainless Steel AISI 18-8
48	Shaft	Iron	Steel SAE 1045
49	Bearing	Iron	Steel
50	Bearing	Iron	Steel
51	Brg. Cap	Iron	Cast Iron ASTM A48
56	Frame	Iron	Cast Iron ASTM A48
+65	Elbow	Iron	Cast Iron ASTM A48

+Not Illustrated (Optional)
All iron pump construction is furnished unless specified.

MODEL 611A, 612A, 613A, AND 614A — Furnish and install as shown on the plans. Aurora Model . . . (Horizontal-611A) (Vertical-613A Flexible Coupled) (Vertical 612A Open Shaft) (Vertical 614A Close Coupled) type Non-Clog Centrifugal pump. The pump shall be capable of delivering a capacity of . . . GPM when operating against a total dynamic head of . . . feet. The pump shall also deliver a maximum of . . . GPM when operating against a head of . . . feet. The minimum shut-off head acceptable will be . . . feet. — The pump shall operate at a maximum speed of . . . RPM. A unit operating at a lesser rotative speed will be considered, but in no event will a pump operating at more than the maximum speed specified be acceptable. **PUMP CASING** — The pump casing shall be of the top centerline design and will be constructed of "APCO-LOY 33," and shall be of sufficient thickness to withstand stresses and strains at full operating pressures. Casings shall be subject to a hydrostatic pressure test of 125 lbs. A minimum size handhole 3" x 5" is to be provided in the casings for clean out purposes. The casing design shall allow front or rear impeller pullout. **BEARING HOUSING** — The bearing housing is to be of cast iron and shall be furnished with a set of regreaseable bearings for both radial and thrust loads. The bearings shall have an average life of 100,000 hours and shall be mounted in a machined, moisture and dust proof housing. The housing is to have register fit and then be bolted to the pump casing to insure permanent alignment. An extra deep (split) packing box simplifying packing replacement and shaft sleeve inspection is to be provided and must be so arranged with a lantern ring for either grease lubrication or tapped connections for water sealing from an outside source. A 3/4" drain opening must be provided to facilitate removal of lubricating liquid. **IMPELLER** — The impeller shall be of the enclosed type with wiper blades located on the back shroud to prevent accumulation of solids behind the impeller. The vanes shall be skewed to reduce noise. The impeller is to be of "APCO-LOY 33" and shall be capable of passing a minimum sphere size of . . . inches. The impeller shall be dynamically balanced

before assembly into the pump and shall be securely fastened to the shaft by means of a stainless steel key and impeller locknut. Axial adjustment of the impeller is to be external and a minimum clearance of . . . thousands should be maintained between the impeller and suction wearplate. **PUMP SHAFT** — The pump shaft shall be constructed of high grade carbon steel having a tapered impeller extension and accurately machined. The minimum diameter acceptable will be . . . inches. The pump shaft shall be protected from wear by a corrosion and wear resisting hardened stainless steel shaft sleeve having a 450 minimum brinell hardness. An "O" ring type gasket must be provided between the impeller hub and the shaft sleeve to prevent pumped liquid from corroding the shaft. **MODEL 611A** — The pump and motor shall be mounted on a common base (formed steel) (structural steel) with drip rim. Alignment shall be checked in accordance with the Standards of the Hydraulic Institute after installation and there shall be no strain transmitted to the pumps. **MODEL 612A** — Vertical open shaft pumps are to be driven through flexible shafting with . . . dia. tubing, and intermediate bearings. Shafting must be of sufficient size to transmit required horsepower and must be provided with a slip spline which will permit removal of the pump rotating assembly without removing any section of intermediate shafting, bearings, suction or discharge piping. **MODEL 613A** — Vertical flexible coupled pumps shall be furnished with a steel fab. motor bracket which is to be bolted to a separate pump adapter. **MODEL 610A-614A** — The motor bracket must be machined with a register fit to insure proper alignment of motor and pump shaft. **MODEL 612A, 613A AND 614A** — The pump shall be supported by a fab. steel pedestal base and shall be fab. with a square footing to prevent legs being broken during shipment. The pedestal shall have openings large enough to permit access to the suction line. A handhole of not less than 5" in diameter must be provided in the suction elbow. The pedestal must be of sufficient height so that the suction elbow will not touch the foundation upon which it stands.

The Engineering Specification has been condensed from a very comprehensive specification. Additional information is available from any Aurora Pump Sales Office. Aurora Pump reserves the right to make revisions to its products and their specifications, and to this bulletin and related information without notice.

— Your Authorized Local Distributor —

motralec
4 rue Lavoisier . ZA Lavoisier . 95223 HERBLAY CEDEX
Tel. : 01.39.97.65.10 / Fax. : 01.39.97.68.48
Demande de prix / e-mail : service-commercial@motralec.com
www.motralec.com

WEMM

ap AURORA
Pentair Pump Group

MARKETING & SALES:
800 AIRPORT ROAD • NORTH AURORA, ILLINOIS U.S.A. • 60542
PHONE: (630) 859-7000 U.S.A./CANADA FAX: (630) 859-7060
WORLDWIDE FAX: (630) 859-1226
WEB: www.aurorapump.com
EMAIL: aurora_info@pentairpump.com
AURORA MFG. PLANT:
800 AIRPORT ROAD • NORTH AURORA, ILLINOIS U.S.A. • 60542
SALES OFFICES IN ALL MAJOR CITIES AND COUNTRIES
Refer to "Pumps" in yellow pages of your phone directory for your local Distributor.