

ap

AURORA PUMP A member of PENTAIR PUMP GROUP

AURORA PUMP

BULLETIN 530A/Rev. I

530 SERIES

**SINGLE STAGE
SUMP
PUMPS—"NSB"**

CAPACITIES TO 1200 G.P.M.
HEADS TO 180 FEET
TEMPERATURES TO 180°F.

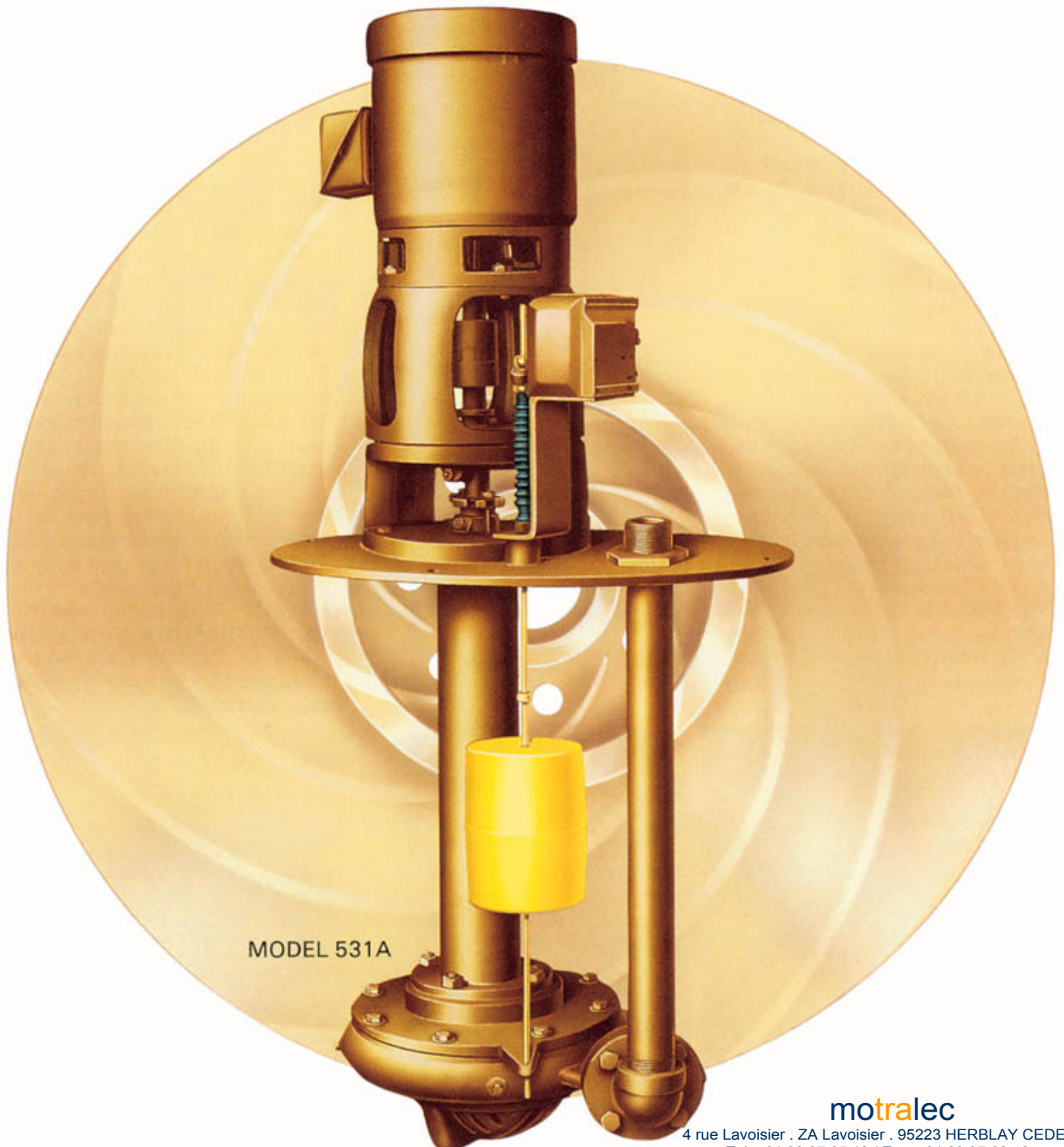

MODEL 531A

motralec

4 rue Lavoisier . ZA Lavoisier . 95223 HERBLAY CEDEX
Tel. : 01.39.97.65.10 / Fax. : 01.39.97.68.48
Demande de prix / e-mail : service-commercial@motralec.com
www.motralec.com

INTRODUCTION

AURORA 530 SERIES PUMPS

The vertical extended shaft single stage centrifugal pump occupies an important place within the pumping industry. It performs as no other pump can, the function of transferring liquid from below ground reservoirs or enclosed tanks. While the vertical pump is not necessarily expensive, its design is in many ways more critical than those of more common centrifugal pumping units. Attention must be paid to pump operating speeds, bearing arrangements, shaft design and construction. This bulletin illustrates, to the customer, how this pump will contribute to the solution of complex pumping applications.

1 MOTOR MOUNTING bracket that assures alignment of motor and pump shaft with tongue and groove machining. Motors are of standard "HP" manufacture.

2 THRUST BEARING is regreaseable and is protected from contamination by grease seals on both sides and a water slinger. The bearing is elevated 6" above the floor level for easy servicing and added protection from washdown, flooding, etc.

3 EXTERNAL IMPELLER ADJUSTMENT is accomplished with hex shaped adjusting nut.

4 STUFFING BOX is standard with packing, lantern ring and



a split gland for gastight construction. The lantern ring can also be used for packing lubrication from an external source.

5 STEEL OVAL BASEPLATE is standard and eliminates removing the complete cover plate.

6 ELEVATED FLOAT SWITCH ASSEMBLY is standard. Several enclosures are available. Refer to page 8 for additional details.

7 POSITIVE ALIGNMENT THROUGHOUT utilizes tongue and groove registered design.

8 PUMP SHAFT 1 $\frac{3}{16}$ " or 1 $\frac{7}{16}$ " in diameter is provided to minimize deflection & bearing wear.

9 BEARING ASSEMBLIES available in several arrangements and materials to suit difficult applications. Line bearings are provided on 6'-2" settings and deeper. One bearing is provided for each additional 5' of setting. All the standard bearings are grease lubricated.

10 LIQUID END includes a vacuum cast bronze impeller as standard. Impeller wearing rings or semi-open impellers are optional. Standard case wearing rings eliminate wear on the casing. A large area strainer keeps trash from clogging the impeller and pump casing.

11 DISCHARGE PIPE is secured to the baseplate and is threaded for convenient piping.

QUICK REFERENCE 530 SERIES FEATURE SELECTOR

STANDARD

- Bronze fitted construction
- Bronze pump bearings
- Bronze line bearings (6'-2" settings and deeper)
- Dynamically balanced vacuum cast enclosed impeller
- Elevated regreaseable thrust ball bearing
- Grease lubricated pump and line bearings
- Standard "HP" base motors
- Casing wearing ring(s)
- Carbon steel shaft
- Packing with lantern ring
- Oval baseplate
- 4" Vent — 34" baseplate and larger
- Float switch
- High density Polyethylene float and rod
- Elevated switch support
- External adjustment of impeller
- Pump setting increments of 6"
- Pump settings up to 15'-8"

OPTIONAL

- All iron, all bronze or stainless steel construction
- Various pump and line bearing types
- Semi-open impeller
- Drip oiler for line bearings
- Solenoid oiler for line bearings
- Impeller wearing rings
- Stainless steel shaft
- Round, square, or special baseplates
- 4" Vent — 28" baseplate and smaller (not available on oval plates)
- Various float switch enclosures
- High water alarm
- Float guard
- Pressurized support column
- Flushing lines to sleeve bearings
- Electric controllers
- Below surface discharge
- Pump settings over 15'-8"

PUMP FEATURES

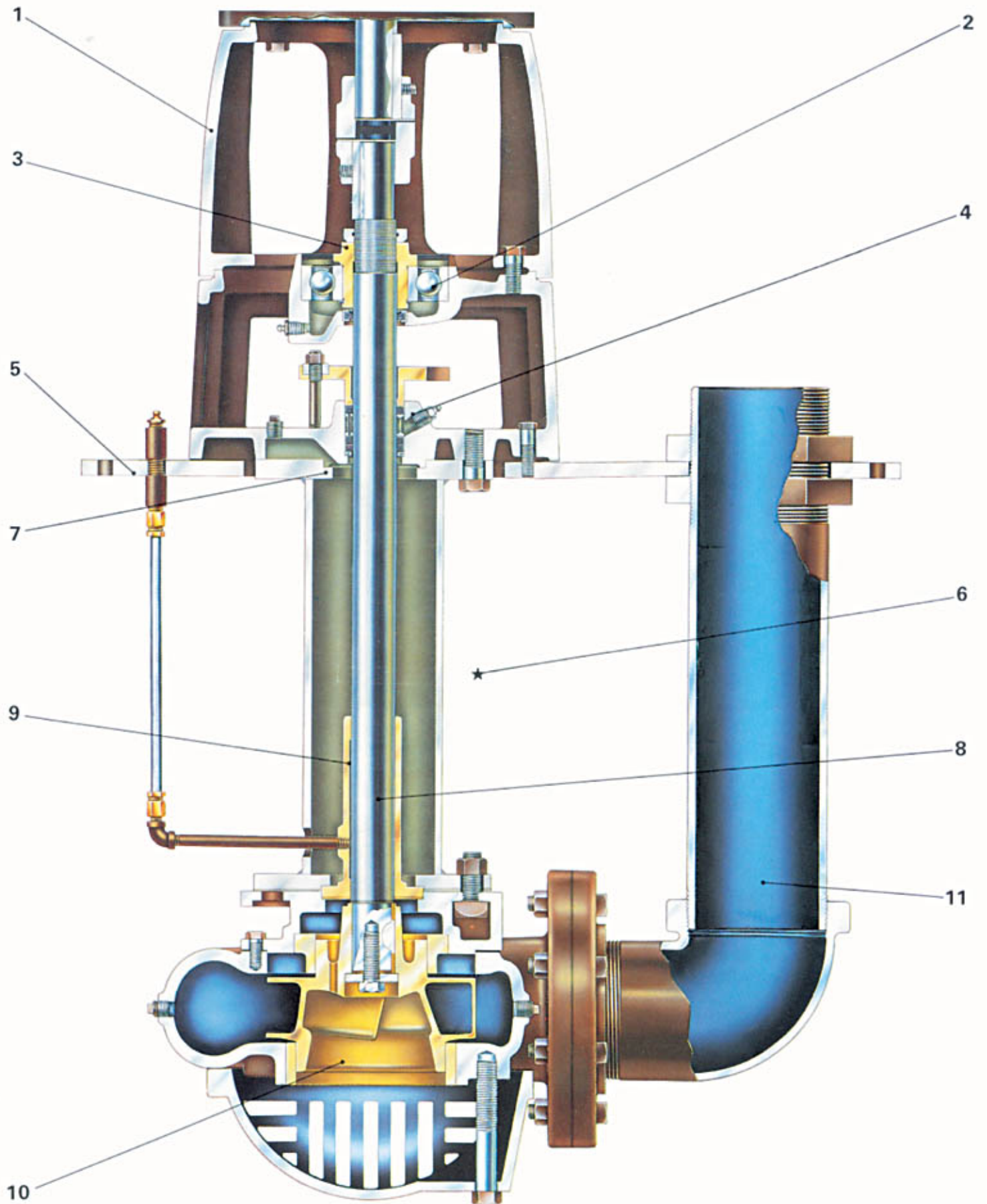

PUMP SELECTION AND RANGE CHARTS

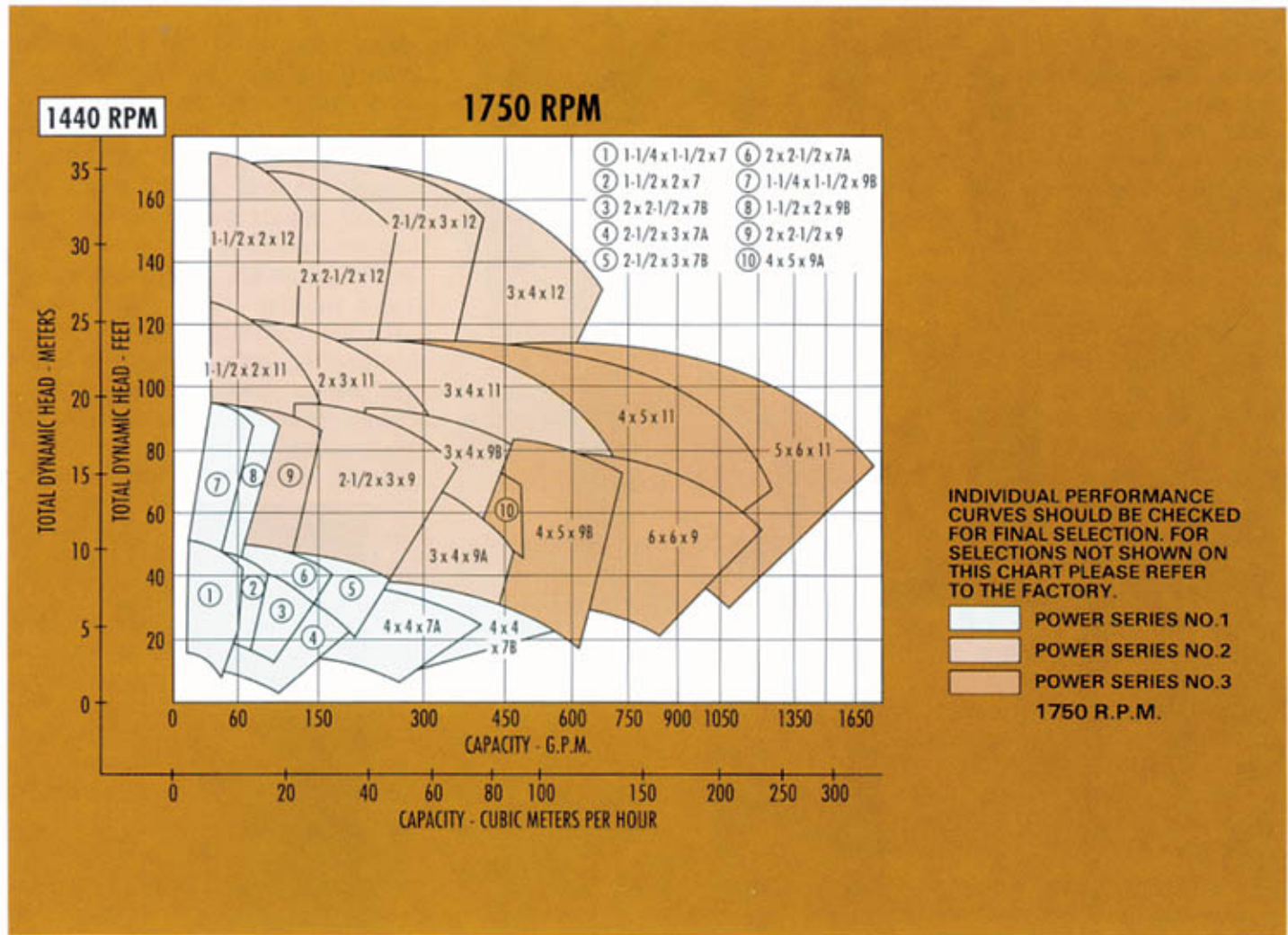

UNUSUAL SERVICE FLOW

Careful consideration should be given to potential additional flow from unusual or abnormal additions to the service flow. This would include such additional flow from such services as boiler drainage, air conditioning drainage water, etc. All of this service flow must be added to the projected pump capacity requirement.

DETERMINING PUMP DISCHARGE HEAD

The pump discharge head is calculated by determining the distance from the *lowest level of water in the basin* to the liquid discharge level. By using the discharge level as point of reference, a reasonable factor of safety is established, ac-

counting for the possibility of back pressure. To this you must add the friction loss in the discharge pipe line and fittings.

EXAMPLE:
 Distance from lowest level of water to discharge level 26 feet
 Friction of discharge pipe (150 G.P.M. 4" pipe 150' long) 2 feet
 Friction of pipe fittings (elbows, check valves, gate valves, Y-branch, etc.) 2 feet
 Total discharge head 30 feet

DETERMINING TANK OR BASIN SIZE

The size of the tank or basin should be carefully selected to prevent both short cycling of the pumping operation and excessive settling out of sediment. A drawn down ratio of 3 to 1 is recommended . . . this means that the basin area between the low liquid level and the high liquid level should accommodate 3 times the capacity of the

pump before the pumping cycle begins. A minimum distance of 1 foot between the lowest liquid level and the basin floor should be allowed. In addition, the distance between the maximum liquid level and the basin cover should be $\frac{1}{3}$ of the storage area between the high and low liquid levels, but not less than 2 feet. Where conditions limit the basin depth, the required capacity may be obtained by using a larger basin diameter. For fast calculation:

EXAMPLE:
 Total Pump capacity 150 G.P.M.
 Basin to hold 3 times pump capacity (3x150 Gal.) 450 Gal.
 From table below a 48" dia. basin will hold 95 Gal. per foot of depth.
 Therefore, basin depth is (450÷95) 4.74 ft.
 Add approx. $\frac{1}{3}$ to depth for storage between high level of liquid and basin cover or (minimum 2 ft.) 2.00 ft.
 Add approx. 1 ft. to depth for distance between lowest level of liquid and basin floor 1.00 ft.
 Total pit depth required 7.74 ft.
 Recommended pit depth (next standard 6" increment) 8 ft.

PUMPING SUBMERGENCE

Air may be entrained in the pumped liquid if the pump suction is located too close to the free liquid surface in the suction source. Pumping liquid with entrained air can cause a reduction of capacity, vibration, loss of efficiency and wasted power. Excessive wear of close running parts, bearing stresses and shaft damage are also subsequent effects. If the capacity in gallons per minute and the suction inlet size or area is known, the minimum height of the liquid above the suction inlet (submergence) can be determined. A properly designed suction inlet and sump can be accomplished with the help of the submergence chart.

EXAMPLES:

- (1) When the suction size is known, the minimum submergence required for 500 G.P.M. through a 4 inch suction is 2.2 feet.
- (2) When the suction area is known, the minimum submergence required for 500 G.P.M. through a 12.7 square inch suction is 2.2 feet.

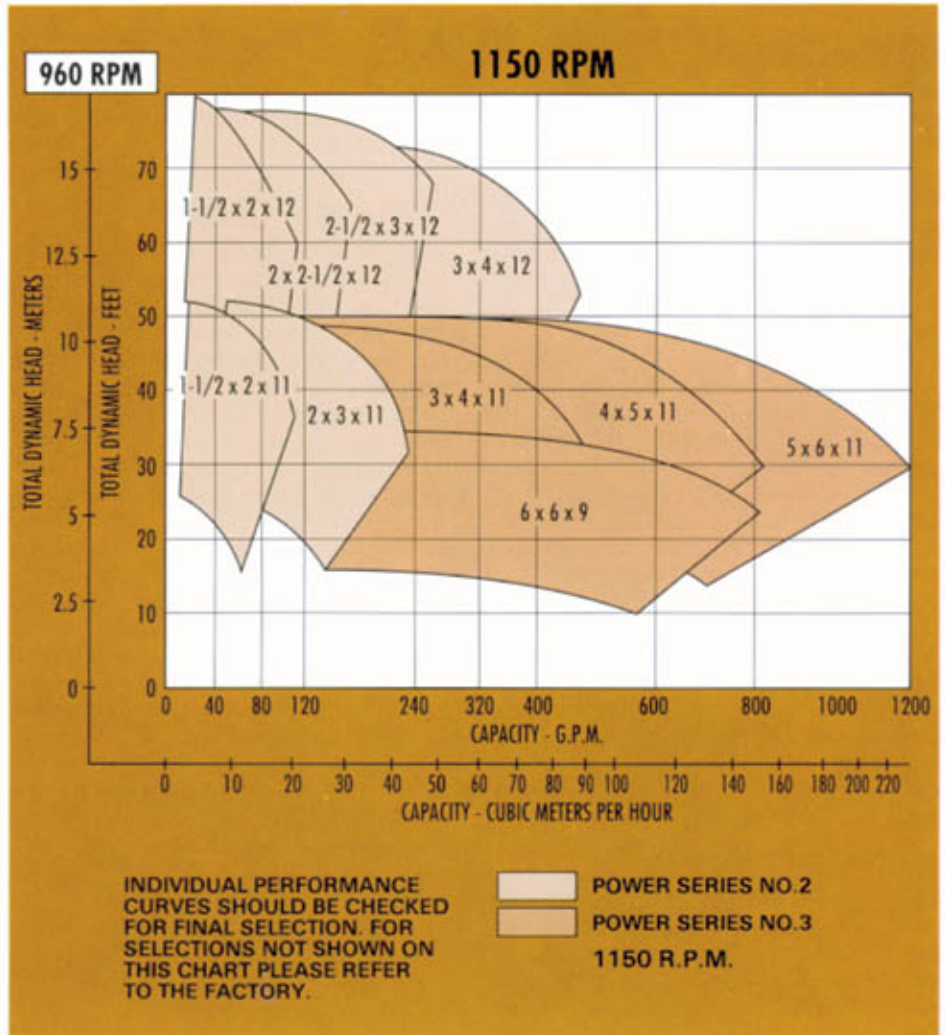

CALCULATING ROUND BASIN CAPACITIES

Per Foot of Depth

Pump Basin Dia. Inches	Simplex	Duplex
24	30	36
30	42	48
36	54	60
42	66	72
48	78	84
54	90	96
60	102	108
66	114	120
72	126	132

Capacity Per Foot In Gallons

TANKS ARE AVAILABLE IN DEPTHS OF 6" INCREMENTS.

CALCULATING SQUARE PIT CAPACITIES

To determine the size of a square or rectangular pit commonly used in concrete construction the same procedure as outlined in the example may be followed. To calculate the capacity of a pit other than a round one, use the following formula: Cubic content in cu. ft. X 7.48 = number of gallons.

1 FOOT MINIMUM — Refer to the chart for additional details.

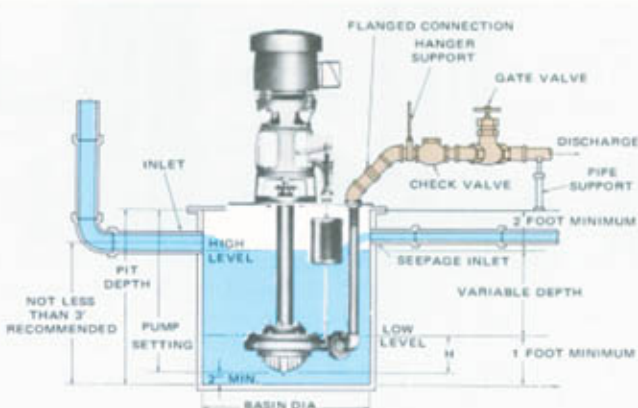

TYPICAL INSTALLATION
The piping layout shown here is of a conventional installation. Specific applications accommodating the individual service conditions, basin capacity, etc., will be reflected in change in diameter sizes of the basins and covers along with the basin depth.

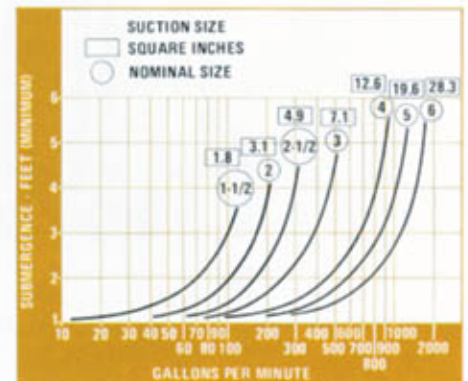

PUMP AND LINE BEARINGS

Two important parts in any sump pump construction are the pump and line bearings as they are immersed in the liquid. The line bearings frequently run wet or dry depending on the varying liquid level in the sump. A complete line of bearings for all types of service conditions is available. Line bearings are provided as standard on 6'-2" pump settings and for each additional 5' of setting thereafter.

STANDARD

All 530 Series pumps (except for 10 foot and deeper settings at 1750 R.P.M.) are furnished with a bronze sleeve type bearing unless an optional style is specified. The bearing is mounted directly above the impeller and receives lubrication from an external grease line. This bearing is also available in cast iron or ni-resist material. The majority of all vertical wet pit pump applications can be handled by this standard bearing. However, when pumping conditions are severe, abrasives are present in the liquid or the liquid temperature exceeds 140°F., one of the following optional bearings should be selected.

GRAPHITAR

The wearing surface of the graphitar bearing is made of non-metallic material. This optional bearing consists of a cast iron bearing housing and two graphitar bushings. Lubrication for this bearing is supplied by the liquid being pumped. The bearing may be used in conjunction with STANDARD line bearings or as alternate line shaft bearings. This bearing configuration is recommended for use on applications where the

temperature of the liquid exceeds 140°F. Stainless steel shafting is recommended for use with this bearing. *Do not, however, apply this option when the liquid being pumped contains abrasives, in such cases select one of the other bearing options.*

CUTLESS RUBBER

This bearing consists of a ferrous bearing housing, with a cutless rubber bushing inserted. All lubrication for this optional bearing is supplied by the liquid being pumped. This bearing may also be used in conjunction with STANDARD line bearings or as alternate line shaft bearings, *however, positive water lubrication, such as with pressurization, is necessary.* This option is recommended for applications where abrasives are held in suspension in the liquid pumped. The excellent abrasive resistant characteristics of rubber give this bearing several times the wear life than would the standard bearing. Stainless steel shafting is recommended when using this bearing. *Do not, however, apply this option when the liquid temperature exceeds 140°F., in such cases select one of the other bearing options.*

GLASS FILLED TEFLON*

The glass filled Teflon® bearing is similar in design to the graphitar pump bearing. The option consists of a one piece alloy bearing housing with multiple glass filled Teflon® bushings as the bearing surface. The self-lubricating, low friction and inert qualities of filled Teflon® make it ideal for handling hot liquids, chemicals and solvents which may attack standard bearing materials.

Stainless steel shafting is recommended. The bearing may be used in conjunction with STANDARD line bearings or as alternate line shaft bearings.

RELIEF

A RELIEF TYPE BEARING WILL BE SUPPLIED AS STANDARD FOR 10 FOOT AND DEEPER SETTINGS AT 1750 R.P.M. and is otherwise optionally available. The relief type bearing has three bushings inserted into the housing. When in operation the liquid being pumped goes through the lower portion of the bearing and is vented to the sump through the annular ring. This venting action permits only a small amount of liquid, with a fraction of the abrasive content, to enter into the top half of the bearing housing; as a result the upper portion wears at a much slower rate. The life expectancy of this optional design will be two to four times longer than the standard bearing. All three bushings can be constructed of different materials, therefore, opening a wide range of applications for this unique bearing. The STANDARD bearing is normally provided with this option on all line bearings, however, the GRAPHITAR or CUTLESS RUBBER options can also be provided. The liquid being pumped provides the required lubrication for the lower bushing. An external grease line lubricates the upper bushings when bronze or iron are provided. When other bushing materials are specified the pumped liquid provides the lubrication. Relief type bearings are recommended for your most demanding pump system applications.

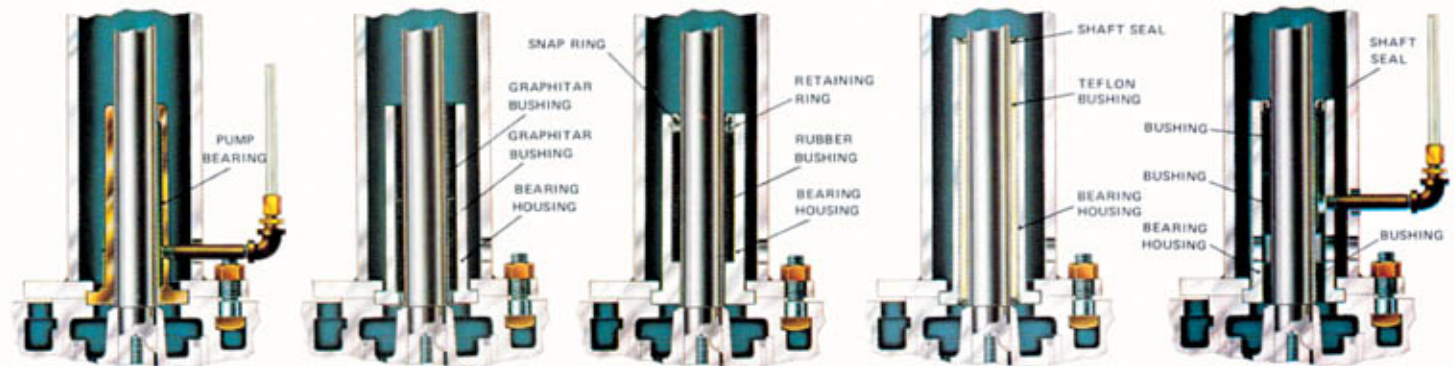

STANDARD

GRAPHITAR

CUTLESS RUBBER

FILLED TEFLON*

RELIEF

*Dupont registered trademark.

1. GREASE FITTINGS — STANDARD

Individual forced feed grease lubrication lines are provided to each Standard, Throttle or Relief type pump and line bearing. Individual grease lines to each bearing are recommended for installations where the pumping conditions are quite severe. By providing each bearing with a constant supply of grease the expense and necessity for replacing bearings are held to a minimum. Following are several examples of installations where grease lines are recommended: 1) high temperature liquids are present; 2) the liquid contains abrasives; 3) a liquid with non-lubricating qualities is being pumped. Grease is forced through zerk fittings conveniently located on the baseplate and then through flexible $\frac{3}{8}$ " O.D. Nylon tubing directly into each bearing. The oversize tubing I.D. also minimizes the pressure required to force the grease to the bearings.

2. SOLENOID OIL LUBRICATOR

A solenoid valve operated oiler mounted on the lower head with individual feeders to substitute for the zerk fittings can also be provided. Oil is released by gravity from a reservoir by a normally closed electric solenoid valve to single or multiple sight feed valves for individual flow to each bearing. The sight feed valves can be separately adjusted. Oilers can be provided with capacities of one pint or one quart.

3. DRIP OILER

In lieu of lubrication lines to line bearings a drip oiler is available and mounts in a tap in the lower head.

4. SOLENOID WATER LUBRICATOR

A solenoid valve operated clear water valve can also be substituted for the zerk fittings. This option automatically provides water lubrication to pump and line shaft bearings while the pump is running and is especially useful when pressurized support column is provided. This option is also recommended for use with cutless rubber bearings described on pg. 6.

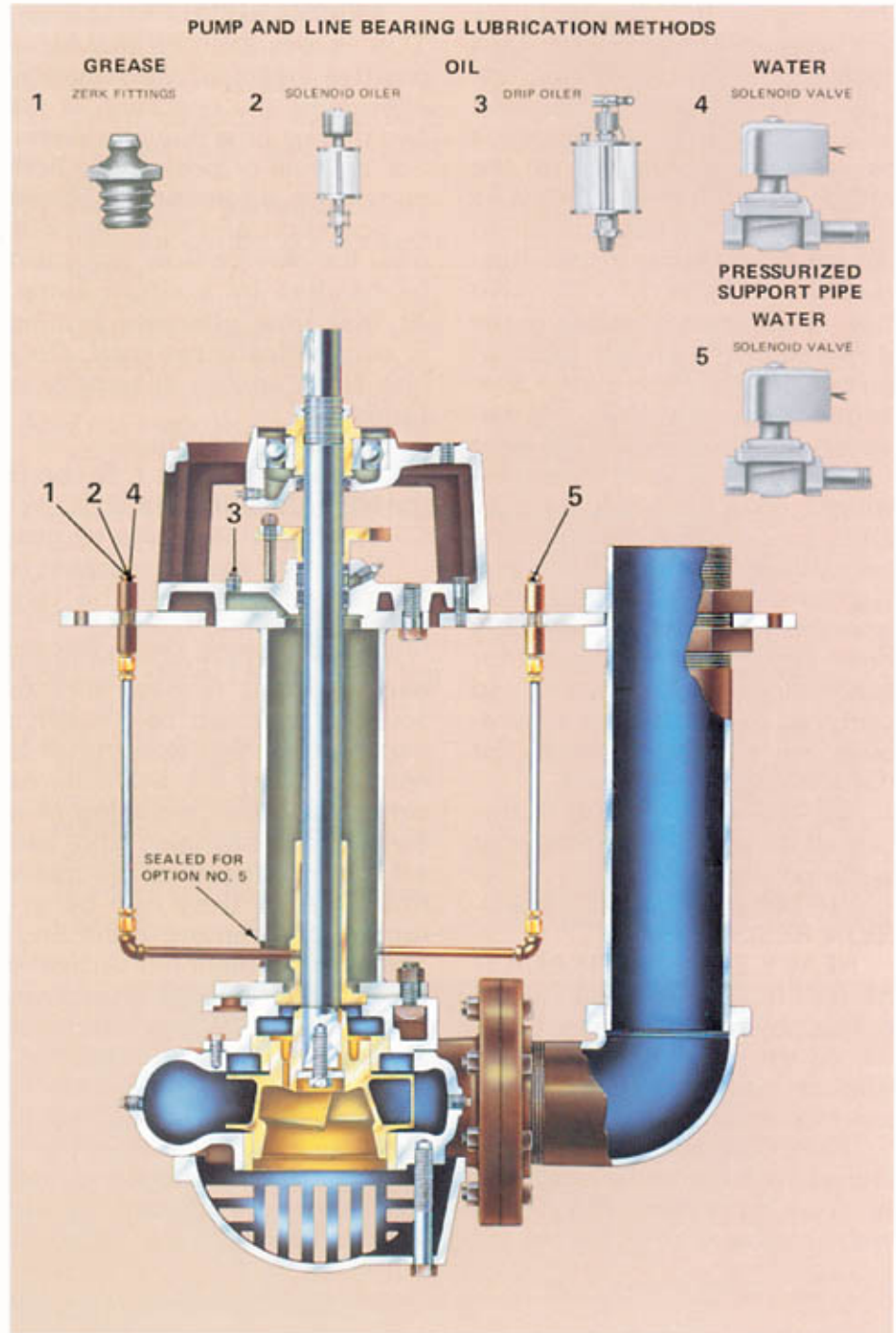

5. PRESSURIZED SUPPORT COLUMN

Pressurizing the support column with water, is a preferred way of handling harmful matter entrained in the pumped solution. The column is pressurized by forcing water, under a higher pressure than the pump discharge, through the oiler hole in the lower head into all sections of the support column. On long pump settings an auxiliary pressure line is

connected to the section of support pipe above the pump bearing to maintain pressure at the bottom of the column. The continuous action of water flushing through the bearing minimizes the possibility of damaging liquids backing up into the bearing housing. This system should be utilized when handling; 1) highly corrosive liquids; 2) high temperature liquids; 3) liquids with heavy concentrations of abrasive materials; or 4) non-lubricating liquids. See Bulletin 680, Water Seal Units.

FLOAT CONTROLS AND CONTROLLERS

The float switch assembly for the simplex unit consists of the float, float rod, rod guides, adjusting stops, gastight pedestal and float switch. This unit serves as a pilot device for the motor magnetic starter. It is mounted on the basin cover in the position shown in the illustration on page 11. The two float stops are adjustable to the desired high and low level pumping levels. The plastic float slides along the float rod between the float stops. The float rod is balanced with a counterweight on the switch arm for quick response. A flexible rubber bellows is supplied for gastight service. On the Duplex unit the float switch assembly described above is provided for each pump. The standard and optional float switch assemblies are the same except for the switches themselves.

STANDARD DUTY is designed for operation on basin or sump pit applications.

WATERTIGHT AND EXPLOSION RESISTING.

HEAVY DUTY WITH BUILT-IN OVERLOAD PROTECTION is reset by pressing a reset button on the outside of the case. Application is restricted according to horsepower limitations.

EXPLOSION-PROOF is designed for hazardous locations. All working parts of the switch are completely immersed in oil.

MECHANICAL ALTERNATOR is designed to provide a positive means of mechanically alternating the operation of the two pumps on a duplex system. For unusual or peak loads both pumps are automatically placed in operation and will continue until the service flow can again be handled by a single pump. At that time alternate cycling is automatically resumed. Only one float switch assembly is furnished.

A. NEMA 1 Enclosure.

B. Gastight — Class I, Group D Hazardous locations.

C. Watertight — Same as gastight unit except a gasket is placed between the two halves of the housing.

HIGH WATER ALARM is for use where it is desirable to sound a warning bell when a dangerously high water level is reached. They are available as complete units consisting of a switch, transformer, and bell all mounted within the same housing, or they can be arranged for remote mounting. The alarm is mounted vertically on a 1" pipe through the cover.

FLOAT GUARD enclosure, of either sheet or mesh steel, supported from the baseplate in shorter settings or secured to the support pipe in deeper settings, encases the float and float rod to prevent damage by objects entrained in the liquid.

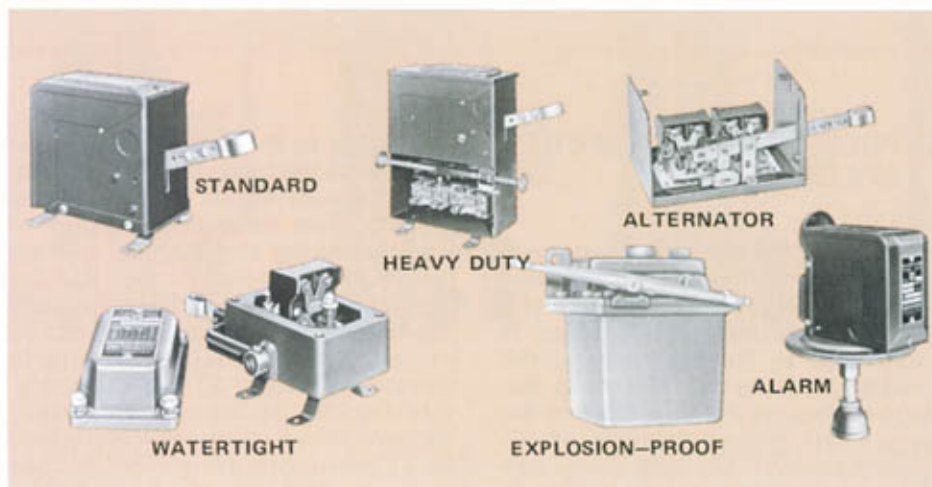
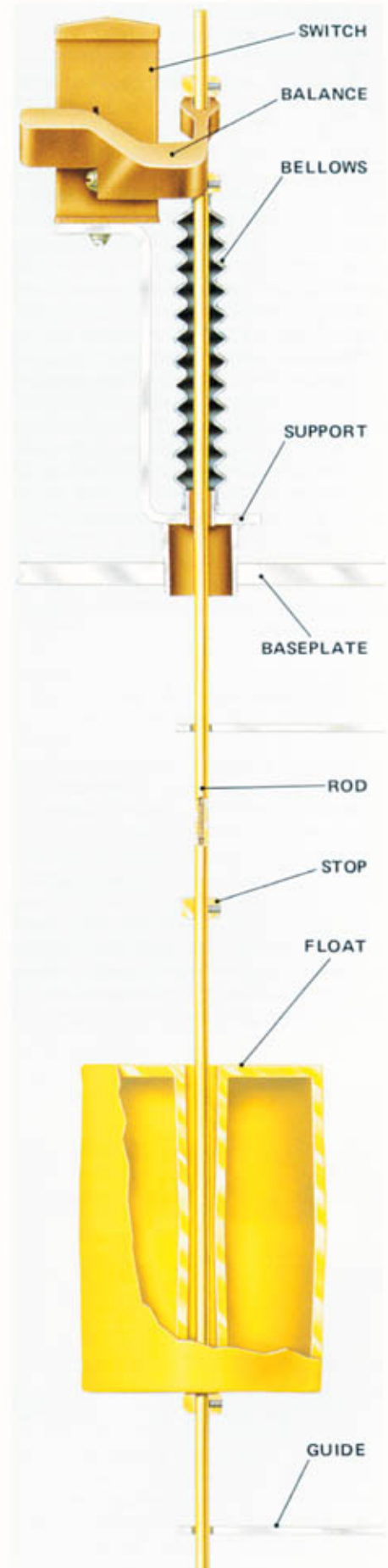

DUPLEX PUMP CONTROLLERS AND OPTIONAL EQUIPMENT

MODEL (LDS) consists of two magnetic starters, an electric alternator, with the components prewired and enclosed in a common panel.

MODEL (FD or NFD) These duplex controllers include two magnetic starters, an electric alternator, fusible or non-fusible disconnect switches, with the components prewired and enclosed in a common panel. Disconnect switch handles protrude through the cover door.

MODEL (CB) This prewired panel includes two magnetic starters, an electric alternator, and magnetic trip circuit breakers. The handles of the circuit breaker protrude through the cover door.

THE ELECTRIC ALTERNATOR in these duplex pump controllers alternate the pumping cycle from one pump to the other.

OPTIONAL EQUIPMENT AVAILABLE WITH CONTROL PANEL

- 1) Third overload relay with thermal unit, one for each motor.
- 2) (H-O-A) "Hand-Off-Auto" selector switch, one for each motor.
- 3) Control circuit transformer with 550, 440, or 220 Volt primary and 110 Volt secondary, one for each motor.
- 4) Pilot light in cover, one for each motor.

FLOOR MOUNTING STAND. AVAILABLE FOR ALL MODELS

When ordering, please state model and give horsepower, voltage, phase, cycle and full load current rating of motors. Panels are available in:

- NEMA Type 1 General Purpose Enclosure.
- NEMA Type 4 Watertight Enclosure.
- NEMA Type 12 Dust-tight Enclosure.

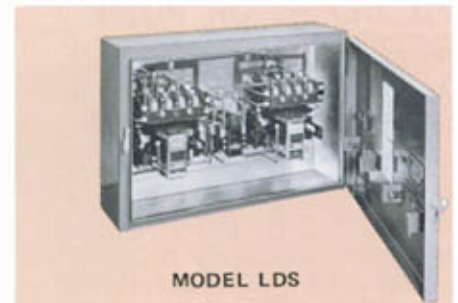

MODEL LDS



MODEL FD OR NFD



MODEL CB

OPTIONAL EQUIPMENT

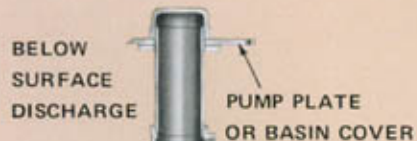
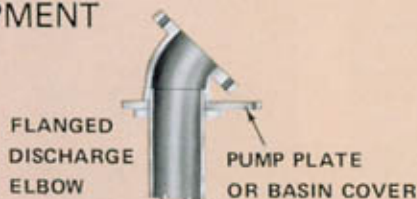

IMPELLER WEARING RINGS



SEMI-OPEN IMPELLER

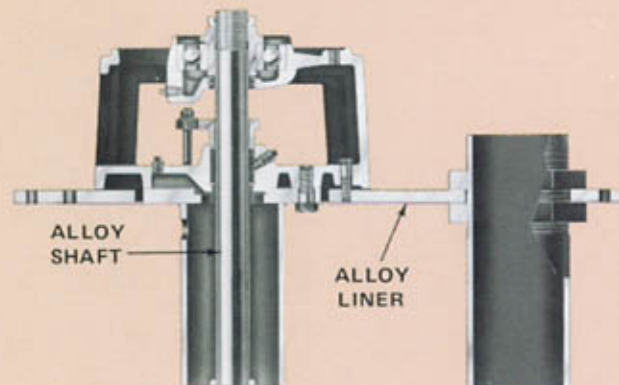

ENGINEERING DETAILS

PIT DEPTH OR PUMP SETTING

Aurora wet pit pumps are available in lengths shown in the chart. For pit depths or pump settings other than shown, refer to the factory. A pump may be specified either by pit depth or pump setting. These lengths are measured from either: the underside of the basin cover to the bottom of the strainer; or from the top of the sump basin to the bottom of the basin as illustrated. The distance between the pit depth and pump setting will vary from 4" to 6" depending upon the pump size and whether a cast iron or steel basin cover is used.

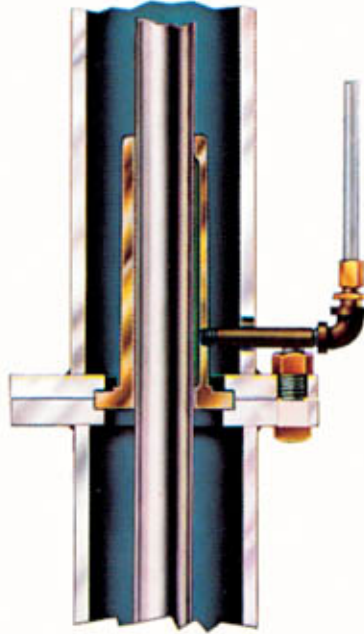

DESIGN DETAILS

AREA	DESCRIPTION	POWER SERIES	
		1	2 & 3
PUMP SHAFT	ROTATION — FROM DRIVER END	CW	CW
	DIAMETER AT IMPELLER	7/8	1 1/4
	DIAMETER BETWEEN COUPLING & IMPELLER	1 3/8	1 7/8
	DIAMETER AT COUPLING END	1	1 1/4
	COUPLING KEY — SQUARE	1/4	1/4
BEARING	BEARING (BALL) — HEAD	311	311
	BEARING (SLEEVE) — PUMP	6" LG.	6" LG.

PIT DEPTH OR PUMP SETTING

LENGTH IN FT.		LENGTH IN FT.		LENGTH IN FT.	
PIT DEPTH	PUMP SETTING	PIT DEPTH	PUMP SETTING	PIT DEPTH	PUMP SETTING
2'	1'-8"	7'	6'-8"	12'	11'-8"
2'-6"	2'-2"	7'-6"	7'-2"	12'-6"	12'-2"
3'	2'-8"	8'	7'-8"	13'	12'-8"
3'-6"	3'-2"	8'-6"	8'-2"	13'-6"	13'-2"
4'	3'-8"	9'	8'-8"	14'	13'-8"
4'-6"	4'-2"	9'-6"	9'-2"	14'-6"	14'-2"
5'	4'-8"	10'	9'-8"	15'	14'-8"
5'-6"	5'-2"	10'-6"	10'-2"	15'-6"	15'-2"
6'	5'-8"	11'	10'-8"	16'	15'-8"
6'-6"	6'-2"	11'-6"	11'-2"	REFER TO FACTORY	

INTERMEDIATE LINE SHAFT BEARINGS

PIT DEPTHS	PUMP SETTING	NO. OF LINE SHAFT BRG.
6'-6"	6'-2"	1
11'-6"	11'-2"	2
16'-6"	16'-2"	3

MAXIMUM LIMITATIONS

BASED ON STD. MAT'L. AND PUMPING CLEAR WATER		
SPEED — RPM		1750
MINIMUM HORSEPOWER	1750 RPM 1150 RPM	1 3/4
TEMPERATURE — °F		180
HYDROSTATIC TEST PRESSURE — PSI		120
CASE WORKING PRESSURE — PSI		80
BASIN PRESSURE — PSI		2
BASIN COVER SIZE	W/O OVAL OR MANHOLE	28
	W OR W/O OVAL OR MANHOLE	78

MATERIAL OF CONSTRUCTION

PUMP PART	BRONZE FITTED	ALL BRONZE*	ALL IRON	STAINLESS STEEL*
BASEPLATE	STEEL WRT	STEEL WRT	STEEL WRT	STEEL WRT
BEARING (Pump and Line)	BRONZE ASTM B62-63	BRONZE ASTM B62-63	CAST IRON ASTM A48-64	GRAPHITAR
BEARING COLLAR	BRONZE ASTM B62-63	BRONZE ASTM B62-63	BRONZE ASTM B62-63	BRONZE ASTM B62-63
BEARING COVER	CAST IRON ASTM A48-64	BRONZE ASTM B62-4A	CAST IRON ASTM A48-64	STAINLESS STEEL AISI 316
CASING	CAST IRON ASTM A48-64	BRONZE ASTM B62-4A	CAST IRON ASTM A48-64	STAINLESS STEEL AISI 316
DISCHARGE PIPE	STEEL WRT-SCHD 40	BRASS ASTM B135	STEEL WRT-SCHD 40	STAINLESS STEEL AISI 316
HEAD-LOWER	CAST IRON ASTM A48-64	CAST IRON ASTM A48-64	CAST IRON ASTM A48-64	CAST IRON ASTM A48-64
HEAD-UPPER	CAST IRON ASTM A48-64	CAST IRON ASTM A48-64	CAST IRON ASTM A48-64	CAST IRON ASTM A48-64
IMPELLER	BRONZE ASTM B62-63	BRONZE ASTM B62-4A	CAST IRON ASTM A48-64	STAINLESS STEEL AISI 316
PACKING	INTERWOVEN GRAPHITE/TEFLON LUBRICATED ACRYLIC YARN PACKING. DIE MOLDED, DIAGONALLY CUT			
SHAFT	STEEL AISI C1045	STAINLESS STEEL AISI 316	STEEL AISI C1045	STAINLESS STEEL AISI 316
STRAINER	CAST IRON ASTM A48-64	BRONZE ASTM B62-4A	CAST IRON ASTM A48-64	STAINLESS STEEL AISI 316
SUPPORT PIPE	STEEL WRT-SCHD 40	BRASS ASTM B135	STEEL WRT-SCHD 40	STAINLESS STEEL AISI 316
WEARING RING(S)	BRONZE ASTM B62-63	BRONZE ASTM B144-3B	CAST IRON ASTM A48-64	STAINLESS STEEL AISI 316

POWER SERIES

PUMP SIZE	BASIC POWER SERIES	SHAFT DIA.	SUPPORT PIPE SIZE	
			* UP TO 10' DEEP SETTING	** OVER 10' DEEP SETTING
1 1/4 x 1 1/2 x 7	1	1 1/4	2 1/2	3
1 1/4 x 1 1/2 x 9B	1	1 1/4	2 1/2	3
1 1/2 x 2 x 7	1	1 1/4	2 1/2	3
1 1/2 x 2 x 9	1	1 1/4	2 1/2	3
1 1/2 x 2 x 12	2	1 1/4	2 1/2	3
1 1/2 x 2 x 11	2	1 1/4	2 1/2	3
2 x 2 1/2 x 7	1	1 1/4	2 1/2	3
2 x 2 1/2 x 9	2	1 1/4	2 1/2	3
2 x 3 x 11	2	1 1/4	2 1/2	3
2 x 2 1/2 x 12	2	1 1/4	2 1/2	3
2 1/2 x 3 x 7	1	1 1/4	2 1/2	3
2 1/2 x 3 x 9	2	1 1/4	2 1/2	3
2 1/2 x 3 x 12	2	1 1/4	2 1/2	3
3 x 4 x 9	2	1 1/4	2 1/2	3
3 x 4 x 11	2	1 1/4	2 1/2	3
3 x 4 x 12	2	1 1/4	2 1/2	3
4 x 4 x 7	1	1 1/4	2 1/2	3
4 x 5 x 9A	3	1 1/4	4	4
4 x 5 x 9B	3	1 1/4	4	4
4 x 5 x 11	3	1 1/4	4	4
5 x 6 x 11	3	1 1/4	4	4
6 x 6 x 9	3	1 1/4	4	4

*STD. PUMP OR LINE BRGS. **SPEC. PUMP OR LINE BRGS.

PUMP DIMENSIONS

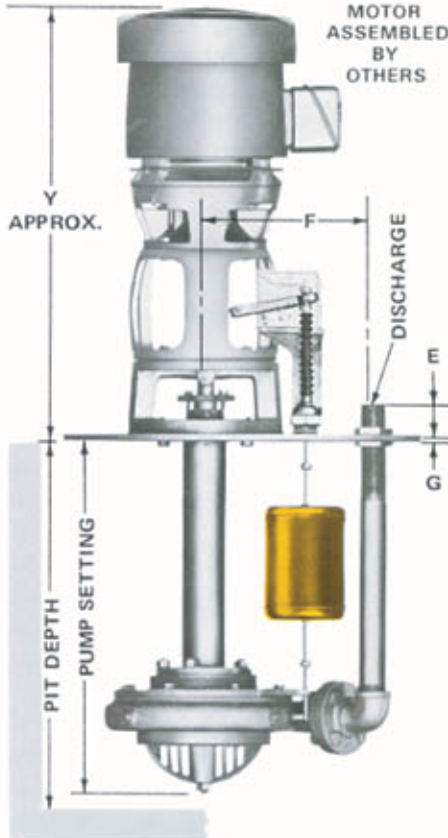
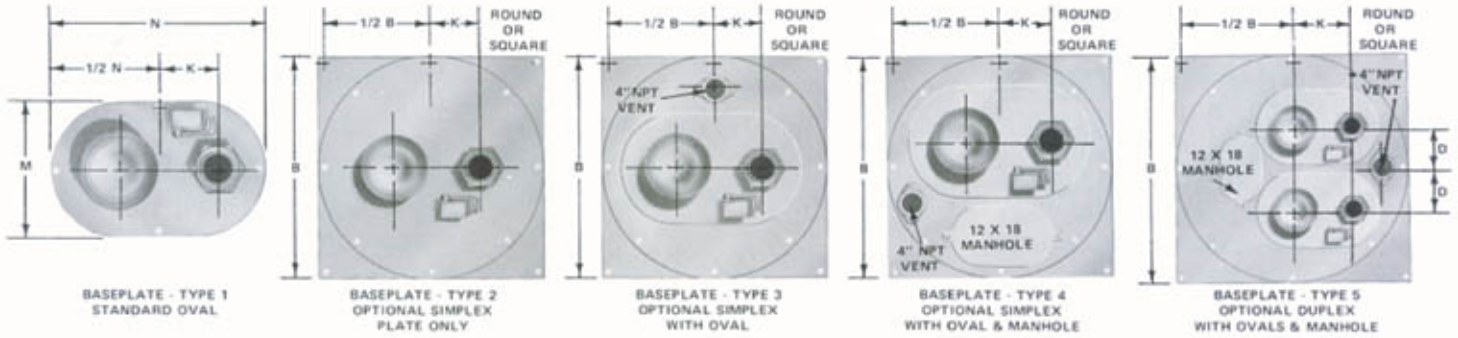

BASEPLATE — OVAL — STEEL

NO.	TYPE	G	M	N	WGT
1	20 x 24	1/4	20	24	36
2	22 x 28	1/2	22	28	63
3	26 x 36	1/2	26	36	102

BASEPLATES — ROUND OR SQUARE — STEEL

B	TYPE 2		TYPE 4		TYPE 5	
	OVAL NO.	WGT.	OVAL NO.	WGT.	OVAL NO.	WGT.
24	N.A.	1/4	41	54		
26	N.A.	1/4	58	76		
34	1	1/4	89	115		
40	2	1/4	126	163	1	1/4
46	2	1/2	225	289	2	1/2
53	2	1/2	392	387	2	3/4
60	2	3/4	487	623	2	3/4
66	2	3/4	592	755	2	3/4
76	2	1	832	1060	2	1

MOTOR

FRAME	HORSEPOWER		MOTOR WGT (LBS)	UPPER HEAD WGT (LBS)	Y APPROX
	1750	1150			
143 HP	1	3/4	40	21	25
145 HP	1 1/2	2	45	21	26
182 HP	3	1 1/2	72	21	27
184 HP	5	2	80	21	28
213 HP	7 1/2	3	130	21	30
215 HP	10	5	145	21	32
254 HP	15	7 1/2	220	21	34
256 HP	20	10	240	21	36
284 HPH	25	15	330	42	39
286 HPH	30	—	370	42	40
324 HP	40	—	475	42	41
326 HP	50	—	525	42	43
364 HP	60	—	630	42	48
365 HP	75	—	690	42	48

- NOTES:**
1. Dimensions and weights are approximate.
 2. All dimensions in inches and may vary $\pm 1/8"$.
 3. Frame sizes, "Y" dimension and motor weight are for open drip-proof motors only.
 4. Conduit box is shown in approximate position.

- Dimensions are not specified as they vary with each motor manufacturer.
5. Add pump(s), base(s), upper head(s) and motor weight(s) for unit weight.
 6. Not for construction purposes unless certified.

PUMP SIZE				PUMP WL. LBS.			MINIMUM BASEPLATE SIZE										
DISCH.	SUCTION	CASE BORE	5'-8" SETTING	FOR EA ADD 1' SETTING	D	E	F	TYPE 1		TYPE 2		TYPE 3		TYPE 4		TYPE 5	
								SIZE	K	SIZE	K	SIZE	K	SIZE	K	SIZE	K
1 1/4	1 1/2	7	202	20	10 1/2	3 1/2	8 1/4	20 x 24	5 1/4	24	5 1/4	34	5 1/4	40	5 1/4	46	8 1/4
1 1/4	1 1/2	9B	222	20	10 1/2	3 1/2	9 1/4	20 x 24	7 1/4	24	7 1/4	34	7 1/4	40	7 1/4	46	10 1/4
1 1/2	2	7	217	20	10 1/2	3 3/4	8 1/4	20 x 24	6	24	6	34	6	40	6	46	9
1 1/2	2	9	241	20	10 1/2	3 3/4	10 1/4	20 x 24	7 3/4	24	7 3/4	34	7 3/4	40	7 3/4	46	10 3/4
1 1/2	2	11	247	20	10 1/2	3 3/4	10 1/4	22 x 28	7 3/4	26	7 3/4	34	7 3/4	40	7 3/4	46	10 3/4
1 1/2	2	12	252	25	11 1/2	3 3/4	12 1/4	22 x 28	9 1/4	26	9 1/4	36	9 1/4	42	9 1/4	53	11 1/4
2	2 1/2	7	234	20	10 1/2	4 1/4	10 3/4	20 x 24	7 1/4	26	7 1/4	34	7 1/4	40	7 1/4	46	10 3/4
2	2 1/2	9	245	25	11 1/2	4 1/2	12	22 x 28	9	26	9 1/2	36	9	42	9	53	11 1/2
2	3	11	282	25	11 1/2	4 1/2	12	22 x 28	7 3/4	30	7 3/4	36	7 3/4	42	7 3/4	53	10 3/4
2	2 1/2	12	296	25	11 1/2	3 3/4	13 3/4	22 x 28	10 1/4	30	11 1/4	36	10 1/4	42	10 1/4	53	13 3/4
2 1/2	3	7	220	20	11 1/2	4 3/4	11 1/4	22 x 28	8 1/4	26	8 1/4	36	8 1/4	42	8 1/4	53	10 3/4
2 1/2	3	9	267	25	11 1/2	4 3/4	12 3/4	22 x 28	9 1/4	28	10 1/4	36	9 1/4	42	9 1/4	53	12 3/4
3	4	11	292	25	11 1/2	4 3/4	12 3/4	22 x 28	10	10	10	36	10	42	10	53	12 3/4
2 1/2	3	12	314	25	11 1/2	3 3/4	14 1/2	22 x 28	9	32	12	36	9	42	9	53	11 1/2
3	4	9	295	25	11 1/2	4 3/4	13 3/4	22 x 28	8 1/4	32	11 1/4	36	8 1/4	42	8 1/4	53	10 3/4
3	4	12	296	25	11 1/2	4 3/4	15 1/4	22 x 28	9 1/4	32	11 1/4	36	9 1/4	42	9 1/4	53	12 3/4
4	4	7	304	20	11 1/2	4 3/4	13 3/4	22 x 28	8 1/4	36	8 1/4	42	8 1/4	42	8 1/4	53	10 3/4
4	5	9A	340	30	11 1/2	4 3/4	14 3/4	22 x 28	8 1/4	36	8 1/4	42	8 1/4	42	8 1/4	53	11 3/4
4	5	9B	340	30	11 1/2	4 3/4	15 1/4	22 x 28	9 1/4	36	9 1/4	42	9 1/4	42	9 1/4	53	12 3/4
4	5	11	390	30	11 1/2	4 3/4	15 1/4	26 x 36	11 1/4	46	11 1/4	46	11 1/4	46	11 1/4	64	11 3/4
5	6	11	430	30	11 1/2	5 1/4	14 1/4	26 x 36	10 1/2	46	10 1/2	46	10 1/2	46	10 1/2	64	10 1/2
6	6	9	442	30	11 1/2	5 1/4	14 1/4	22 x 28	8 1/4	36	8 1/4	42	8 1/4	42	8 1/4	53	11 1/4

The contractor shall furnish (and install as shown on the plans) Aurora Model (531A Simplex) (532A Duplex) centrifugal sump pumps size x x of (bronze fitted) (all bronze) (all iron) (stainless steel) construction. Each pump shall have a capacity of G.P.M. at ft. total head, with a temperature of °F., specific gravity.

The units shall be designed for a sump depth of feet and shall be furnished with an (above the floor discharge terminating at the baseplate with a threaded connection) (below the floor discharge terminating with a threaded pipe connection).

A steel baseplate (oval); (round) (square) — (Simplex) (Simplex with oval) (Simplex with oval and manhole) (Duplex with ovals and manhole) will be provided.

The pump casing and bearing cover shall be of cast iron. The casing is to be provided with wearing rings held securely in place by means of a

press fit. A strainer of sufficient size shall be bolted to the pump casing.

The impeller is of the (enclosed) (semi-open) standard type and shall be constructed of (vacuum cast bronze) (cast). The impeller is to be dynamically balanced and keyed to the pump shaft.

The column pipe must be with a minimum diameter of” having machined tongue and grooved joints to insure shaft alignment. A pump bearing will be located directly above the impeller and shall be of the (bronze sleeve) (graphitar) (cutless rubber) (filled Teflon*) (relief) type.

Line bearings must be provided with a setting of 6’-2” and one bearing or each additional 5’ of setting thereafter. All standard sleeves, throttle or relief pump and line bearings must be (grease) (oil) (water) lubricated through separate Nylon tube lubrication lines terminating at the baseplate.

The motor pedestal is to be of cast iron, two piece construc-

tion, fitted with a sealed thrust ball bearing located 6” above the baseplate. The ball bearing collar will be arranged to allow external axial adjustment of the shaft and impeller. Grease seals shall be provided to retain grease and to prevent contamination of the vertically mounted ball bearing. A grease fitting will be provided to allow regreasing of the bearing. A packed stuffing box with lantern ring and split gland provides for gastight construction. The pump shall be controlled by an enclosed (heavy duty) (water tight and explosion resisting) heavy duty with built in overload protection) (explosion proof) type float operated switch 6” above the baseplate with high density Polyethylene float and float rod. A flexible bellows will provide gastight construction.

An automatic alternator shall be furnished on duplex pumps to allow the pumps to alternate on each successive cycle of operation.

The pumps are to be driven by and flexible coupled to a standard “HP,” . . . H.P., . . . volt, . . . phase, . . . Hertz, . . . R.P.M., . . . vertical electrical motor.

Many thousands of Aurora pumps serve building facilities, municipalities, utilities, industries, institutions, and maritime, government, and armed services throughout the world . . . the result of dedication to creative pump engineering since 1919, when the firm was founded as the Aurora Pump

and Manufacturing Company. New product development, product refinement, and expansion of sizes to accommodate broader ranges of application have been continuous and aggressive since that date. The resulting company growth has elevated Aurora to its present prominent industry position.



NOTE: Aurora Pump reserves the right to make revisions to its products and their specifications, and to this bulletin and related information without notice.

— Your Authorized Local Distributor —

motralec

4 rue Lavoisier . ZA Lavoisier . 95223 HERBLAY CEDEX
Tel. : 01.39.97.65.10 / Fax. : 01.39.97.68.48
Demande de prix / e-mail : service-commercial@motralec.com
www.motralec.com

WEMA



ap AURORA®
Pentair Pump Group

MARKETING & SALES:
800 AIRPORT ROAD • NORTH AURORA, ILLINOIS U.S.A. • 60542
PHONE: (630) 859-7000 U.S.A./CANADA FAX: (630) 859-7060
WORLDWIDE FAX: (630) 859-1226

WEB: www.aurorapump.com
EMAIL: aurora_info@pentairpump.com

AURORA MFG. PLANT:
800 AIRPORT ROAD • NORTH AURORA, ILLINOIS U.S.A. • 60542

SALES OFFICES IN ALL MAJOR CITIES AND COUNTRIES
Refer to “Pumps” in yellow pages of your phone directory for your local Distributor.