



**AURORA**<sup>®</sup>  
Pentair

# 3500 Series

## Model 3550 ASME/ANSI B73.1M

### Industrial Process Pumps

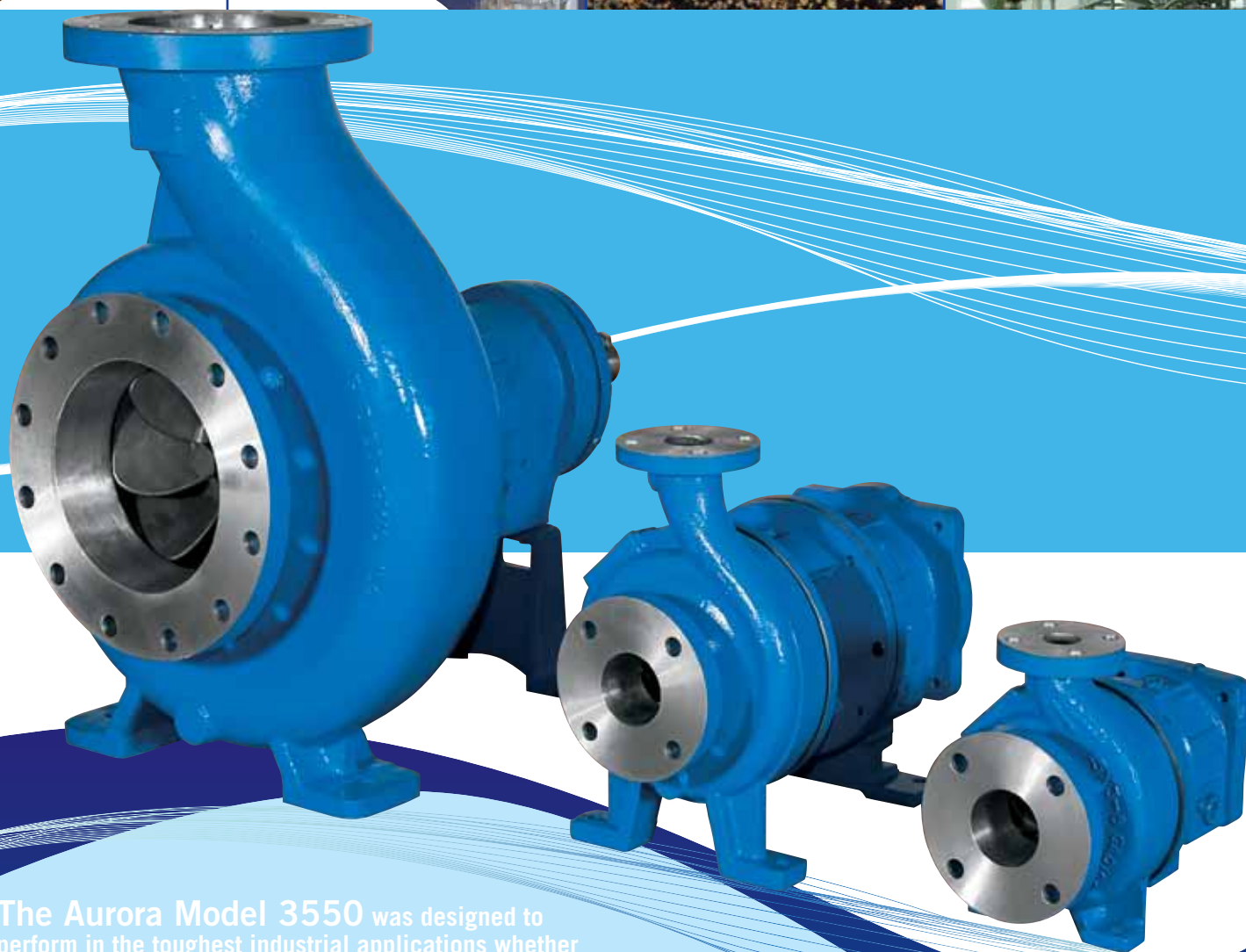

The Aurora Model 3550 was designed to perform in the toughest industrial applications whether in the chemical, petro-chemical, mining, pulp and paper, consumer products or general industry.

*If you are considering an ANSI pump for a motrallec application, look to Aurora Model 3550*

4 rue Lavoisier, ZA Lavoisier, 95223 HERBLAY CEDEX  
Tel. : 01.39.97.65.10 / Fax. : 01.39.97.68.48  
Demande de prix / e-mail : [service-commercial@motrallec.com](mailto:service-commercial@motrallec.com)  
[www.motrallec.com](http://www.motrallec.com)

# Model 3550

## Aurora Model 3550 S, M/L, XL

- Capacities to 4200 G.P.M. (954 m<sup>3</sup>/hr)
- Heads to 725 Feet (221 Meters)
- Temperatures to 650°F (343°C)
- Pressures to 375 PSIG (4998 kPa)

**Model 3550-S** 5 ASME/ANSI Pumps

**Model 3550-M/L** 14 ASME/ANSI Pumps

**Model 3550-XL** 5 ASME/ANSI Pumps

*The Aurora Model 3550-S, M/L, and XL were developed with the standard features required to withstand the most difficult applications and maximize mean-time-between-failures (MTBF).*





# Model 3550 Features

The Model 3550 power and wet ends were developed with the standard features required to withstand the most difficult applications and maximize mean-time-between-failures (MTBF).

## Labyrinth Oil Seals

- Prevents external contaminants
- Lower oil temperature

***Dramatically improves bearing life***

## Lubrication Flexibility

- Oil Flooded
- Oil Mist
- Greased

***Maximum lubrication options***

## Oversized Shaft

- Shaft deflection less than .002 in. per ANSI B73.1M

- Decreased Vibration

***Significantly increases both seal and bearing life***

## Heavy Duty Bearing

- Designed for maximum hydraulic loads
- Optional Duplex (40°/40° angular contact) thrust bearings

***Bearings can perform under the toughest conditions***

## External Impeller Adjustment

- Optimizes energy consumption
- Reduces repairs
- Simple external adjustments

***Long-term energy and repair savings***

## Large Capacity Oil Sump

- Cooler oil temperature
- Better heat transfer

***Increased bearing life***

## Large Sight Glass

- Assures proper oil levels
- Allows monitoring of oil condition

***Helps increase bearing life***

## Magnetic Drain Plug

- Removes magnetic particles

***Increases bearing life***

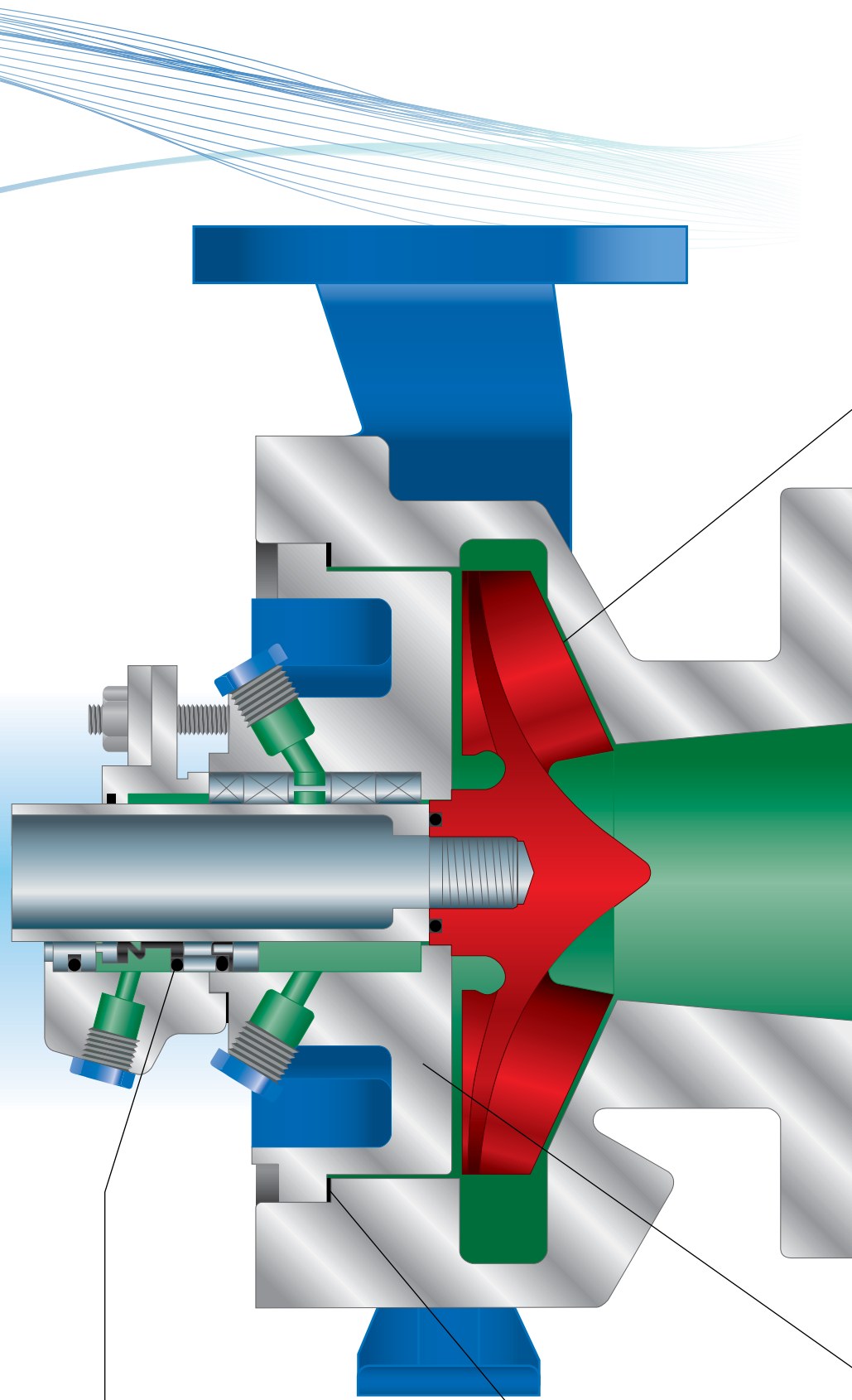

### Fully Open Impeller

- Back pump-out vanes
- Reduced radial/thrust loads
- Lower seal chamber pressure
- Double the wear area of a closed impeller

***Designed for the toughest applications including solids handling, stringy materials, abrasives and corrosives.***

### Heavy Duty Casing

- Class 150 flanges with Class 300 casing wall thickness
- Self-venting
- Back Pull-out design
- Integral cast feet
- Serrated flange surfaces
- Standard Class 150 FF and optional Class 150 RF, 300 FF/RF

***Designed for increased reliability, ease of maintenance and maximum life***

### Sealing Options

- Packing
- Conventional Single/Double
- Cartridge Single/Double

***Sealing options to accommodate most any fluid and temperature combinations***

### Positive Sealing

- Fully confined gasket
- Protects alignment fit

***Provides ease of maintenance and increased safety***

### Engineered Seal Chambers

- Standard Bore
- Large Bore
- Taper Bore

***Designed to provide optimum seal environment***

# Model 3550 Modular/Dimensional Interchangeability

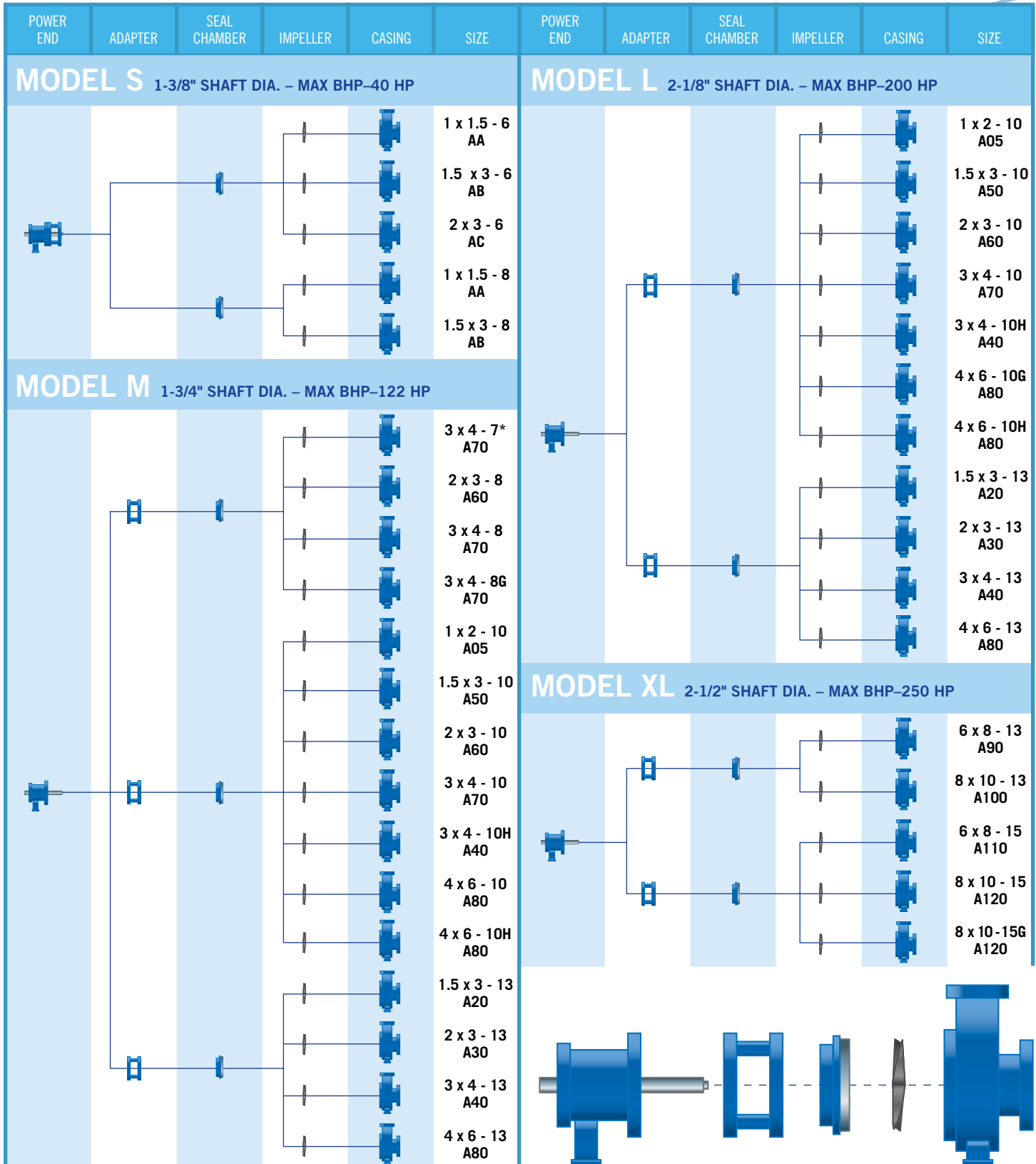

\*In the developmental stage.

# Model 3550 Parts & Material Composition

Item Number	Req' d Per Pump	Part Name	All Steel	All 316SS	All Alloy 20	All CD4MCu	All Titanium	B&C	
100	1	Casing	Steel	316SS	Alloy 20	CD4MCu	Titanium	B&C	
101	1	Impeller	Steel	316SS	Alloy 20	CD4MCu	Titanium	B&C	
105	1	Lantern Ring	Glass Filled Teflon*						
106	1	Packing	Teflon* Impregnated Fibers						
107	1	Packing Gland	316SS		Alloy 20		Titanium	B&C	
108	1	Frame Adapter	Ductile Iron						
112	1	Outboard (Thrust) Bearing	Double Row Angular Contact**						
122	1	Shaft – Less Sleeve (Optional)	316SS						
122	1	Shaft – With Sleeve	SAE4140				316SS		
126	1	Shaft Sleeve	316SS	316SS	Alloy 20	316SS	Titanium	B&C	
134	1	Bearing Housing	Cast Iron						
136	1	Lock Nut / Lock Washer	Steel						
168	1	Inboard (Radial) Bearing	Single Row Deep Groove						
184	1	Stuffing Box	Steel	316SS	Alloy 20	CD4MCu	Titanium	B&C	
228	1	Frame	Cast Iron (Ductile for Small Frame)						
241	1	Frame Foot	Cast Iron						
250	1	Gland	316SS		Alloy 20				
319	1	Sight Oil Gauge	316SS						
332A	1	Labyrinth Oil Seal (Outboard)	Bronze (Optional Carbon Filled Teflon)						
333A	1	Labyrinth Oil Seal (Inboard)	Bronze (Optional Carbon Filled Teflon)						
351	1	Casing Gasket	Aramid Fiber with EPDM Rubber						
353	4	Gland Stud	316SS						
355	4	Gland Nut	304SS						
357K	2	Hex Nut	304SS						
358A	1	Casing Drain Plug (Optional)	Steel	316SS	Alloy 20	316SS	Titanium	B&C	
360	1	Gasket, Frame-to-Adapter	Vellumoid						
360A	1	Gasket, Bearing End Cover	Vellumoid (XL Only)						
370	3	Bearing Housing Hex Bolt	Steel						
418	3	Casing Jack Screw	Steel						
469B	2	Dowel Pin	Steel						
496	1	Bearing Housing O-Ring	Buna Rubber						
496A	1	Impeller O-Ring	Glass Filled TFE						

\*E.I. Dupont Registered Trademark

\*\*NOTE: L Power End features Duplex Angular Contact.

Model	S	M	L	XL	
<b>Volute</b>	single				
<b>Nominal Case Thickness (inches)</b>	3/8	1/2 (4 x 6 - 13A80 = 5/8)	5/8	3/4	
<b>Corrosive Allowance @ Maximum</b>	1/8				
<b>Working Pressure</b>	Limits set by ANSI B16.5				
<b>Maximum Working PSIG</b>	See Pressure/Temperature charts				
<b>Hydro Test PSIG @ 100°F</b>	150% of working pressure at 100°F (38°C)				
<b>Maximum Liquid Temperature (°F)</b>	350°F without cooling / 650°F with cooling				
<b>Shaft Diameter</b>	At Coupling (inches)	3/8	1/2	5/8	3/4
	Sleeve Diameter Under Seal (inches)	1 1/8	1 1/4	1 3/8	1 1/2
	Under Impeller (inches)	3/4	1	1 1/4	1 1/2
	Under Sleeve (inches)	1 1/8	1 1/2	1 3/4	2
	Overhang (inches)	6 1/8	8 1/8	8 3/8	9 3/8

Model	S	M	L	XL	
<b>Bearings</b>	Radial	SKF 6207	SKF 6309	SKF 6311	SKF 6313
	Thrust	SKF 5306 A/C3	SKF 5309 A/C3	SKF 7310 BECBM	SKF 5313 A/C3
	Bearing Span	4 1/8	6 3/4	6 1/8	9 1/4
<b>Mechanical Seal Size (inches)</b>		1 3/8	1 3/4	2 1/8	2 1/2
<b>Stuffing Box – Standard Bore</b>	I.D. (inches)	2	2 1/2	2 3/8	3 1/8
	Depth (inches)	2 1/8	2 3/8		3
	Distance End of Box to Nearest Obstruction	2 1/2	2 13/16		2 15/16
<b>Stuffing Box – Large Bore</b>	I.D. (inches)	2 1/8	3 1/2	3 3/8	4 1/2
	Depth (inches)	2 1/8	2 3/8		3
	Distance End of Box to Nearest Obstruction	2 3/16	2 13/16		2.85
<b>Lantern Ring Width (inches)</b>		7/16	5/8	5/8	5/8

# Model 3550 Pump Dimensions

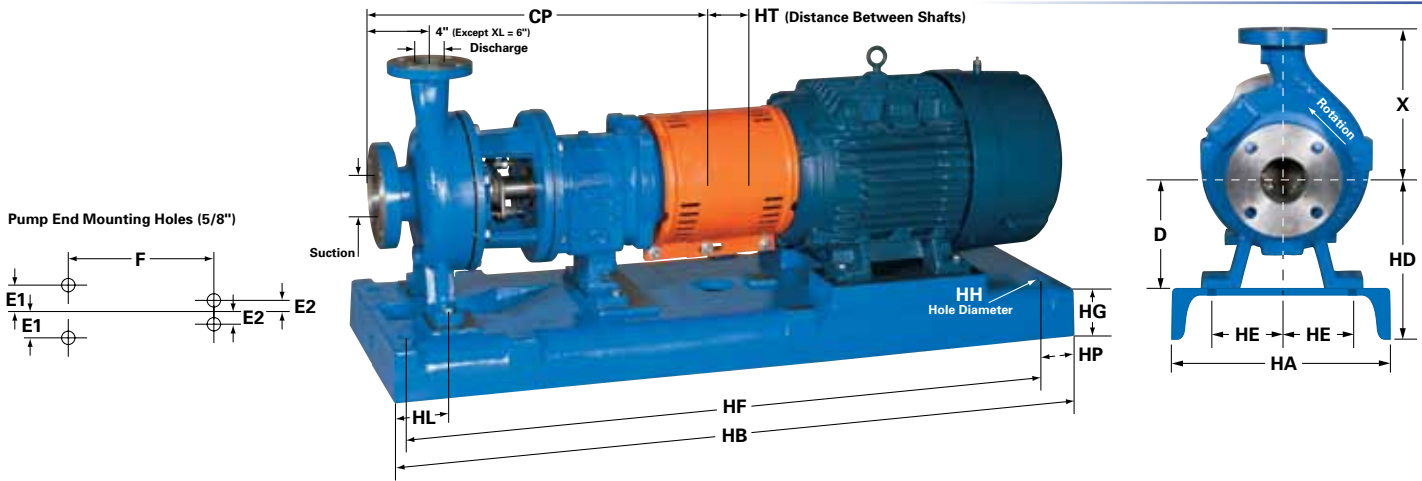

	Pump Size & Designation	ANSI Designation	Discharge	Suction	D	X	CP	E1	E2	F	Impeller Eye (square inches)	Maximum Diameter Solids
<b>S</b>	1 x 1½ - 6	AA	1	1½	5¼	6½	17½	3	0	7¼	3.1	1½/32
	1½ x 3 - 6	AB	1½	3	5¼	6½	17½	3	0	7¼	7.1	7/16
	2 x 3 - 6	AC	2	3	5¼	6½	17½	3	0	7¼	6.5	3/8
	1 x 1½ - 8	AA	1	1½	5¼	6½	17½	3	0	7¼	3.5	1½/32
	1½ x 3 - 8	AB	1½	3	5¼	6½	17½	3	0	7¼	4.4	7/16
<b>M</b>	2 x 3 - 8	A60	2	3	8¼	9½	23½	4⅞	3⅝	12½	5.4	½
	3 x 4 - 8	A70	3	4	8¼	11	23½	4⅞	3⅝	12½	12.5	1⅞
	3 x 4 - 8G	A70	3	4	8¼	11	23½	4⅞	3⅝	12½	11	1⅞/16
<b>M or L</b>	1 x 2 - 10	A05	1	2	8¼	8½	23½	4⅞	3⅝	12½	4.9	7/16
	1½ x 3 - 10	A50	1½	3	8¼	8½	23½	4⅞	3⅝	12½	6.5	7/32
	2 x 3 - 10	A60	2	3	8¼	9½	23½	4⅞	3⅝	12½	3.1	3/8
	3 x 4 - 10	A70	3	4	8¼	11	23½	4⅞	3⅝	12½	12.5	5/8
	3 x 4 - 10H	A40	3	4	10	12½	23½	4⅞	3⅝	12½	17.5	5/8
	4 x 6 - 10G	A80	4	6	10	13½	23½	4⅞	3⅝	12½	25.9	1
	4 x 6 - 10H	A80	4	6	10	13½	23½	4⅞	3⅝	12½	27.1	1
	1½ x 3 - 13	A20	1½	3	10	10½	23½	4⅞	3⅝	12½	4.9	7/32
	2 x 3 - 13	A30	2	3	10	11½	23½	4⅞	3⅝	12½	3.1	3/8
	3 x 4 - 13	A40	3	4	10	12½	23½	4⅞	3⅝	12½	14.2	5/8
<b>XL</b>	4 x 6 - 13	A80	4	6	10	13½	23½	4⅞	3⅝	12½	28	1
	6 x 8 - 13	A90	6	8	14½	16	33⅞	8	4½	18¾	45.5	1⅞/16
	8 x 10 - 13	A100	8	10	14½	18	33⅞	8	4½	18¾	56.7	1
	6 x 8 - 15	A110	6	8	14½	18	33⅞	8	4½	18¾	50	13/16
	8 x 10 - 15	A120	8	10	14½	19	33⅞	8	4½	18¾	74.6	1⅞
	8 x 10 - 15G	A120	8	10	14½	19	33⅞	8	4½	18¾	63	1⅞

	Maximum NEMA Frame	Baseplate Number	HA	HB	HT Minimum	D-8.25 HD	D-10 HD	HD	HE	HF	HG Maximum	HH	HL	HP
<b>S</b>	184T	139	12	39	3.5	9	N/A	N/A	4.5	36½	3¼	0.75	4.5	1¼
	256T	148	15	48	3.5	10½	N/A	N/A	6	45½	4⅞	0.75	4.5	1¼
	326TS	153	18	53	3.5	12⅞	N/A	N/A	7.5	50½	4⅞	0.75	4.5	1¼
<b>M or L</b>	184T	245	12	45	3.5	12	13¾	N/A	4.5	42½	3¼	0.75	4.5	1¼
	215T	252	15	52	3.5	12⅞	14⅞	N/A	6	49½	4⅞	0.75	4.5	1¼
	286T	258	18	58	3.5	13	14¾	N/A	7.5	55½	4⅞	1	4.5	1¼
	365T	264	18	64	3.5	13⅞	14¾	N/A	7.5	61½	4⅞	1	4.5	1¼
	405TS	268	24	68	3.5	14⅞	14¾	N/A	9.5	65½	4⅞	1	4.5	1¼
	449TS	280	24	80	3.5	15⅞	15⅞	N/A	9.5	77½	4⅞	1	4.5	1¼
<b>XL</b>	286T	368	24	68	5	N/A	N/A	19¼	9.5	65½	4⅞	1	6.5	1¼
	405T	380	24	80	5	N/A	N/A	19¼	9.5	77½	4⅞	1	6.5	1¼
	449T	398	24	98	5	N/A	N/A	19¼	9.5	95½	4⅞	1	6.5	1¼

# 3500 Series Model 3550 Options

The Aurora Model 3550 has a broad range of engineered options and upgrades that will support a variety of process requirements and meet most any fluid processing application.

## Drivers

- Electric Motors  
ODP / TEFC / XP
- Variable Frequency Drives

## Oil Temperature Control

- Bearing Frame Cooling Coil

## Seal Flush / Cooling

- Most ASME/ANSI B73.1M seal  
flush and cooling plans available

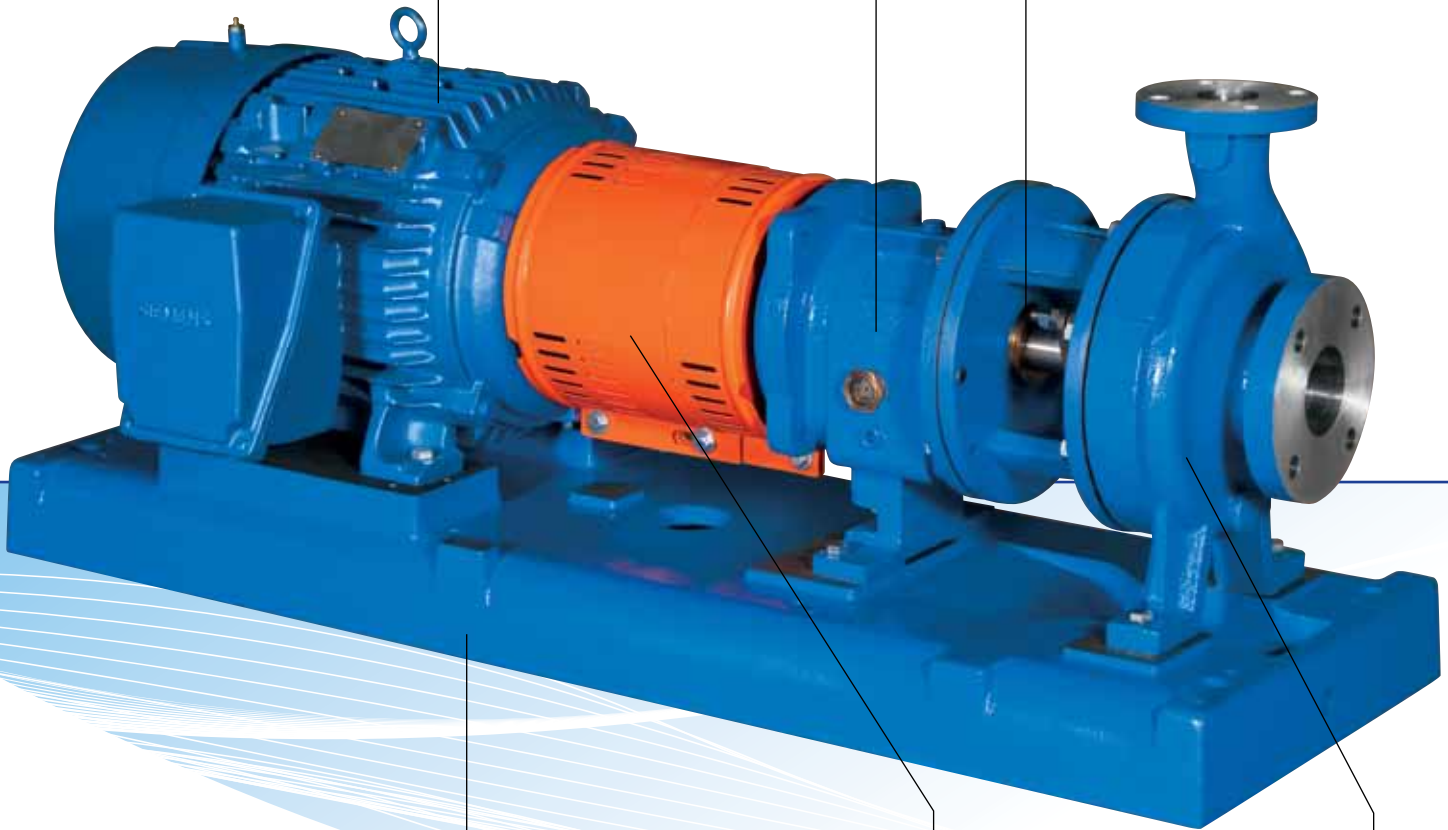

## Mounting Baseplates

- Fabricated Steel per  
ASME/ANSI B73.1M
- Cast Iron in compliance with PIP
- Heavy-duty epoxy resin based  
polymer composite to  
ASME/ANSI B73.1M

## Couplings and Guards

- OSHA approved coupling guards
- Various coupling options

## Process Temperature Control

- Jacketed Casings
- Jacketed Seal Chamber

# THE AURORA family of pumps has the right pump for your industrial application

Regenerative Turbine | Condensate  
Boiler Feed | End Suction  
Split Case | Sump  
ASME/ANSI

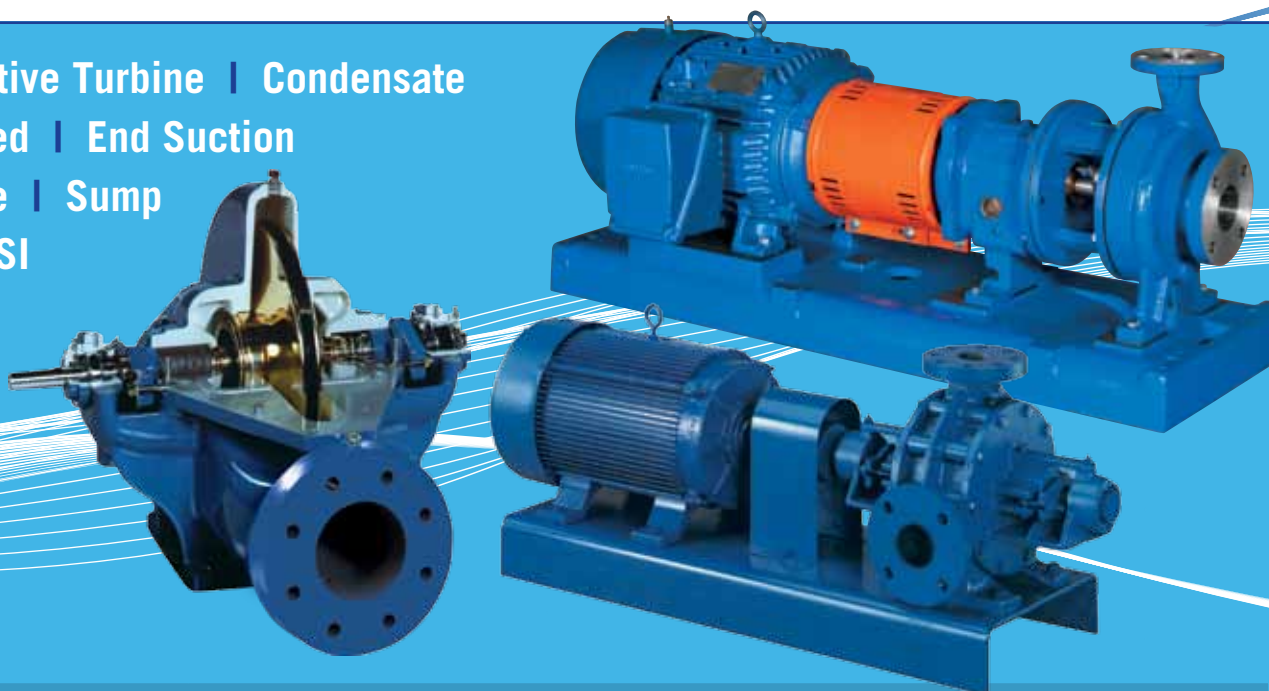

Product Performance Ranges	Maximum Capacity Range*		
PUMP CATEGORY	Flow – GPM/M <sup>3</sup> /hr. (meters cubed/hr.)	Head – ft./m.	Temp. – °F/°C
ASME/ANSI	4200 / 953.4	725 / 220.9	-100-650 / -73-343
Regenerative Turbine	50-150 / 11.4-34.1	700-1,200 / 213-366	212-500 / 100-260
Condensate	150-180 / 34.1-40.9	170-270 / 52-82	190-200 / 88-93
Boiler Feed	100 / 22.7	575 / 175	210 / 99
End Suction	140-4,500 / 31.8-1,022.1	55-790 / 17-41	225-300 / 107-149
Split Case	400-15,000 / 90.8-3,406.9	500-1,000 / 152-305	275-300 / 135-149
Sump	100-1,200 / 22.7-272.5	40-180 / 12-55	180 / 82

\* Capacity range indicates multiple series in one pump category. See product sheets for complete specifications.

Since its founding in 1919, Aurora has become a leading supplier devoted to manufacturing a wide variety of pumps and systems for an ever-expanding variety of markets and applications. Prime examples of our industrial applications include process water supply, spray booth, cooling water supply, transfer and recirculation pumping equipment.

Aurora's commitment to excellence goes beyond the product line, as we're dedicated to keeping customers up-to-date on the latest developments in flow technology. From Aurora's broad selection of pumps and related products, Aurora's design engineering programs assist with selecting the best pumps and systems along with providing pump drawings and specifications. These programs save valuable time in the selection and evaluation of pumps and systems.

Contact your authorized Pentair Industrial Pumps distributor for more information on our entire industrial pump offering.

**NOTE:** Aurora Pump reserves the right to make revisions to its products and their specifications, and to this bulletin and related information, without notice.



**motralec**

4 rue Lavoisier . ZA Lavoisier . 95223 HERBLAY CEDEX  
Tel. : 01.39.97.65.10 / Fax. : 01.39.97.68.48  
Demande de prix / e-mail : service-commercial@motralec.com  
[www.motralec.com](http://www.motralec.com)



Fiche produit Motralec Aurora 3500 3550 - fiche technique | Motralec

■ **DEMANDE DE PRIX RAPIDE** : <https://www.motralec.com/demandeContact>