

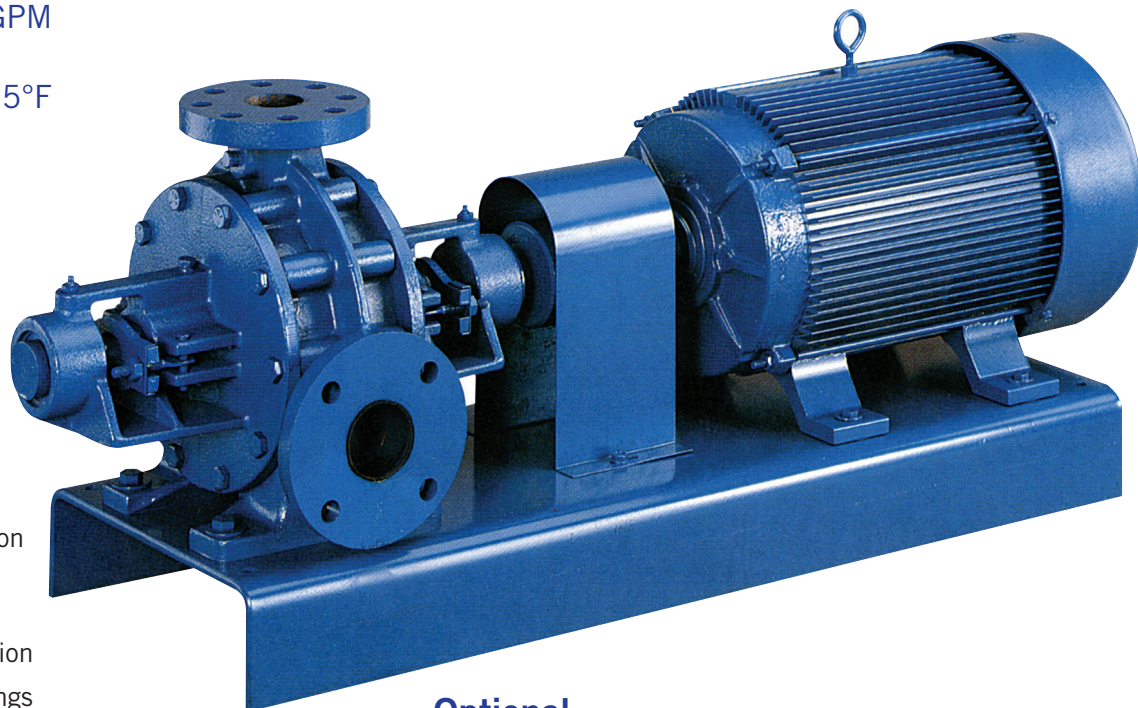

110A Series "APCO" One & Two Stage Turbine Type Pumps

- Capacities to 150 GPM
- Heads to 700 Feet
- Temperatures to 275°F



Standard

- Bronze fitted construction
- Hydraulically balanced bronze impeller
- Right- or left-hand rotation
- Regreaseable ball bearings
- Short bearing span
- Mechanical seals or graphite impregnated acrylic packing
- 416 hardened stainless steel shaft
- Floating impellers
- Removable channel rings
- VIP Test – Every pump is given a hydrostatic test at 1½ times rated pressure along with a running test for head and capacity performance check

Optional

- All iron, bronze ring or all bronze construction
- 316 stainless steel or Monel® shaft
- External sealing line to stuffing box
- Lantern ring (5 & 6 series 110)
- Formed steel or drip-rim bases
- Bypass with manual shut-off valves
- Bypass with relief valve
- Self-priming features
- Certified performance test data can be supplied consisting of head, capacity and horsepower readings taken over the full operating range of the pump

motralec

4 rue Lavoisier . ZA Lavoisier . 95223 HERBLAY CEDEX
Tel. : 01.39.97.65.10 / Fax. : 01.39.97.68.48

Demande de prix / e-mail : service-commercial@motralec.com

www.motralec.com

Aurora 110A Series Pumps

Reliable Pumping Service

Apco regenerative turbine pumps are field-proven throughout the world. Apco pumps are ideal for handling (1) high head/low flow requirements, (2) liquids entrained with gases and vapors (up to 20%), and (3) constant flows.

You are assured of reliable pumping service because every Apco is tested to ensure consistent performance.

Apco pumps are designed for those special applications where high head and low flow are required by the system. Boiler feed systems, for example, require high pressure to get low flows of water into the pressurized steam boiler.

Conventional centrifugal pumps, in contrast, must operate close to shutoff or operate at high speed to meet these high head/low flow requirements. These misapplications can cause high vibration, mechanical damage, frequent maintenance, and excessive energy use.

Apco pumps thrive in high head/low flow applications so you save on operating costs (less maintenance, downtime and energy costs).

Increase System Reliability with Constant Flow

Apco pumps assure constant flow when you need it. The steep performance curve allows for minimal changes in the capacity even with large pressure variations.

The constant flow characteristics make the Apco ideal for cooling systems where it is vital that sufficient flow is maintained to dissipate heat despite changes in pressure.

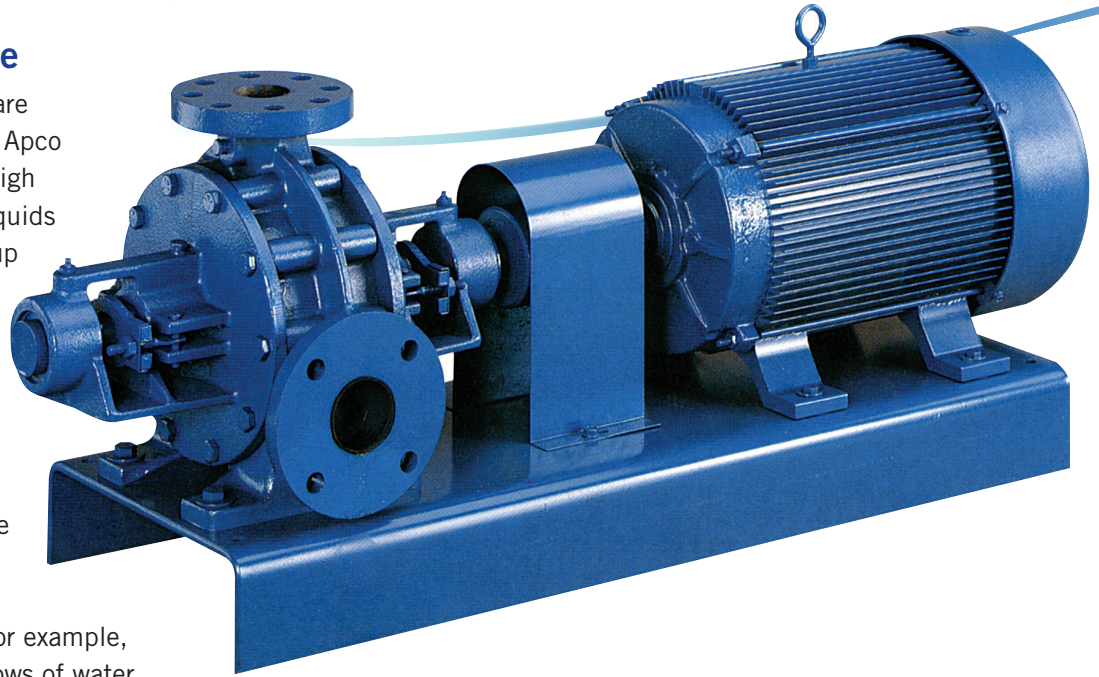

Pressure variations occur for a number of reasons. The most common designed-in variations are caused by automatic pop-off valves and similar control devices.

With Apco pumps, you can always depend on the same capacity despite variations in head pressure and achieve increased system reliability.

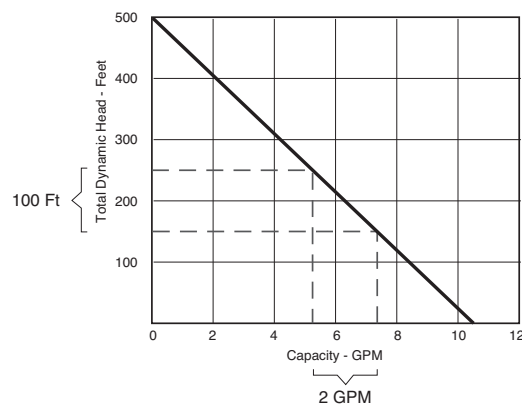

The curve above shows that with a 100 foot change in head, the capacity varies only 2 gallons per minute. You get a virtually constant flow over wide pressure variations to ensure reliable system operation.

Aurora 110A Series Pumps

Applications

- Boiler Feed
- Condensate Return
- Cooling Systems
- High Pressure Spray
- Booster Systems
- Jockey Pumps
- Chlorine Injection
- Chemical Feed Systems
- Laundry and Dry Cleaning Systems
- Laser Cooling
- Electrostatic Discharge Machines
- TV Tube and CRT Manufacturing
- Car Washes

Benefits

- Reliability
- Years of Field-proven Service
- Reduce Energy Consumption
- Trouble-free Operation
- High Performance
- Save Space
- Versatility
- Complete Technical Support
- Low Flow/High Head Capabilities

Limitations

Max. hydrostatic test pressure..... 450 psi
except G6-H6-J6-K6..... 265 psi

Max. case working pressure 300 psi
except G6-H6-J6-K6..... 175 psi

Max. suction pressure 175 psi
except two stage 116 Series
with optional 250 lb. suction flange 300 psi

Max. recommended packing box pressure . 100 psi

Max. recommended mechanical
seal chamber pressure 250 psi
except 114A, 4R, 4RTL 150 psi

Box or seal chamber pressure equals –
One stage: suction pressure plus 60%
differential pressure.

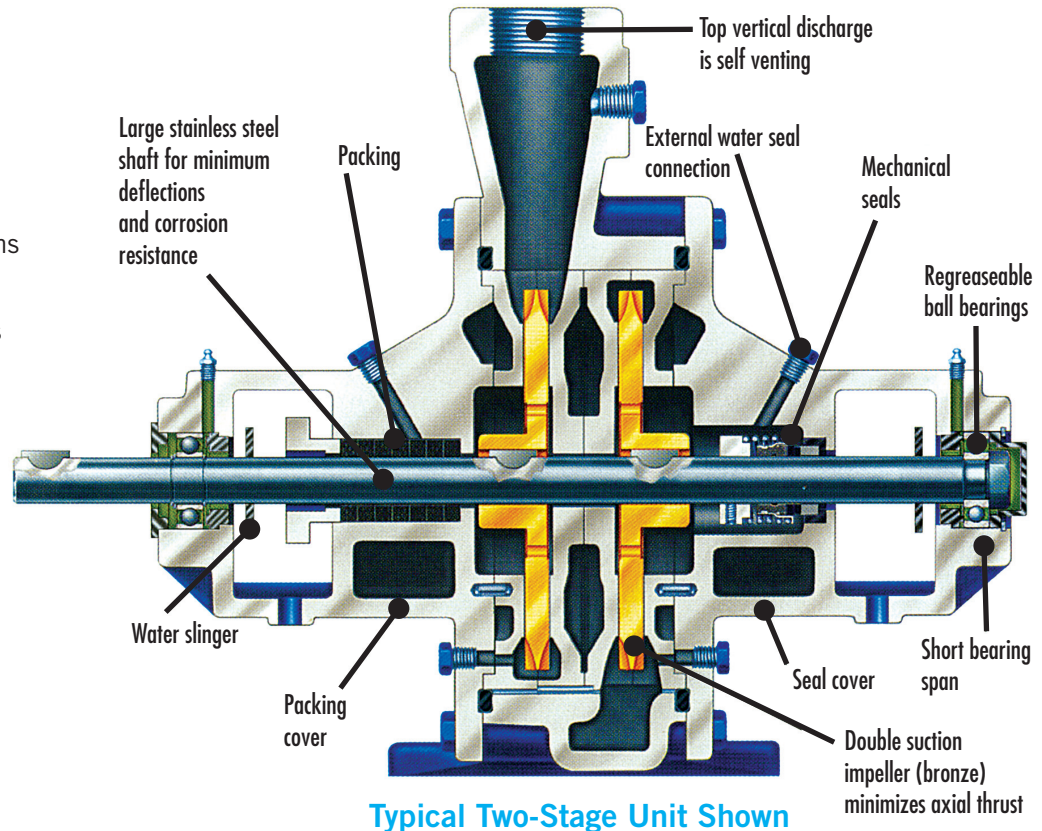

Two stage: 1st stage equals – suction pressure plus 30% differential,
2nd stage equals – suction pressure plus 80% differential.

Max. temperatures

*Packing..... 275°F
Std. mechanical seal.....225°F
Hi-temp mechanical seal.....275°F

*Packing.....Suction lift requires lantern ring,
115 and 116 Series only.

Selection Charts

1750 RPM

Capacity GPM	Total Dynamic Head in Feet																								
	10	20	30	40	50	60	70	80	100	115	130	145	160	180	200	220	240	260	280	300	350	400	450	500	
2	B4 ½	B4 ½	A35 ½	A35 ½	A35 ½	A4 ½	A4 ½	A4 ½	C4 ½	D4 ½	D4 ½	D4 ½	D4 ½	D4 ¾	D4 ¾	D5 1	D5 1	D5 1	D4T 1	D4T 1½	D4T 1½	E4T 1½	G4T 3	D5T 3	
5	C4 ½	C4 ½	D4 ½	D4 ½	D4 ½	D4 ½	D4 ½	D4 ½	D4 ½	E4 ½	F4 1	F4 1	F4 1	F4 1	G4 1	G4 1½	G4 1½	F4T 1½	F4T 2	F4T 2	G4T 2	G4T 3	G4T 3	G5T 3	
10	F4 ½	F4 ½	F4 ½	F4 ½	F4 ½	G4 ¾	G4 ¾	G4 ¾	G4 1	G4 1	G4 1	I4 1½	I4 1½	I4 1½	G4T 1½	G4T 2	G4T 2	I4T 2	I4T 3	H5 3	H5 3	G5T 5	G5T 5	H5T 5	
15	G4 ½	G4 ½	G4 ½	H4 ¾	H4 ¾	H4 1	H4 1	H4 1	I4 1	I4A 1½	I4A 2	I4A 2	I4T 2	I4T 2	I4TA 3	I4TA 3	I4TA 3	I4TA 3	I5 5	I5 5	I5 5	H5T 5	H5T 5	I5T 7½	
20	H4 ¾	H4 ¾	H4 ¾	H4 ¾	H4 ¾	I4 1	I4A 1½	I4A 1½	I4A 1½	I4TA 1½	I4TA 2	I4TA 3	I4TA 3	I4TA 3	I4TA 3	I5 5	I5 5	I5 5	I5 5	I5 5	I5 5	I5 7½	I5T 7½	D6T 10	D6T 10
25	I4A ¾	I4A ¾	I4A ¾	I4A 1	I4A 1	M4A 1½	M4A 1½	M4A 1½	M4 2	M4 3	R4 3	I5 3	I5 3	I5 3	J5 5	J5 5	K5 7½	L5 7½	L5 10	L5 10	L5 10	I5T 7½	D6T 10	E6T 15	
30	I4A ¾	I4A ¾	M4 1	M4 1	M4 1	M4A 1½	M4A 1½	M4A 1½	P4 3	R4 3	J5 3	J5 5	J5 5	K5 5	K5 5	L5 7½	L5 7½	L5 7½	L5 10	L5 10	L5 10	E6T 15	E6T 15	E6T 15	
35	M4 ¾	M4 ¾	M4 1	M4 1	M4 1	M4A 1½	P4 2	P4 2	P4 3	L5 5	K5 5	K5 5	L5 5	L5 5	L5 7½	L5 7½	L5 7½	L5 7½	G6 10	G6 10	E6T 10	E6T 15	F6T 15	G6T 20	
40	M4 ½	M4 ¾	M4 1	M4 1	M4 1	P4 2	P4 2	P4 2	R4 3	L5 5	L5 5	L5 5	L5 7½	L5 7½	L5 7½	L5 10	G6 10	G6 10	G6 10	E6T 10	F6T 15	F6T 15	G6T 20	G6T 20	
50	P4 1	P4 1½	P4 1½	P4 1½	R4 2	R4 2	R4 3	L5 3	L5 5	L5 5	L5 5	L5 5	L5 5	P5 10	P5 10	H6 10	F6T 10	F6T 10	F6T 10	G6T 15	G6T 15	G6T 15	G6T 20		
60	R4 1½	R4 1½	R4 1½	R4 2	L5 3	L5 3	L5 3	L5 5	L5 5	P5 7½	P5 7½	P5 10	P5 10	P5 10	H6 10	J6 15	G6T 15	G6T 15	G6T 15	G6T 15	G6T 15	J6T 25	J6T 25		
70	L5 2	L5 3	L5 3	L5 3	L5 3	N5 3	N5 3	N5 5	P5 7½	P5 7½	P5 7½	P5 10	P5 10	H6 10	J6 15	J6 15	G6T 15	G6T 15	H6T 15	H6T 15	J6T 20	J6T 25	K6T 30		
80	M5 1½	M5 1½	N5 2	N5 3	N5 3	N5 3	P5 5	P5 7½	P5 7½	P5 7½	P5 10	H6 10	J6 10	J6 10	J6 10	K6 15	H6T 15	H6T 15	H6T 15	H6T 15	J6T 20	J6T 20	K6T 25		
90	N5 2	N5 2	N5 2	P5 5	P5 5	P5 5	P5 5	P5 7½	P5 7½	P5 7½	J6 10	J6 10	J6 10	J6 10	K6 15	H6T 15	H6T 15	J6T 20	J6T 20	J6T 20	K6T 25	K6T 25			
100	N5 2	P5 5	P5 5	P5 5	P5 5	P5 5	P5 5	P5 7½	P5 7½	J6 10	J6 10	J6 10	J6 10	K6 15	J6T 15	J6T 15	J6T 20	J6T 20	J6T 20	J6T 20	K6T 20	K6T 25			
120	P5 5	P5 5	P5 5	P5 5	P5 5	P5 5	J6 7½	J6 7½	J6 7½	J6 10	K6 10	K6 10	J6T 15	J6T 15	J6T 15	K6T 20	K6T 20	K6T 20							
150	J6 5	J6 5	J6 5	J6 5	J6 5	K6 7½	K6 7½	K6 7½	K6T 10	K6T 15	K6T 15	K6T 15													

Design Details

Area	Dimensions	110-Series Pump Model				
		A35- I4A	M4- R4	D5- I5	J5- P5	G6- K6
		D4T- I4TA		D5T- I5T		D6T- K6T
Stuffing Box	Packing Rings Per Box	4	5	7	7	8
	Packing Size (Square)	¼"	⅜"	¼"	¼"	⅝"
Shaft	Outside Diameter of Shaft	.590	.787	.787	.984	1.181
Ball Bearings	Inboard Radial	202	204	204	205	206
	Outboard Thrust	300K	303K	303K	304K	305K

3500 RPM

Capacity GPM	Total Dynamic Head in Feet								
	50	100	150	200	250	300	350	400	450
2	B4 ½	B4 ½	B4 ¾	B4 ¾	A35 1	A35 1	A4 1½	A4 1½	A4 2
4	B4 ½	A35 ¾	A35 ¾	A35 1	A4 1	A4 1½	D4 3	D4 5	D4 5
6	A35 ½	A4 ¾	A4 ¾	C4 1½	D4 3	D4 3	D4 3	D4 5	D4 5
8	C4 ¾	C4 ¾	C4 1	D4 3	D4 3	D4 3	D4 3	D4 5	D4 5
10	C4 ¾	D4 2	D4 2	D4 3	D4 3	D4 3	D4 3		
12	D4 1½	D4 2	D4 2	D4 3	D4 3				
14	D4 1½	D4 2	D4 2						
15	D4 1½	D4 2							

Pump Dimensions

Type 4 & 5 Series

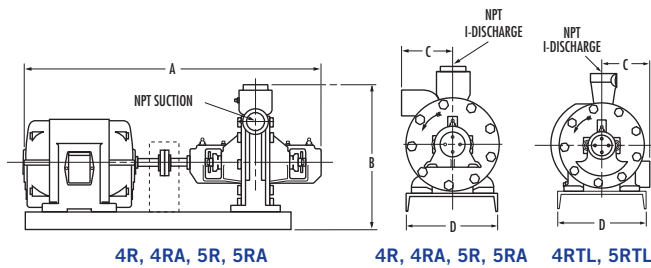

4R, 4RA, 5R, 5RA

4R, 4RA, 5R, 5RA

4RTL, 5RTL

Type 6 Series

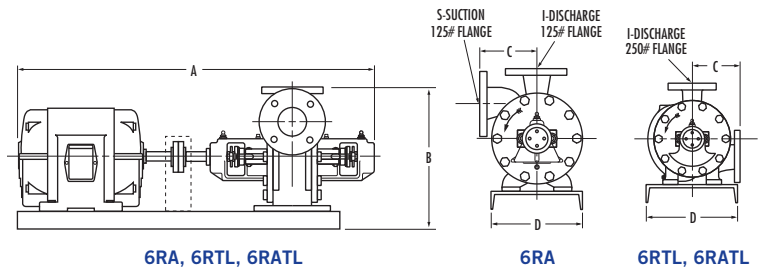

6RA, 6RTL, 6RATL

6RA

6RTL, 6RATL

SINGLE STAGE												TWO STAGE				
4R	A35, A4, B4, C4, D4, E4 F4, G4, H4, I4, I4A				4RA	M4, P4, R4				NEMA Motor Frame	1750 RPM HP	4RTL	D4T, E4T, F4T, G4T, I4T, I4TA			
Unit Weight	Discharge 1¼"		Suction 1¼"		Unit Weight	Discharge 1½"		Suction 1½"				Unit Weight	Discharge 1¼"		Suction 1¼"	
	A	B	C	D		A	B	C	D		A	B	C	D		
86	24	12	4	7	125	27	11	4	9	56	½, ¾	125	25	11	4½	9
66	22	13	4	7	108	25	12	4	9	143T	1	105	23	12	4½	9
71	23	13	4	7	113	26	12	4	9	145T	1½-2	110	24	12	4½	9
95	24	13	4	9	126	27	12	4	10	182T	3	126	25	13	4½	10
100	25	13	4	9	131	28	13	4	10	184T	5	131	26	13	4½	10
161	27	14	4	10	195	30	14	4	12	213T	7½	195	28	14	4½	12
181	29	14	4	10	215	32	14	4	12	215T	10	215	30	14	4½	12
5R	D5, E5, F5, G5, H5, I5				5RA	J5, K5, L5, M5, N5, P5				NEMA Motor Frame	1750 RPM HP	5RTL	D5T, E5T, F5T, G5T, H5T, I5T			
Unit Weight	Discharge 1¼"		Suction 1¼"		Unit Weight	Discharge 1½"		Suction 2"				Unit Weight	Discharge 1¼"		Suction 1¼"	
	A	B	C	D		A	B	C	D		A	B	C	D		
125	28	15	5	9						56	½, ¾					
111	26	15	5	10	128	28	15	5	10	143T	1	128	28	15	5	10
116	27	15	5	10	133	29	15	5	10	145T	1½-2	133	29	15	5	10
126	28	15	5	10	143	30	15	5	10	182T	3	143	30	15	5	10
133	29	15	5	10	148	31	15	5	10	184T	5	148	31	15	5	10
195	31	16	6	12	214	33	16	5	12	213T	7½	214	33	16	5	12
219	33	16	5	12	234	35	16	5	12	215T	10	234	35	16	5	12
332	26	18	5	13	347	38	18	5	13	254T	15	346	38	18	5	13
357	38	18	5	13	381	40	18	5	13	256T	20	381	40	18	5	13
6RA	G6, H6, J6, K6				NEMA Motor Frame	1750 RPM HP	6RTL	D6T, E6T, F6T				6RATL	G6T, H6T, J6T, K6T			
Unit Weight	Discharge 2½"		Suction 3"				Unit Weight	Discharge 2"		Suction 2½"		Unit Weight	Discharge 2½"		Suction 3"	
	A	B	C	D		A	B	C	D		A	B	C	D		
245	35	18	6½	12	182T	3	264	35	17	6½	12	325	38	17	7	15
249	36	18	6½	12	184T	5	369	36	17	6½	12	330	39	17	7	15
341	38	19	6½	13	213T	7½	361	38	18	6½	13	390	41	17	7	15
361	40	19	6½	13	215T	10	381	40	18	6½	13	410	43	17	7	15
436	43	19	6½	13	254T	15	456	43	18	6½	13	490	46	17	7	15
475	45	18	6½	15	256T	20	495	45	17	6½	15	515	48	17	7	15
545	46	19	6½	15	284T	25	565	46	18	6½	15	585	49	18	7	15
575	48	19	6½	15	286T	30	595	47	18	6½	15	649	50	19	7	18

1. Dimensions and weights are approximate.
2. Dimensions are in inches and may vary $\pm 1/8"$.
3. Not for construction purposes unless certified.
4. Frame sizes shown are for open dripproof motors only.
5. Conduit box is shown in approximate position.
Dimensions are not specified as they vary with each motor manufacturer.
6. All flanges are standard flat face.

NOTES:

1. Selections indicate pump size in upper portion and motor HP in lower portion of each block.
2. A35, A4, B4, C4 and D4 pumps are also available for 3500 RPM operation.
See table on page 4.
3. Maximum suction pressure is based on suction flange pressure rating.
4. All limitations are based on standard pumps constructed of standard materials and handling water.

Specifications

The contractor shall furnish (and install as shown on the plans) an Apco regenerative turbine type pump model ____ size ____ (Bronze Fitted) (Bronze Ring) (All Iron) (All Bronze). Each pump shall have a capacity of ____ GPM when operating at a total head of ____ feet at the specified temperature, viscosity, specific gravity, and NPSH. The speed of the pump shall not exceed 1750 RPM. (Models A35, A4, B4, C4 and D4 can also be operated at 3500 RPM.) The pump is to be furnished with (mechanical seals) (packing). The pump shall be of vertically split case design with removable bearing housings, and the channel rings shall be replaceable without replacing the bearing housings. The suction and discharge connections shall be cast integral with the casing. The discharge shall be in a vertical position and the pump shall be self-venting. The casing and bearing housings shall be cast of 30,000 pound tensile strength cast iron. The impeller(s) shall be located on the stainless steel shaft between grease lubricated ball bearings. The impeller shall be hydraulically self-centering and no external adjustment shall be necessary. Each pump shall be tested prior to shipment. The pump shall be mounted on a (steel drip rim) (steel) baseplate and flexibly coupled to a ____ HP ____ phase, ____ hertz, ____ voltage, ____ RPM, horizontal (dripproof) (totally enclosed) (explosion proof) motor. The motor shall be sized to prevent overloading at the highest head condition listed in the specifications.

Materials of Construction

Retainer	Nylon
Bearing Covers	Cast Iron – ASTM A48
Casing	Cast Iron – ASTM A48
Channel Rings	Cast Iron – ASTM A48
Glands	Cast Iron – ASTM A48
Impellers	Bronze – ASTM B62
Packing	Graphited Teflon® Fiber
Shaft	Stainless Steel – AISI 416

Maximum Differential Pressure

Pump Sizes	psi
R4	90
J6, K6	100
P4	110
I4A, M4, I4TA, P5, H6	125
I4, I4T, H5, I5, M5, N5, G6	150
L5	175
A35, A4, B4, C4, D4, E4, F4, G4, H4, G4T	200
K5	220
G5	225
J5	230
F4T, D5, E5, F5, H5T, I5T, J6T, K6T	250
D4T, E4T, D5T, E5T, F5T, G5T, D6T, E6T, F6T, G6T, H6T	300

NOTE: Maximum differential pressure based on allowable shaft deflection for standard shafts.

Maximum Horsepower

Pump Sizes	HP
E4, F4, G4, H4, I4, I4A, D4T, E4T, F4T, G4T, I4T, I4TA	4
A35, A4, B4, C4, D4	7½
M4, P4, R4, D5, E5, F5, G5, H5, I5, D5T, E5T, F5T, G5T, H5T, I5T	10
J5, K5, L5, M5, N5, P5	20
G6, H6, J6, K6, D6T, E6T, F6T, G6T, H6T, J6T, K6T	40

motralec

4 rue Lavoisier . ZA Lavoisier . 95223 HERBLAY CEDEX
Tel. : 01.39.97.65.10 / Fax. : 01.39.97.68.48
Demande de prix / e.mail : service-commercial@motralec.com

www.motralec.com



A-02-1004 07.10