

**CATALOGO
GENERALE**

***GENERAL
CATALOGUE***

motralec

4 rue Lavoisier . ZA Lavoisier . 95223 HERBLAY CEDEX

Tel. : 01.39.97.65.10 / Fax. : 01.39.97.68.48

Demande de prix / e-mail : service-commercial@motralec.com

www.motralec.com

AIR COMPRESSOR

CATALOGO GENERALE

AIR COMPRESSOR

Note tecniche di prodotto

I dati e le caratteristiche tecniche riportate nel presente Catalogo Generale non sono impegnativi. La SPERONI S.p.a. si riserva il diritto di apportare qualsiasi modifica senza alcun preavviso. Per tanto pesi, misure, prestazioni e quanto altro indicato non sono vincolanti, ma solo indicativi. In ogni caso, per qualsiasi dettaglio tecnico richiedere direttamente alla SPERONI S.p.a. la scheda tecnica aggiornata del prodotto.

Foro Competente

Per eventuali controversie, il Foro competente sarà quello di Reggio Emilia anche se il pagamento è avvenuto a mezzo tratta.

Technical Characteristics

The technical data and characteristics stated in this General Catalogue are not binding. SPERONI S.p.a. reserves the right to make modifications without notice. Therefore weights, dimensions, performances and any other stated issues are indicative only and not binding. Anyway for any technical details you must require an up-to-date product technical card.

Competent Court

In case of any dispute the competent Court will be one of Reggio Emilia even if the payment is by bill of exchange.

 **Revisione 07 - 03/2012**



pag. 7

BRICO



pag. 17

**CRM 101
102-103**



pag. 26

**CFV 100
VERTICAL**



pag. 8

PAC 2500



pag. 18

**CRM
152**



pag. 27

**CFV 200
VERTICAL**



pag. 9

CH 10



pag. 19

**CRM
203**



pag. 28

**CFV 300
VERTICAL**



pag. 10

CH 25-50



pag. 20

**CR
303
304-305**



pag. 29

MICRO



pag. 12

CHB 20/230



pag. 21

**CR
505
507-510**



pag. 30

**CRS
1040-1055**



pag. 13

**CHB
25-50-100**



pag. 22

**CF 1010
EXPORT**



pag. 31

**TTS
2255
2265**



pag. 14



TT 22 MT

pag. 23

**TANDEM
500**



pag. 32

**TTS
3465**

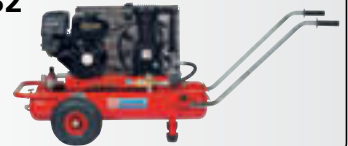

pag. 15

CRM 23-24



pag. 24

**TANDEM
900**



pag. 33

**TTS
3490**



pag. 16

**CRM
50-51-52**



pag. 25

**TANDEM
1000
EXPORT**



pag. 34

**TTS
34110**



pag. 35

CRD 1042



pag. 44

CRD 104

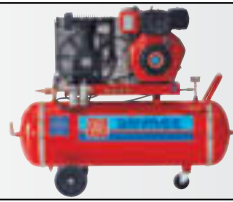

pag. 53

AGRIPLUS
1000/1000
1500/1000



pag. 36

TTD 2242



pag. 45

CRD
206-309-509



pag. 54

MT

GRUPPO COMPRESSORE SU BASE
COMPRESSORS GROUPS ON BASEPLATES



pag. 37

TTD
3460



pag. 46

AGRITECH
540



pag. 55

CH

COMPRESSORI COASSIALI
MONOCILINDRICI
SINGLE CYLINDER DIRECT
DRIVEN COMPRESSORS



pag. 38

TTD
3496



pag. 47

AGRITECH
650



pag. 55

CHB

COMPRESSORI
COASSIALI BICILINDRICI
TWO-CYLINDERS DIRECT
DRIVEN COMPRESSORS



pag. 39

KIT EASY
260



pag. 48

AGRITECH
1000



pag. 56

K8 - K11

COMPRESSORI MONOSTADIO
SINGLE-STAGE COMPRESSORS



pag. 40

KIT
EASY
430



AGRIMASTER
650



pag. 57

K17 - K18

COMPRESSORI MONOSTADIO
SINGLE-STAGE COMPRESSORS



pag. 41

KIT
PROFI
520



AGRIMASTER
1000



pag. 58

K28- K30

COMPRESSORI BISTADIO
TWO-STAGE COMPRESSORS



pag. 42

CRS
54-104
155-206



AGRIMASTER
1500



pag. 59

K50- K60

COMPRESSORI BISTADIO
TWO-STAGE COMPRESSORS



pag. 43

CRS
309-511



pag. 52

AGRIPLUS
1000/500
1500/500



pag. 78-88

ACCESSORI
ACCESSORIES



pag. 60



KIT POWER 300

pag. 66



**CRM-CR
52-5 PL**

pag. 72



**CRM-CR
203 PL**

pag. 61



KIT POWER 500

pag. 67



**CRM-CR
102 PL**

pag. 73



**CF-CR
304 PL**

pag. 62



PAC 2000 PL

pag. 68



**CRM-CR
102-5 PL**

pag. 74



**CF-CR
305 PL**

pag. 63



CH 25/210 PL

pag. 69



**CRM-CR
103 PL**

pag. 75



**CF-CR
505 PL**

pag. 64



CH 50/210 PL

pag. 70



**CRM-CR
152 PL**

pag. 76



CH 210 PL

pag. 65



CRM-CR 52 PL

pag. 71













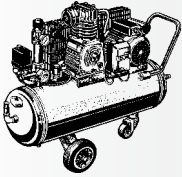
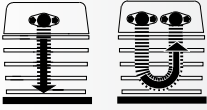







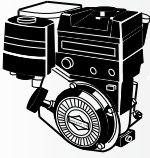

**CRM - CR
153 PL**

pag. 76-77

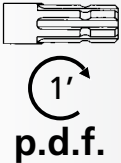
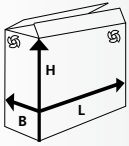
A - KC

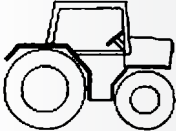

LEGENDA SYMBOLS -

 <p>Tipo Type</p>	 <p>Stadi Stages</p>	 <p>Capacità serbatoio Tank capacity</p>
 <p>Pompa tipo Pump</p>	 <p>Max pressione di lavoro Max working pressure</p>	 <p>Cilindrata Swept volume</p>
 <p>Aria aspirata Air displacement</p>	 <p>Motore Motor</p>	 <p>Cilindri Cylinders</p>
 <p>Aria resa Free air delivery</p>	 <p>Motore a scoppio Petrol engine</p>	 <p>Corsa Stroke</p>
 <p>Tensione Voltage</p>	 <p>Ø Volano Flywheel Ø</p>	 <p>Peso Weight</p>
 <p>g/min r.p.m.</p>	 <p>g/min - p.d.f. r.p.m. - p.d.f.</p>	 <p>Dimensioni (mm) Dimensions (mm)</p>
<p>A</p> <p>Intensità corrente Intensity of current</p>	 <p>Rumorosità Noise level</p> <p>dB(A)</p>	 <p>Minima potenza richiesta Min. required power</p>
 <p>Sega pneumatica Pneumatic chain saw</p>	 <p>Forbice pneumatica Pneumatic shear</p>	<p>Abbacchiatore pneumatico Pneumatic olive harvester</p> 

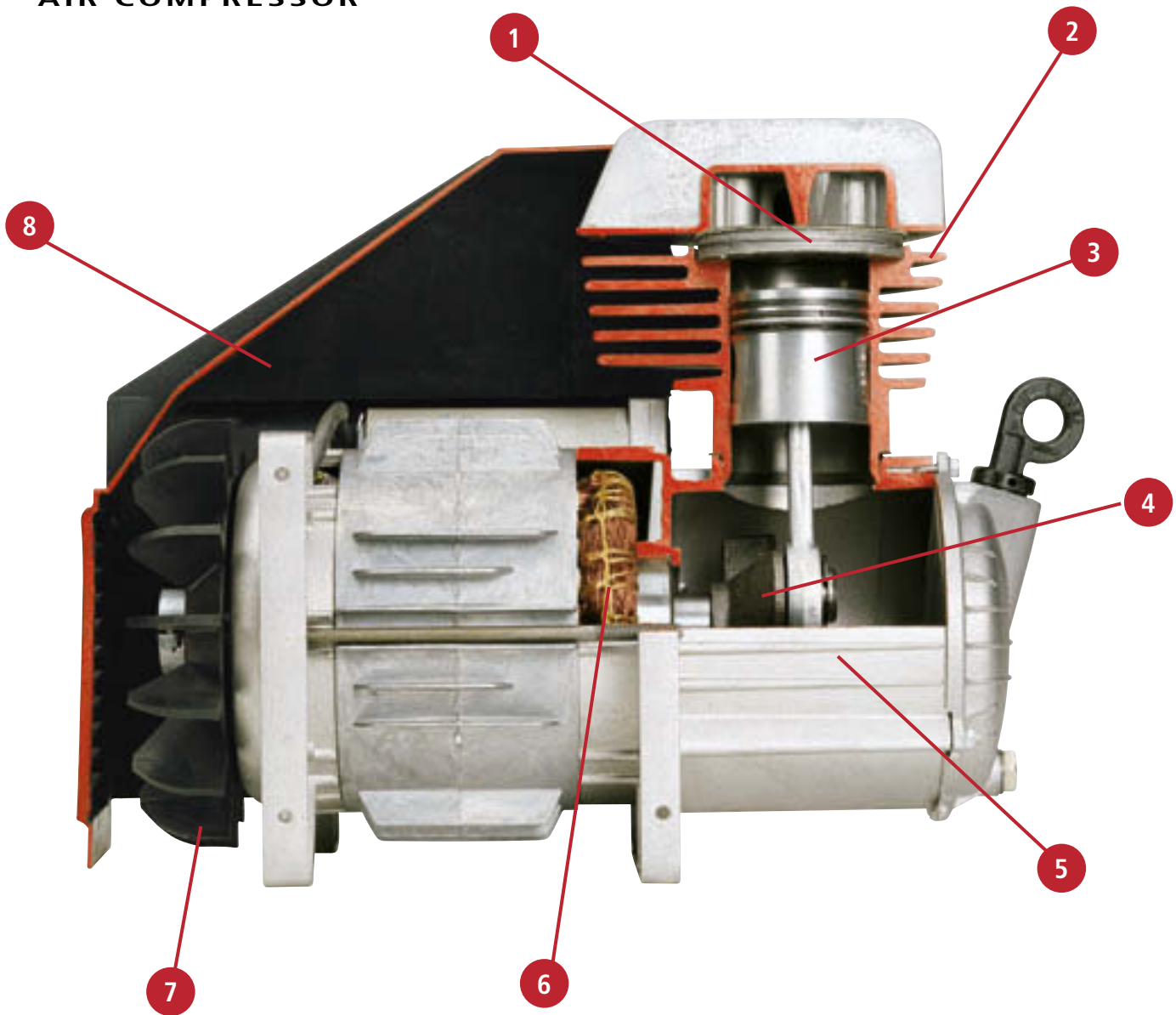

COMPRESSORE COASSIALE MONOCILINDRICO - SINGLE CYLINDER DIRECT DRIVEN COMPRESSOR -

Rif.	Descrizione + Description
1	Piattello portavalvole in acciaio Stainless steel valve plate
2	Cilindro in ghisa con ampie alettature Cast iron cylinder with ample fins
3	Pistone in alluminio Aluminium piston
4	Eccentrico in ghisa Cast iron eccentric

Rif.	Descrizione + Description
5	Corpo carter in alluminio Aluminium housing
6	Motore elettrico in carcassa con protezione termica Framed electric motor with thermal protection
7	Ventola di raffreddamento Cooling fan
8	Carentatura antiurto Shock-proof housing













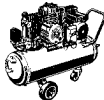



Compressori portatili

Serbatoio munito di piedini antivibranti, maniglia di trasporto, rubinetto scarico condensa, valvola di ritegno e 10 mt. di tubo con pistola aria. Dispositivi di controllo composti da: manometri, valvola sicurezza, riduttore di pressione con filtro, pressostato e 5 mt. cavo di alimentazione con spina.

Portable compressors

Tank provided with anti-vibration feet, carrying handle, condense drain cock, non return valve and 10 mt. hose complete with air gun.

The control device includes: pressure gauges, safety valve, pressure reducer with filter, pressure switch and 5 mt. electric cable with plug.

																				
Type	Lt.	Type	L/min.	m ³ /h	c.f.m.	kW	HP	Volt	Amp.	r.p.m.	n.	Stage n.	bar	p.s.i.	kg	L	B	H	LpA (R: 1m-H: 1m)	LwA
BRICO 110	2,5	CH110	115	6,9	4,1	0,75	1	230	4,7	1400	1	1	8	116	21	530	340	440	≤ 72	90
BRICO 210	2,5	CH210	220	13,2	7,6	1,5	2	230	8,2	2800	1	1	8	116	21	530	340	440	≤ 78	90















Compressore portatile

Serbatoio munito di piedini antivibranti, maniglia di trasporto, rubinetti scarico condensa, valvola di ritegno e valvola di sfiato. Dispositivi di controllo composti da: manometri, valvola sicurezza, riduttore di pressione con filtro, pressostato, cavo di alimentazione con spina e motoprotettore termico incorporato.

Portable compressor

Tank provided with anti-vibration feet, carrying handle, condense drain cocks, non return valve and release valve. -

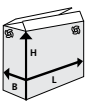
The control device includes: pressure gauges, safety valve, pressure reducer with filter, pressure switch, electric cable with plug and built-in thermal protector. -

																				
Type	Lt.	Type	L/min.	m ³ /h	c.f.m.	kW	HP	Volt	Amp.	r.p.m.	n.	Stage n.	bar	p.s.i.	kg	L	B	H	LpA (R.1m-H.1m)	LwA
PAC 2500	8+8	CH210	220	13,2	7,6	1,5	2	230	8,2	2800	1	1	8	116	30	550	370	520	≤ 78	90



Compressori carrellati monocilindrici

Compressori carrellati completi di maniglia e di ruote, per un facile spostamento. -

Funzionamento automatico comandato da pressostato e valvola di ritegno. -











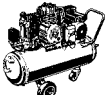

Dotati di strumenti di controllo: manometri, valvola di sicurezza, riduttore di pressione con rubinetto portagomma e valvola scarico condensa. -

Wheel mounted single cylinder compressors

Wheel mounted compressors provided with handle and wheels easy to be transported. -

Automatic operation controlled by a pressure switch and a non return valve. -

The control device include: pressure gauges, safety valve, pressure reducing valve with hose holder cock and condense drain valve. -

																				
Type	Lt.	Type	L/min.	m ³ /h	c.f.m.	kW	HP	Volt	Amp.	r.p.m.	n.	Stage n.	bar	p.s.i.	kg	L	B	H	LpA (R:1m-H:1m)	LwA
CH 10/110	10	CH110	115	6,9	4,1	0,75	1	230	4,7	1400	1	1	8	116	23	470	350	710	≤ 72	90
CH 10/210	10	CH210	220	13,2	7,6	1,5	2	230	8,2	2800	1	1	8	116	23	470	350	710	≤ 78	90



Compressori carrellati monocilindrici

Compressori carrellati completi di maniglia e di ruote, per un facile spostamento. -

Funzionamento automatico comandato da pressostato e valvola di ritegno. -











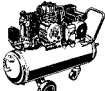

Dotati di strumenti di controllo: manometri, - valvola di sicurezza, riduttore di pressione con rubinetto portagomma e valvola scarico condensa. -

Wheel mounted single cylinder compressors

Wheel mounted compressors provided with handle and wheels easy to be transported. -

Automatic operation controlled by a pressure switch and a non return valve. -

The control device include: pressure gauges, - safety valve, pressure reducing valve with hose holder cock and condense drain valve. -

						A														
Type	Lt.	Type	L/min.	m ³ /h	c.f.m.	kW	HP	Volt	Amp.	r.p.m.	n.	Stage n.	bar	p.s.i.	kg	L	B	H	LpA (R.1m-H:1m)	LwA
CH 25/110	25	CH110	115	6,9	4,1	0,75	1	230	4,7	1400	1	1	8	116	26	660	330	610	≤ 72	90
CH 25/210	25	CH210	220	13,2	7,6	1,5	2	230	8,2	2800	1	1	8	116	26	660	330	610	≤ 78	90
CH 50/210	50	CH210	220	13,2	7,6	1,5	2	230	8,2	2800	1	1	8	116	38	1040	460	820	≤ 78	90

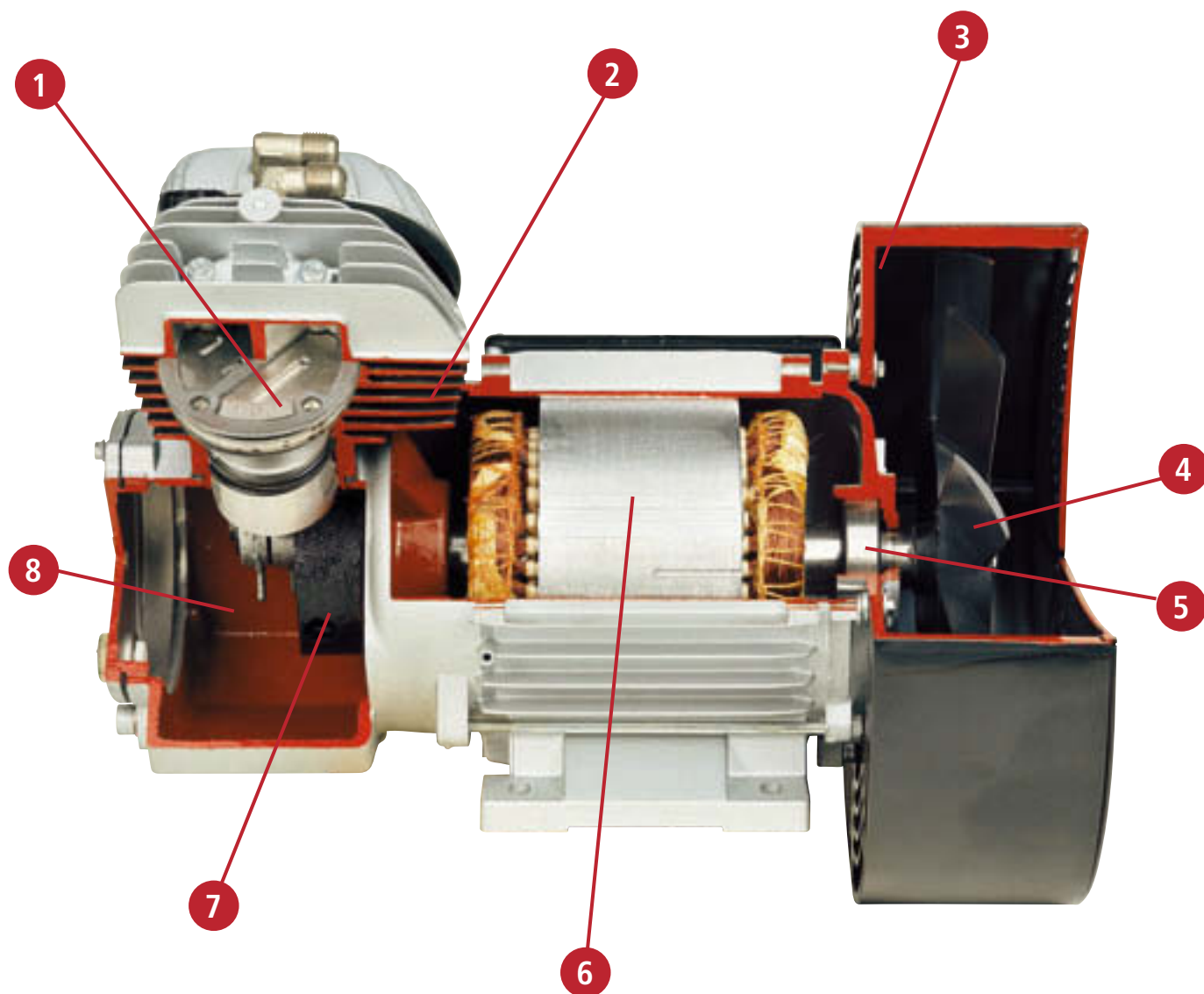

COMPRESSORE COASSIALE BICILINDRICO - TWO-CYLINDERS DIRECT DRIVEN COMPRESSOR -

Rif.	Descrizione + Description
1	Piattello portavalvole in acciaio Stainless steel valve plate
2	Cilindro in ghisa con ampie alettature Cast iron cylinder with ample fins
3	Copriventola Fan cover
4	Ventola di raffreddamento Cooling fan

Rif.	Descrizione + Description
5	Cuscinetto speciale di grande dimensione Special large size bearing
6	Motore elettrico in carcassa con protezione termica Framed electric motor with thermal protection
7	Eccentrico in ghisa Cast iron eccentric
8	Corpo carter in alluminio Aluminium housing



Compressore portatile bicilindrico













Compressore fornito sia di maniglia, che di ruote, particolarmente adatto ad un uso professionale. Funzionamento automatico comandato da pressostato.

Dotato di strumenti di controllo: manometri, valvola di sicurezza, riduttore di pressione con portagomma e valvola scarico condensa.

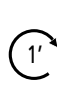
Two-cylinders portable compressor

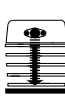
Portable compressor provided with handle and wheels, particularly suitable for a professional use. Automatic operation controlled by a pressure switch.

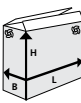
The control device includes: pressure gauges, safety valve, pressure reducing valve with hose holder cock and condense drain valve.

						A														
Type	Lt.	Type	L/min.	m ³ /h	c.f.m.	kW	HP	Volt	Amp.	r.p.m.	n.	Stage n.	bar	p.s.i.	kg	L	B	H	LpA (R.1m-H.1m)	LwA
CHB 20/230	25	CHB230	230	13,8	8	1,5	2	230	9,7	1400	2V	1	8	116	30	670	480	780	≤ 78	78



Compressori portatili bicilindrici











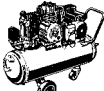

Compressori forniti sia di maniglia, che di ruote, -
particolarmente adatti ad un uso professionale. -
Funzionamento automatico comandato da -
pressostato. -

Dotati di strumenti di controllo: manometri, -
valvola di sicurezza, riduttore di pressione con -
portagomma e valvola scarico condensa. -





Two-cylinders portable compressors

Portable compressors provided with handle
and wheels, particularly suitable for a
professional use. Automatic operation
controlled by a pressure switch.

The control device includes: pressure gauges,
safety valve, pressure reducing valve with
hose holder cock and condense drain valve.

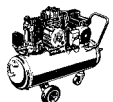
						A														
Type	Lt.	Type	L/min.	m ³ /h	c.f.m.	kW	HP	Volt	Amp.	r.p.m.	n.	Stage n.	bar	p.s.i.	kg	L	B	H	LpA (R:1m-H:1m)	LwA
CHB 25/230	25	CHB230	230	13,8	8	1,5	2	230	9,7	1400	2V	1	8	116	30	870	350	640	≤ 78	90
CHB 50/230	50	CHB230	230	13,8	8	1,5	2	230	9,7	1400	2V	1	8	116	44	1015	435	810	≤ 78	90
CHB 100/230	100	CHB230	230	13,8	8	1,5	2	230	9,7	1400	2V	1	10	145	53	1270	490	870	≤ 78	90



			
Type	n.	n.	n.
TT 22 MT 2011	1	2	-
TT 22 MT 3017	2	4	0-1

Compressori monostadio a cinghia

Testata bicilindrica in ghisa con valvole in acciaio inox. Motore elettrico monofase sovradimensionato a forte coppia di avviamento completo di protezione termica a riarmo manuale.











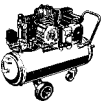

Gruppo dotato di maniglie e di due ruote, adatto a servizi in cantieri e luoghi accidentati.

Single-stage belt driven compressors

Two-cylinder cast iron head provided with stainless steel valves.

Single-phase oversized electric motor with high starting torque complete with thermal protection at manual reset.

Portable compressor provided with handles and two wheels, suitable for irregular working places.

						A							
Type	Lt.	Type	L/min. m ³ /h c.f.m.	kW HP	Volt	Amp.	r.p.m.	n.	Stage n.	bar p.s.i.	kg	L B H	LpA (R,Tn+H,1m) LwA
TT 22 MT 2011	11+11	K11	230 13,8 7,9	1,5 2	230	9	1000	2	1	10 145	55	880 690 880	≤ 72 97
TT 22 MT 3017	11+11	K17/C	410 24,6 14,1	2,2 3	230	12	1250	2	1	10 145	60	880 690 880	≤ 74 97



Compressori monostadio a cinghia

Testata cilindro in ghisa con valvole in acciaio inox ad elevato rendimento.

Funzionamento a basso regime di giri.

Motore elettrico monofase sovradimensionato a forte coppia di avviamento completo di protezione termica a riarmo manuale.











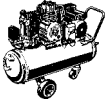

Il motore elettrico trifase è protetto da un interruttore magnetotermico.

Single-stage belt driven compressors

Cylinder cast iron head provided with stainless steel valves at high performance. Functioning at low r.p.m.

Single-phase oversized electric motor with high starting torque complete with thermal protection at manual reset.

The three-phase electric motor is protected by an overload switch.

						A														
Type	Lt.	Type	L/min.	m ³ /h	c.f.m.	kW	HP	Volt	Amp.	r.p.m.	n.	Stage n.	bar	p.s.i.	kg	L	B	H	LpA (R.1m-Hz:1m)	LwA
CRM 23	25	K11	220	13,2	7,77	1,1	1,5	230	6,5	850	2	1	10	145	44	870	380	710	≤ 74	90
CRM 24	25	K8	145	8,7	5,12	0,75	1	230	5,5	850	1	1	10	145	42	870	380	710	≤ 72	90
CR 23	25	K11	220	13,2	7,77	1,1	1,5	230/400	2,6	850	2	1	10	145	44	870	380	710	≤ 74	90
CR 24	25	K8	145	8,7	5,12	0,75	1	230/400	1,8	850	1	1	10	145	42	870	380	710	≤ 72	90



Compressori monostadio a cinghia

Testata cilindro in ghisa con valvole in acciaio inox ad elevato rendimento.

Funzionamento a basso regime di giri.

Motore elettrico monofase sovradimensionato a forte coppia di avviamento completo di protezione termica a riarmo manuale.

Il motore elettrico trifase è protetto da un interruttore magnetotermico.











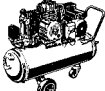

Single-stage belt driven compressors

Cylinder cast iron head provided with stainless-steel valves at high performance. -

Functioning at low r.p.m. -

Single-phase oversized electric motor with high-starting torque complete with thermal-protection at manual reset. -

The three-phase electric motor is protected by an overload switch. -

									A											
Type	Lt.	Type	L/min.	m ³ /h	c.f.m.	kW	HP	Volt	Amp.	r.p.m.	n.	Stage n.	bar	p.s.i.	kg	L	B	H	LpA (R:1m-H:1m)	LwA
CRM 50	50	K8	145	8,7	5,12	0,75	1	230	5,5	850	1	1	10	145	47	1040	460	820	≤ 72	90
CRM 51	50	K11	220	13,2	7,77	1,1	1,5	230	6,5	850	2	1	10	145	50	1040	460	820	≤ 74	90
CRM 52	50	K17	321	19,26	11,33	1,5	2	230	9	850	2	1	10	145	54	1040	460	820	≤ 72	90
CR 50	50	K8	145	8,7	5,12	0,75	1	230/400	1,8	850	1	1	10	145	47	1040	460	820	≤ 74	90
CR 51	50	K11	220	13,2	7,77	1,1	1,5	230/400	2,6	850	2	1	10	145	50	1040	460	820	≤ 72	90
CR 52	50	K17	321	19,26	11,33	1,5	2	230/400	3,5	850	2	1	10	145	54	1040	460	820	≤ 74	90



Compressori monostadio a cinghia











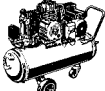

Testata bicilindrica in ghisa con valvole in acciaio inox ad elevato rendimento.

Funzionamento a basso regime di giri. Il motore elettrico monofase è sovradimensionato con forte coppia di avviamento completo di protezione termica a riarmo manuale. Il motore elettrico trifase è protetto da un interruttore magnetotermico.

Single-stage belt driven compressors

Two-cylinders cast iron head provided with stainless steel valves at high performance. - Functioning at low r.p.m. -

The single-phase electric motor is oversized with high starting torque complete with thermal protection at manual reset. - The three-phase electric motor is protected by an overload switch. -

									A											
Type	Lt.	Type	L/min.	m ³ /h	c.f.m.	kW	HP	Volt	Amp.	r.p.m.	n.	Stage n.	bar	p.s.i.	kg	L	B	H	LpA (R:1m-H:1m)	LwA
CRM 101	100	K11	220	13,2	7,77	1,1	1,5	230	6,5	850	2	1	10	145	64	1270	490	870	≤ 74	90
CRM 102	100	K17	321	19,26	11,33	1,5	2	230	9	850	2	1	10	145	69	1270	490	870	≤ 72	90
CRM 103	100	K18	385	23,1	13,6	2,2	3	230	12	850	2	1	10	145	73	1270	490	870	≤ 78	90
CR 101	100	K11	220	13,2	7,77	1,1	1,5	230/400	2,6	850	2	1	10	145	64	1270	490	870	≤ 74	90
CR 102	100	K17	321	19,26	11,33	1,5	2	230/400	3,5	850	2	1	10	145	69	1270	490	870	≤ 72	90
CR 103	100	K18	385	23,1	13,6	2,2	3	230/400	5	850	2	1	10	145	73	1270	490	870	≤ 78	90



Compressori monostadio a cinghia

Testata bicilindrica in ghisa con valvole in acciaio inox ad elevato rendimento.

Funzionamento a basso regime di giri.











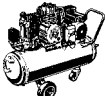



Il motore elettrico monofase è sovradimensionato con forte coppia di avviamento completo di protezione termica a riarmo manuale.

Il motore elettrico trifase è protetto da un interruttore magnetotermico.

Single-stage belt driven compressors

Two-cylinders cast iron head provided with stainless steel valves at high performance. - Functioning at low r.p.m. -

The single-phase electric motor is oversized with high starting torque complete with thermal protection at manual reset. - The three-phase electric motor is protected by an overload switch. -

																				
Type	Lt.	Type	L/min.	m ³ /h	c.f.m.	kW	HP	Volt	Amp.	r.p.m.	n.	Stage n.	bar	p.s.i.	kg	L	B	H	LpA (R:1m-H:1m)	LwA
CRM 152	150	K17	321	19,26	11,33	1,8	2,5	230	10	850	2	1	10	145	82	1490	510	920	≤ 72	90
CR 152	150	K17	321	19,26	11,33	1,8	2,5	230/400	4,3	850	2	1	10	145	82	1490	510	920	≤ 72	90



Compressori monostadio a cinghia











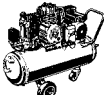



Testata bicilindrica in ghisa con valvole in acciaio inox ad elevato rendimento.

Funzionamento a basso regime di giri. Il motore elettrico monofase è sovradimensionato con forte coppia di avviamento completo di protezione termica a riarmo manuale. Il motore elettrico trifase è protetto da un interruttore magnetotermico.

Single-stage belt driven compressors

Two-cylinders cast iron head provided with stainless steel valves at high performance. -
Functioning at low r.p.m. -

The single-phase electric motor is oversized with high starting torque complete with thermal protection at manual reset. -
The three-phase electric motor is protected by an overload switch. -

																				
Type	Lt.	Type	L/min.	m ³ /h	c.f.m.	kW	HP	Volt	Amp.	r.p.m.	n.	Stage n.	bar	p.s.i.	kg	L	B	H	LpA (R:1m-H:1m)	LwA
CRM 203	200	K18	385	23,1	13,6	2,2	3	230	12	850	2	1	10	145	96	1580	530	990	≤ 78	90
CR 203	200	K18	385	23,1	13,6	2,2	3	230/400	5	850	2	1	10	145	96	1580	530	990	≤ 78	90















Compressori doppio stadio a cinghia

Testata bicilindrica e piastra portavalvole in ghisa, valvole lamellari in acciaio inox ad elevata resistenza. Il funzionamento a basso regime di giri ed un volano in ghisa sovradimensionato garantiscono un esercizio a bassa temperatura. Un ulteriore raffreddamento è garantito da collettori intermedi e finali con ampie alettature. Il motore elettrico trifase è comandato da un teleruttore con protezione magnetotermica.

Two-stage belt driven compressors

Two-cylinders cast iron head provided with cast iron valve plate and stainless steel valves at high resistance. The functioning at low r.p.m. and a cast iron oversized fly wheel permit a low working temperature. Intermediate and ending collectors with ample fins allow a further cooling.

The three-phase electric motor is controlled by a contactor with thermic protection.

						A							
Type	Lt.	Type	L/min. m ³ /h c.f.m.	kW HP	Volt	Amp.	r.p.m.	n.	Stage n.	bar p.s.i.	kg	L B H	LpA (R.1m-H:1m) LwA
CRM 303	270	K18	385 23,1 13,6	2,2 3	230	12	850	2	1	10 145	125	1700 720 1150	≤ 78 90
CR 303	270	K18	385 23,1 13,6	2,2 3	230/400	5	850	2	1	10 145	125	1700 720 1150	≤ 78 90
CR 304	270	K28	460 27,6 16,3	3 4	230/400	6,7	900	2	2	10 145	153	1700 720 1150	≤ 76 99
CR 305	270	K30	727 43,62 25,7	4 5,5	230/400	8,6	850	2	2	10 145	170	1700 720 1150	≤ 76 99













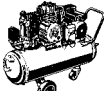

Compressori doppio stadio a cinghia

Testata bicilindrica e piastra portavalvole in ghisa, valvole lamellari in acciaio inox ad elevata resistenza. Il funzionamento a basso regime di giri ed un volano in ghisa sovradimensionato garantiscono un esercizio a bassa temperatura. Un ulteriore raffreddamento è garantito da collettori intermedi e finali con ampie alettature. Il motore elettrico trifase è comandato da un teleruttore con protezione magnetotermica.

Two-stage belt driven compressors

Two-cylinders cast iron head provided with cast iron valve plate and stainless steel valves at high resistance. The functioning at low r.p.m. and a cast iron oversized fly wheel permit a low working temperature. Intermediate and ending collectors with ample fins allow a further cooling.

The three-phase electric motor is controlled by a contactor with thermic protection.

						A														
Type	Lt.	Type	L/min.	m ³ /h	c.f.m.	kW	HP	Volt	Amp.	r.p.m.	n.	Stage n.	bar	p.s.i.	kg	L	B	H	LpA (R:1m-H:1m)	LwA
CR 505	500	K30	727	43,62	25,7	4	5,5	230/400	8,6	850	2	2	10	145	200	2130	740	1350	≤ 76	99
CR 507	500	K50	1074	64,44	37,9	5,5	7,5	230/400	11,4	850	2	2	10	145	235	2130	740	1430	≤ 81	99
CR 510	500	K60	1454	82,24	51,3	7,5	10	230/400	14,8	850	4	2	10	145	280	2130	740	1430	≤ 81	99

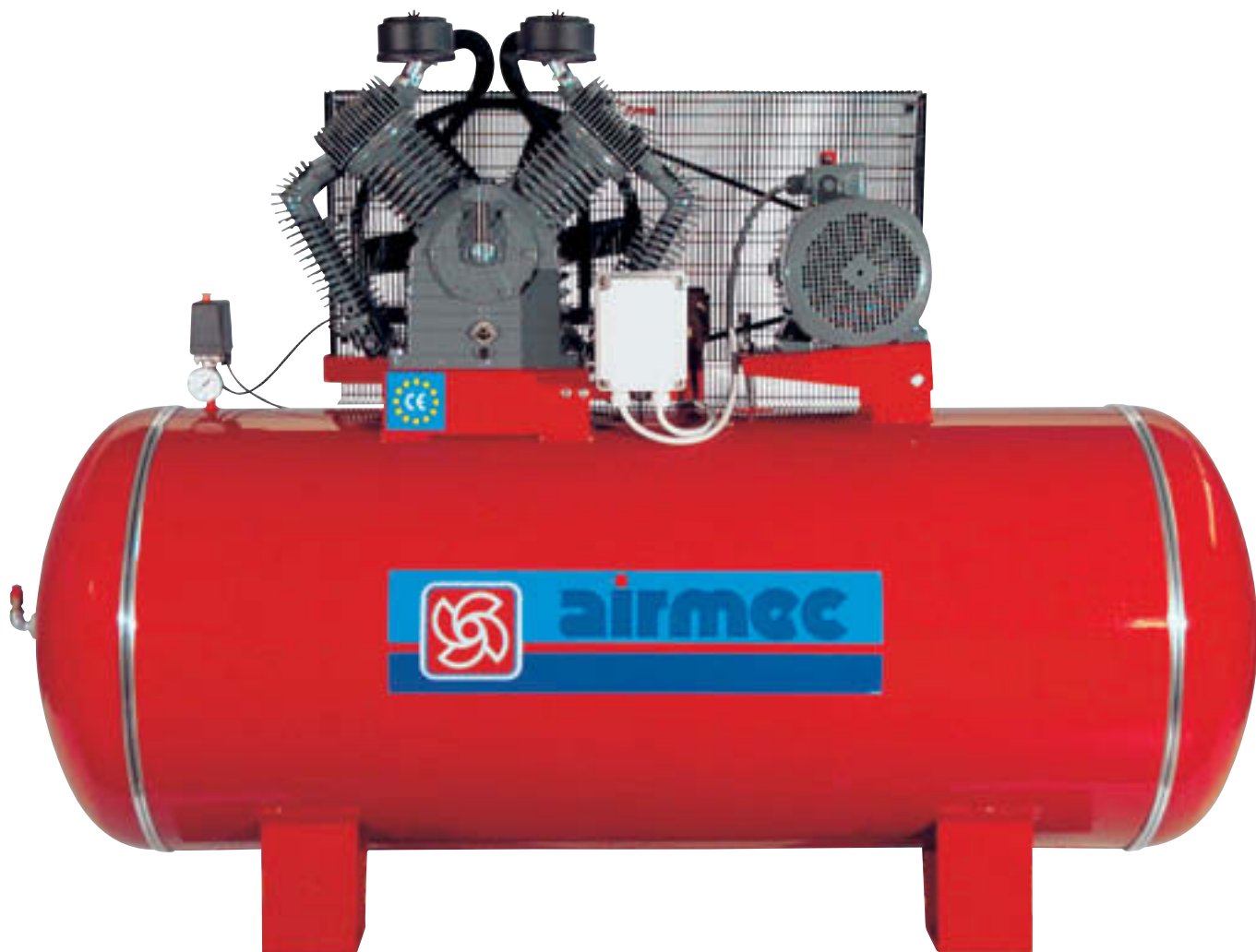

Compressore doppio stadio a cinghia













Doppia testata bicilindrica a V in ghisa, valvole lamellari in acciaio inox ad elevata resistenza. Albero in ghisa sferoidale.

Il funzionamento a basso regime di giri ed un volano in ghisa con ampie pale garantiscono un funzionamento a bassa temperatura. Un ulteriore raffreddamento è garantito dai collettori intermedi e di uscita dell'aria dotati di ampie alettature. Il motore elettrico trifase è comandato da un teleruttore con protezione magnetotermica.

Two-stage belt driven compressor

Two-cylinders V double cast iron head provided with stainless steel valves at high resistance. Spherical cast iron shaft. The functioning at low r.p.m. and a cast iron oversized fly wheel permit a low working temperature. Intermediate and ending collectors with ample fins allow a further cooling.

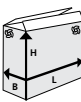
The three-phase electric motor is controlled by a contactor with thermic protection.

						A							
Type	Lt.	Type	L/min. m ³ /h c.f.m.	kW HP	Volt	Amp.	r.p.m.	n.	Stage n.	bar p.s.i.	kg	L B H	LpA (R.1m-H.1m) LwA
CF 1010	1000	K60	1454 82,24 51,3	7,5 10	230/400	14,8	850	4	2	10 145	400	2350 900 1750	≤ 81 99



Compressori TANDEM

Compressori industriali dotati di due testate e due motori.

Gruppi pompanti bicilindrici con cilindro in ghisa bistadio.

Il funzionamento a basso regime di giri garantisce basse temperature e una durata maggiore.

I motori sono comandati da una apparecchiatura elettrica dotata di tutte le protezioni per evitare inconvenienti.

TANDEM compressors

Industrial compressors provided with two heads and two motors.

Two-cylinders pumping groups with cast iron two-stage cylinder.

The functioning at low r.p.m. permit a low temperature and longer life.

The motors are controlled by an electrical system with all the necessary protections to avoid inconveniences.

Type	Lt.	Type	L/min.	m ³ /h	c.f.m.	kW	HP	Volt	Amp.	r.p.m.	n.	Stage n.	bar	p.s.i.	kg	L	B	H	LpA (R:1m-H:1m)	LwA
CR 544	500	K28+K28	460x2	27,6x2	16,3x2	3+3	4+4	230/400	6,7+6,7	900	2+2	2	10	145	310	2130	740	1350	≤ 80	99
CR 555	500	K30+K30	727x2	43,62x2	25,7x2	4+4	5,5+5,5	230/400	8,6+8,6	850	2+2	2	10	145	350	2130	740	1350	≤ 80	99

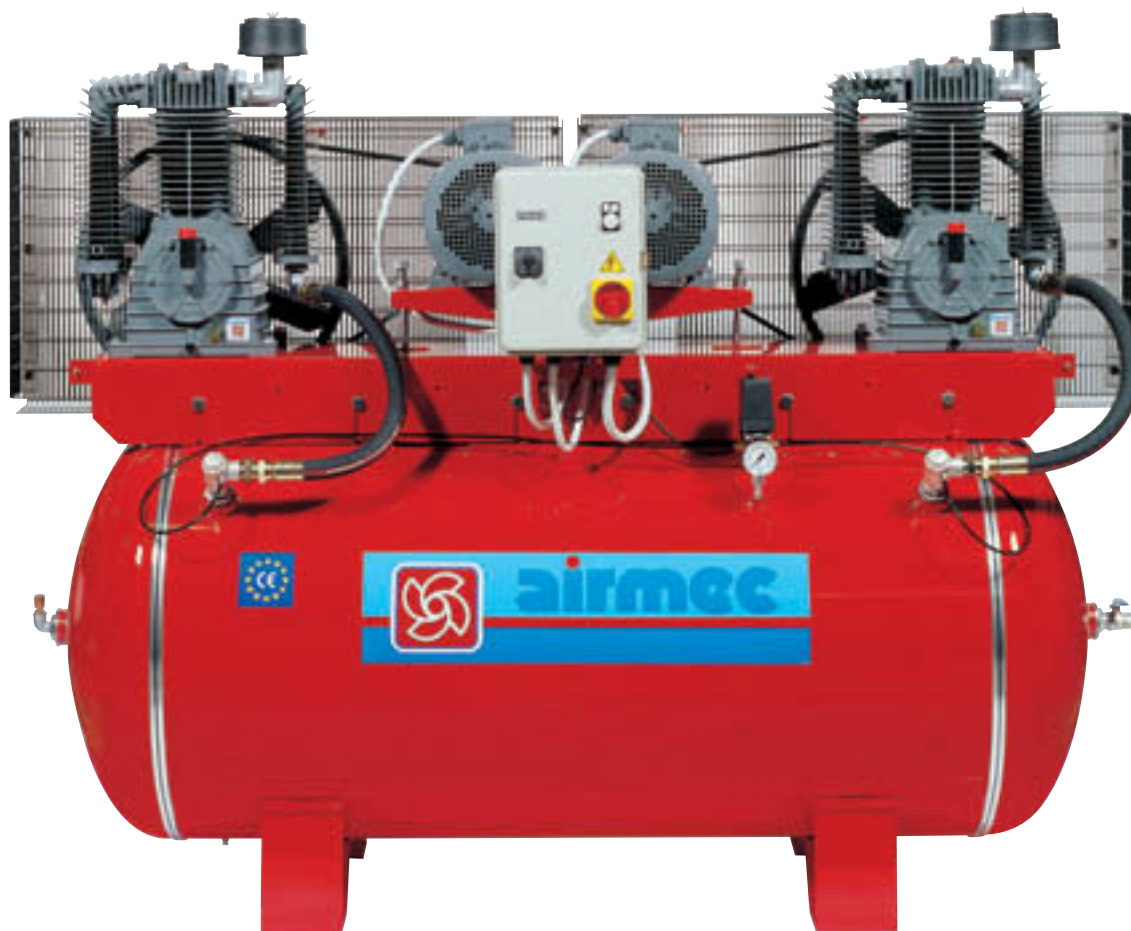

Compressori TANDEM

Compressori industriali dotati di due testate e due motori. Gruppi pompanti bicilindrici con cilindro in ghisa bistadio.

Il funzionamento a basso regime di giri garantisce basse temperature e una durata maggiore. I motori sono comandati da una apparecchiatura elettrica dotata di tutte le protezioni per evitare inconvenienti.

TANDEM compressors

Industrial compressors provided with two heads and two motors. Two-cylinders pumping groups with cast iron two-stage cylinder.

The functioning at low r.p.m. permit a low temperature and longer life.

The motors are controlled by an electrical system with all the necessary protections to avoid inconveniences.

Type	Lt.	Type	L/min.	m ³ /h	c.f.m.	kW	HP	Volt	Amp.	r.p.m.	n.	Stage n.	bar	p.s.i.	kg	L	B	H	LpA (R:1m-H:1m)	LwA
CF 977	900	K50+K50	1074 x2	64,44 x2	37,9 x2	5,5+5,5	7,5+7,5	230/400	11,4+11,4	850	2+2	2	10	145	510	2650	900	1750	≤ 84	99
CF 911	900	K60+K60	1454 x2	82,24 x2	51,3 x2	7,5+7,5	10+10	230/400	14,8+14,8	850	4+4	2	10	145	530	2650	900	1750	≤ 84	99



Compressori TANDEM

Compressori industriali dotati di due testate e due motori.

Gruppi pompanti bicilindrici con cilindro in ghisa bistadio.

Il funzionamento a basso regime di giri garantisce basse temperature e una durata maggiore. I motori sono comandati da una apparecchiatura elettrica dotata di tutte le protezioni per evitare inconvenienti.

TANDEM compressors

Industrial compressors provided with two heads and two motors.

Two-cylinders pumping groups with cast iron two-stage cylinder.

The functioning at low r.p.m. permit a low temperature and longer life.

The motors are controlled by an electrical system with all the necessary protections to avoid inconveniences.

Type	Lt.	Type	L/min.	m ³ /h	c.f.m.	kW	HP	Volt	Amp.	r.p.m.	n.	Stage n.	bar	p.s.i.	kg	L	B	H	LpA (R:1m-H:1m)	LwA
CF 1077	1000	K50+K50	1074 x2	64,44 x2	37,9 x2	5,5+5,5	7,5+7,5	230/400	11,4+11,4	850	2+2	2	10	145	480	2650	900	1750	≤ 84	99
CF 1110	1000	K60+K60	1454 x2	82,24 x2	51,3 x2	7,5+7,5	10+10	230/400	14,8+14,8	850	4+4	2	10	145	530	2650	900	1750	≤ 84	99

Compressori verticali monostadio a cinghia

Testata bicilindrica in ghisa con valvole in acciaio inox ad elevato rendimento. Funzionamento a basso regime di giri. La costruzione su serbatoio verticale ed il conseguente minimo ingombro ne permettono l'utilizzo anche in spazi ristretti. Il motore elettrico monofase è sovradimensionato con forte coppia di avviamento completo di protezione termica a riarmo manuale.

Il motore elettrico trifase è protetto da un interruttore magnetotermico regolabile installato direttamente sul pressostato.











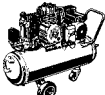



Single-stage belt driven vertical compressors

Two-cylinders cast iron head provided with stainless steel valves at high performance. Functioning at low r.p.m. The construction on the vertical tank and the consequent reduced overall dimension make it also suitable for use in restricted space.

The single-phase electric motor is oversized with high starting torque complete with thermal protection at manual reset.

The three-phase electric motor is protected by an adjustable magnetothermal circuit breaker on the pressure switch.



																				
Type	Lt.	Type	L/min.	m ³ /h	c.f.m.	kW	HP	Volt	Amp.	r.p.m.	n.	Stage n.	bar	p.s.i.	kg	L	B	H	LpA (R:1m-H:1m)	LwA
CFMV 102	100	K17	321	19,26	11,33	1,5	2	230	9	850	2	1	10	145	70	685	685	1490	≤ 72	90
CFV 102	100	K17	321	19,26	11,33	1,5	2	230/400	3,5	850	2	1	10	145	70	685	685	1490	≤ 72	90

Compressori verticali monostadio a cinghia











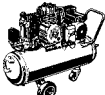



Testata bicilindrica in ghisa con valvole in acciaio inox ad elevato rendimento. Funzionamento a basso regime di giri. La costruzione su serbatoio verticale ed il conseguente minimo ingombro ne permettono l'utilizzo anche in spazi ristretti. Il motore elettrico monofase è sovradimensionato con forte coppia di avviamento completo di protezione termica a riarmo manuale.

Il motore elettrico trifase è protetto da un interruttore magnetotermico regolabile installato direttamente sul pressostato.

Single-stage belt driven vertical compressors

Two-cylinders cast iron head provided with stainless steel valves at high performance. Functioning at low r.p.m. The construction on the vertical tank and the consequent reduced overall dimension make it also suitable for use in restricted space. The single-phase electric motor is oversized with high starting torque complete with thermal protection at manual reset. The three-phase electric motor is protected by an adjustable magnetothermal circuit breaker on the pressure switch.



																				
Type	Lt.	Type	L/min.	m ³ /h	c.f.m.	kW	HP	Volt	Amp.	r.p.m.	n.	Stage n.	bar	p.s.i.	kg	L	B	H	LpA (R:1m-H:1m)	LwA
CFMV 203	200	K18	385	23,1	13,6	2,2	3	230	12	850	2	1	10	145	112	685	685	1600	≤ 78	90
CFV 203	200	K18	385	23,1	13,6	2,2	3	230/400	5	850	2	1	10	145	112	685	685	1600	≤ 78	90













Compressori verticali bistadio a cinghia

Testata bicilindrica e piastre portavalvole in ghisa, valvole lamellari in acciaio inox ad elevata resistenza. Il funzionamento a basso regime di giri ed un volano in ghisa sovradimensionato garantiscono n esercizio a bassa temperatura. Un ulteriore raffreddamento è garantito da collettori intermedi e finali con ampie alettature. La costruzione su serbatoio verticale ed il conseguente minimo ingombro ne permettono l'utilizzo anche in spazi ristretti. Il motore elettrico trifase è protetto da un interruttore magnetotermico regolabile installato direttamente sul pressostato.

Two-stage belt driven vertical compressors

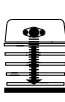
Two-cylinders cast iron head provided with cast iron valve plate and stainless steel valves at high resistance. The functioning at low r.p.m. and a cast iron oversized fly wheel permit a low working temperature. Intermediate and ending collectors with ample fins allow a further cooling. The construction on the vertical tank and the consequent reduced overall dimension make it also suitable for use in restricted spaces. The three-phase electric motor is protected by an adjustable magnetothermal circuit breaker on the pressure switch.

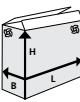

																				
Type	Lt.	Type	L/min.	m ³ /h	c.f.m.	kW	HP	Volt	Amp.	r.p.m.	n.	Stage n.	bar	p.s.i.	kg	L	B	H	LpA (R.1m-H:1m)	LwA
CFMV 303	270	K18	385	23,1	13,6	2,2	3	230	12	850	2	1	10	145	118	685	685	1700	≤ 78	90
CFV 303	270	K18	385	23,1	13,6	2,2	3	230/400	5	850	2	1	10	145	118	685	685	1700	≤ 78	90
CFV 304	270	K28	460	27,6	16,3	3	4	230/400	6,7	900	2	1	10	145	155	685	860	1850	≤ 76	99
CFV 305	270	K30	727	43,62	25,7	4	5,5	230/400	8,6	850	2	1	10	145	164	685	860	1920	≤ 76	99













Motocompressore

Motocompressore estremamente compatto e leggero dove il telaio funge anche da serbatoio. Dotato di piedini antivibranti, valvola automatica di messa a vuoto, lubrificatore, manometro e rubinetto rapido.

Petrol engine air compressors





Extremely compact and light motorized compressor, where the frame serves also as a tank. It is complete of anti-vibration feet, automatic vacuum valve, oilier, glycerine pressure gauge, rapid faucet.

																	
Type	Lt.	Type	L/min.	m ³ /h	c.f.m.	HP	r.p.m.	n.	Stage n.	bar	p.s.i.	kg	L	B	H	LpA (R.1m-H:1m)	LwA
MICRO 02/260	2	S15	260	15,6	9,1	4	3500	1	1	8	116	26	510	300	500	96	97

CRS 1040/260

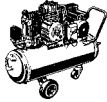
CRS 1055/430



			
Type	n.	n.	n.
CRS 1040/260	1	2	-
CRS 1055/430	2	4	0-1













✓ **KIT ACCELERATORE A RICHIESTA**
SELF THROTTLE KIT UNDER REQUEST

Motocompressore

Motocompressore con motore a scoppio a benzina 4 tempi. Avviamento a strappo con fune autoavvolgente. La maniglia pieghevole lo rende estremamente compatto e adatto al trasporto. Un telaio pratico e maneggevole dotato di ruote pneumatiche facilita gli spostamenti anche su terreni accidentati. Testata bicilindrica monostadio. V alvola automatica di sfiato e messa a vuoto che mantiene la pressione costante nel serbatoio. Completo di filtro-riduttore-lubrificatore e due rubinetti rapidi universali.

Petrol engine air compressors

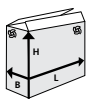
Motor compressor with 4-stroke petrol engine. Self rewinding rope starter. A folding handle makes it extremely compact and suitable to carry. A practical and handy frame with pneumatic wheels allows easy transportation even on irregular routes. Single-stage two-cylinders compressor heads. Automatic release valve and vacuum setting which maintains a constant pressure in the tank. Complete with filter-reducer-lubricator and two universal rapid cock.

																	
Type	Lt.	Type	L/min.	m ³ /h	c.f.m.	HP	r.p.m.	n.	Stage n.	bar	p.s.i.	kg	L	B	H	LpA (Rc-Tm-H-Tm)	LwA
CRS 1040/260	10	K12	260	15,6	8,88	4	1150	2	1	11	160	52	880	690	880	≤ 94	97
CRS 1055/430	10	K17/C	430	25,8	14,69	5,5	1250	2	1	11	160	58	880	690	880	≤ 94	97

TTS 2255

TTS 2265



**KIT ACCELERATORE A RICHIESTA
SELF THROTTLE KIT UNDER REQUEST**

Type	n.	n.	n.
TTS 2255/450	2	4	0-1
TTS 2265/520	2	5	1

Motocompressore

Motocompressore ad alte prestazioni con motore a scoppio a benzina 4 tempi. Avviamento a strappo con fune autoavvolgente. Testata bicilindrica monostadio con cilindro in ghisa ad elevato rendimento d'aria. Valvola automatica di sfiato e messa a vuoto che mantiene la pressione costante nel serbatoio. Completo di filtro-riduttore-lubrificatore e ripartitore con attacchi multipli. Un telaio pratico e maneggevole dotato di ruote pneumatiche lo rende adatto per l'utilizzo in agricoltura.

Petrol engine air compressors

High-performance motor compressor with 4-stroke petrol engine. Self rewinding rope starter. Single-stage two-cylinders compressor heads with cast iron cylinder at high performance air delivery. Automatic release valve and vacuum setting which maintains a constant pressure in the tank. Complete with filter-reducer-lubricator and distribution manifold. Provided with pneumatic wheels and handy frame, suitable for agricultural use.

Type	Lt.	Type	L/min.	m ³ /h	c.f.m.	HP	r.p.m.	n.	Stage n.	bar	p.s.i.	kg	L	B	H	LpA (R-Tr-H-Tm)	LwA
TTS 2255/450	11+11	K17/C	450	27,1	15,5	5,5	1300	2	1	11	160	65	880	690	880	≤ 95	97
TTS 2265/520	11+11	K18/C	520	31,2	18,36	6,5	1300	2	1	11	160	68	880	690	880	≤ 95	97



✓ **KIT ACCELERATORE A RICHIESTA
SELF THROTTLE KIT UNDER REQUEST**

Type	n.	n.	n.
TTS 3465/520	2	5	1

Motocompressore





Motocompressore ad alte prestazioni con motore a scoppio a benzina 4 tempi. Avviamento a strappo con fune autoavvolgente. Testata bicilindrica monostadio con cilindro in ghisa ad elevato rendimento d'aria. Valvola automatica di sfiato e messa a vuoto che mantiene la pressione costante nel serbatoio. Completo di filtro-riduttore-lubrificatore e ripartitore con attacchi multipli. Un telaio pratico e maneggevole dotato di ruote pneumatiche lo rende adatto per l'utilizzo in agricoltura.

Petrol engine air compressors

High-performance motor compressor with 4-stroke petrol engine. Self rewinding rope starter. Single-stage two-cylinders compressor heads with cast iron cylinder at high performance air delivery. Automatic release valve and vacuum setting which maintains a constant pressure in the tank. Complete with filter-reducer-lubricator and distribution manifold. Provided with pneumatic wheels and handy frame, suitable for agricultural use.

Type	Lt.	Type	L/min.	m ³ /h	c.f.m.	HP	r.p.m.	n.	Stage n.	bar	p.s.i.	kg	L	B	H	LpA (R:1m-H:1m)	LwA
TTS 3465/520	17+17	K18/C	520	31,2	18,36	6,5	1300	2	1	11	160	75	1170	770	900	≤ 95	97















			
Type	n.	n.	n.
TTS 3490/610	3	7	1-2

Motocompressore





Motocompressore altamente professionale con motore a scoppio benzina 4 tempi. Avviamento elettrico con batteria. L'installazione di serie del kit acceleratore e della puleggia centrifuga permette la disconnessione automatica della testata in mancanza di richiesta d'aria, riducendo consumi ed usura. Completo di valvola automatica di messa a vuoto, batteria, filtro-riduttore-lubrificatore, ripartitore con attacchi multipli. Gruppo dotato di maniglie smontabili e ruote pneumatiche, adatto per l'utilizzo in agricoltura.

Petrol engine air compressors

Professional air compressor with 4-stroke petrol engine. Electric start with battery. The serial installation of self throttle kit and of centrifugal pulley allows automatic disconnection of the head in lack of air request reducing consumption and wear. Complete with automatic vacuum valve, battery, filter-reducer-lubricator, distribution manifold. Provided with removable handles and pneumatic wheels, suitable for agricultural use.

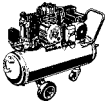
											
Type	Lt.	Type	L/min. m ³ /h c.f.m.	HP	r.p.m.	n.	Stage n.	bar p.s.i.	kg	L B H	LpA (R:1m-H:1m) LwA
TTS 3490/610	17+17	K28	610 36,61 21,53	9	1300	2	2	11 160	118	1170 770 1020	≤ 96 97















			
Type	n.	n.	n.
TTS 34110/900	4	10	2

Motocompressore





Motocompressore altamente professionale con motore a scoppio benzina 4 tempi. Avviamento elettrico con batteria. L'installazione di serie del kit acceleratore e della puleggia centrifuga permette la disconnessione automatica della testata in mancanza di richiesta d'aria, riducendo consumi ed usura. Completo di valvola automatica di messa a vuoto, batteria, filtro-riduttore-lubrificatore, ripartitore con attacchi multipli. Gruppo dotato di maniglie smontabili e ruote pneumatiche, adatto per l'utilizzo in agricoltura.

Petrol engine air compressors

Professional air compressor with 4-stroke petrol engine. Electric start with battery. The serial installation of self throttle kit and of centrifugal pulley allows automatic disconnection of the head in lack of air request reducing consumption and wear. Complete with automatic vacuum valve, battery, filter-reducer-lubricator, distribution manifold. Provided with removable handles and pneumatic wheels, suitable for agricultural use.

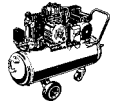
																	
Type	Lt.	Type	L/min.	m ³ /h	c.f.m.	HP	r.p.m.	n.	Stage n.	bar	p.s.i.	kg	L	B	H	LpA (R:1m-H:1m)	LwA
TTS 34110/900	17+17	K30	900	54,02	31,77	11	1250	2	2	11	160	140	1170	770	1020	≤ 96	97











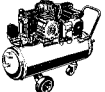

			
Type	n.	n.	n.
CRD 1042/450	2	4	0-1

Motocompressore diesel





Motocompressore con motore a scoppio diesel 4 tempi. Avviamento a strappo con fune autoavvolgente. La maniglia pieghevole lo rende estremamente compatto e adatto al trasporto. Un telaio pratico e maneggevole dotato di ruote pneumatiche facilita gli spostamenti anche su terreni accidentati. Testata bicilindrica monostadio con cilindro in ghisa. Valvola automatica di sfiato e messa a vuoto che mantiene la pressione costante nel serbatoio. Completo di filtro-riduttore-lubrificatore e due rubinetti rapidi universali.

Diesel engine air compressors

Motor compressor with 4-stroke diesel engine. Self rewinding rope starter. A folding handle makes it extremely compact and suitable to carry. A practical and handy frame with pneumatic wheels allows easy transportation even on irregular routes. Single-stage two-cylinders compressor heads with cast iron cylinder. Automatic release valve and vacuum setting which maintains a constant pressure in the tank. Complete with filter-reducer-lubricator and two universal rapid cock.

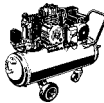
																	
Type	Lt.	Type	L/min.	m ³ /h	c.f.m.	HP	r.p.m.	n.	Stage n.	bar	p.s.i.	kg	L	B	H	LpA (R:1m-H:1m)	LwA
CRD 1042/450	10	K 17/C	450	27,1	15,9	4,2	1300	2	1	11	160	64	880	690	880	≤ 96	97













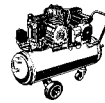

			
Type	n.	n.	n.
TTD 2242/520	2	5	1

Motocompressore diesel





Motocompressore altamente professionale con motore a scoppio diesel 4 tempi. Avviamento a strappo con fune autoavvolgente. L'installazione di serie del kit acceleratore e della puleggia centrifuga permette la disconnessione automatica della testata in mancanza di richiesta d'aria, riducendo consumi ed usura. Completo di valvola automatica di messa a vuoto, batteria, filtro-riduttore-lubrificatore, ripartitore con attacchi multipli. Gruppo dotato di maniglie smontabili e ruote pneumatiche, adatto per l'utilizzo in agricoltura.

Diesel engine air compressors

Professional air compressor with 4-stroke diesel engine. Self rewinding rope starter. The serial installation of self throttle kit and of centrifugal pulley allows automatic disconnection of the head in lack of air request reducing consumption and wear. Complete with automatic vacuum valve, battery, filter-reducer-lubricator, distribution manifold. Provided with removable handles and pneumatic wheels, suitable for agricultural use.

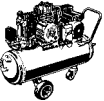
																	
Type	Lt.	Type	L/min.	m ³ /h	c.f.m.	HP	r.p.m.	n.	Stage n.	bar	p.s.i.	kg	L	B	H	LpA (R:1m-H:1m)	LwA
TTD 2242/520	11+11	K18/C	520	31,2	18,36	4,2	1300	2	1	11	160	70	880	690	880	≤ 95	97
TTD 2242/520 AVE	11+11	K18/C	520	31,2	18,36	4,2	1300	2	1	11	160	70	880	690	880	≤ 95	97













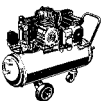

			
Type	n.	n.	n.
TTD 3460/610	3	7	1 - 2

Motocompressore diesel





Motocompressore altamente professionale con motore a scoppio diesel 4 tempi. Avviamento elettrico con batteria. L'installazione di serie del kit acceleratore e della puleggia centrifuga permette la disconnessione automatica della testata in mancanza di richiesta d'aria, riducendo consumi ed usura. Completo di valvola automatica di messa a vuoto, batteria, filtro-riduttore-lubrificatore, ripartitore con attacchi multipli. Gruppo dotato di maniglie smontabili e ruote pneumatiche, adatto per l'utilizzo in agricoltura.

Diesel engine air compressors

Professional air compressor with 4-stroke diesel engine. Electric start with battery. The serial installation of self throttle kit and of centrifugal pulley allows automatic disconnection of the head in lack of air request reducing consumption and wear. Complete with automatic vacuum valve, battery, filter-reducer-lubricator, distribution manifold. Provided with removable handles and pneumatic wheels, suitable for agricultural use.

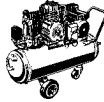
																	
Type	Lt.	Type	L/min.	m ³ /h	c.f.m.	HP	r.p.m.	n.	Stage n.	bar	p.s.i.	kg	L	B	H	LpA (Rc:1m-H:1m)	LwA
TTD 3460/610	17+17	K28	610	36,61	21,53	6	1300	2	2	11	160	139	1170	770	1020	≤ 96	97



			
Type	n.	n.	n.
TTD 3496/900	4	10	2

Motocompressore diesel











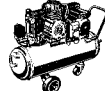

Motocompressore altamente professionale con motore a scoppio diesel 4 tempi. Avviamento elettrico con batteria. L'installazione di serie del kit acceleratore e della puleggia centrifuga permette la disconnessione automatica della testata in mancanza di richiesta d'aria, riducendo consumi ed usura. Completo di valvola automatica di messa a vuoto, batteria, filtro-riduttore-lubrificatore, ripartitore con attacchi multipli. Gruppo dotato di maniglie smontabili e ruote pneumatiche, adatto per l'utilizzo in agricoltura.

Diesel engine air compressors

Professional air compressor with 4-stroke diesel engine.

Electric start with battery.

The serial installation of self throttle kit and of centrifugal pulley allows automatic disconnection of the head in lack of air request reducing consumption and wear. Complete with automatic vacuum valve, battery, filter-reducer-lubricator, distribution manifold. Provided with removable handles and pneumatic wheels, suitable for agricultural use.

																	
Type	Lt.	Type	L/min.	m ³ /h	c.f.m.	HP	r.p.m.	n.	Stage n.	bar	p.s.i.	kg	L	B	H	LpA (Rc1m-H:1m)	LwA
TTD 3496/900	17+17	K30	900	54,02	31,77	9,6	1250	2	2	11	160	165	1170	770	1020	≤ 96	97

KIT EASY 260



Type	n.	n.	n.
KIT EASY 260	1	2	-

Kit Easy 260

Kit completo per una postazione di lavoro, - ideale per la raccolta - e la potatura di frutteti, vigneti, oliveti di piccole dimensioni. -

- 1 Motocompressore CRS 1040/260 con motore benzina 4 Hp.
 - 1 Abbacchiatore pneumatico.
 - 1 Forbice pneumatica.
 - 1 Asta telescopica alluminio 1,25 - 1,95 mt.
 - 1 Tubo poliuretano 8x10 - 20 mt. con rubinetti.
- Kit acceleratore di serie

Kit Easy 260





Complete kit for one working position, suitable for harvesting and pruning of orchards, vineyards, olive-groves of small area dimensions.

- 1 Motocompressore CRS 1040/260 with petrol engine 4 Hp.
 - 1 Pneumatic harvester.
 - 1 Pneumatic shear.
 - 1 Telescopic extension poles 1,25 - 1,95 mt.
 - 1 Polyurethane hose 8x10 - 20 mt. with rapid connection.
- Self throttle kit included

Type	Lt.	Type	L/min.	m ³ /h	c.f.m.	HP	r.p.m.	n.	Stage n.	bar	p.s.i.	kg	L	B	H	LpA (Rc,1m-H,1m)	LwA
KIT EASY 260	10	K 12	260	15,6	8,88	4	1150	2	1	11	160	57	880	690	880	≤ 94	97

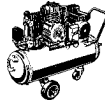
KIT EASY 430



			
Type	n.	n.	n.
KIT EASY 430	2	4	0-1

Kiy Easy 430













Kit completo per 2 postazioni di lavoro, ideale per la raccolta e la potatura di frutteti, vigneti, oliveti di piccole dimensioni.

- 1 Motocompressore CRS 1055/430 con motore benzina 5,5 Hp.
 - 2 Abbacchiatori pneumatici.
 - 2 Forbici pneumatiche.
 - 2 Aste telescopiche alluminio 1,25 - 1,95 mt.
 - 2 Tubi poliuretano 8x10 - 20 mt. con rubinetti.
- Kit acceleratore di serie

Kit Easy 430





Complete kit for two working position, suitable for harvesting and pruning of orchards, vineyards, olive-groves of small area dimensions.

- 1 Motocompressore CRS 1055/430 with petrol engine 5,5 Hp.
 - 2 Pneumatic harvester.
 - 2 Pneumatic shear.
 - 2 Telescopic extension poles 1,25 - 1,95 mt.
 - 2 Polyurethane hose 8x10 - 20 mt. with rapid connection.
- Self throttle kit included

																	
Type	Lt.	Type	L/min.	m ³ /h	c.f.m.	HP	r.p.m.	n.	Stage n.	bar	p.s.i.	kg	L	B	H	LpA (R:1m-H:1m)	LwA
KIT EASY 430	10	K 17/C	430	25,8	14,69	5,5	1300	2	1	11	160	62	880	690	880	≤ 94	97

KIT PROFI 520



			
Type	n.	n.	n.
KIT PROFI 520	2	5	1

Kiy Profi 520

Kit professionale equipaggiato per due postazione di lavoro complete. - Adatto per la raccolta e la potatura in aziende agricole di piccole-medie dimensioni. -











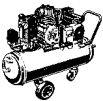

- 1 Motocompressore TTS 3465/520 con motore benzina 6,5 Hp.
- 2 Abbacchiatori pneumatici.
- 2 Forbici pneumatiche.
- 2 Aste telescopiche alluminio 1,25 - 1,95 mt.
- 2 Tubi poliuretano 8x10 - 20 mt. con rubinetti.

Kit acceleratore di serie

Kit Profi 520

Professional kit equipped for two complete working position. - Suitable for harvesting and pruning in small-medium farms. -

- 1 Motocompressor TTS 3465/520 with petrol engine 6,5 Hp.
- 2 Pneumatic harvester.
- 2 Pneumatic shear.
- 2 Telescopic extension poles 1,25 - 1,95 mt.
- 2 Polyurethane hose 8x10 - 20 mt. with rapid connection. Self throttle kit included

																	
Type	Lt.	Type	L/min.	m ³ /h	c.f.m.	HP	r.p.m.	n.	Stage n.	bar	p.s.i.	kg	L	B	H	LpA (Rc,1m+H,1m)	LwA
KIT PROFI 520	17+17	K18/C	520	31,2	18,36	6,5	1300	2	1	11	160	78	1170	770	900	≤ 95	97











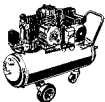



Motocompressore

Motocompressore con motore a scoppio a benzina 4 tempi. -
 Avviamento a strappo con fune autoavvolgente. -
 Testata bicilindrica monostadio in ghisa con valvole in acciaio inox. -
 Completo di valvola automatica di messa a vuoto che mantiene la pressione costante nel serbatoio. -

Petrol engine air compressors

Air compressor with 4-stroke petrol engine. -
 Self rewinding rope starter. -
 Two-cylinders cast iron single stage head with stainless steel valve. -
 Complete with automatic vacuum valve, which maintains a constant pressure in the tank. -

																	
			Type	Lt.	Type					L/min.	m ³ /h		c.f.m.	HP	r.p.m.	n.	Stage n.
CRS 54	50	K11	220	13,2	7,77	4	900	2	1	10	145	85	1270	490	880	≤ 94	97
CRS 104	100	K11	220	13,2	7,77	4	900	2	1	10	145	85	1270	490	880	≤ 94	97
CRS 155	150	K17	321	19,26	11,33	5,5	900	2	1	10	145	104	1490	510	920	≤ 94	97
CRS 206	200	K18	385	23,1	13,6	6,5	900	2	1	10	145	120	1580	530	1010	≤ 94	97











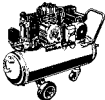



Motocompressori

Motocompressori altamente professionali con motore a scoppio benzina 4 tempi. Testate bicilindriche bistadio in ghisa ad elevato rendimento d'aria. Una puleggia centrifuga disconnette la testata quando il motore viene portato al minimo garantendo bassi consumi ed una minima usura. Completo di valvola automatica di messa a vuoto, filtro-riduttore-lubrificatore, ripartitore con attacchi multipli, avviamento elettrico con batteria.

Petrol engine air compressors

Professionals air compressor with 4-stroke petrol engine. Two-cylinders head with cast iron two-stage at high performance air delivery. A centrifugal pulley disconnects the compressor head when motor is at the lowest speed, garanting low consumption and a minimum wear. Complete with automatic vacuum valve, filter-reducer-lubricator, distribution manifold, electric start with battery.

											
Type	Lt.	Type	L/min. m ³ /h c.f.m.	HP	r.p.m.	n.	Stage n.	bar p.s.i.	kg	L B H	LpA (R:1m-H:1m) LwA
CRS 309	270	K28	610 36,61 21,53	9	1300	2	2	10 145	153	1700 720 1150	≤ 96 97
CRS 511	500	K30	900 54,02 31,77	11	1250	2	2	10 145	200	2130 740 1350	≤ 96 97











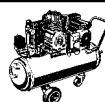
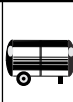

Motocompressore diesel

Motocompressore altamente professionale con motore a scoppio diesel 4 tempi. Avviamento a strappo con fune autoavvolgente. L'installazione di serie del kit acceleratore permette la riduzione di consumi ed usura. Testata bicilindrica monostadio con cilindro in ghisa. Completo di valvola automatica di sfiato e messa a vuoto che mantiene la pressione costante nel serbatoio. Completo di filtro - riduttore - lubrificatore e due rubinetti universali.

Diesel engine air compressors

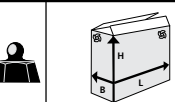
Professional air compressor with 4-stroke diesel engine. Self rewinding rope starter. The serial installation of self throttle kit reducing consumption and wear. Single stage two cylinders compressor heads with cast iron cylinder. Automatic release valve and vacuum setting which maintains a constant pressure in the tank. Complete with filter - reducer - lubricator and two universal rapid cock.

																	
Type	Lt.	Type	L/min.	m ³ /h	c.f.m.	HP	r.p.m.	n.	Stage n.	bar	p.s.i.	kg	L	B	H	LpA (R:1m+H:1m)	LwA
CRD 104	100	K 18/C	520	31,2	18,3	4,2	1300	2	1	10	145	104	1270	490	880	≤ 96	97











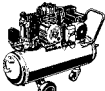



Motocompressori





Motocompressore altamente professionale con motore a scoppio diesel 4 tempi. -
 Avviamento elettrico con batteria. -
 L'installazione di serie del kit acceleratore e della puleggia centrifuga permette la disconnessione automatica della testata in mancanza di richiesta d'aria, -
 riducendo consumi ed usura. -
 Completo di valvola automatica di messa a vuoto, batteria, filtro-riduttore-lubrificatore, ripartitore con attacchi multipli. -

Petrol engine air compressors

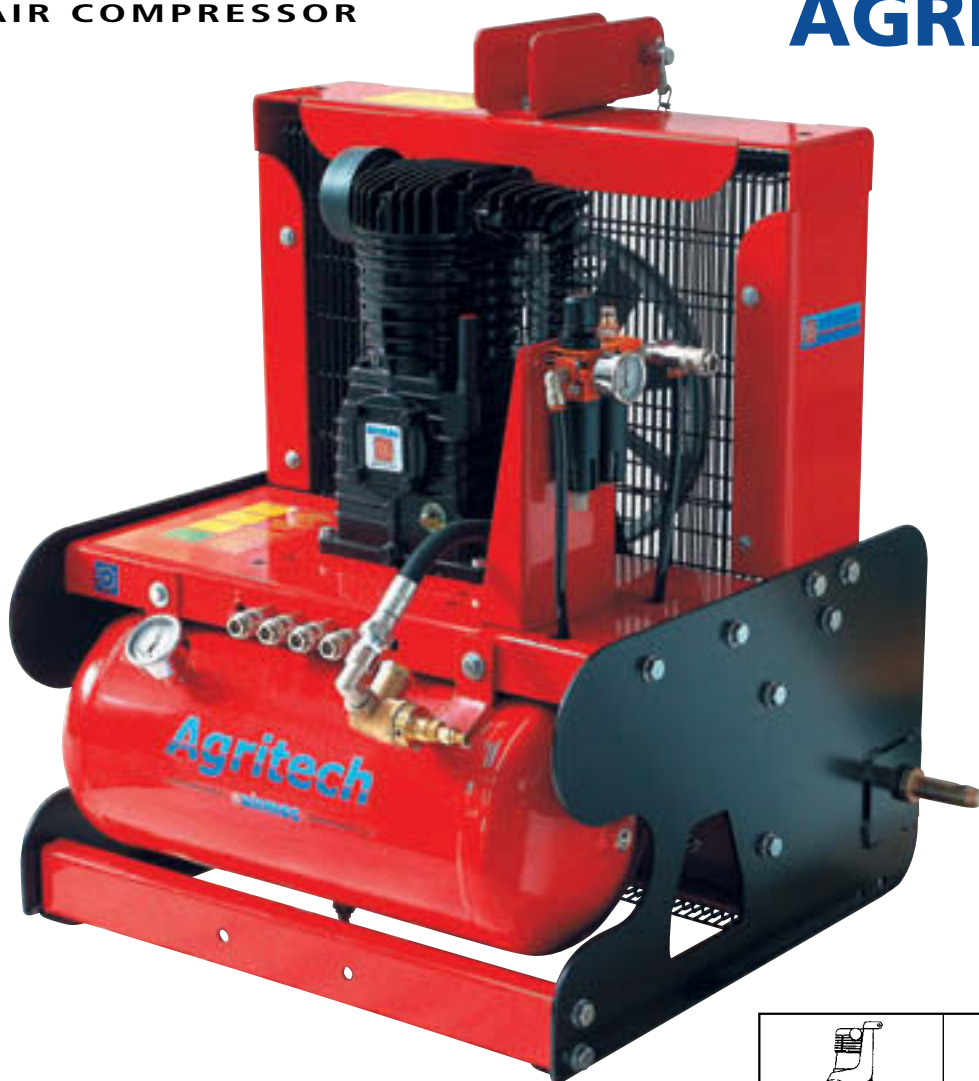
Motocompressore altamente professionale con motore a scoppio diesel 4 tempi. -
 Avviamento elettrico con batteria. -
 L'installazione di serie del kit acceleratore e della puleggia centrifuga permette la disconnessione automatica della testata in mancanza di richiesta d'aria, -
 riducendo consumi ed usura. -
 Completo di valvola automatica di messa a vuoto, batteria, filtro-riduttore-lubrificatore, ripartitore con attacchi multipli. -

																	
Type	Lt.	Type	L/min.	m ³ /h	c.f.m.	HP	r.p.m.	n.	Stage n.	bar	p.s.i.	kg	L	B	H	LpA (R:1m-H:1m)	LwA
CRD 206	200	K28	610	36,61	21,53	6	1300	2	2	10	145	145	1580	530	990	≤ 96	97
CRD 309	270	K30	900	54,02	31,77	9,6	1250	2	2	10	145	190	1780	720	1150	≤ 96	97
CRD 509	500	K30	900	54,02	31,77	9,6	1250	2	2	10	145	230	2130	740	1470	≤ 96	97















			
Type	n.	n.	n.
AGRITECH 540	2	5	1

Compressori portati attacco tre punti trattore.





Sono caratterizzati da testate super professionali con cilindro e piatto valvole in ghisa, per un elevato rendimento ed una lunga durata. Il telaio compatto e robusto è dotato di gruppo filtro-riduttore-lubrificatore, manometri in bagno di glicerina e rubinetti rapidi multipli per il lavoro contemporaneo fino a 6 operatori. La completezza della gamma rende i modelli della gamma Agritech adatti sia alla piccola che alla grande azienda. Tutti i modelli della serie Agritech sono predisposti per essere carrellati.

Compressors suitable to be attached to the three points of the tractor.

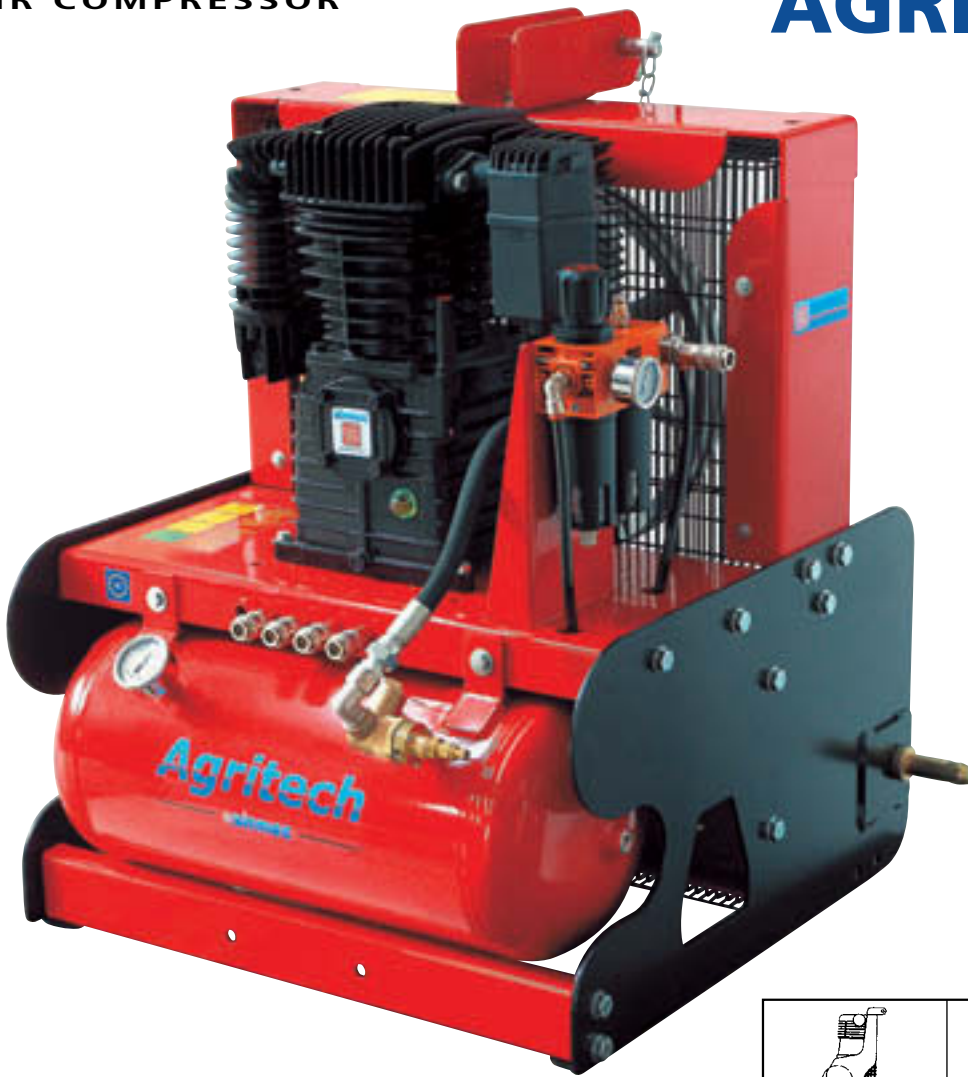
Their super professional heads with cylinder and valve plate in cast iron assure a high performance and a long lasting work. The compact and solid frame is equipped with a filter-reducer-lubricator group, glycerine-bath pressure gauges and multiple rapid cocks which allows up to 6 operators working at the same time. All models of the line Agritech are suitable for both small and large farms thanks to their complete range from 540 to 1500 lt./min. of air displacement. All models of the line Agritech can be provided with wheels.

															
Type	Lt.	Type	L/min.	m ³ /h	r.p.m. max	HP	r.p.m. p.d.f.	n.	Stage n.	bar	p.s.i.	kg	L	B	H
AGRITECH 540	25	K18/C	539	19	1400	20	250/325	2	1	11	160	88	680	670	850













			
Type	n.	n.	n.
AGRITECH 650	3 - 4	7	1 - 2

Compressori portati attacco tre punti trattore.

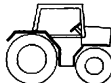



Sono caratterizzati da testate super professionali con cilindro e piatto valvole in ghisa, per un elevato rendimento ed una lunga durata. Il telaio compatto e robusto è dotato di gruppo filtro-riduttore-lubrificatore, manometri in bagno di glicerina e rubinetti rapidi multipli per il lavoro contemporaneo fino a 6 operatori. La completezza della gamma rende i modelli della gamma Agritech adatti sia alla piccola che alla grande azienda. Tutti i modelli della serie Agritech sono predisposti per essere carrellati.

Compressors suitable to be attached to the three points of the tractor.

Their super professional heads with cylinder and valve plate in cast iron assure a high performance and a long lasting work. The compact and solid frame is equipped with a filter-reducer-lubricator group, glycerine-bath pressure gauges and multiple rapid cocks which allows up to 6 operators working at the same time. All models of the line Agritech are suitable for both small and large farms thanks to their complete range from 540 to 1500 lt./min. of air displacement. All models of the line Agritech can be provided with wheels.

															
Type	Lt.	Type	L/min.	m ³ /h	r.p.m. max	HP	r.p.m. p.d.f.	n.	Stage n.	bar	p.s.i.	kg	L	B	H
AGRITECH 650	25	K28	644	23	1400	25	250/325	2	2	11	160	95	680	670	850















			
Type	n.	n.	n.
AGRITECH 1000	4 - 5	9	2

Compressori portati attacco tre punti trattore.





Sono caratterizzati da testate super professionali con cilindro e piatto valvole in ghisa, per un elevato rendimento ed una lunga durata. Il telaio compatto e robusto è dotato di gruppo filtro-riduttore-lubrificatore, manometri in bagno di glicerina e rubinetti rapidi multipli per il lavoro contemporaneo fino a 6 operatori. La completezza della gamma da 540 a 1500 litri al minuto di aria aspirata rende i modelli della gamma Agritech adatti sia alla piccola che alla grande azienda. Tutti i modelli della serie Agritech sono predisposti per essere carrellati.

Compressors suitable to be attached to the three points of the tractor .

Their super professional heads with cylinder and valve plate in cast iron assure a high performance and a long lasting work. The compact and solid frame is equipped with a filter-reducer-lubricator group, glycerine-bath pressure gauges and multiple rapid cocks which allows up to 6 operators working at the same time. All models of the line Agritech are suitable for both small and large farms thanks to their complete range from 540 to 1500 lt./min. of air displacement. All models of the line Agritech can be provided with wheels.

															
Type	Lt.	Type	L/min.	m ³ /h	r.p.m.	HP	r.p.m.	n.	Stage n.	bar	p.s.i.	kg	L	B	H
AGRITECH 1000	25	K30	1020	35,9	1400	30	250/325	2	2	11	160	106	680	670	850



			
Type	n.	n.	n.
AGRIMASTER 650 / 270	3 - 4	7	1

Compressori portati attacco tre punti trattore.











Nuova gamma di compressori portati ideati per la raccolta e la potatura di uliveti, vigneti e frutteti. I gruppi pompanti utilizzati, altamente professionali uniscono elevate portate d'aria ad una assoluta affidabilità. I compressori della serie Agrimaster sono dotati di filtro-riduttore-lubrificatore, manometri in bagno di glicerina, rubinetti rapidi multipli e supporto per avvolgitore. La completezza della gamma con unità pompanti da 640 a 1500 litri al minuto accoppiati a serbatoi da 270 e 650 lt consente di lavorare diverse ore a trattore spento, riducendo usura, consumo di carburante ed inquinamento acustico.

Tutti i modelli della serie Agrimaster sono predisposti per essere montati su carrello.

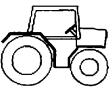
Compressors suitable to be attached to the three points of the tractor .





New range of portable compressors created for harvesting and pruning olive groves, vineyards and fruit orchards. The highly professional pumping sets used unite elevated air capacity with absolute reliability . The Agrimaster series compressors are equipped with filter-reduction gear-lubricator, manometer in glycerine bath, multiple rapid taps and coiler support. The complete range with 640 to 1500 litres per minute pumping unit coupled to 270 and 650 litre tanks allows working for several hours with the tractor turned off, reducing wear, consumption of fuel and acoustic pollution.

All the models of the Agrimaster series can be mounted on trolleys.

															
Type	Lt.	Type	L/min.	m ³ /h	r.p.m.	HP	r.p.m.	n.	Stage n.	bar	p.s.i.	kg	L	B	H
AGRIMASTER 650 / 270	272	K28	644	23	1400	25	250/325	2	2	14,5	210	285	1500	1550	1060

AGRIMASTER 1000



			
Type	n.	n.	n.
AGRIMASTER 1000 / 650	5	12	2













Compressori portati attacco tre punti trattore.

Nuova gamma di compressori portati ideati per la raccolta e la potatura di uliveti, vigneti e frutteti. I gruppi pompanti utilizzati, altamente professionali uniscono elevate portate d'aria ad una assoluta affidabilità. I compressori della serie Agrimaster sono dotati di filtro-riduttore-lubrificatore, manometri in bagno di glicerina, rubinetti rapidi multipli e supporto per avvolgitore. La completezza della gamma con unità pompanti da 640 a 1500 litri al minuto accoppiati a serbatoi da 270 e 650 lt consente di lavorare diverse ore a trattore spento, riducendo usura, consumo di carburante ed inquinamento acustico.

Tutti i modelli della serie Agrimaster sono predisposti per essere montati su carrello.





Compressors suitable to be attached to the three points of the tractor.

New range of portable compressors created for harvesting and pruning olive groves, vineyards and fruit orchards. The highly professional pumping sets used unite elevated air capacity with absolute reliability. The Agrimaster series compressors are equipped with filter-reduction gear-lubricator, manometer in glycerine bath, multiple rapid taps and coiler support. The complete range with 640 to 1500 litres per minute pumping unit coupled to 270 and 650 litre tanks allows working for several hours with the tractor turned off, reducing wear, consumption of fuel and acoustic pollution. All the models of the Agrimaster series can be mounted on trolleys.

															
Type	Lt.	Type	L/min.	m ³ /h	r.p.m.	HP	r.p.m.	n.	Stage n.	bar	p.s.i.	kg	L	B	H
AGRIMASTER 1000 / 650	650	K30	1020	35,9	1400	30	250/325	2	2	14,5	210	380	1500	1550	1060

AGRIMASTER 1500



			
Type	n.	n.	n.
AGRIMASTER 1500 / 650	7 - 8	13	3

Compressori portati attacco tre punti trattore.

Nuova gamma di compressori portati ideati per la raccolta e la potatura di uliveti, vigneti e frutteti. I gruppi pompanti utilizzati, altamente professionali uniscono elevate portate d'aria ad una assoluta affidabilità. I compressori della serie Agrimaster sono dotati di filtro-riduttore-lubrificatore, manometri in bagno di glicerina, rubinetti rapidi multipli e supporto per avvolgitore. La completezza della gamma con unità pompanti da 640 a 1500 litri al minuto accoppiati a serbatoi da 270 e 650 Lt consente di lavorare diverse ore a trattore spento, riducendo usura, consumo di carburante ed inquinamento acustico.











Tutti i modelli della serie Agrimaster sono predisposti per essere montati su carrello.

Compressors suitable to be attached to the three points of the tractor .

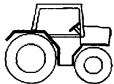
New range of portable compressors created for harvesting and pruning olive groves, vineyards and fruit orchards.

The highly professional pumping sets used unite elevated air capacity with absolute reliability. The Agrimaster series compressors are equipped with filter-reduction gear-lubricator, manometer in glycerine bath, multiple rapid taps and coiler support.





The complete range with 640 to 1500 litres per minute pumping unit coupled to 270 and 650 litre tanks allows working for several hours with the tractor turned off, reducing wear, consumption of fuel and acoustic pollution. All the models of the Agrimaster series can be mounted on trolleys.

															
Type	Lt.	Type	L/min.	m ³ /h	r.p.m.	HP	r.p.m.	n.	Stage n.	bar	p.s.i.	kg	L	B	H
AGRIMASTER 1500 / 650	650	K50	1503	53,1	1400	40	250/325	2	2	14,5	210	410	1500	1550	1060

AGRIPLUS 1000/500

AGRIPLUS 1500/500



			
Type	n.	n.	n.
AGRIPLUS 1000/500	5	12	2
AGRIPLUS 1500/500	7 - 8	15	3

Compressori portati attacco tre punti trattore.









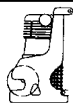

Nuova gamma di compressori portati ideati per la raccolta e la potatura di uliveti, vigneti e frutteti. I gruppi pompanti utilizzati, altamente professionali uniscono elevate portate d'aria ad una assoluta affidabilità. I compressori della serie Agriplus sono dotati di filtro-riduttore-lubrificatore, manometri in bagno di glicerina, rubinetti rapidi multipli e supporto per avvolgitore. La completezza della gamma con unità pompanti da 1000 a 1500 litri al minuto accoppiati a serbatoi verticali da 500 e 1000 Lt consente di lavorare diverse ore a trattore spento, riducendo usura, consumo di carburante ed inquinamento acustico. Tutti i modelli della serie Agriplus sono predisposti per essere montati su carrello.

Compressors suitable to be attached to the three points of the tractor .

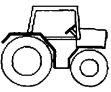
New range of portable compressors created for harvesting and pruning olive groves, vineyards and fruit orchards.

The highly professional pumping sets used unite elevated air capacity with absolute reliability. The Agriplus series compressors are equipped with filter-reduction gear-lubricator, manometer in glycerine bath, multiple rapid taps and coiler support. The complete range with 1000 to 1500 litres per minute pumping unit coupled to 500 and 1000 litre vertical tanks allows working for several hours with the tractor turned off, reducing wear, consumption of fuel and acoustic pollution.





All the models of the Agrimaster series can be mounted on trolleys.

															
Type	Lt.	Type	L/min.	m ³ /h	r.p.m.	HP	r.p.m.	n.	Stage n.	bar	p.s.i.	kg	L	B	H
AGRIPLUS 1000/500	500	K30	1020	35,9	1400	30	250/325	2	2	14,5	210	340	650	1560	1950
AGRIPLUS 1500/500	500	K50	1503	53,1	1400	40	250/325	2	2	14,5	210	378	650	1560	1950

AGRIPLUS 1000/1000

AGRIPLUS 1500/1000



			
Type	n.	n.	n.
AGRIPLUS 1000/1000	5	12	2
AGRIPLUS 1500/1000	7 - 8	15	3









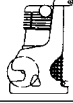

Compressori portati attacco tre punti trattore.

Nuova gamma di compressori portati ideati per la raccolta e la potatura di uliveti, vigneti e frutteti. I gruppi pompanti utilizzati, altamente professionali uniscono elevate portate d'aria ad una assoluta affidabilità. I compressori della serie Agriplus sono dotati di filtro-riduttore-lubrificatore, manometri in bagno di glicerina, rubinetti rapidi multipli e supporto per avvolgitore. La completezza della gamma con unità pompanti da 1000 a 1500 litri al minuto accoppiati a serbatoi verticali da 500 e 1000 Lt consente di lavorare diverse ore a trattore spento, riducendo usura, consumo di carburante ed inquinamento acustico.

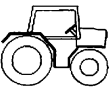
Tutti i modelli della serie Agriplus sono predisposti per essere montati su carrello.

Compressors suitable to be attached to the three points of the tractor .









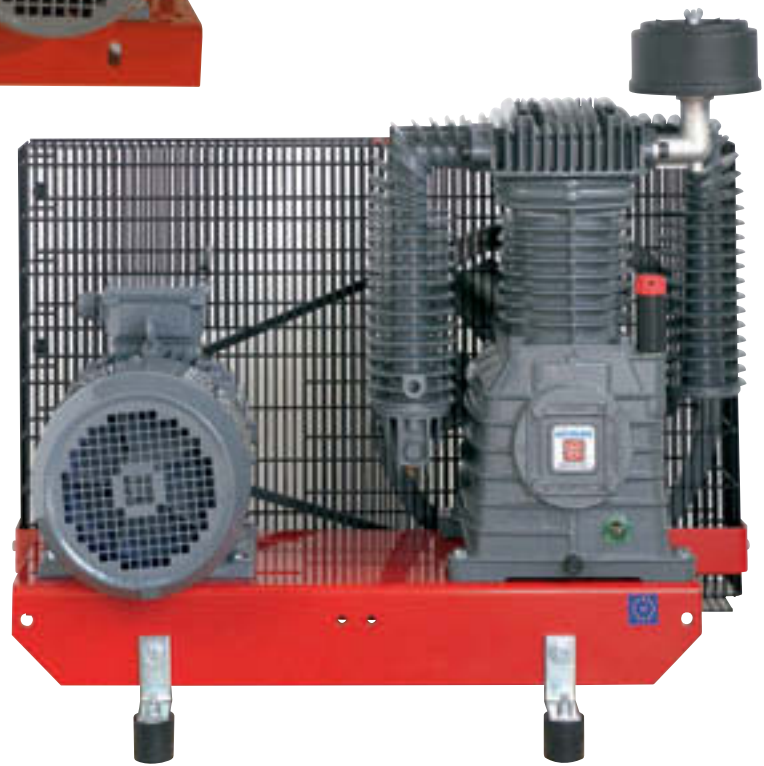

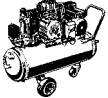

New range of portable compressors created for harvesting and pruning olive groves, vineyards and fruit orchards. The highly professional pumping sets used unite elevated air capacity with absolute reliability . The Agriplus series compressors are equipped with filter-reduction gear-lubricator, manometer in glycerine bath, multiple rapid taps and coiler support. The complete range with 1000 to 1500 litres per minute pumping unit coupled to 500 and 1000 litre vertical tanks allows working for several hours with the tractor turned off, reducing wear, consumption of fuel and acoustic pollution. All the models of the Agriplus series can be mounted on trolleys.

															
Type	Lt.	Type	L/min.	m ³ /h	r.p.m.	HP	r.p.m.	n.	Stage n.	bar	p.s.i.	kg	L	B	H
AGRIPLUS 1000/1000	1000	K30	1020	35,9	1400	30	250/325	2	2	14,5	210	404	900	1880	1810
AGRIPLUS 1500/1000	1000	K50	1503	53,1	1400	40	250/325	2	2	14,5	210	437	900	1880	1810

MT

GRUPPI COMPRESSORE SU BASE COMPRESSORS GROUPS ON BASE PLATES



																			
Type	Type	L/min.	m ³ /h	c.f.m.	kW	HP	Volt	Amp.	r.p.m.	n.	Stage n.	bar	p.s.i.	kg	L	B	H	LpA (R-T11-H-1m)	LwA
MT 1008 M	K8	145	8,7	5,12	0,75	1	230	5,5	850	1	1	10	145	26	550	350	400	≤ 72	90
MT 1511 M	K11	220	13,2	7,77	1,1	1,5	230	8,2	850	2	1	10	145	31	550	350	400	≤ 74	90
MT 2017 M	K17	321	19,26	11,33	1,5	2	230	10	850	2	1	10	145	36	660	390	440	≤ 72	90
MT 3018 M	K18	385	23,1	13,6	2,2	3	230	13	850	2	1	10	145	40	660	390	440	≤ 78	90
MT 4028 T	K28	460	27,6	16,3	3	4	230/400	6,7	900	2	2	10	145	72	940	480	620	≤ 76	99
MT 5530 T	K30	727	43,62	25,7	4	5,5	230/400	8,6	850	2	2	10	145	88	940	480	620	≤ 76	99
MT 7550 T	K50	1074	64,44	37,9	5,5	7,5	230/400	11,4	850	2	2	10	145	97	1120	510	700	≤ 76	99
MT 10060 T	K60	1454	82,24	51,3	7,5	10	230/400	14,8	850	4	2	10	145	105	1120	510	720	≤ 76	99

CH

Compressori coassiali monocilindrici

Corpo e testa in alluminio pressofuso, cilindro ed eccentrico in ghisa, lubrificazione a sbattimento, valvole inox ad alto rendimento, raffreddamento forzato.

Single cylinder direct driven compressors

The cast aluminium casing and head, cast iron cylinder and eccentric, splash lubrication, high performance stainless steel valves, forced cooling.



Type	Flow			cm ³	Power		Volt	Amp.	r.p.m.	n.	Stage n.	Pressure		kg	Dimensions			Sound	
	L/min.	m ³ /h	c.f.m.		kW	HP						bar	p.s.i.		L	B	H	LpA (R:1m-H:1m)	LwA
CH 110	115	6,9	4,1	82,5	0,75	1	230	4,7	1400	1	1	10	145	13	360	200	300	≤ 78	90
CH 210	220	13,2	7,6	82,5	1,5	2	230	8,2	2800	1	1	10	145	13	360	200	300	≤ 78	90
CHT 110	115	6,9	4,1	82,5	0,75	1	230/400	1,5	1400	1	1	10	145	13	360	200	300	≤ 78	90

CHB

Compressori coassiali bicilindrici

Corpo e testa in alluminio pressofuso, cilindri ed eccentrici in ghisa, lubrificazione a sbattimento, valvole inox ad alto rendimento, raffreddamento forzato.

Two cylinder direct driven compressors

Cast aluminium casing and head, cast iron cylinders and eccentrics, splash lubrication, high performance stainless steel valves, forced cooling.



Type	Flow			cm ³	Power		Volt	Amp.	r.p.m.	n.	Stage n.	Pressure		kg	Dimensions			Sound	
	L/min.	m ³ /h	c.f.m.		kW	HP						bar	p.s.i.		L	B	H	LpA (R:1m-H:1m)	LwA
CHB 230	230	13,8	8	165	1,5	2	230	9,7	1400	2V	1	10	145	21	420	400	400	≤ 78	90
CHBT 230	230	13,8	8	165	1,5	2	230/400	2,6	1400	2V	1	10	145	21	420	400	400	≤ 78	90

K8 - K11

COMPRESSORI MONOSTADIO















K 8

K 11



Compressori Monostadio

Compressori monostadio con albero in ghisa sferoidale, valvole in acciaio inox, cilindri e piastre in ghisa, gusci in lega antiflessione, volani in alluminio e in ghisa, filtri d'aspirazione con cartucce intercambiabili.

																				
Type	L/min.	m ³ /h	c.f.m.	L/min.	m ³ /h	c.f.m.	cm ³	kW	HP	r.p.m.	n.	Stage n.	bar	p.s.i.	mm	inch.	mm	inch.	Type	kg
K 8	145	8,7	5,12	105	6,3	3,65	148	0,75	1	1000	1	1	8+10	116+145	46	1,81	280	11,02	1A	7,9
K 11	220	13,2	7,77	154	9,24	5,44	220	1,1	1,5	1000	2	1	8+10	116+145	50	1,97	280	11,02	1A	10,3

K17 - K18

SINGLE-STAGE COMPRESSORS



K 17



K 18

Single-stage Compressors

Single-stage compressors with spherical cast iron shaft, cylinders and valves of plated cast iron, rustproof plated steel valves, rigid alloy shells, aluminium and cast iron fly wheels, aspiration filters with changeable cartridges.

Type	L/min.	m ³ /h	c.f.m.	L/min.	m ³ /h	c.f.m.	cm ³	kW	HP	r.p.m.	n.	Stage n.	bar	p.s.i.	mm	inch.	mm	inch.	Type	kg
K 17	321	19,26	11,33	231	13,86	8,15	321	1,5	2	1000	2	1	8+10	116+145	50	1,97	320	12,6	1A	14,9
K 18	385	23,1	13,6	277	16,62	9,78	385	2,2	3	1000	2	1	8+10	116+145	50	1,97	320	12,6	1A	17,4

K28 - K30

COMPRESSORI BISTADIO















K 28



K 30

Compressori Bistadio

Compressori bistadio con albero in ghisa sferoidale, valvole in acciaio inox, cilindri e piastre in ghisa, gusci in lega antiflessione, volani in alluminio e in ghisa, filtri d'aspirazione con cartucce intercambiabili.

																				
Type	L/min.	m ³ /h	c.f.m.	L/min.	m ³ /h	c.f.m.	cm ³	kW	HP	r.p.m.	n.	Stage n.	bar	p.s.i.	mm	inch.	mm	inch.	Type	kg
K 28	460	27,6	16,3	354	21,24	12,5	460	3	4	1000	2	2	10+12	145+174	65	2,56	385	15,16	1A	26,2
K 30	727	43,62	25,7	582	34,92	20,5	727	4	5,5	1000	2	2	10+12	145+174	84	3,31	400	15,75	1B	37,6

K50 - K60

TWO-STAGE COMPRESSORS



K 50

K 60



Two-stage Compressors

Two-stage compressors with spherical cast iron shaft, cylinders and valves of plated cast iron, rustproof plated steel valves, rigid alloy shells, aluminium and cast iron fly wheels, aspiration filters with changeable cartridges.

Type	L/min.	m ³ /h	c.f.m.	L/min.	m ³ /h	c.f.m.	cm ³	kW	HP	r.p.m.	n.	Stage n.	bar	p.s.i.	mm	inch.	mm	inch.	Type	kg
K 50	1074	64,44	37,9	849	50,94	30	1074	5,5	7,5	1000	2	2	10+12	145+174	95	3,74	550	21,65	2B	71,5
K 60	1454	82,24	51,3	1149	68,94	40,6	1454	7,5	10	1000	4	2	10+12	145+174	84	3,31	550	21,65	2B	84



Power
Line



Kit Power 300







Kit completo per una postazione di lavoro, - ideale per la raccolta - e la potatura di frutteti, vigneti, oliveti di piccole dimensioni. -

- 1 Motocompressore con motore benzina 4 Hp.
 - 1 Abbacchiatore pneumatico.
 - 1 Asta telescopica alluminio 1,25 - 1,95 mt.
 - 1 Tubo poliuretano 8x10 - 20 mt. con rubinetti.
- Kit acceleratore di serie

Kit Power 300

Complete kit for one working position, suitable for harvesting and pruning of orchards, vineyards, olive-groves of small area dimensions.

- 1 Motocompressore with petrol engine 4 Hp.
 - 1 Pneumatic harvester.
 - 1 Telescopic extension poles 1,25 - 1,95 mt.
 - 1 Polyurethane hose 8x10 - 20 mt. with rapid connection.
- Self throttle kit included

							C/1'
Type	HP	Lt.	Type	L/min.	m ³ /h	bar	r.p.m.
KIT POWER 300	4	10	AB 248	270	16,2	10	1350

Power
Line



Kiy Power 500

Kit completo per 2 postazioni di lavoro, ideale per la raccolta e la potatura di frutteti, vigneti, oliveti di piccole dimensioni.







- 1 Motocompressore con motore benzina 6,5 Hp.
 - 2 Abbacchiatori pneumatici.
 - 2 Aste telescopiche alluminio 1,25 - 1,95 mt.
 - 2 Tubi poliuretano 8x10 - 20 mt. con rubinetti.
- Kit acceleratore di serie

Kit Power 500

Complete kit for two working position, suitable for harvesting and pruning of orchards, vineyards, olive-groves of small area dimensions.

- 1 Motocompressore with petrol engine 6,5 Hp.
- 2 Pneumatic harvester.
- 2 Telescopic extension poles 1,25 - 1,95 mt.
- 2 Polyurethane hose 8x10 - 20 mt. with rapid connection.

Self throttle kit included

							
Type	HP	Lt.	Type	L/min.	m ³ /h	bar	r.p.m.
KIT POWER 500	6,5	10	SBK4	520	32,4	10	1350



Power
Line



Compressori portatili







Serbatoio munito di piedini antivibranti, -
maniglia di trasporto, rubinetto scarico -
condensa, valvola di ritegno. -

Dispositivi di controllo composti da: manometri, -
valvola sicurezza, riduttore di pressione con -
filtro, pressostato e cavo di alimentazione con -
spina. -

Portable compressors

Tank provided with anti-vibration feet, carrying
handle, condense drain cock, non return valve.

The control device includes: pressure gauges,
safety valve, pressure reducer with filter,
pressure switch and electric cable with plug.

								C/1'
Type	Volt	Lt.	Type	L/min.	m ³ /h	kW	HP	r.p.m.
PAC 2000 PL	230	4+4	CH 210 PL	220	13,2	1,5	2	2800



Power
Line









Compressori carrellati monocilindrici

Compressori carrellati completi di maniglia e di ruote, per un facile spostamento. -
 Funzionamento automatico comandato da pressostato e valvola di ritegno. -
 Dotati di strumenti di controllo: manometri, valvola di sicurezza, -
 riduttore di pressione con rubinetto - portagomma e valvola scarico condensa. -

Wheel mounted single cylinder compressors

Wheel mounted compressors provided with handle and wheels easy to be transported. -
 Automatic operation controlled by a pressure switch and a non return valve. -
 The control device include: pressure gauges, safety valve, pressure reducing valve with hose holder cock and condense drain valve. -

								C/1'
Type	Volt	Lt.	Type	L/min.	m ³ /h	kW	HP	r.p.m.
CH 25/210 PL	230	25	CH 210 PL	220	13,2	1,5	2	2800



Power
Line









Compressori carrellati monocilindrici

Compressori carrellati completi di maniglia e di ruote, per un facile spostamento. - Funzionamento automatico comandato da pressostato e valvola di ritegno. - Dotati di strumenti di controllo: manometri, - valvola di sicurezza, - riduttore di pressione con rubinetto - portagomma e valvola scarico condensa. -

Wheel mounted single cylinder compressors

Wheel mounted compressors provided with handle and wheels easy to be transported. - Automatic operation controlled by a pressure switch and a non return valve. - The control device include: pressure gauges, - safety valve, pressure reducing valve with hose holder cock and condense drain valve. -

								C/1'
Type	Volt	Lt.	Type	L/min.	m ³ /h	kW	HP	r.p.m.
CH 50/210 PL	230	50	CH 210 PL	220	13,2	1,5	2	2800



Power
Line



Compressori monostadio a cinghia







Testata cilindro in ghisa con valvole in acciaio inox.

Motore elettrico monofase sovradimensionato a forte coppia di avviamento completo di protezione termica a riarmo manuale. Il motore elettrico trifase è protetto da un interruttore magnetotermico.

Single-stage belt driven compressors

Cylinders cast iron head provided with stainless steel valves.

Single-phase oversized electric motor with high starting torque complete with thermal protection at manual reset. The three-phase electric motor is protected by an overload switch.

 Type	 Volt	 Lt.	 Type					 r.p.m.
				L/min.	m ³ /h	kW	HP	
CRM 52 PL	230	50	A 11	210	12,6	1,5	2	1200
CR 52 PL	230/400	50	A 11	210	12,6	1,5	2	1200



Power
Line









Compressori monostadio a cinghia

Testata cilindro in ghisa con valvole in acciaio inox. Motore elettrico monofase sovradimensionato a forte coppia di avviamento completo di protezione termica a riarmo manuale. Il motore elettrico trifase è protetto da un interruttore magnetotermico.

Single-stage belt driven compressors

Cylinders cast iron head provided with stainless steel valves. Single-phase oversized electric motor with high starting torque complete with thermal protection at manual reset. The three-phase electric motor is protected by an overload switch.

 Type	 Volt	 Lt.	 Type					C/1' r.p.m.
				L/min.	m ³ /h	kW	HP	
CRM 52-5 PL CR 52-5 PL	230	50	KC 111	240	14,4	1,8	2,5	1050
	230/400	50	KC 111	240	14,4	1,8	2,5	1050



Power
Line









Compressori monostadio a cinghia

Testata bicilindrica in ghisa con valvole in acciaio inox. Il motore elettrico monofase è sovradimensionato con forte coppia di avviamento completo di protezione termica a riarmo manuale. Il motore elettrico trifase è protetto da un interruttore magnetotermico.

Single-stage belt driven compressors

Two-cylinders cast iron head provided with stainless steel valves. The single-phase electric motor is oversized with high starting torque complete with thermal protection at manual reset. The three-phase electric motor is protected by an overload switch.

 Type	 Volt	 Lt.	 Type					 r.p.m.
				L/min.	m ³ /h	kW	HP	
CRM 102 PL	230	100	A 11	210	12,6	1,5	2	1200
CR 102 PL	230/400	100	A 11	210	12,6	1,5	2	1200



Power
Line









Compressori monostadio a cinghia

Testata bicilindrica in ghisa con valvole in acciaio inox. Il motore elettrico monofase è sovradimensionato con forte coppia di avviamento completo di protezione termica a riarmo manuale. Il motore elettrico trifase è protetto da un interruttore magnetotermico.

Single-stage belt driven compressors

Two-cylinders cast iron head provided with stainless steel valves. The single-phase electric motor is oversized with high starting torque complete with thermal protection at manual reset. The three-phase electric motor is protected by an overload switch.

 Type	 Volt	 Lt.	 Type					C/1' r.p.m.
				L/min.	m ³ /h	kW	HP	
CRM 102-5 PL	230	100	KC 111	270	16,2	1,8	2,5	1150
CR 102-5 PL	230/400	100	KC 111	270	16,2	1,8	2,5	1150



Power
Line









Compressori monostadio a cinghia

Testata bicilindrica in ghisa con valvole in acciaio inox. Il motore elettrico monofase è sovradimensionato con forte coppia di avviamento completo di protezione termica a riarmo manuale. Il motore elettrico trifase è protetto da un interruttore magnetotermico.

Single-stage belt driven compressors

Two-cylinders cast iron head provided with stainless steel valves. The single-phase electric motor is oversized with high starting torque complete with thermal protection at manual reset. The three-phase electric motor is protected by an overload switch.

 Type	 Volt	 Lt.	 Type					C/1' r.p.m.
				L/min.	m ³ /h	kW	HP	
CRM 103 PL	230	100	KC 117	330	19,8	2,2	3	1000
CR 103 PL	230/400	100	KC 117	330	19,8	2,2	3	1000



Power
Line









Compressori monostadio a cinghia

Testata bicilindrica in ghisa con valvole in acciaio inox. Il motore elettrico monofase è sovradimensionato con forte coppia di avviamento completo di protezione termica a riarmo manuale. Il motore elettrico trifase è protetto da un interruttore magnetotermico.

Single-stage belt driven compressors

Two-cylinders cast iron head provided with stainless steel valves. The single-phase electric motor is oversized with high starting torque complete with thermal protection at manual reset. The three-phase electric motor is protected by an overload switch.

 Type	 Volt	 Lt.	 Type					C/1' r.p.m.
				L/min.	m ³ /h	kW	HP	
CRM 152 PL	230	150	KC 111	270	16,2	1,8	2,5	1150
CR 152 PL	230/400	150	KC 111	270	16,2	1,8	2,5	1150



Power
Line









Compressori monostadio a cinghia

Testata bicilindrica in ghisa con valvole in acciaio inox. Il motore elettrico monofase è sovradimensionato con forte coppia di avviamento completo di protezione termica a riarmo manuale. Il motore elettrico trifase è protetto da un interruttore magnetotermico.

Single-stage belt driven compressors

Two-cylinders cast iron head provided with stainless steel valves. The single-phase electric motor is oversized with high starting torque complete with thermal protection at manual reset. The three-phase electric motor is protected by an overload switch.

 Type	 Volt	 Lt.	 Type					C/1' r.p.m.
				L/min.	m ³ /h	kW	HP	
CRM 153 PL CR 153 PL	230	150	KC 117	330	19,8	2,2	3	1000
	230/400	150	KC 117	330	19,8	2,2	3	1000



Power
Line









Compressori monostadio a cinghia

Testata bicilindrica in ghisa con valvole in acciaio inox. Il motore elettrico monofase è sovradimensionato con forte coppia di avviamento completo di protezione termica a riarmo manuale. Il motore elettrico trifase è protetto da un interruttore magnetotermico.

Single-stage belt driven compressors

Two-cylinders cast iron head provided with stainless steel valves. The single-phase electric motor is oversized with high starting torque complete with thermal protection at manual reset. The three-phase electric motor is protected by an overload switch.

 Type	 Volt	 Lt.	 Type					C/1' r.p.m.
				L/min.	m ³ /h	kW	HP	
CRM 203 PL CR 203 PL	230	200	KC 117	330	19,8	2,2	3	1000
	230/400	200	KC 117	330	19,8	2,2	3	1000



Power
Line









Compressori doppio stadio a cinghia

Testata bicilindrica in ghisa, valvole lamellari in acciaio inox ad elevata resistenza. - Funzionamento a basso regime di giri. - Il motore elettrico trifase protetto da interruttore magnetotermico installato direttamente sul pressostato. -

Two-stage belt driven compressors

Two-cylinders cast iron head provided with stainless steel valve. Functioning at low r.p.m. The three-phase electric motor is protected by an overload switch fitted directly on pressure switch.

								C/1'
Type	Volt	Lt.	Type	L/min.	m ³ /h	kW	HP	r.p.m.
CF 304 PL	230/400	270	KC 125	420	25,2	3	4	1000
CR 304 PL	230/400	270	KC 125	420	25,2	3	4	1000



Power
Line









Compressori doppio stadio a cinghia

Testata bicilindrica in ghisa, valvole lamellari in acciaio inox ad elevata resistenza. Funzionamento a basso regime di giri. Il motore elettrico trifase protetto da interruttore magnetotermico installato direttamente sul pressostato.

Two-stage belt driven compressors

Two-cylinders cast iron head provided with stainless steel valve. Functioning at low r.p.m. The three-phase electric motor is protected by an overload switch fitted directly on pressure switch.

 Type	 Volt	 Lt.	 Type					C/1' r.p.m.
				L/min.	m ³ /h	kW	HP	
CF 305 PL	230/400	270	KC 130	727	43,6	4	5,5	1000
CR 305 PL	230/400	270	KC 130	727	43,6	4	5,5	1000



Power
Line









Compressori doppio stadio a cinghia

Testata bicilindrica in ghisa, valvole lamellari in acciaio inox ad elevata resistenza. Funzionamento a basso regime di giri. Il motore elettrico trifase protetto da interruttore magnetotermico installato direttamente sul pressostato.

Two-stage belt driven compressors

Two-cylinders cast iron head provided with stainless steel valve. Functioning at low r.p.m. The three-phase electric motor is protected by an overload switch fitted directly on pressure switch.

								C/1'
Type	Volt	Lt.	Type	L/min.	m ³ /h	kW	HP	r.p.m.
CF 505 PL	230/400	500	KC 130	727	43,6	4	5,5	1000
CR 505 PL	230/400	500	KC 130	727	43,6	4	5,5	1000



Power
Line



Compressori coassiali monocilindrici

Corpo e testa in alluminio pressofuso, cilindro ed eccentrico in ghisa, lubrificazione a sbattimento, valvole inox ad alto rendimento, raffreddamento forzato.



Single cylinder direct driven compressors

The cast aluminium casing and head, cast iron cylinder and eccentric, splash lubrication, high performance stainless steel valves, forced cooling.

		
Type	L/min.	m ³ /h
CH 210 PL (25 Lt.)	220	13,2
CH 210 PL (50 Lt.)	220	13,2



Compressori Monostadio

Compressori monostadio con albero in ghisa sferoidale, valvole in acciaio inox, cilindri e piastre in ghisa.

Single-stage Compressors

Single-stage compressors with spherical cast iron shaft, cylinders and valves of plated cast iron.



		
Type	L/min.	m ³ /h
A 11	210	12,6



Power
Line



Compressori Monostadio -

Compressori monostadio con albero in ghisa sferoidale, valvole in acciaio inox, cilindri e piastre in ghisa.

Single-stage Compressors

Single-stage compressors with spherical cast iron shaft, cylinders and valves of plated cast iron.



		
Type	L/min.	m ³ /h
KC 111	240	14,4
KC 117	330	19,8



Compressori Bistadio -

Compressori Bistadio con albero in ghisa sferoidale, valvole in acciaio inox, cilindri e piastre in ghisa.

Two-stage Compressors

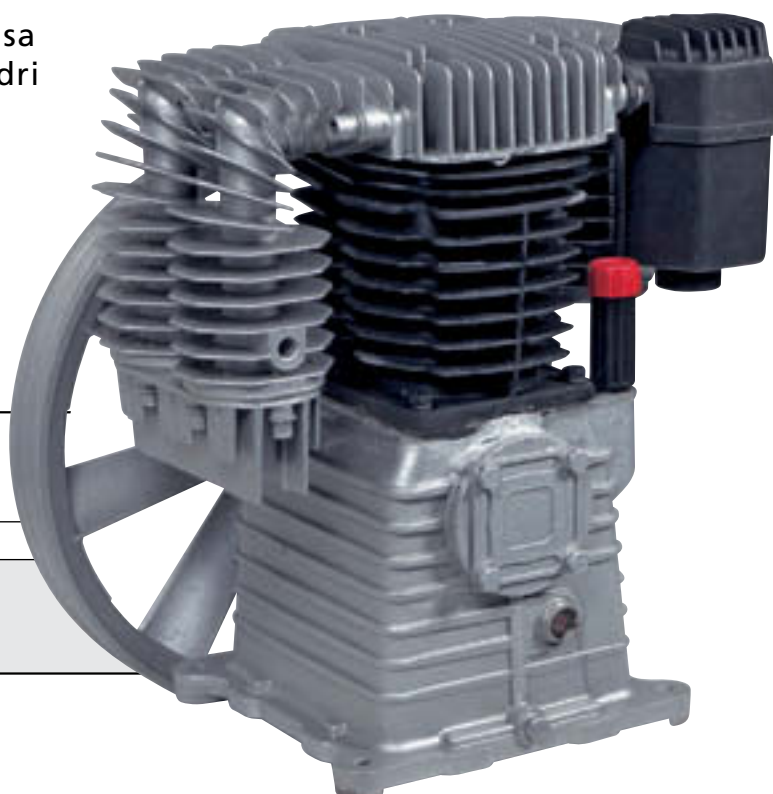
Two-stage compressors with spherical cast iron shaft, cylinders and valves of plated cast iron.



		
Type	L/min.	m ³ /h
KC 125	420	25,2
KC 130	727	43,6

Art. 701 -

Pistola per aria
in alluminio
Aluminium gun



Art. 703

Pistola per aria in alluminio
con canna prolungata.
Aluminium gun with extension.



Art. 725

Manometro controllo pressione.
Pressure gauge manometer.



Art. 735

Pistola di gonfiaggio con manometro.
Gun and manometer.



Art. 730

Pistola di gonfiaggio senza manometro
Gun without manometer





Art. 761

Pistola di lavaggio con serbatoio da lt. 1.
Washing gun with 1 lts. tank.



Art. 851

Pistola per sabbiatura completa
di tubo gomma.
*Sand blasting gun complete
with hose.*

**Art. 1102 - 1/2 kg -
Art. 1103 - 1 kg -**

Aerografo -
per verniciatura -
con serbatoio superiore. -
Foro ugello Ø mm 1,5 (art.1102) -
Foro ugello Ø mm 1,8 (art.1103) -
*Cup gun for painting
with upper tank.*
Nozzle Ø 1,5 mm (art.1102)
Nozzle Ø 1,8 mm (art.1103)



Aerografo
per verniciatura
con serbatoio
inferiore.
Foro ugello Ø mm 1,5 (art.1202)
Foro ugello Ø mm 1,8 (art.1204)
*Cup gun for painting with
lower tank.*
Nozzle Ø 1,5 mm (art.1202)
Nozzle Ø 1,8 mm (art.1204)

**Art. 1202 - 1 kg -
Art. 1204 - 1 kg -**



Art. M200 1/2"

Filtro depuratore d'aria.
Air cleaner filter.



Art. M100 1/4"

Filtro depuratore d'aria.
Air cleaner filter.



Art. M210 1/2" -

Lubrificatore d'aria a nebbia.
Fog lubricator.



Art. M110 1/4"

Lubrificatore d'aria a nebbia.
Fog lubricator.



Art. M120 1/4"

Filtro regolatore - lubrificatore.
Filter regulator - lubricator.



Art. M220 1/2"

Filtro regolatore - lubrificatore.
Filter regulator - lubricator.



Art. M140 1/4"

Regolatore di pressione
con filtro.
*Pressure regulator
with filter.*



Art. M240 1/2"

Regolatore di pressione
con filtro.
*Pressure regulator
with filter.*

Art. 840



Riduttore di pressione da 1/4" a una mandata.
Single delivery pressure reducer 1/4".

Art. 845



Riduttore di pressione da 3/8" a una mandata.
Single delivery pressure reducer 3/8".

Art. 850

Riduttore di pressione da 1/2" a due mandate.
Two deliveries pressure reducer 1/2".



Art. 1500

Kit accessori aria

- 1 Aerografo con serbatoio inferiore
- 1 Pistola aria
- 1 Pistola gonfiaggio
- 1 Pistola lavaggio nafta
- 8 Metri tubo plastica a spirale con attacchi a baionetta

Air accessory kit

- 1 Cup gun with lower tank
- 1 Air gun
- 1 Inflating gun
- 1 Gasoil washing gun
- 8 - Meters of flexible plastic hose with bayonet connectors





Art. 804
Art. 805
Art. 806

Manometro
Pressure gauge
Art. 804-1/8" 12 Bar D.40
Art. 805-1/4" 12 Bar D.50
Art. 806-1/4" 16 Bar D.63



Art. 274
Art. 275

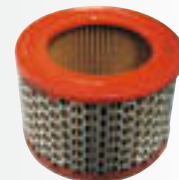

Art. 276

Cartuccia filtro
Filter cartridge
Art. 274 - 44x75x42
Art. 275 - 73x105x70
Art. 276 - 42x75x130



Art. 914

Pressostato Nema 1 via
Air pressure switch Nema 1 way



Art. 915

Pressostato Nema 4 vie
Air pressure switch Nema 4 ways



Art. 507
Art. 515

Tubo nylon elastico
D. 6x8 con raccordo.
Nylon hose
D. 6x8 with coupling.
Art. 507 mt. 7
Art. 515 mt. 15



Art. 301
Art. 302
Art. 303

Valvola di ritegno
maschio-femmina
Non return valve male-female
Art. 301 - 3/8"x3/8"
Art. 302 - 3/8"x1/2"
Art. 303 - 1/2"x1/2"



Art. 452
Art. 712
Art. 714

Apparecchiatura elettrica
per comando temporizzato
di due elettrocompressori
Electrical equipment
for the timed control of
two electro-compressors
Art. 452 Hp 4-5,5
Art. 712 Hp 7,5-10 V.230
Art. 714 Hp 7,5-10 V.400

Valvola di ritegno
femmina-femmina
Non return valve
female-female
Art. 305 - 1"x1"
Art. 306 - 1"1/2x1"1/2



Art. 305
Art. 306



Art. 960
Art. 961
Art. 962
Art. 963

Salvamotore
Direct on line
starters
Art. 960 - 2,5/4 A
Art. 961 - 4/6,3 A
Art. 962 - 6,3/10 A
Art. 963 - 10/16 A

Valvola di ritegno
maschio-femmina
Non return valve male-female
Art. 304 - 3/4"x1/2"



Art. 304



Kit raccolta

- 1 - Abbacchiatore pneumatico
- 1 - Asta telescopica
 - 1,25 ÷ 1,95 mt (art.1100)
 - 1,85 ÷ 3,15 mt (art.1104)
- 1 - Tubo elastolan 20 mt

Harvesting kit

- 1 *Pneumatic olive harvester*
- 1 *Telescopic extension poles*
 - 1,25 ÷ 1,95 mt (art.1100)
 - 1,85 ÷ 3,15 mt (art.1104)
- 1 - *Polyurethane air hose 20 mt*



Kit raccolta + potatura

- 1 - Abbacchiatore pneumatico
- 1 - Asta telescopica
 - 1,25 ÷ 1,95 mt (art.1000)
 - 1,85 ÷ 3,15 mt (art.1105)
- 1 Forbice pneumatica per asta
- 1 Tubo elastolan 20 mt

Prunig + harvesting kit

- 1 *Pneumatic olive harvester*
- 1 *Telescopic extension poles*
 - 1,25 ÷ 1,95 mt (art.1000)
 - 1,85 ÷ 3,15 mt (art.1105)
- 1 *Pneumatic shear for poles*
- 1 *Polyurethane air hose 20 mt*



Art. 1007
 Abbacchiatore pneumatico
Pneumatic olive harvester

Tubo elastolan Ø 6x8 mm
 Polyurethane air hose Ø 6x8 mm
 Art. 1022 - 50 m
 Art. 1023 - 100 m



Art. 1022
Art. 1023



Art. 1206
 Rastrello singolo
Single harvester

Tubo elastolan Ø 8x10 mm
 Polyurethane air hose Ø 8x10 mm
 Art. 1027 - 50 m
 Art. 1028 - 100 m



Art. 1027
Art. 1028



Art. 1006
 Forbice pneumatica manuale
Manual pneumatic shear

Asta di prolunga telescopica
 Telescopic extension poles
 Art. 1004 - 1,25 ÷ 1,95 m
 Art. 1030 - 1,85 ÷ 3,15 m



Art. 1004
Art. 1030



Art. 1042
 Sega a catena pneumatica
 10" - 1/4"
Pneumatic chain saw
 10" - 1/4"

Forbice pneumatica per asta
Pneumatic shear



Art. 1051



Art. 1003
Art. 1020

Tubo elastolan Ø 6x8 mm
 completo di raccordi
 Polyurethane air hose Ø 6x8 mm
 with rapid connection
 Art. 1003 - 10 m
 Art. 1020 - 20 m

Tubo elastolan Ø 8x10 mm
 completo di raccordi
 Polyurethane air hose Ø 8x10 mm
 with rapid connection
 Art. 1025 - 10 m
 Art. 1026 - 20 m



Art. 1025
Art. 1026



Avvolgitubo manuale
Manual hose reels

Art. 1080 - Olio lubrificatore
Lubrificatore
Art. 1081 - Olio testata
Head oil



Kit staffa avvolgitubo
Kit hose reels support

Art. 1082 - Olio-diesel
Diesel-oil
Art. 1083 - Olio-benzina
Gasoline-oil



Kit guarnizioni per abbacchiatore
Kit harvester gasket

Adattatore forbice/asta
Adaptor shear/poles



Kit guarnizioni per forbici
Kit shear gasket

Attacco girevole forbice
Shear revolving coupling
Art. 1060 - Ø 6x8
Art. 1063 - Ø 8x10



Kit lame per forbici
Kit shear blade

Raccordo Y 1/4"
Connection Y 1/4"



Art. 1281 - Art. 1286



Tazza lubrificatore
Lubricator cup
Art. 1281 - 1/4"
Art. 1286 - 3/8"

Tazza filtro regolatore
Filter regulator cup
Art. 1280 - 1/4"
Art. 1285 - 3/8"

Art. 1280 Art. 1285



Art. 1062



Raccordo banjo 1/4"
Banjo connector 1/4"

Gruppo FRL MW
FRL group MW
Art. 1245 - 1/4"
Art. 1246 - 3/8"

Art. 1245 Art. 1246



Art. 1215 Art. 1216



Manometro glicerina
Glycerine pressure gauge
Art. 1215 - D. 40 1/8"
Art. 1216 - D. 50 1/4"

Valvola pilota
Pilot valve
Art. 1251 - 3/8"
Art. 1252 - 1/2"
Art. 1253 - 3/4"

Art. 1251 Art. 1252 Art. 1253



Art. 170



Rubinetto rapido 1/4"
Rapid cock 1/4"

Kit acceleratore benzina - Hp 4/6,5
Self throttle kit petrol - Hp 4/6,5

Art. 1065



Art. 460 Art. 461



Rubinetto rapido per tubo nylon
Rapid cock for nylon hose
Art. 460 6x8
Art. 461 8x10

Kit raccordi girevoli avvolgitubo 1/4"
Kit swivel connector hose reel 1/4"
Art. 1095 - Ø 6x8
Art. 1096 - Ø 8x10

Art. 1095 - Art. 1096

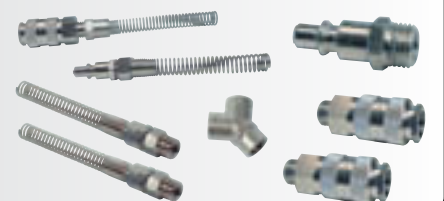

Art. 314 Art. 317 Art. 338 Art. 339



Valvola di sicurezza
Safety valve
Art. 314 - 1/4" - 10 bar
Art. 317 - 1/4" - 12 bar
Art. 338 - 3/8" - 11 bar
Art. 339 - 1/2" - 16 bar

Innesto rapido per tubo nylon
Rapid coupling for nylon hose
Art. 440 6x8
Art. 441 8x10

Art. 440 Art. 441

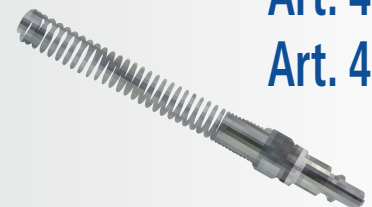

Art. 100



Attacco portagomma
a baionetta D. 6x14
Bayonet hose holder cap D. 6x14

Attacco portagomma
semplice D. 6
Hose holder cap D. 6

Art. 101



Art. 120



Raccordo di giunzione
con due dadi fresati 1/4"
*Double nipple with
two milled nuts 1/4"*

Innesto portagomma
per rubinetti rapidi 6x14
*Hose holder coupling
for rapid cock 6x14*

Art. 140

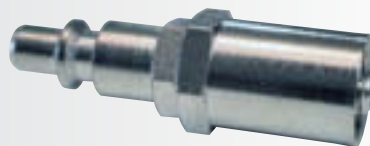

Art. 150



Innesto rapido 1/4"
Rapid coupling 1/4"

Innesto rapido con
attacco a baionetta
*Rapid coupling with
bayonet connector*

Art. 155

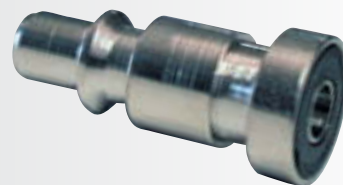

**Art. 1235 Art. 1236
Art. 1237**



Ruote pneumatiche
Pneumatic wheels
Art. 1235 - D. 260x85
Art. 1236 - D. 277x100
Art. 1237 - D. 325x117

Rubinetto di linea
con dado fresato
Line tap with milled nut

**Art. 622 - 3/8"
Art. 632 - 1/2"**



Art. 1220



Kit carrellaggio Agritech
Trolley kit Agritech

Rubinetto valvola a sfera
Ball valve line cock
Art. 642 - 1/2"
Art. 652 - 1"

**Art. 642
Art. 652**

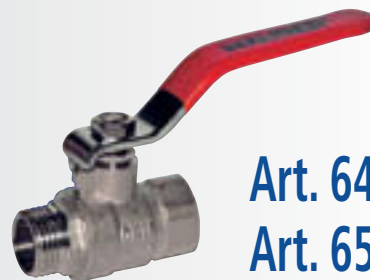

Art. 1230



Kit gancio traino Agritech
Draw-hook kit Agritech

Filtro 3/8"
Filter 3/8"

Art. 264



motralec

4 rue Lavoisier . ZA Lavoisier . 95223 HERBLAY CEDEX

Tel. : 01.39.97.65.10 / Fax. : 01.39.97.68.48

Demande de prix / e-mail : service-commercial@motralec.com

www.motralec.com