



water technology

motralec

4 rue Lavoisier . ZA Lavoisier . 95223 HERBLAY CEDEX
Tel. : 01.39.97.65.10 / Fax. : 01.39.97.68.48
Demande de prix / e-mail : service-commercial@motralec.com
www.motralec.com

nano**BOX**
Blue**BOX**
BOX**PRO**

Polyethylene lifting stations



water technology

IDEAL FOR COLLECTING WATER EXCLUSIVELY FROM DOMESTIC DRAINS, INCLUDING WASHING MACHINES, SHOWERS AND SINKS (NOT SUITED FOR WC'S).



IDEAL FOR COLLECTING AND LIFTING CLEAR, RAIN AND WASTE WATER FROM WASHING MACHINES, SINKS AND WC'S IN SYSTEMS INSTALLED AT A LOWER LEVEL THAN THE SEWER CONNECTION, SUCH AS GARAGES OR BASEMENTS.

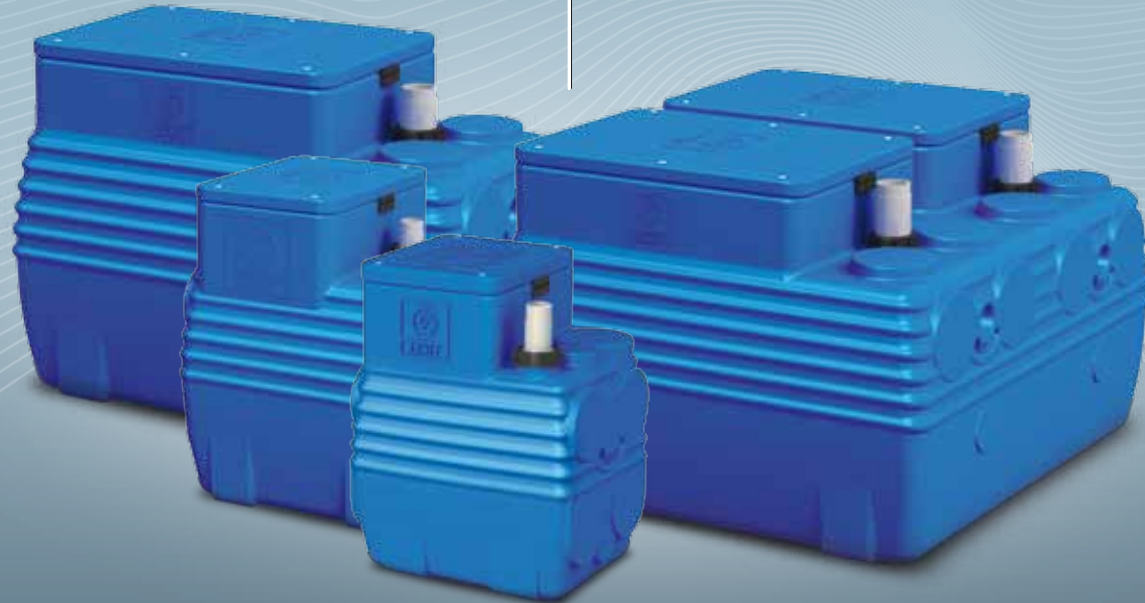

THE BOX PRO SERIES IS COMPOSED OF ROBUST MEDIUM DENSITY POLYETHYLENE LIFTING STATIONS, FOR USE IN LARGE CAPACITY RESIDENTIAL AND CIVIL APPLICATIONS.



nano**BOX**

blue**BOX**

BOX^{PRO}

nanoBOX BlueBOX BOXPRO

nanoBOX, BlueBOX and BOX PRO prefabricated lifting stations are an effective solution for collecting and pumping wastewater to the sewer system, when a gravity feed is not available.

They are mainly used in rural or hilly areas with low population density, without an extensive municipal sewer system.

Zenit offers a full range of models for any kind of application, from small domestic installations (**nanoBOX and BlueBOX**) to more complex systems for civil installations (**BOX PRO**).

Given their many advantages, lifting stations are today the best choice for a low cost, safe and eco-compatible solution.

A PROBLEM AND ITS SOLUTION

Polyethylene lifting stations can be adapted to any type of installation. Whether surface or underground, outdoors or indoors, they install quickly and easily with minimal construction work.

REDUCE COSTS

Compared with conventional concrete tanks, prefabricated tanks do not require maintenance and are more resistant to the chemical and mechanical stress induced by black water, as well as being advantageously priced.

WEIGHT DOES MATTER

Lifting stations made in a lightweight, highly resistant material like polyethylene have a lower shipping cost and are easier to handle and install, while sacrificing nothing in terms of reliability.

POWER CONSUMPTION, BUT ONLY WHEN NEEDED

Lifting stations are designed for rational, optimised electricity consumption, thanks to the use of pumps rated to match tank capacity, with automatic float switch control.

Polyethylene lifting station [33L]

nanoBOX

nanoBOX is a high quality polyethylene tank intended for collecting water exclusively from domestic drains, including washing machines, showers and sinks (not suited for WC's). The tank has a 33 L maximum capacity and is supplied with a Zenit Steel series submersible pump already installed. Thanks to its construction and small footprint, nanoBOX is very versatile and easy to install.



All product images are indicative only

Application

Ideal for collecting water exclusively from domestic drains, including washing machines, showers and sinks (not suited for WC's).

Features

- Max. water temperature (inlet)..... 35°C (for short periods up to 75°C)
- Free passage..... 10 mm
- Voltage and frequency 220/240V ~1, 50Hz
- Protection IP68
- Outlet..... DN32 (male thread)
- Inlet..... 1 x DN30, 1 x DN40
- Capacity 33 L
- Start Automatic with floatswitch
- Cable lenght 10 m

Installation diagram

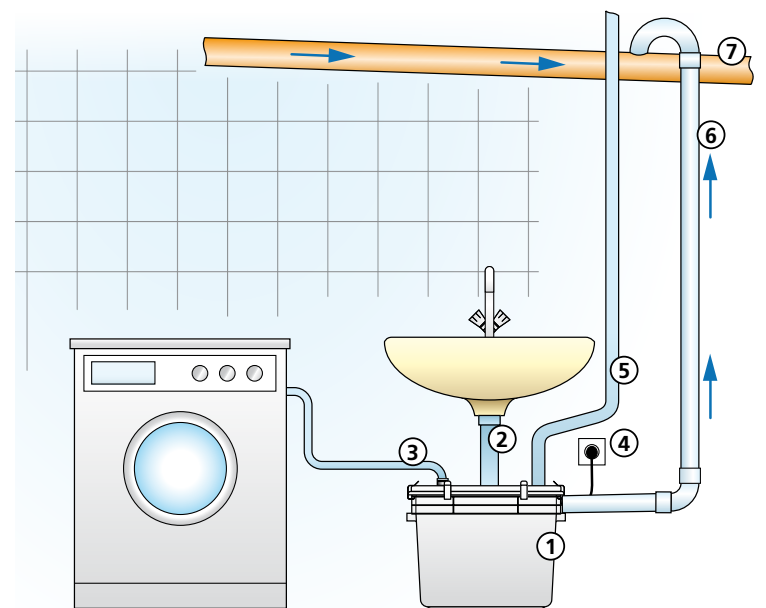

- ① nanoBOX
- ② Inlet from wash basin (with siphon)
- ③ Inlet from washing machine
- ④ Power supply
- ⑤ Breather pipe (filter no necessary)
- ⑥ Outlet pipe
- ⑦ Wastewater main pipework

Performances

	H (m)	Q					
		0.0	0.5	1.0	1.5	2.0	2.5
		0.0	30	60	90	120	150
		0.0	1.8	3.6	5.4	7.2	9.0
DR-Steel 25/2 M50	8.5	7.0	5.7	4.0	1.3		
DR-Steel 37/2 M50	13.6	11.6	9.5	7.0	4.5	1.9	

Technical data

	V	Phases	P2 (kW)	A	Rpm	Ø	Free passage
DR-Steel 25/2 M50	230	1	0.25	2.3	2900	G 1 1/4"	10 mm
DR-Steel 37/2 M50	230	1	0.37	3.1	2900	G 1 1/4"	10 mm

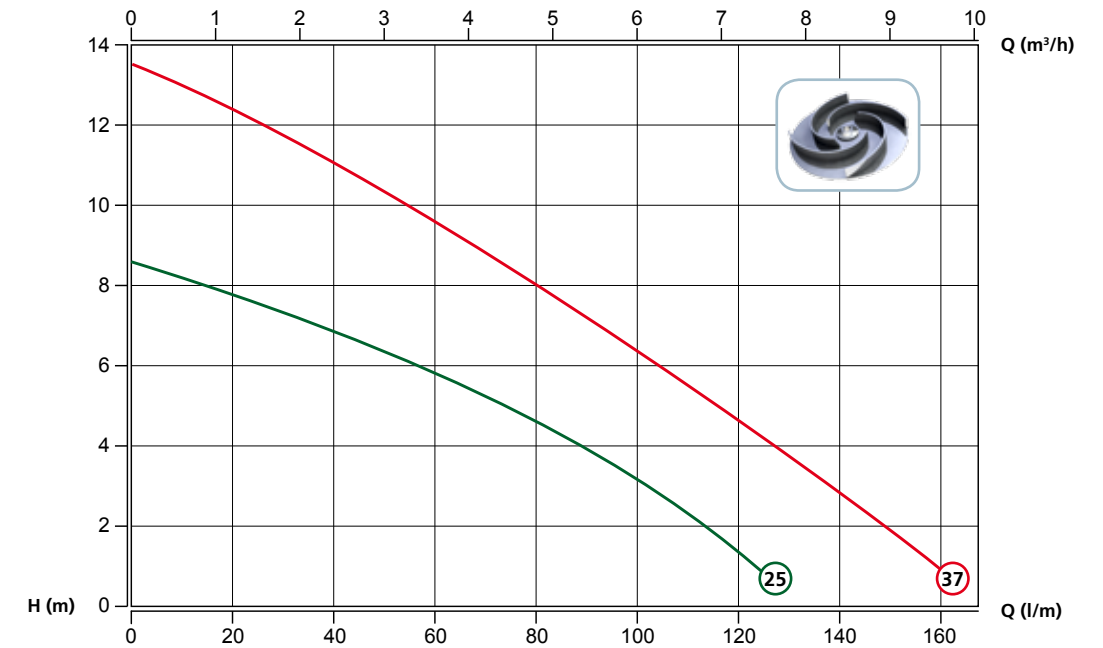

Dimensions

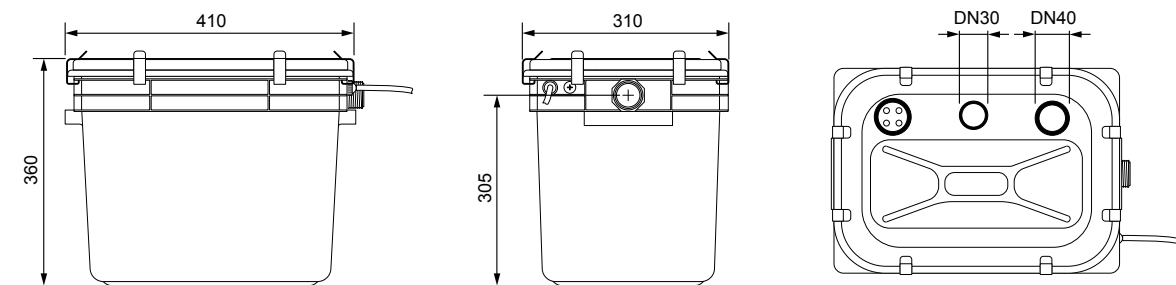

Dimensions in mm - Data without pump and accessories - All weights and dimensions are indicative only

Polyethylene lifting station [60 to 400L]

blue BOX

The **BlueBOX** series is composed of high quality rotary moulded polyethylene tanks for the collection of waste water and sewage.

The 90, 150 and 250 litre models are prepared for the installation of an electric pump and are suitable for small residential contexts.

The 400 litre version is intended for use in medium sized systems and anticipates the use of two electric pumps. Their particular shape is inspired by the Pininfarina design of the Series Blue submersible electric pumps.

BlueBOX, thanks to its construction characteristics and the plentiful accessories, it is extremely versatile and simple to install.

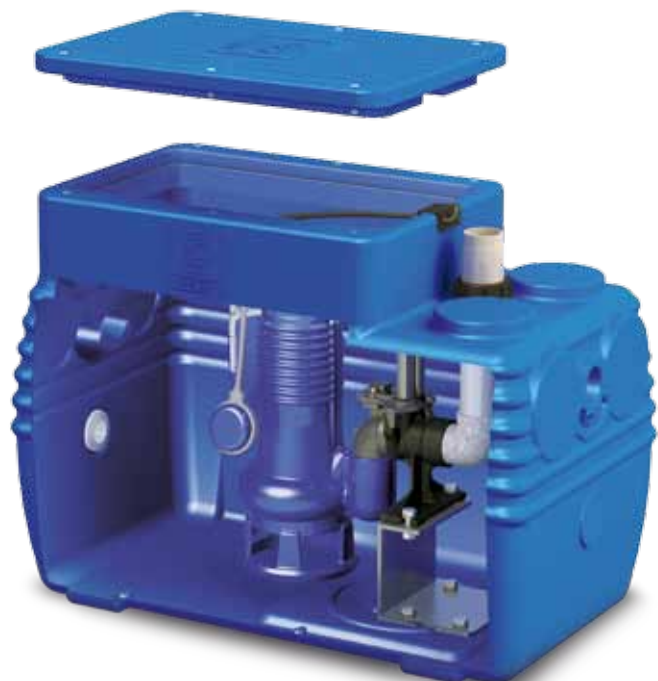

All product images are indicative only

Operation and Use

The collection tank collects the domestic waste water coming from discharges of any kind and any rainwater or infiltration water traps.

The pump installed inside the tank allows the water to be sent to the sewer. The cover and the connections for passing the pipes have gaskets to guarantee a perfect seal. **BlueBOX** is prepared for collection to the input, output and ventilation pipes on every side, enabling an optimal use even in small spaces.

Inside a grinding pump can be installed capable of chopping the extraneous bodies contained in the wastewater and sending them a considerable distance. In this way the liquid can also be made to pass through small diameter pipes, permitting a significant financial savings on the total cost of the installation.

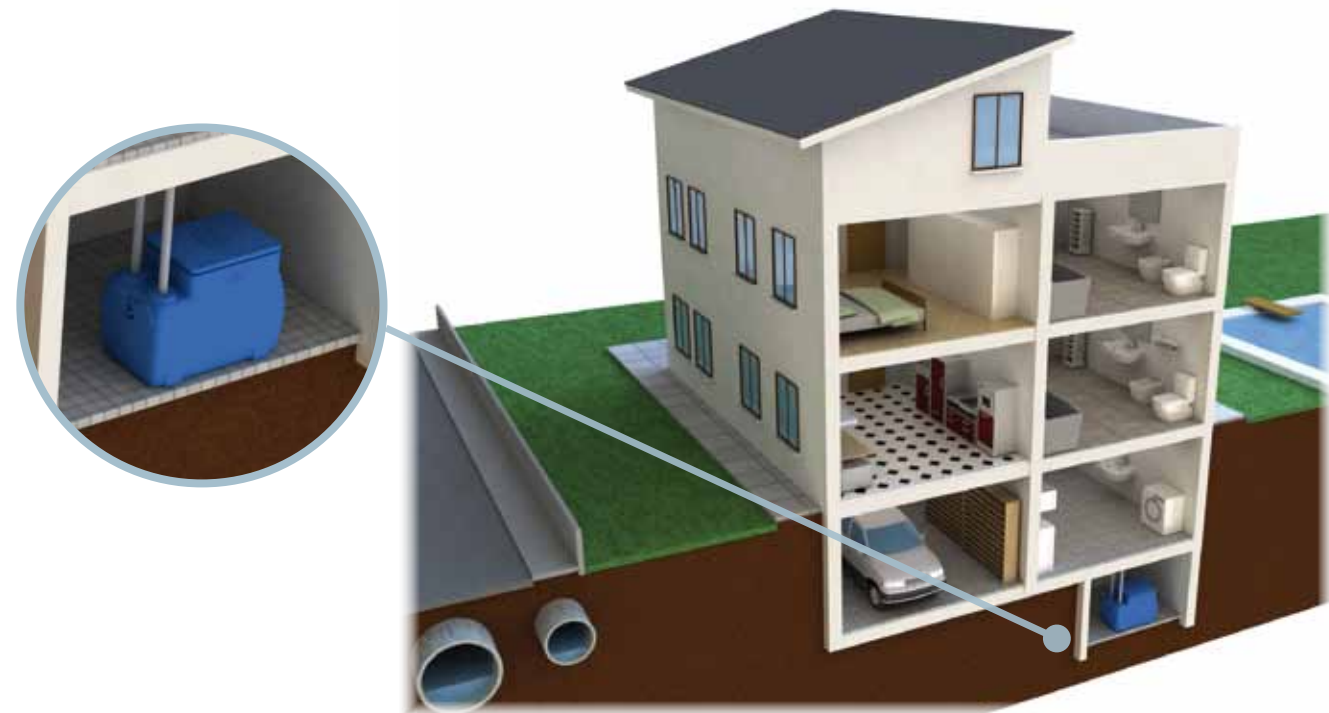

The BlueBOX range

BlueBOX stations are suitable for collecting and lifting clear, rain and waste water from washing machines, sinks and WCs in systems installed at a lower level than the sewer, in locations such as garages or basements.

The 90 and 150 litre models are compact and easy to install, making them ideal for civil and residential contexts. Thanks to the rich assortment of electrical and hydraulic accessories available, the 250 and 400 litre versions are suitable for industrial and residential installations.

* BlueBOX 90L

Capacity*	90 L
Dimensions (mm)	480x370x610
Nr. of pumps	1
Operation temperature	40°C (90°C short time)
Recommended pumps	DG Blue

Including: cable gland, PVC delivery pipe Ø 1½", emergency draining connector, gasket kit for inlet pipe 1xØ110, 1x75, 1x50 mm, nr.1 special support to reduce the float switch level, use and maintenance booklet. Overflow alarm level OPTIONAL.

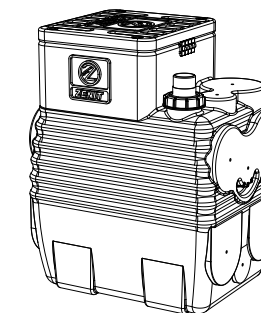

* BlueBOX 150L

Capacity	150 L
Dimensions (mm)	580x480x660
Nr. of pumps	1
Operation temperature	40°C (90°C short time)
Recommended pumps	DG Blue, DG BluePRO, GR BluePRO

Including: cable gland, PVC delivery pipe Ø 1½", emergency draining connector, gasket kit for inlet pipes 2xØ110, 1xØ75 and 1xØ50 mm, nr.1 special support to reduce the float switch level, use and maintenance booklet. Overflow alarm level OPTIONAL.

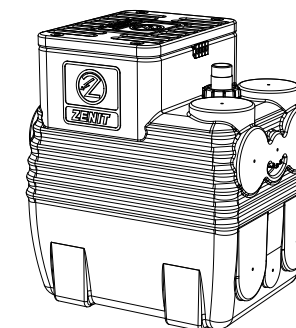

* BlueBOX 250L

Capacity	250 L
Dimensions (mm)	900x500x660
Nr. of pumps	1
Operation temperature	40°C (90°C short time)
Recommended pumps	DG Blue, DG BluePRO, GR BluePRO

Including: cable gland, nr. 2 gaskets pipe Ø110, nr. 1 gasket pipe Ø75 mm.

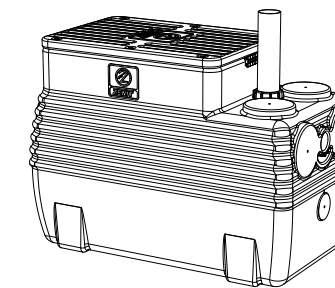

* BlueBOX 400L

Capacity	400 L
Dimensions (mm)	900x1.000x660
Nr. of pumps	2
Operation temperature	40°C (90°C short time)
Recommended pumps	DG Blue, DG BluePRO, GR BluePRO, DGO

Including: cable gland, nr. 4 gaskets pipe Ø110, nr. 2 gasket pipe Ø75 mm.

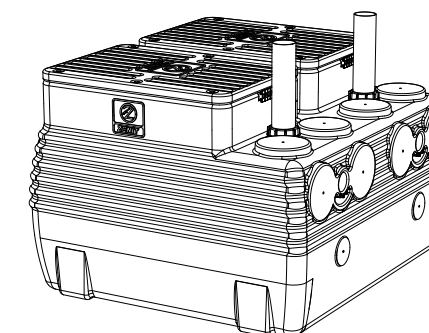

* Dimension in mm - Data without pump and accessories - All weights and dimensions are indicative only - The capacity is guideline and refers to the maximum volume capacity before the contents overflow from the tank.

How it's made

Technical features

- 90 And 150 litres version for one pump directly installed;
- 250 Litre version for one pump and 400 litre version for two pumps with coupling device or directly installed;
- Walk-over cover;
- O-ring seal between tank and cover;
- Simplified inlet, outlet and air venting pipe connections with seal;
- Integral lifting handles;
- Fitted for emergency emptying using a tap;
- PATENTED airtight cable gland allowing easy pump removal for any maintenance work;
- The side fins, in the middle of the tank, guarantee an excellent grip if the unit is installed in-floor (refer to relevant manual).



All product images are indicative only



1 Sturdy walk-over cover
The large top opening allows a backup pump to be used for emergency emptying, ensuring operations are simple and hygienic.



2 PATENTED modular cable gland system allowing the pump to be removed with no need to disconnect or extract the power supply cable (refer to relevant manual).



3 Guaranteed airtight thanks to "C" shaped double-lip NBR rubber seals. The seal allows the BlueBOX to be connected to the various pipelines quickly, solving the vibration problem.



4 Wastewater pipeline inlet ports also provided on sides.



5 Two integral handles for lifting and transport, for easy transfer even by hand.



6 Emergency drainage fitting located low down in the unit.

Recommended pumps

Additional configurations with submersible pumps from other Zenit families are possible. For further information, contact the Zenit Customer Service.

VORTEX IMPELLER	V	Phases	P2 (kW)	A	Rpm	Ø	Free passage	Suitable for BlueBOX			
								90L	150L	250L	400L
DG Blue 40/2/G40V A1BM/50	230	1	0.3	2.3	2900	G 1½"	40 mm	•			
DG Blue 50/2/G40V A1BM/50	230	1	0.37	2.8	2900	G 1½"	40 mm	•	•		
DG Blue 75/2/G40V A1BM/50	230	1	0.55	4.1	2900	G 1½"	40 mm	•	•		
DG Blue 100/2/G40V A1BM/50	230	1	0.74	5.6	2900	G 1½"	40 mm	•	•	•	•
DG BluePRO 50/2/G40V A1BM/50	230	1	0.37	2.8	2900	G 1½"	40 mm		•		
DG BluePRO 75/2/G40V A1BM/50	230	1	0.55	4.1	2900	G 1½"	40 mm		•		
DG BluePRO 100/2/G40V A1BM/50	230	1	0.74	5.6	2900	G 1½"	40 mm		•	•	•
DG BluePRO 150/2/G50V A1CM/50	230	1	1.1	7.5	2900	G 2"	50 mm			•	•
DG BluePRO 200/2/G50V A1CM/50	230	1	1.5	10.0	2900	G 2"	50 mm			•	•
DG BluePRO 50/2/G40V A1BT/50	400	3	0.37	1.15	2900	G 1½"	40 mm		•		
DG BluePRO 75/2/G40V A1BT/50	400	3	0.55	1.6	2900	G 1½"	40 mm		•		
DG BluePRO 100/2/G40V A1BT/50	400	3	0.74	2.15	2900	G 1½"	40 mm		•	•	•
DG BluePRO 150/2/G50V A1CT/50	400	3	1.1	3.2	2900	G 2"	50 mm			•	•
DG BluePRO 200/2/G50V A1CT/50	400	3	1.5	4.3	2900	G 2"	50 mm			•	•
DGO 150/2/G65V A1CM/50	230	1	1.1	8.2	2900	G 2½"	65 mm				•
DGO 200/2/G65V A1CM/50	230	1	1.5	9.9	2900	G 2½"	65 mm				•
DGO 150/2/G65V A1CT/50	400	3	1.1	2.7	2900	G 2½"	65 mm				•
DGO 200/2/G65V A1CT/50	400	3	1.5	3.6	2900	G 2½"	65 mm				•

l/s	0	2	4	6	8	10	12
l/min	0	120	240	360	480	600	720
m³/h	0	7.2	14.4	21.6	28.8	36.0	43.2

DGBLUE 40/2/G40V A1BM/50	6.0	4.0	1.7				
DGBLUE 50/2/G40V A1BM/50	7.6	5.5	2.9				
DGBLUE 75/2/G40V A1BM/50	10.1	8.5	5.7	2.6			
DGBLUE 100/2/G40V A1BM/50	11.6	10.2	7.6	4.3			
DG BluePRO 50/2/G40V A1BM(T)/50	7.0	4.9	2.4				
DG BluePRO 75/2/G40V A1BM(T)/50	10.2	8.0	5.5	2.6			
DG BluePRO 100/2/G40V A1BM(T)/50	11.4	9.8	7.4	4.4			
DG BluePRO 150/2/G50V A1CM(T)/50	12.3	10.7	8.8	6.5	4.4	2.4	
DG BluePRO 200/2/G50V A1CM(T)/50	15.3	13.7	11.7	9.4	7.1	4.7	2.5
DGO 150/2/G65V A1CM(T)/50	8.0	7.2	6.1	4.7	3.0		
DGO 200/2/G65V A1CM(T)/50	9.7	8.8	7.7	6.3	4.7	3.0	

GRINDERS	V	Phases	P2 (kW)	A	Rpm	Ø	Suitable for BlueBOX			
							90L	150L	250L	400L
GR BluePRO 100/2/G40H A1CM/50	230	1	0.74	5.5	2900	G 1½"-DN32 PN6	•	•	•	•
GR BluePRO 150/2/G40H A1CM/50	230	1	1.1	7.5	2900	G 1½"-DN32 PN6			•	•
GR BluePRO 200/2/G40H A1CM/50	230	1	1.5	10.0	2900	G 1½"-DN32 PN6			•	•
GR BluePRO 100/2/G40H A1CT/50	400	3	0.74	2.7	2900	G 1½"-DN32 PN6	•	•	•	•
GR BluePRO 150/2/G40H A1CT/50	400	3	1.1	3.2	2900	G 1½"-DN32 PN6			•	•
GR BluePRO 200/2/G40H A1CT/50	400	3	1.5	4.3	2900	G 1½"-DN32 PN6			•	•

l/s	0	1	2	3	4	5
l/min	0	60	120	180	240	300
m³/h	0	3.6	7.2	10.8	14.4	18.0

GR BluePRO 100/2/G40H A1CM(T)/50	18.0	16.4	14.4	11.5	6.9	
GR BluePRO 150/2/G40H A1CM(T)/50	21.1	19.6	17.9	15.1	10.4	3.0
GR BluePRO 200/2/G40H A1CM(T)/50	27.0	25.6	23.6	20.7	16.1	9.3

Types of installation

BlueBOX lifting stations can be installed on-floor or in-floor.

They are prefitted for use with Zenit pumps with vortex impeller or with grinding systems, which must be ordered separately depending on the customer's specific requirements.

The large number of intake and outlet pipeline fittings allow optimal installation even on existing plants.

What's more the many hydraulic and electric accessories make BlueBOX lifting stations convenient to install and use.

BlueBOX 90 - 150

Installations

In view of their small size, 90 and 150 litre models can be installed coupled directly to the pump. The bottom of the BlueBOX is shaped to hold the pump in position without the aid of additional accessories.

DG Blue pumps with vortex impeller or GRBlue models with grinder can be used.

With grinders, an ordinary threaded 90° bend must be used to change the direction of the delivery line.

The PVC outlet pipe connected to the pump has a coupling which allows the pump to be easily separated from the pump for any maintenance requirements, without disconnecting the pipelines from the lifting stations.



All product images are indicative only

Electrical accessories

In these models, the use of pumps with start/stop float-switch is recommended.

This makes installation simple and inexpensive.

An optional float switch with an overflow alarm function, for connection to an electrical control panel, can be used if required.

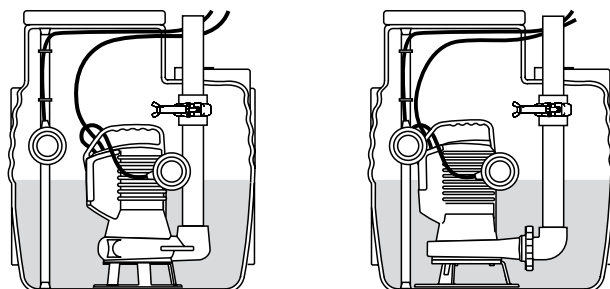

BlueBOX 250 - 400

Installations

Fixed installation

Ideal installation for pump with vertical delivery outlet up to 2½".

The pump rests on the bottom of the tank. The specially shaped bottom keeps the pump in the correct position.

A ball check valve and/or a gate valve can be connected to the end of the delivery pipeline.

Permanent installation is definitely the simplest and most economical.

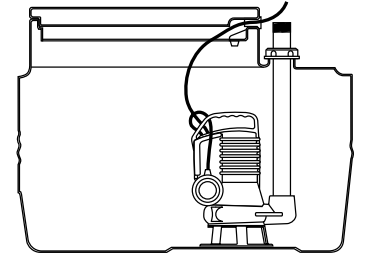

Installation with bottom coupling device (DAC)

Installation with the bottom coupling device allows the pump to be raised and repositioned easily, with no need to empty the tank.

Vertical delivery pumps can be installed using a special kit for horizontal DAC units.

This is a versatile installation option which simplifies pump maintenance or replacement.

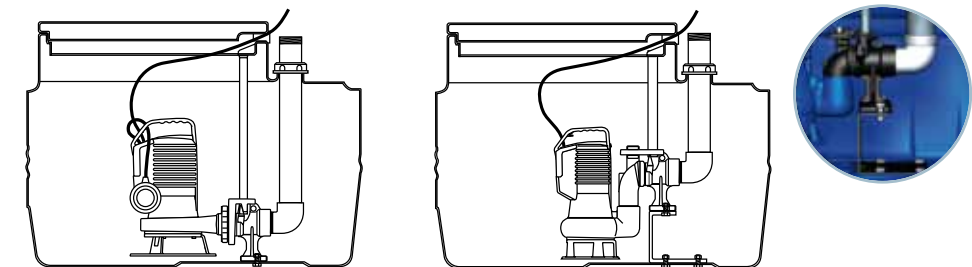

Installation with bottom coupling device (DAC) and ball valve (VAP)

This special, compact accessory provides all the benefits of an ordinary DAC, and also, thanks to an integral venting valve, it prevents air pockets from forming inside the pump body if the unit runs dry.

Thanks to this feature, a special ball check valve can be directly connected to the outlet of the DAC inside the BlueBOX, ensuring compact size and removing installation constraints.

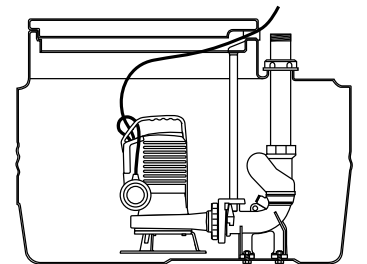

Electrical accessories

With integral float switch

In the event of use of pumps with float switch, BlueBOX lifting stations can be used with no further electric accessories. The float switch starts and stops the pump depending on the level reached.

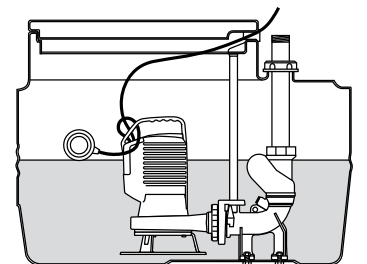

Without integral float switch

In the event of use of pumps without float switch, the BlueBOX lifting station must be equipped with minimum and maximum level float switches, and alarm float switch if required.

The electrical panel complete with all features required for operation of one or two pumps (BlueBOX 400L) and accessories such as alternating control device or alarm with buzzer and light is available on request.

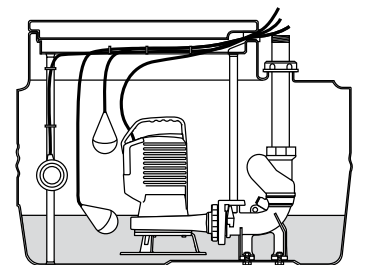

How to install it

Installing a **BlueBOX** lifting station could not be easier. It is supplied partially assembled to speed up installation by the customer. A large number of construction features simplify installation, and the accessories supplied allow the system to be optimised in all conditions.



1

The **BlueBOX** tank can be installed on-floor or in-floor. Inlet and output pipeline fittings are provided on three sides, allowing installation to be optimised to requirements.



2

Before the unit is actually placed in position, holes are drilled in the sides using a flared grinding tool to take the seals and then the pipes in the chosen positions.



3

To ensure perfect sealing, the double lip seal provided is fitted. No additional sealants are required, making installation an extremely quick procedure.



4

Once our **BlueBOX** has been placed in the installation position, the wastewater inlet and ventilation pipes are fitted.



5

The next step is to install the pump, which will certainly be easier if a **BlueBOX** with DAC was chosen. In this case, the flange provided has only to be slid along the guide tubes to achieve perfect coupling to the body of the DAC. The **BlueBOX** contains an accessory that can be fitted to allow emptying in emergencies through the drainage hole low down in the unit.



6

The electrical cables are passed through special patented rubber cable glands that ensure a perfectly airtight seal. Before fitting the cable, perforate the chosen cable glands with a sharp tool, but leave the others intact to keep liquids or smells inside the unit.



7

Once installation is complete and operation of the pump and its float switches has been checked, the cover can be screwed into place. The cover is walk-over but will not support vehicles.



8

The **BlueBOX** lifting station is ready for use. The vast range of plumbing and electrical accessories covers all installation requirements.

Overall dimensions and weights*

BlueBOX 90L

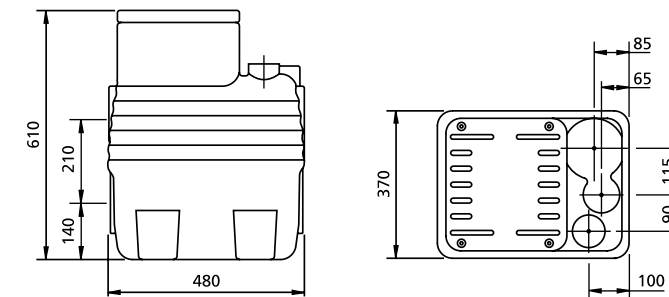

Inlet	9 x Ø 110
	1 x Ø 75
Outlet	1 x Ø 1½" - 2"
Weight	kg 9

BlueBOX 150L

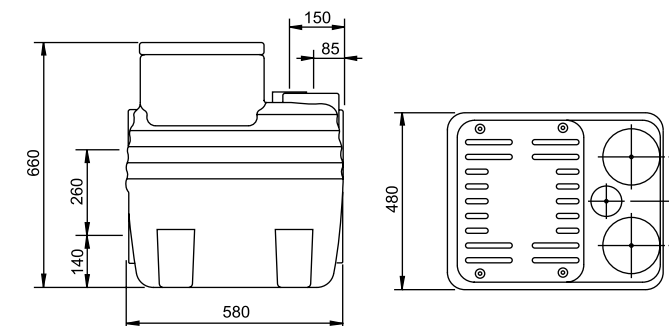

Inlet	10 x Ø 75 or 110
Outlet	1 x Ø 1½" - 2"
Weight	kg 11

BlueBOX 250L

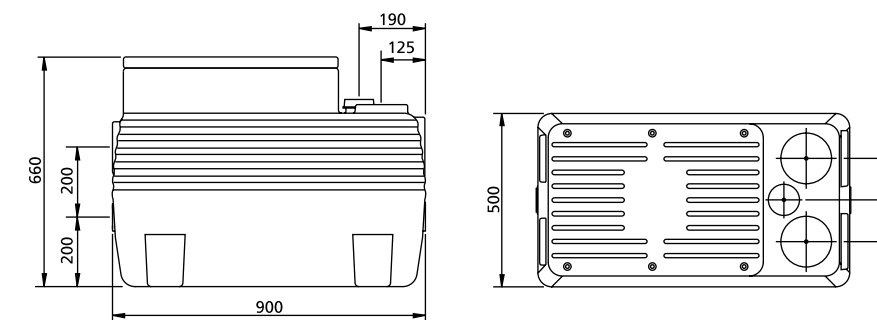

Inlet	10 x Ø 75 or 110
Outlet	1 x Ø 1½" - 2"
Weight	kg 15

BlueBOX 400L

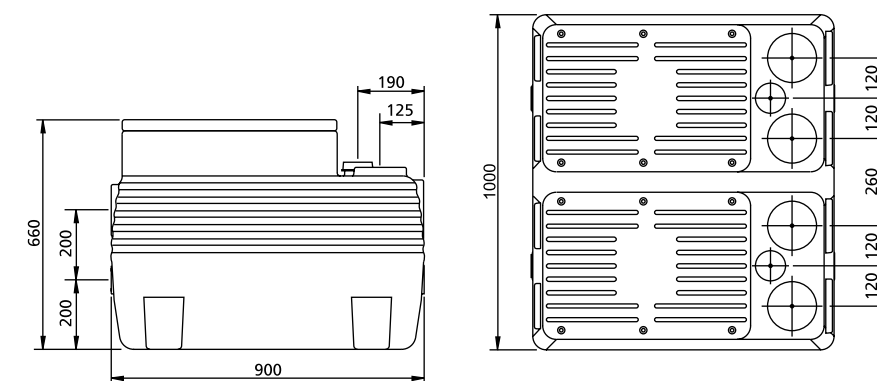

Inlet	20 x Ø 75 or 110
Outlet	2 x Ø 1½" ÷ 2½"
Weight	kg 31

*Dimension in mm - Data without pump and accessories - All weights and dimensions are indicative only

Polyethylene lifting station [1.000 to 18.000L]

BOX PRO

The **BOX PRO** series is composed of pumping stations in medium density sturdy polyethylene, suitable for installations in large scale civil and residential establishments.

They are generally installed in areas where gravity drainage is not available to the waste water services. The below ground level installation facilitates collection of waste and drainage water.

Pumping stations are an engineered design so that the chamber can resist the ground and water pressures when installed. Hygienically designed with smooth internal walls and an optimum collection area which aids the removal of the effluent to avoid smells and septicity ensuring that the **BOX PRO** System gives the best possible performance.



All product images are indicative only

Operation and Use

The **BOX PRO** pumping stations can be used with one or two submersible electric pumps with vortex, channel or grinder impellers. The pumps are installed via an auto coupling device at the bottom which permits the rapid recovery of the electric pump on to the surface, without needing to enter or empty the chamber.

Every station has 3 inlet connections for the entry of the waste water, there are also 2 high level cable inlet connections for pump and float cables. A metal access cover(s) are provide to suite pedestrian or highway applications.

The operation can be automated thanks to the control system using floats switches which also includes a high level alarm for an even more secure system. There is an isolation gate valve on the S & J Types that uses a special key which is included, allowing the control of the discharge gate through an inspection window from cover level, without entering the chamber.



The BOX PRO range

The BOX PRO stations are recommended for the collection and pumping of waste and drainage waters.

*M Type

This chamber is ideal for small flows from a single dwelling and where excavation depth is limited.

Capacity (liters)	1.000
Dimensions (mm)	Ø1.016 - h1.224
Weight (Kg)	85 ÷ 175
Nr. of pumps	1/2
Operation temperature	40°C (90°C short time)
Recommended pumps	DRO, DGO, SMI, DGI, GRBluePRO, GRI, GRE

Including: nr. 3 inlet pipe gaskets Ø160mm, nr. 2 electrical cable pipes gaskets Ø110mm, galvanized hook for pump lifting chain, float switch hook support, ground connection net, single or double DN 50 ABS outlet pipe or DN 80-100-150 ductile iron pipe, coupling foot for bottom installation with galvanized guidelines, non-return ball check valve.

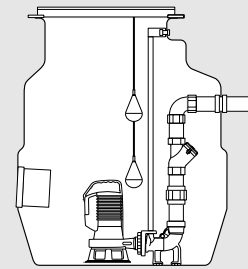

*V Type

The V chamber is the most popular size for use in a single dwelling, toilet block, or small office serving up to 10 people.

Capacity (liters)	2.000
Dimensions (mm)	Ø1.016 - h2.310
Weight (Kg)	134 ÷ 235
Nr. of pumps	1/2
Operation temperature	40°C (90°C short time)
Recommended pumps	DRO, DGO, SMI, DGI, GRBluePRO, GRI, GRE

Including: nr. 3 inlet pipe gaskets Ø160mm, nr. 2 electrical cable pipes gaskets Ø110mm, galvanized hook for pump lifting chain, float switch hook support, ground connection net, single or double DN 50 ABS outlet pipe or DN 80-100-150 ductile iron pipe, coupling foot for bottom installation with galvanized guidelines, non-return ball check valve.

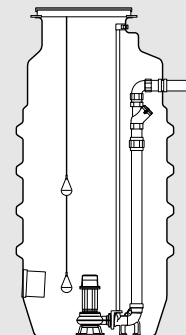

*S Type

The S chamber for two pumps, is suitable for small housing and industrial/commercial developments, restaurants, small hotels / nursing homes, caravan sites. Larger capacities are available to special order.

Capacity (liters)	4.000 ÷ 9.500
Dimensions (mm)	Ø1.624 - h2.015, 3.000, 4.000, 4.500
Weight (Kg)	242 ÷ 839
Nr. of pumps	2
Operation temperature	40°C (90°C short time)
Recommended pumps	DRO, DGO, DGN, DGP, MAN, GRBluePRO, GRI, GRE, GRP, GRN, APN, APP, SMP

Including: nr. 3 inlet pipe gaskets Ø160mm, nr. 2 electrical cable pipes gaskets Ø110mm, galvanized hook for pump lifting chain, float switch hook support, ground connection net, single or double DN 50 ABS outlet pipe or DN 80-100-150 ductile iron pipe, coupling foot for bottom installation with galvanized guidelines, non-return ball check valve.

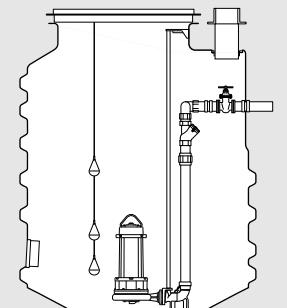

*J Type

The 2-pump J station is the selection for larger housing developments, hotels, hospitals, sewage works.

Capacity (liters)	10.000 ÷ 18.000
Dimensions (mm)	Ø2.246 - h2.520, 3.500, 4.500
Weight (Kg)	422 ÷ 1508
Nr. of pumps	2
Operation temperature	40°C (90°C short time)
Recommended pumps	DRO, DGO, DGN, DGP, MAN, GRBluePRO, GRI, GRE, GRP, GRN, APN, APP, SMP

Including: nr. 3 inlet pipe gaskets Ø160mm, nr. 2 electrical cable pipes gaskets Ø110mm, galvanized hook for pump lifting chain, float switch hook support, ground connection net, single or double DN 50 ABS outlet pipe or DN 80-100-150 ductile iron pipe, coupling foot for bottom installation with galvanized guidelines, non-return ball check valve.

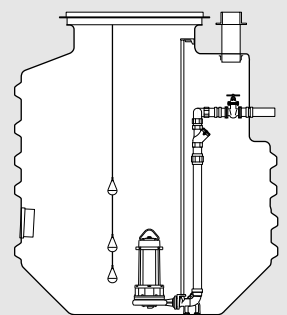

How it's made

Technical features

- Installation using coupling device at the bottom
- Start/stop system and overflow prevention alarm using floats
- ABS or ductile iron with cement internal coating discharge pipes
- Double non-return valve (only on dual stations)
- Gate valve which can be controlled from outside
- Metal cover for pedestrian and vehicle loading
- Totally recyclable
- Equipotential bonding of all chambers



Inlet branch assembly

A fully adjustable external inlet stack assembly for single/multiple pipe work connections effectively directing all waste entering the systems to the base of the internal pumps, therefore reducing turbulence, odour problems whilst allowing full flexibility to overcome inlet pipe work level deviations and ensuring the flow of solid waste into the chamber preventing blockages.



All product images are indicative only

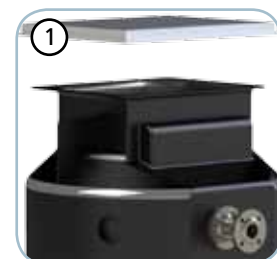

1 Made in "medium density" polyethylene with enhanced thickness, more resistant for construction site and low temperatures.



2 Installation of the electric pump with level coupling fastened to the bottom using screws with hermetically sealing gasket and steel reinforcement bars.



3 Preparation for three waste water inlet pipes Ø160mm with rapid fastening using NBR gaskets without the use of sealant products.

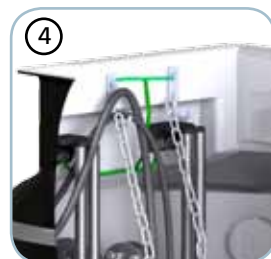

4 Grounding of all metallic element inside the lift station by equipotential bonding.

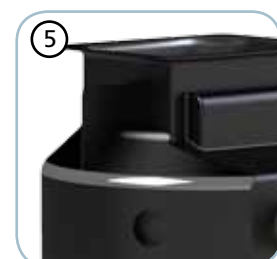

5 Two Ø110 mm outlets for the electric cables which facilitates the connection operation to the panel of the electric pumps, float switch and any ultrasound probes



6 DN50 discharge pipe in ABS and DN80-100-150 realized in ductile iron coated inside with cement mortar in accordance with regulation EN 545:2002 to guarantee a greater resistance to mechanical wear and corrosion.

Recommended pumps

Additional configurations are possible with submersible pumps of other Zenit lines (check in advance the compatibility of the discharge opening with the coupling device). For further information, contact the Zenit Customer Service.

VORTEX IMPELLER	V	Phases	P1 (kW)	P2 (kW)	A	Rpm	Ø	Free passage	Suitable for BOX PRO			
									M	V	S	J
DGO 50/2/G50H A1CM/50	230	1	-	0.37	2.9	2900	G 2"- DN50 PN10-16	40 mm	•	•	•	•
DGO 50/2/G50H A1CT/50	400	3	-	0.37	1.1	2900	G 2"- DN50 PN10-16	40 mm	•	•	•	•
DGO 75/2/G50H A1CM/50	230	1	-	0.55	3.9	2900	G 2"- DN50 PN10-16	40 mm	•	•	•	•
DGO 75/2/G50H A1CT/50	400	3	-	0.55	1.4	2900	G 2"- DN50 PN10-16	40 mm	•	•	•	•
DGO 100/2/G50H A0CM/50	230	1	-	0.88	6.5	2900	G 2"- DN50 PN10-16	50 mm	•	•	•	•
DGO 100/2/G50H A0CT/50	400	3	-	0.88	2.3	2900	G 2"- DN50 PN10-16	50 mm	•	•	•	•
DGO 150/2/G50H A0CM/50	230	1	-	1.1	8.2	2900	G 2"- DN50 PN10-16	50 mm	•	•	•	•
DGO 150/2/G50H A0CT/50	400	3	-	1.1	2.6	2900	G 2"- DN50 PN10-16	50 mm	•	•	•	•
DGO 200/2/G50H A0CM/50	230	1	-	1.5	9.3	2900	G 2"- DN50 PN10-16	50 mm	•	•	•	•
DGO 200/2/G50H A0CT/50	400	3	-	1.5	3.6	2900	G 2"- DN50 PN10-16	50 mm	•	•	•	•
DGO 200/2/80 A1CM/50	230	1	-	1.7	11.2	2900	DN80 PN10-16	80 mm	•	•	•	•
DGO 200/2/80 A1CT/50	400	3	-	1.7	3.9	2900	DN80 PN10-16	80 mm	•	•	•	•
DGO 100/4/G50H A0CM/50	230	1	-	0.7	5.7	1450	G 2" DN50 PN10	45 mm	•	•	•	•
DGO 100/4/G50H A0CT/50	400	3	-	0.7	2.2	1450	G 2" DN50 PN10	45 mm	•	•	•	•
DGO 150/4/80 A0CM/50	230	1	-	0.9	7.5	1450	DN80 PN10-16	60 mm	•	•	•	•
DGO 150/4/80 A0CT/50	400	3	-	0.9	2.8	1450	DN80 PN10-16	60 mm	•	•	•	•
DGI 200/2/80 A0CM/50	230	1	-	1.5	9.3	2900	DN80 PN10	50 mm	•	•	•	•
DGI 200/2/80 A0CT/50	400	3	-	1.5	3.5	2900	DN80 PN10	50 mm	•	•	•	•
DGI 100/4/80 A0CM/50	230	1	-	0.74	5.5	1450	DN80 PN10-16	80 mm	•	•	•	•
DGI 100/4/80 A0CT/50	400	3	-	0.74	2.3	1450	DN80 PN10-16	80 mm	•	•	•	•
DGN 250/2/80 A1DM/50	230	1	2.8	1.8	12.5	2900	DN80 PN10-16	80 mm			•	•
DGN 250/2/80 A1DT/50	400	3	2.5	1.8	4.3	2900	DN80 PN10-16	80 mm			•	•
DGN 400/2/80 A1FT/50	400	3	4.0	3	6.7	2900	DN80 PN10-16	80 mm			•	•
DGN 550/2/80 A1FT/50	400	3	5.0	4.1	8.7	2900	DN80 PN10-16	80 mm			•	•
DGN 200/4/80 A1DT/50	400	3	2.0	1.5	4.1	1450	DN80 PN10-16	80 mm			•	•
DGN 300/4/80 A1FT/50	400	3	2.9	2.2	5.8	1450	DN80 PN10-16	80 mm			•	•
DGN 400/4/80 A1FT/50	400	3	3.7	3	7.3	1450	DN80 PN10-16	80 mm			•	•
DGN 200/4/100 A1DT/50	400	3	2.0	1.5	4.1	1450	DN100 PN10-16	100 mm			•	•
DGN 300/4/100 A1FT/50	400	3	2.9	2.2	5.8	1450	DN100 PN10-16	100 mm			•	•
DGN 400/4/100 A1FT/50	400	3	3.7	3	7.3	1450	DN100 PN10-16	100 mm			•	•
DGP 550/4/80 A0GT/50	400	3	5.9	4.6	10.1	1450	DN80 PN10-16	60 mm			•	•
DGP 750/4/80 A0HT/50	400	3	8.6	6.5	14.9	1450	DN80 PN10-16	60 mm			•	•
DGP 1000/4/80 A0HT/50	400	3	11.5	8.9	20	1450	DN80 PN10-16	60 mm			•	•
DGP 550/4/100 A0GT/50	400	3	5.9	4.6	10.1	1450	DN100 PN10-16	80 mm			•	•
DGP 750/4/100 A0HT/50	400	3	8.6	6.5	14.9	1450	DN100 PN10-16	85 mm			•	•
DGP 1000/4/100 A0HT/50	400	3	11.5	8.9	20	1450	DN100 PN10-16	85 mm			•	•
DGP 1500/4/100 A0IT/50	400	3	15.8	13.6	28.2	1450	DN100 PN10-16	80 mm			•	•

OPEN MULTI CHANNEL IMPELLER	V	Phases	P1 (kW)	P2 (kW)	A	Rpm	Ø	Free passage	Suitable for BOX PRO			
									M	V	S	J
DRO 50/2/G32V A0CM/50	230	1	-	0.37	2.9	2900	G 1 1/4"	15 mm	•	•	•	•
DRO 50/2/G32V A0CT/50	400	3	-	0.37	1.1	2900	G 1 1/4"	15 mm	•	•	•	•
DRO 75/2/G32V A0CM/50	230	1	-	0.55	3.9	2900	G 1 1/4"	15 mm	•	•	•	•
DRO 75/2/G32V A0CT/50	400	3	-	0.55	1.4	2900	G 1 1/4"	15 mm	•	•	•	•
DRO 100/2/G50V A0CM/50	230	1	-	0.88	6.5	2900	G 2"	15 mm	•	•	•	•
DRO 100/2/G50V A0CT/50	400	3	-	0.88	2.3	2900	G 2"	15 mm	•	•	•	•
DRO 150/2/G50V A0CM/50	230	1	-	1.1	8.2	2900	G 2"	15 mm	•	•	•	•
DRO 150/2/G50V A0CT/50	400	3	-	1.1	2.7	2900	G 2"	15 mm	•	•	•	•
DRO 200/2/G50V A0CM/50	230	1	-	1.5	9.3	2900	G 2"	15 mm	•	•	•	•
DRO 200/2/G50V A0CT/50	400	3	-	1.5	3.5	2900	G 2"	15 mm	•	•	•	•

OPEN MULTI CHANNEL IMPELLER	V	Phases	P1 (kW)	P2 (kW)	A	Rpm	Ø	Free passage	Suitable for BOX PRO			
									M	V	S	J
DRO 100/2/G50H A0CM/50	230	1	-	0.88	6.5	2900	G 2"- DN50 PN10-16	15 mm	•	•	•	•
DRO 100/2/G50H A0CT/50	400	3	-	0.88	2.3	2900	G 2"- DN50 PN10-16	15 mm	•	•	•	•
DRO 150/2/G50H A0CM/50	230	1	-	1.1	8.2	2900	G 2"- DN50 PN10-16	15 mm	•	•	•	•
DRO 150/2/G50H A0CT/50	400	3	-	1.1	2.7	2900	G 2"- DN50 PN10-16	15 mm	•	•	•	•
DRO 200/2/G50H A0CM/50	230	1	-	1.5	9.3	2900	G 2"- DN50 PN10-16	15 mm	•	•	•	•
DRO 200/2/G50H A0CT/50	400	3	-	1.5	3.5	2900	G 2"- DN50 PN10-16	15 mm	•	•	•	•

OPEN SINGLE CHANNEL IMPELLER	V	Phases	P1 (kW)	P2 (kW)	A	Rpm	Ø	Free passage	Suitable for BOX PRO			
									M	V	S	J
MAN 250/2/80 A1DM/50	230	1	2.8	1.8	12.5	2900	DN80 PN10-16	40 mm			•	•
MAN 250/2/80 A1DT/50	400	3	2.5	1.8	4.3	2900	DN80 PN10-16	40 mm			•	•
MAN 300/2/80 A1DT/50	400	3	2.9	2.2	5.1	2900	DN80 PN10-16	40 mm			•	•
MAN 400/2/80 A1FT/50	400	3	4.0	3	6.7	2900	DN80 PN10-16	40 mm			•	•
MAN 550/2/80 A1FT/50	400	3	5.0	4.1	8.7	2900	DN80 PN10-16	45 mm			•	•
MAN 400/2/100 A1FT/50	400	3	4.0	3	6.7	2900	DN100 PN10-16	50 mm			•	•
MAN 550/2/100 A1FT/50	400	3	5.0	4.1	8.7	2900	DN100 PN10-16	50 mm			•	•
MAN 200/4/80 A1DT/50	400	3	2	1.5	4.1	1450	DN80 PN10-16	80 mm			•	•
MAN 300/4/80 A1FT/50	400	3	2.9	2.2	5.8	1450	DN80 PN10-16	80 mm			•	•
MAN 300/4/100 A1FT/50	400	3	2.9	2.2	5.8	1450	DN100 PN10-16	80 mm			•	•
MAN 400/4/100 A1FT/50	400	3	3.7	3	7.3	1450	DN100 PN10-16	80 mm			•	•

CLOSED SINGLE CHANNEL IMPELLER	V	Phases	P1 (kW)	P2 (kW)	A	Rpm	Ø	Free passage	Suitable for BOX PRO			
									M	V	S	J
SMI 200/2/G50H A0CM/50	230	1	1.9	1.5	9.9	2900	G 2" DN80 PN10	50 mm	•	•		
SMI 200/2/G50H A0CT/50	400	3	2.0	1.5	3.5	2900	G 2" DN80 PN10	50 mm	•	•		
SMP 550/2/80 A0GT/50	400	3	6.8	5.5	11.5	2900	DN80 PN10-16	53 mm			•	•
SMP 750/2/80 A0HT/50	400	3	8.9	7.2	14.5	2900	DN80 PN10-16	55x65 mm			•	•
SMP 1000/2/80 A0HT/50	400	3	12.4	10	19.8	2900	DN80 PN10-16	55x65 mm			•	•
SMP 400/4/100 A0FT/50	400	3	4.1	3	7.9	1450	DN100 PN10-16	75x100 mm			•	•
SMP 750/4/100 A0HT/50	400	3	8.6	6.5	14.9	1450	DN100 PN10-16	80x100 mm			•	•
SMP 1000/4/100 A0HT/50	400	3	11.5	8.9	20	1450	DN100 PN10-16	80x100 mm			•	•
SMP 400/4/150 A0FT/50	400	3	4.1	3	7.9	1450	DN150 PN10-16	75x100 mm			•	•
SMP 750/4/150 A0HT/50	400	3	8.6	6.5	14.9	1450	DN150 PN10-16	80x100 mm			•	•
SMP 1000/4/150 A0HT/50	400	3	11.5	8.9	20	1450	DN150 PN10-16	80x100 mm			•	•
SMP 1500/4/150 A0IT/50	400	3	16.5	14.2	29.5	1450	DN150 PN10-16	100x130 mm			•	•
SMP 2000/4/150 A0IT/50	400	3	20.7	16.4	36	1450	DN150 PN10-16	100x130 mm			•	•

GRINDERS	V	Phases	P1 (kW)	P2 (kW)	A	Rpm	Ø	Free passage	Suitable for BOX PRO			
									M	V	S	J
GR BluePRO 100/2/G40H A1CM/50	230	1	-	0.74	5.5	2900	G 1½"-DN32 PN6	-	•	•	•	•
GR BluePRO 100/2/G40H A1CT/50	400	3	-	0.74	2.7	2900	G 1½"-DN32 PN6	-	•	•	•	•
GR BluePRO 150/2/G40H A1CM/50	230	1	-	1.1	7.5	2900	G 1½"-DN32 PN6	-	•	•	•	•
GR BluePRO 150/2/G40H A1CT/50	400	3	-	1.1	3.2	2900	G 1½"-DN32 PN6	-	•	•	•	•
GR BluePRO 200/2/G40H A1CM/50	230	1	-	1.5	10	2900	G 1½"-DN32 PN6	-	•	•	•	•
GR BluePRO 200/2/G40H A1CT/50	400	3	-	1.5	4.3	2900	G 1½"-DN32 PN6	-	•	•	•	•
GRE 200/2/G50H A0CM/50	230	1	-	1.7	10.6	2900	G 2"-DN32 PN6	-	•	•	•	•
GRE 200/2/G50H A0CT/50	400	3	-	1.7	3.8	2900	G 2"-DN32 PN6	-	•	•	•	•
GRI 200/2/G50H A0CM/50	230	1	-	1.7	10.6	2900	G 2"-DN32 PN6	-	•	•	•	•
GRI 200/2/G50H A0CT/50	400	3	-	1.7	3.8	2900	G 2"-DN32 PN6	-	•	•	•	•
GRN 300/2/G50H A1DT/50	400	3	2.9	2.2	5.1	2900	G 2"-DN32 PN6	-			•	•
GRN 400/2/G50H A1FT/50	400	3	4.0	3	6.7	2900	G 2"-DN32 PN6	-			•	•
GRN 550/2/G50H A1FT/50	400	3	5.0	4.1	8.7	2900	G 2"-DN32 PN6	-			•	•
GRP 750/2/G50H A0HT/50	400	3	8.8	7.2	14.5	2900	G2"-DN32 PN6	-			•	•

HIGH HEAD IMPELLER	V	Phases	P1 (kW)	P2 (kW)	A	Rpm	Ø	Free passage	Suitable for BOX PRO			
									M	V	S	J
APN 250/2/G40H A1DM/50	230	1	2.7	1.8	12.5	2900	G 1½"-DN32 PN6	10 mm			•	•
APN 250/2/G40H A1DT/50	400	3	2.5	1.8	4.3	2900	G 1½"-DN32 PN6	10 mm			•	•
APN 300/2/G50H A1DT/50	400	3	3.7	2.2	5.1	2900	G 2"- DN32 PN6	10 mm			•	•
APN 400/2/G50H A1FT/50	400	3	4.0	3	6.7	2900	G 2"- DN32 PN6	10 mm			•	•
APN 550/2/G50H A1FT/50	400	3	5.0	4.1	8.7	2900	G 2"- DN32 PN6	10 mm			•	•
APP 750/2/G50H A0HT/50	400	3	8.8	7.2	14.5	2900	G 2"- DN32 PN6	10 mm			•	•
APP 1000/2/G50H A1HT/50	400	3	12.4	10	19.8	2900	G 2"- DN32 PN6	10 mm			•	•

Overall dimensions and weights*

M Type

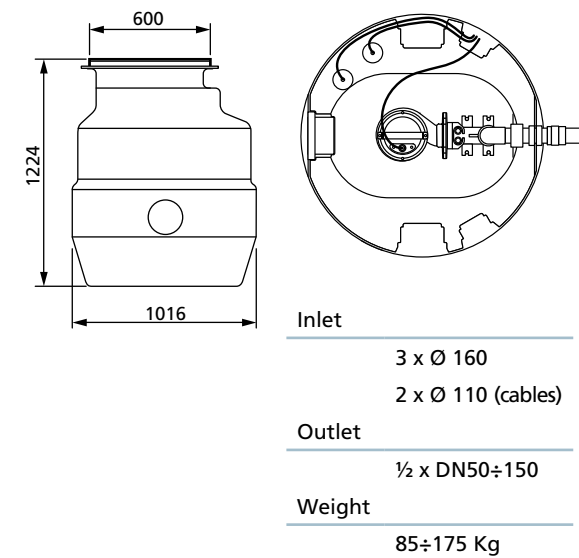

V Type

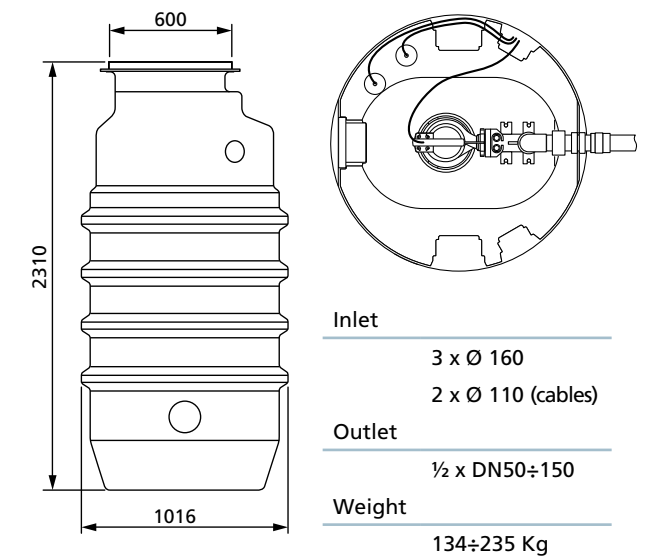

S Type

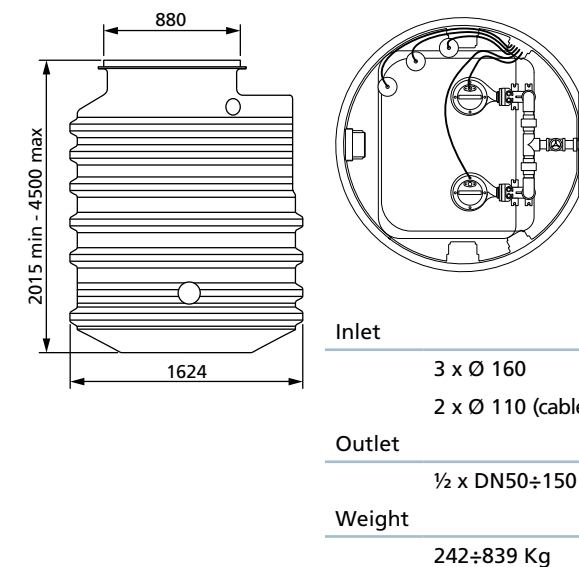

J Type

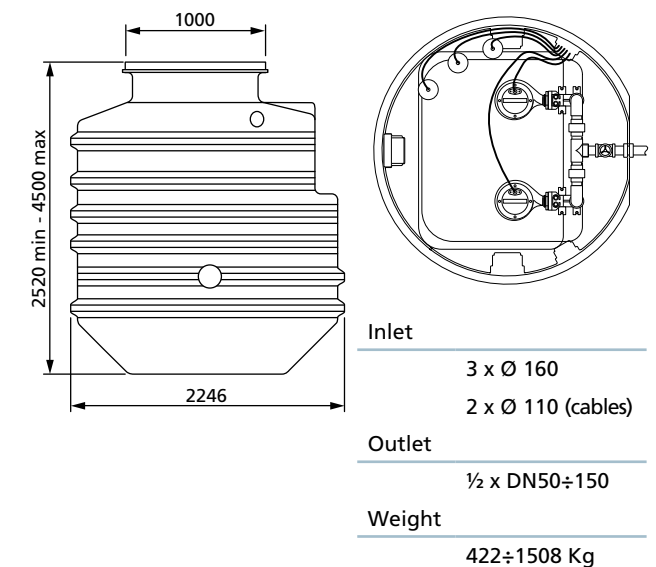

*Dimension in mm - Data without pump and accessories - All weights and dimensions are indicative only

motralec

4 rue Lavoisier . ZA Lavoisier . 95223 HERBLAY CEDEX
Tel. : 01.39.97.65.10 / Fax. : 01.39.97.68.48
Demande de prix / e-mail : service-commercial@motralec.com
www.motralec.com

The information contained herein is not binding.
Zenit reserves the right to alter the product without prior notice

EN