

PLAGES D'UTILISATION

Débits jusqu'à :	360 m ³ /h
Hauteurs mano. jusqu'à :	85 m
Plage température fluide :	- 20 ° à +140°C
Hauteurs mano. jusqu'à :	85 m
Pression service jusqu'à :	13 bar jusqu'à +140°C 16 bar jusqu'à +120°C
DN aspiration jusqu'à :	125 mm
DN refoulement jusqu'à :	125 mm
PN brides :	16 bar
MEI* de référence :	≥ 0,1

*Minimum Efficiency Index

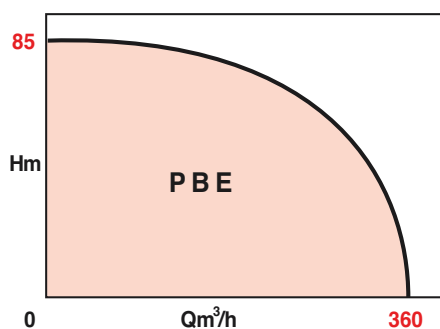

AVANTAGES

- Régulation Δp -c (capteur externe en option), PID (via un capteur approprié) et n-constante
- Large couverture de performance hydraulique (750-2900 tr/min et 380-1450 tr/min)
- Interface identique aux pompes SIE, DIE, LRE et JRE
- Un seul bouton pour la navigation et paramètres visibles sur l'écran LCD
- Interfaces 0-10 V, 2-10 V, 0-20 mA, 4-20 mA pour la comptabilité avec la majorité des organes de commande
- Communication bus grâce aux modules IF embrochables (en option)
- Verrouillage des paramètres par un switch DIP
- Signaux des relais configurables en SSM et SBM pour une intégration optimale dans la GTC
- Sonde PTC intégrée pour la protection intensités (relais thermique non nécessaire)
- Fonctionnement en pompe double avec contrôle par une pompe maître
- Revêtement cataphorèse pour une protection anticorrosion
- Rainures d'évacuation des condensants pour une utilisation en eau glacée

N.T. N° 125-9/FR. - Éd.1/05-13

PBE

POMPES MONOBLOC HORIZONTALES NORMALISÉES

Chauffage - climatisation Adduction - surpression 50 Hz

APPLICATIONS

- Circulation d'eau chaude suivant VDI2035 ou d'eau froide
- Circuits d'eau glacée ou glycolée jusqu'à 40% de glycol et température 40°C
- Circuits d'eau de refroidissement
- Irrigation, lavage
- Vidange, remplissage, surpression
- Toutes industries où il s'agit de pomper des liquides clairs, non abrasifs et chimiquement neutres.

Certifié
ACS

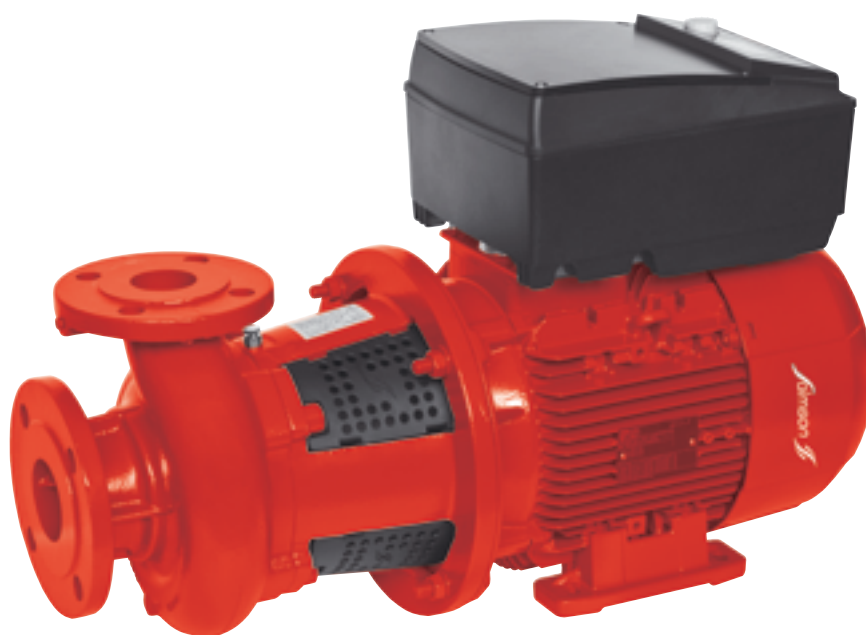

Génie climatique
Pompes à rotor sec

motralec

4 rue Lavoisier . ZA Lavoisier . 95223 HERBLAY CEDEX
Tel. : 01.39.97.65.10 / Fax. : 01.39.97.68.48
Demande de prix / e-mail : service-commercial@motralec.com
www.motralec.com

Salmson

PBE

CONCEPTION

• Partie hydraulique

- Pompe centrifuge monocellulaire monobloc horizontale normalisée.
- Raccordement à brides normalisées
- Roue fermée
- Aspiration axiale et refoulement vertical

• Etanchéité

- Garniture mécanique normalisée

• Moteur

- Accouplement rigide
- Moteur ventilé IE2

Alimentation réseau : ~400 V, 50/60 Hz

Classe d'isolation : 155 (F)

Indice de protection : IP55

Emission : EN 61800-3

Immunité : EN 61800-3

• Variateur de vitesse

- Ecran LCD
- Réglage par un bouton unique

ABAQUE PRÉSÉLECTION

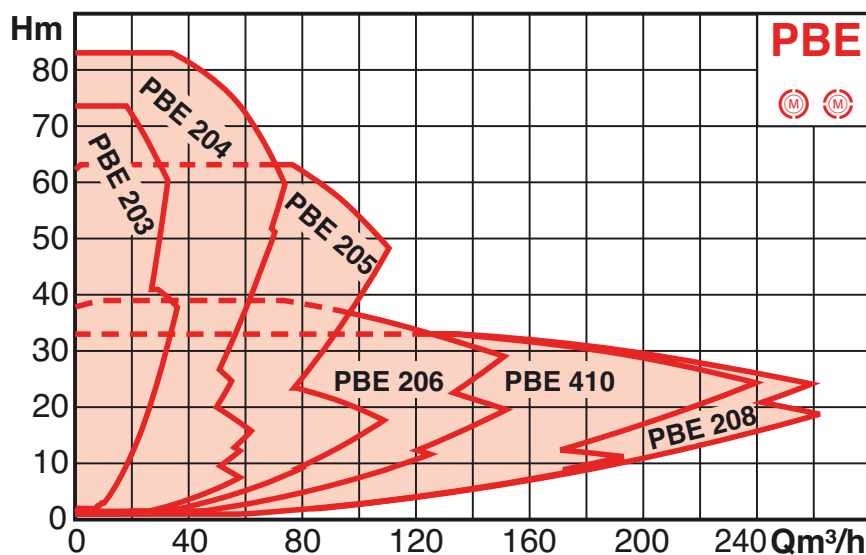

CONSTRUCTION DE BASE

Pièces principales	Matériau
Corps de pompe	Fonte EN-GJL-250 ou fonte sphéroïdale EN-GJS-400-18-LT*
Lanterne	Fonte EN-GJL-250 ou fonte sphéroïdale EN-GJS-400-18-LT*
Arbre moteur	Inox 1.4122
Roue	Fonte EN-GJL-200 ou bronze G-CuSn 10*
Garniture mécanique	AQEGG

* Options, nous consulter

IDENTIFICATION

PBE 203 - 14 / 2,2 - R1

Gammes de produits _____

Nombre de pôles _____

Diamètre nominal de la bride _____
 03 : 32mm
 04 : 45mm
 05 : 50 mm
 06 : 65 mm
 08 : 80 mm
 10 : 100 mm

Diamètre nominal de la roue en mm _____

Puissance P2 en kW _____

sans capteur de pression _____

VARIATION ÉLECTRONIQUE DE VITESSE

Description

1,5 - 7,5 kW

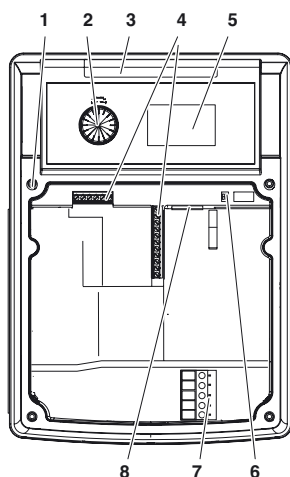

11 - 22 kW

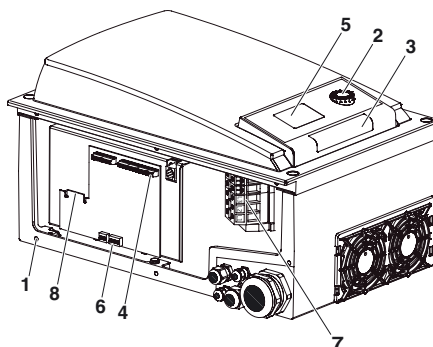

- 1 Fixation du couvercle
- 2 Bouton de contrôle
- 3 Fenêtre communication infra-rouge
- 4 Connecteurs de commande
- 5 Affichage
- 6 Interrupteurs
- 7 Bornier de puissance
- 8 Interface pour les modules IF

Fonctionnalités

Modes automatiques

- Δp -c pour pression différentielle constante (avec un DDG externe)
- Contrôle PID
- Mode réglage manuel (n = constant)

Sécurité

- Protection moteur intégrale avec déclencheur électronique intégré
- Verrouillage d'accès

Réglages manuelles

- Réglage de la consigne de pression différentielle
- Réglage de la vitesse de rotation (mode réglage)
- Réglage du mode de fonctionnement
- Réglage de la pompe sur MARCHE/ARRET
- Configuration de tous les paramètres de fonctionnement
- Acquiescement des défauts

Pilotage pompes doubles (pompe double ou 2 pompes simples)

- Mode de fonctionnement principal/de réserve (permutation automatique en cas de défaut)
- Mode de fonctionnement principal/de réserve permutation des pompes au bout de 24 heures
- Marche parallèle
- Marche parallèle (avec optimisation du rendement en fonction des besoins)

Fonctions de commandes externes

- Entrée de commande « Priorité Off ».
- Entrée de commande « Permutation des pompes externe » (uniquement active en mode double pompe).
- Entrée analogique 0-10 V, 0-20 mA pour mode réglage (DDC) et réglage à distance de la valeur de consigne.

- Entrée analogique 2-10 V, 4-20 mA pour mode réglage (DDC) et réglage à distance de la valeur de consigne.
- Entrée analogique 0-10 V pour le signal valeur réelle du capteur de pression.
- Entrée analogique 2-10 V, 0-20 mA, 4-20 mA pour signal valeur réelle du capteur de pression.

Signalisation et affichage

- Report de défauts centralisé SSM.
- Report de marche centralisé SBM.

Echange de données

Interface infrarouge pour l'échange de données sans fil avec le Pump Control.
Emplacement pour modules IF Salmson (Modbus, BACnet, CAN, PLR, LON) pour la connexion à la gestion technique centralisée
Interface pour le pilotage pompes doubles.

POSITIONS DE MONTAGE

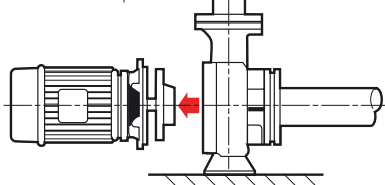
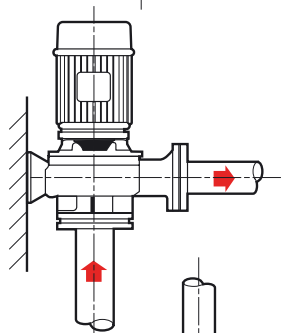
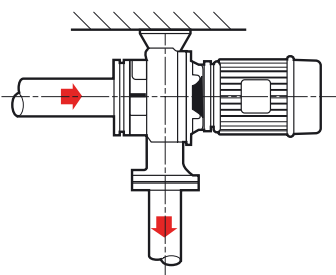
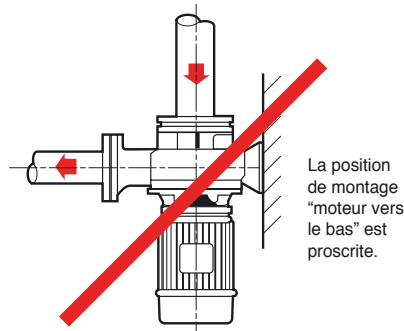
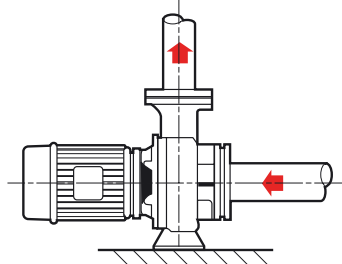

ACCESSOIRES RECOMMANDES

• **Kit capteur de pression différentielle** pour les versions R1, mesure de 0 à 10 bar, sortie 0-10 V (à installer à l'aspiration et au refoulement de la pompe sur une longueur droite).

Kit composé de :

- Capteur de pression différentiel avec câble de 2 m,
- Capillaire cuivre de Ø 3 mm et de longueur 2 m,
- Accessoires de montage

Pompe		Kit capteur de pression	
Référence	Désignation	Référence	Désignation
2126163	PBE203-14/2.2-R1	2137283	DDG40-9 PBE
2126164	PBE203-15/3-R1	2137283	DDG40-9 PBE
2126165	PBE203-16/4-R1	2137283	DDG40-9 PBE
2126166	PBE203-17/5.5-R1	2137286	DDG60-5 PBE
2126167	PBE203-21/7.5-R1	2137288	DDG100-2 PBE
2126168	PBE203-22/11-R1	2137289	DDG100-3 PBE
2126169	PBE204-11/1.5-R1	2137280	DDG20-10 PBE
2126170	PBE204-12/2.2-R1	2137280	DDG20-10 PBE
2126171	PBE204-13/3-R1	2137283	DDG40-9 PBE
2126172	PBE204-14/4-R1	2137283	DDG40-9 PBE
2126173	PBE204-16/5.5-R1	2137284	DDG40-10 PBE
2126174	PBE204-17/7.5-R1	2137286	DDG60-5 PBE
2126175	PBE204-18/7.5-R1	2137286	DDG60-5 PBE
2126176	PBE204-21/11-R1	2137287	DDG60-6 PBE
2126177	PBE204-22/15-R1	2137289	DDG100-3 PBE
2113494	PBE204-23/18.5-R1	2137289	DDG100-3 PBE
2126178	PBE204-24/22-R1	2137289	DDG100-3 PBE
2126179	PBE205-11/3-R1	2137280	DDG20-10 PBE
2126180	PBE205-12/4-R1	2137280	DDG20-10 PBE
2126181	PBE205-13/5.5-R1	2137284	DDG40-10 PBE
2126182	PBE205-14/7.5-R1	2137284	DDG40-10 PBE
2126183	PBE205-15/7.5-R1	2137284	DDG40-10 PBE
2126184	PBE205-17/11-R1	2137287	DDG60-6 PBE
2126185	PBE205-20/15-R1	2137287	DDG60-6 PBE
2126186	PBE205-21/18.5-R1	2137287	DDG60-6 PBE
2126187	PBE205-22/22-R1	2137289	DDG100-3 PBE
2126188	PBE405-27/5.5-R1	2137284	DDG40-10 PBE
2126189	PBE206-12/4-R1	2137280	DDG20-10 PBE
2126190	PBE206-13/5.5-R1	2137281	DDG20-11 PBE
2126191	PBE206-14/7.5-R1	2137284	DDG40-10 PBE
2126192	PBE206-16/11-R1	2137285	DDG40-11 PBE
2126193	PBE206-17/15-R1	2137285	DDG40-11 PBE
2126194	PBE206-19/18.5-R1	2137287	DDG60-6 PBE
2126195	PBE206-21/22-R1	2137287	DDG60-6 PBE
2126196	PBE406-24/5.5-R1	2137284	DDG40-10 PBE
2113533	PBE406-26.5/7.5-R1	2137284	DDG40-10 PBE
2126197	PBE208-14.5/11-R1	2137285	DDG40-11 PBE
2126198	PBE208-15/15-R1	2137285	DDG40-11 PBE
2126199	PBE208-16/18.5-R1	2137285	DDG40-11 PBE
2126200	PBE208-16.5/22-R1	2137285	DDG40-11 PBE
2126201	PBE408-22/5.5-R1	2137281	DDG20-11 PBE
2126202	PBE408-25/7.5-R1	2137284	DDG40-10 PBE
2126203	PBE408-27/11-R1	2137285	DDG40-11 PBE
2126204	PBE410-20/5.5-R1	2137281	DDG20-11 PBE
2126205	PBE410-22/7.5-R1	2137281	DDG20-11 PBE
2126206	PBE410-25/11-R1	-	-
2126207	PBE410-27/15-R1	2137285	DDG40-11 PBE
2126208	PBE410-30.5/18.5-R1	2137285	DDG40-11 PBE
2126209	PBE410-31.5/22-R1	2137285	DDG40-11 PBE
2126210	PBE412-18.5/5.5-R1	2137281	DDG20-11 PBE
2126211	PBE412-21/7.5-R1	2137281	DDG20-11 PBE
2126212	PBE412-22.5/11-R1	2137282	DDG20-12 PBE
2126213	PBE412-25/15-R1	2137282	DDG20-12 PBE
2126214	PBE412-26/18.5-R1	2137285	DDG40-11 PBE
2126215	PBE412-27/22-R1	2137285	DDG40-11 PBE

Nota : il ne doit pas être raccordé sur les bossages de la pompe tels que les LRE/JRE.

CARACTERISTIQUES – MOTEUR ≤ 4KW

Référence article	Référence SAP	Moteur	DN1 aspiration (mm)	DN2 refoulement (mm)	Masse nette (kg)	PN bride	Puissance nominale moteur (P2)	Nombre de pôles	Plage de vitesse (tr/min)	Intensité nominale (A)	Tension (V)	Fréquence (Hz)	Presse étoupe
2126163	PBE203-14/2.2-R1	V1	50	32	47,5	PN16	2,2	2	750 2900	7,3	3~400 V ±10%	50/60 Hz	2xM12 1xM16 1xM20 1xM25
2126164	PBE203-15/3-R1	V1	50	32	60	PN16	3	2	750 2900	9	3~400 V ±10%	50/60 Hz	2xM12 1xM16 1xM20
2126165	PBE203-16/4-R1	V1	50	32	69	PN16	4	2	750 2900	11,7	3~400 V ±10%	50/60 Hz	2xM12 1xM16 1xM20 1xM25
2126169	PBE204-11/1.5-R1	V1	65	40	47,5	PN16	1,5	2	750 2900	5,6	3~400 V ±10%	50/60 Hz	2xM12 1xM16 1xM20 1xM25
2126170	PBE204-12/2.2-R1	V1	65	40	46	PN16	2,2	2	750 2900	7,2	3~400 V ±10%	50/60 Hz	2xM12 1xM16 1xM20 1xM25
2126171	PBE204-13/3-R1	V1	65	40	55	PN16	3	2	750 2900	8,9	3~400 V ±10%	50/60 Hz	2xM12 1xM16 1xM20 1xM25
2126172	PBE204-14/4-R1	V1	65	40	66	PN16	4	2	750 2900	11,3	3~400 V ±10%	50/60 Hz	2xM12 1xM16 1xM20 1xM25
2126179	PBE205-11/3-R1	V1	65	50	60	PN16	3	2	750 2900	8,7	3~400 V ±10%	50/60 Hz	2xM12 1xM16 1xM20 1xM25
2126180	PBE205-12/4-R1	V1	65	50	69	PN16	4	2	750 2900	11,5	3~400 V ±10%	50/60 Hz	2xM12 1xM16 1xM20 1xM25
2126189	PBE206-12/4-R1	V1	80	65	74	PN16	4	2	750 2900	10,7	3~400 V ±10%	50/60 Hz	2xM12 1xM16 1xM20 1xM25

CARACTERISTIQUES – MOTEUR ≤ 5,5KW

Référence article	Référence SAP	Moteur	DN1 aspiration (mm)	DN2 refoulement (mm)	Masse nette (kg)	PN bride	Puissance nominale moteur (P2)	Nombre de pôles	Plage de vitesse (tr/min)	Intensité nominale (A)	Tension (V)	Fréquence (Hz)	Presse étoupe
2126166	PBE203-17/5.5-R1	B35	50	32	83	PN16	5,5	2	750 2900	10,5	3~400 V ±10%	50/60 Hz	1xM12 2xM16 1xM20 1xM25
2126167	PBE203-21/7.5-R1	B35	50	32	99	PN16	7,5	2	750 2900	13,5	3~400 V ±10%	50/60 Hz	1xM12 2xM16 1xM20 1xM25
2126168	PBE203-22/11-R1	B35	50	32	132	PN16	11	2	750 2900	18,8	3~400 V ±10%	50/60 Hz	1xM12 2xM16 1xM20 1xM25
2126173	PBE204-16/5.5-R1	B35	65	40	86	PN16	5,5	2	750 2900	11	3~400 V ±10%	50/60 Hz	1xM12 2xM16 1xM20 1xM25
2126174	PBE204-17/7.5-R1	B35	65	40	93	PN16	7,5	2	750 2900	14	3~400 V ±10%	50/60 Hz	1xM12 2xM16 1xM20 1xM25
2126175	PBE204-18/7.5-R1	B35	65	40	107	PN16	7,5	2	750 2900	14,1	3~400 V ±10%	50/60 Hz	1xM12 2xM16 1xM20 1xM25
2126176	PBE204-21/11-R1	B35	65	40	135	PN16	11	2	750 2900	19,2	3~400 V ±10%	50/60 Hz	1xM12 2xM16 1xM20 1xM25
2126177	PBE204-22/15-R1	B35	65	40	143	PN16	15	2	750 2900	25	3~400 V ±10%	50/60 Hz	1xM12 2xM16 1xM20 1xM25
2113494	PBE204-23/18.5-R1	B35	65	40	0	PN16	18,5	2	750 2900	34,2	3~400 V ±10%	50/60 Hz	1xM12 2xM16 1xM20 1xM25
2126178	PBE204-24/22-R1	B35	65	40	199	PN16	22	2	750 2900	39,5	3~400 V ±10%	50/60 Hz	1xM12 2xM16 1xM20 1xM25
2126181	PBE205-13/5.5-R1	B35	65	50	81	PN16	5,5	2	750 2900	10,7	3~400 V ±10%	50/60 Hz	1xM12 2xM16 1xM20 1xM25
2126182	PBE205-14/7.5-R1	B35	65	50	88	PN16	7,5	2	750 2900	13,8	3~400 V ±10%	50/60 Hz	1xM12 2xM16 1xM20 1xM25
2126183	PBE205-15/7.5-R1	B35	65	50	96	PN16	7,5	2	750 2900	14,3	3~400 V ±10%	50/60 Hz	1xM12 2xM16 1xM20 1xM25
2126184	PBE205-17/11-R1	B35	65	50	120	PN16	11	2	750 2900	20,9	3~400 V ±10%	50/60 Hz	1xM12 2xM16 1xM20 1xM25
2126185	PBE205-20/15-R1	B35	65	50	144	PN16	15	2	750 2900	26,9	3~400 V ±10%	50/60 Hz	1xM12 2xM16 1xM20 1xM25

CARACTERISTIQUES – MOTEUR ≤ 5,5KW

2126186	PBE205-21/18.5-R1	B35	65	50	161	PN16	18,5	2	750 2900	32,3	3~400 V ±10%	50/60 Hz	1xM12 2xM16 1xM20 1xM25
2126187	PBE205-22/22-R1	B35	65	50	191	PN16	22	2	750 2900	39,2	3~400 V ±10%	50/60 Hz	1xM12 2xM16 1xM20 1xM25
2126188	PBE405-27/5.5-R1	B35	65	50	111	PN16	5,5	4	750 2900	10,7	3~400 V ±10%	50/60 Hz	1xM12 2xM16 1xM20 1xM25
2126190	PBE206-13/5.5-R1	B35	80	65	74	PN16	5,5	2	750 2900	11	3~400 V ±10%	50/60 Hz	1xM12 2xM16 1xM20 1xM25
2126191	PBE206-14/7.5-R1	B35	80	65	85	PN16	7,5	2	750 2900	14,1	3~400 V ±10%	50/60 Hz	1xM12 2xM16 1xM20 1xM25
2126192	PBE206-16/11-R1	B35	80	65	139	PN16	11	2	750 2900	20,1	3~400 V ±10%	50/60 Hz	1xM12 2xM16 1xM20 1xM25
2126193	PBE206-17/15-R1	B35	80	65	133	PN16	15	2	750 2900	26,7	3~400 V ±10%	50/60 Hz	1xM12 2xM16 1xM20 1xM25
2126197	PBE208-14.5/11-R1	B35	100	80	136	PN16	11	2	750 2900	20,6	3~400 V ±10%	50/60 Hz	1xM12 2xM16 1xM20 1xM25
2126198	PBE208-15/15-R1	B35	100	80	143	PN16	15	2	750 2900	27,8	3~400 V ±10%	50/60 Hz	1xM12 2xM16 1xM20 1xM25
2126199	PBE208-16/18.5-R1	B35	100	80	160	PN16	18,5	2	750 2900	32,6	3~400 V ±10%	50/60 Hz	1xM12 2xM16 1xM20 1xM25
2126200	PBE208-16.5/22-R1	B35	100	80	190	PN16	22	2	750 2900	38,8	3~400 V ±10%	50/60 Hz	1xM12 2xM16 1xM20 1xM25
2126201	PBE408-22/5.5-R1	B35	100	80	118	PN16	5,5	4	750 2900	10,9	3~400 V ±10%	50/60 Hz	1xM12 2xM16 1xM20 1xM25
2126204	PBE410-20/5.5-R1	B35	125	100	125	PN16	5,5	4	750 2900	10,5	3~400 V ±10%	50/60 Hz	1xM12 2xM16 1xM20 1xM25
2126205	PBE410-22/7.5-R1	B35	125	100	138	PN16	7,5	4	750 2900	13,6	3~400 V ±10%	50/60 Hz	1xM12 2xM16 1xM20 1xM25
2126208	PBE410-30.5/18.5-R1	B35	125	100	250	PN16	18,5	4	750 2900	32	3~400 V ±10%	50/60 Hz	1xM12 2xM16 1xM20 1xM25
2126209	PBE410-31.5/22-R1	B35	125	100	267	PN16	22	4	750 2900	37,7	3~400 V ±10%	50/60 Hz	1xM12 2xM16 1xM20 1xM25

PERFORMANCES HYDRAULIQUES

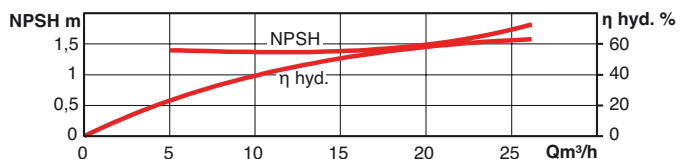
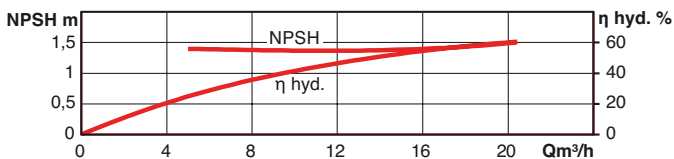
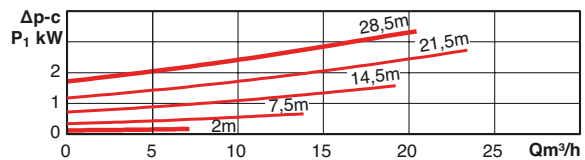
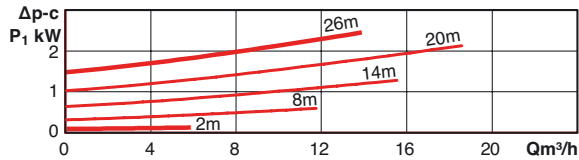
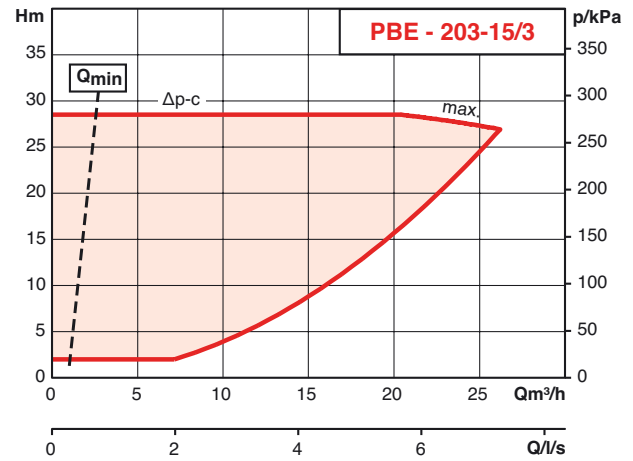
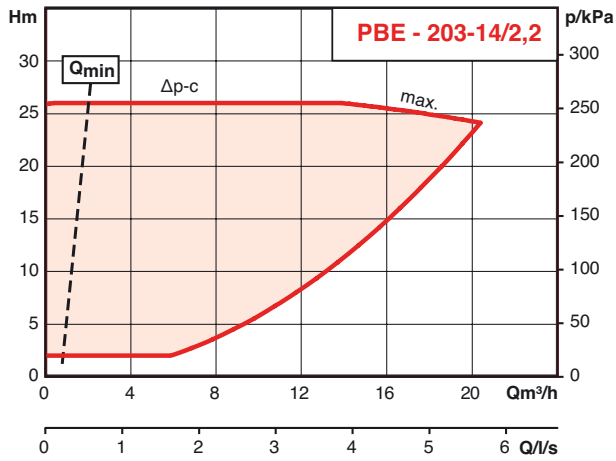
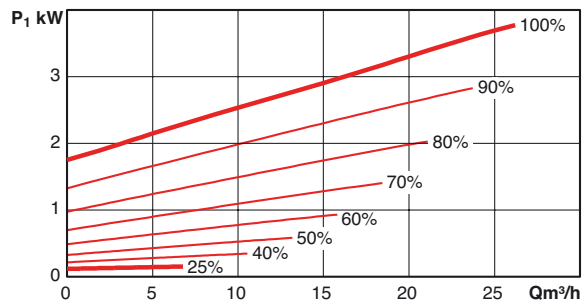
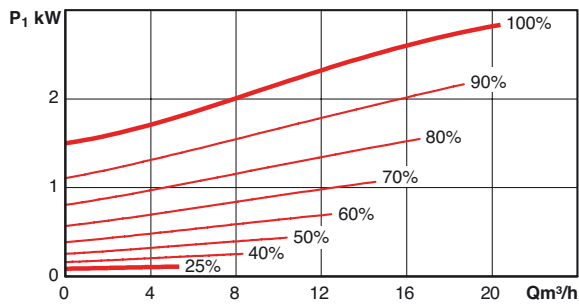
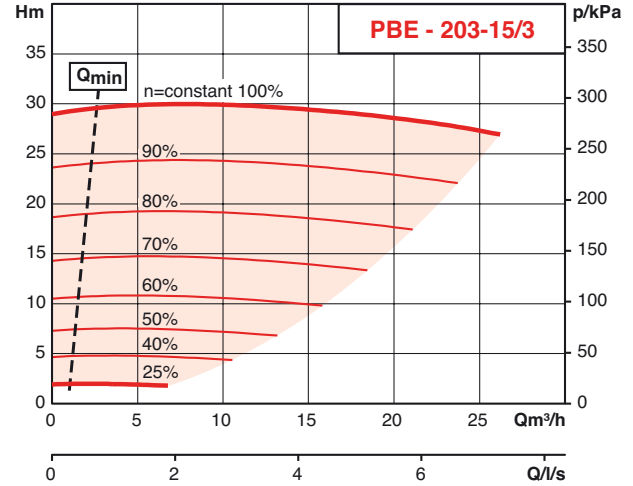
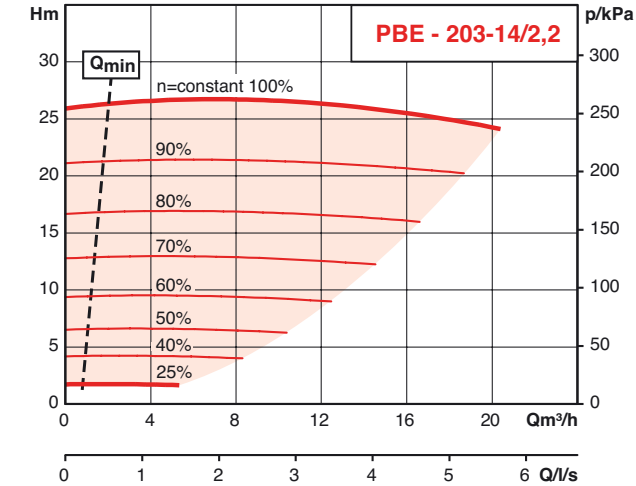

PERFORMANCES HYDRAULIQUES

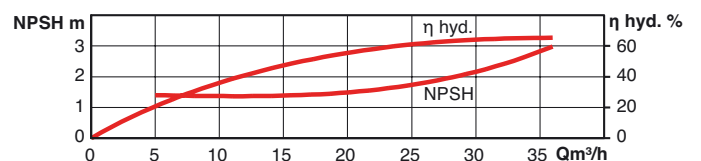
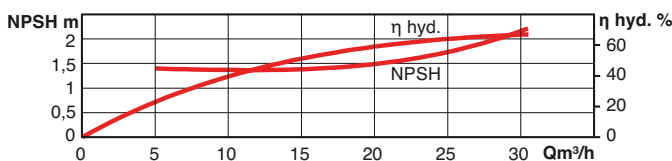
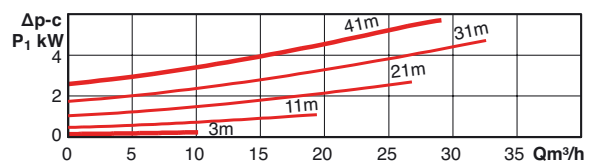
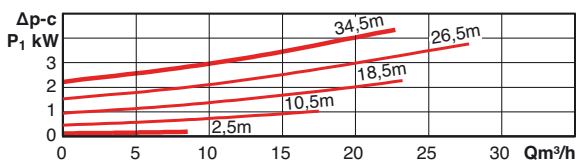
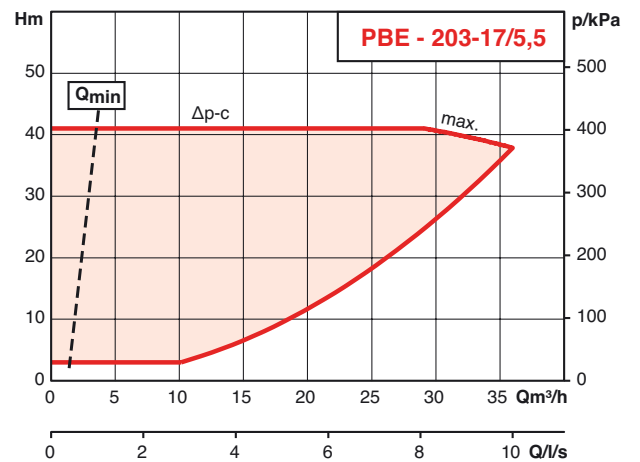
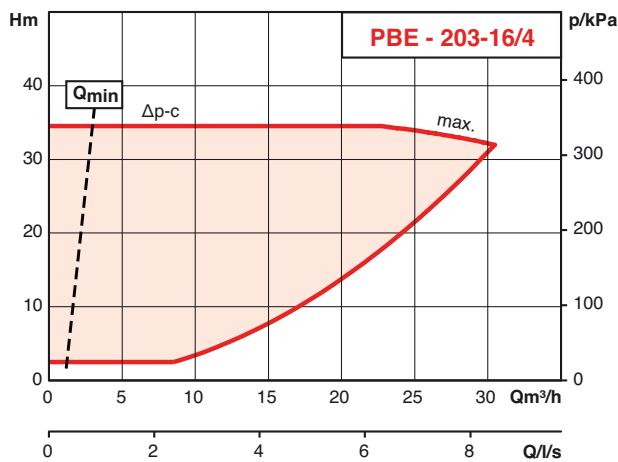
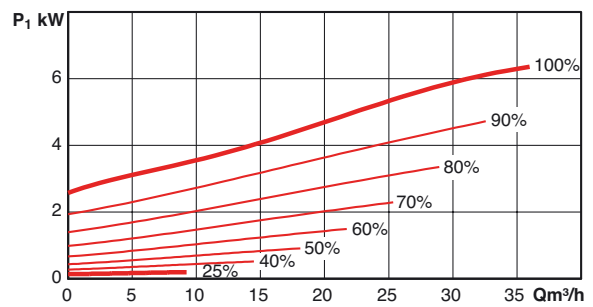
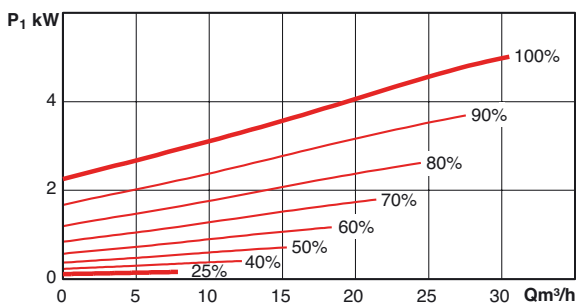
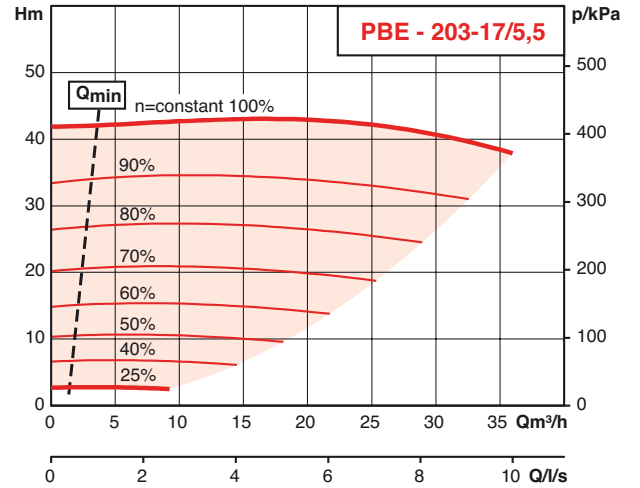
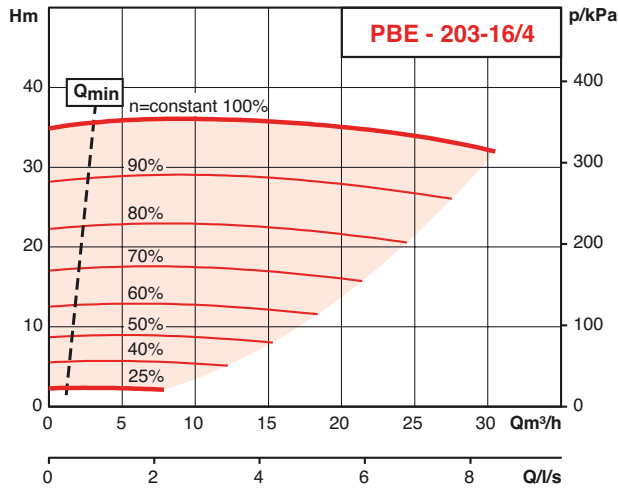

Génie climatique
Pompes à rotor sec

PERFORMANCES HYDRAULIQUES

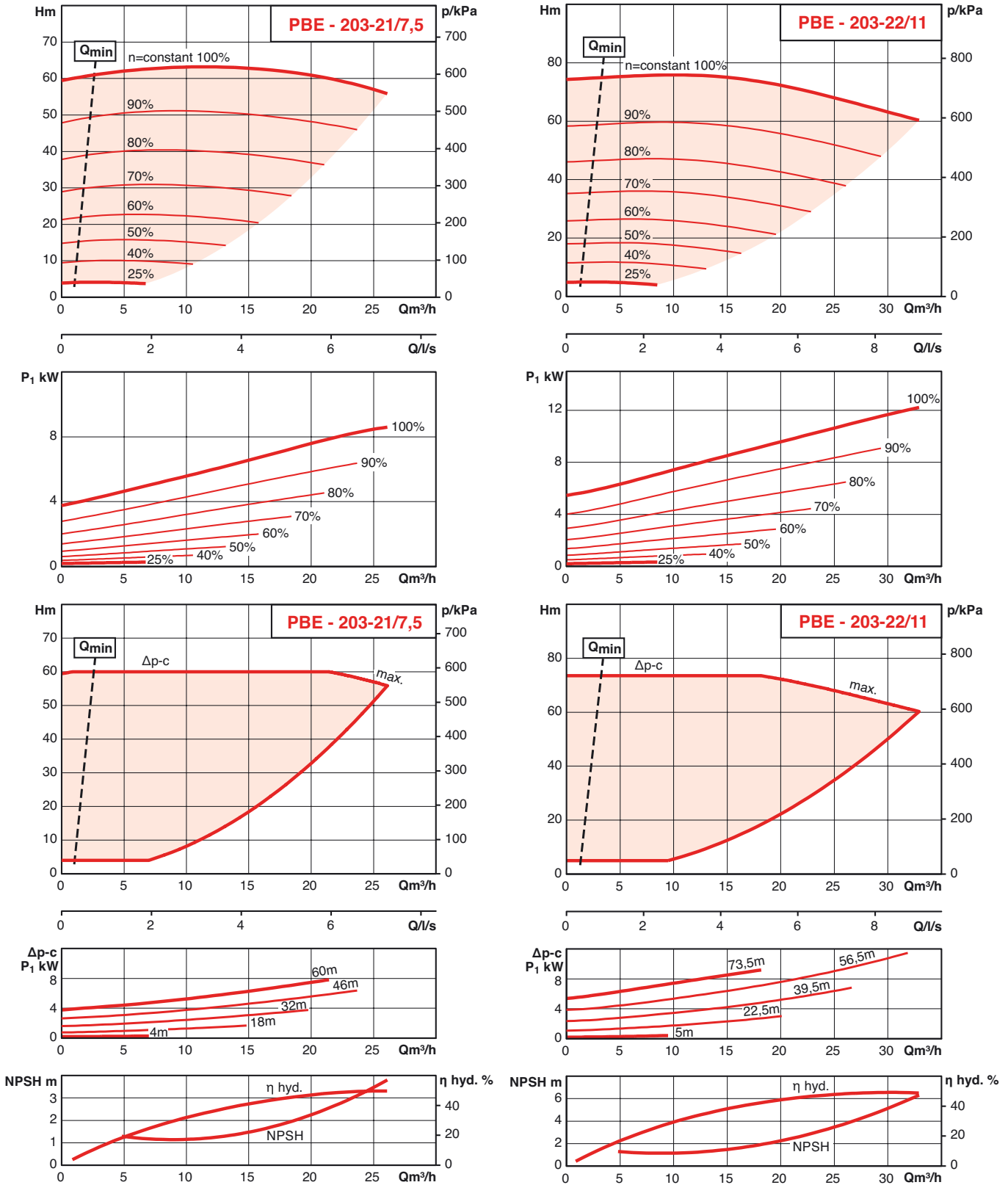

PERFORMANCES HYDRAULIQUES

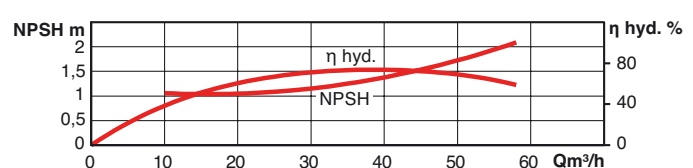
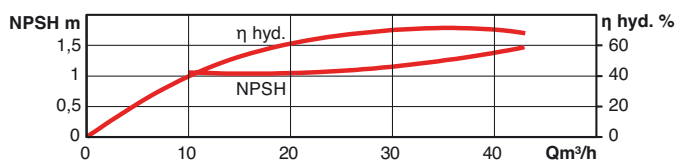
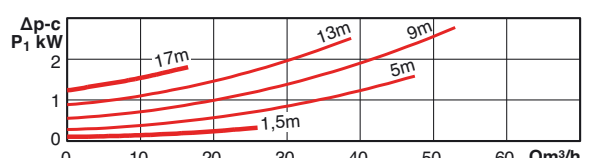
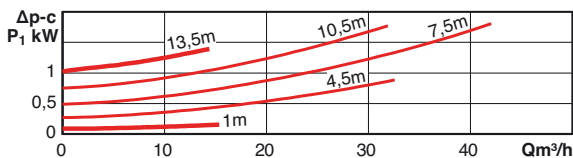
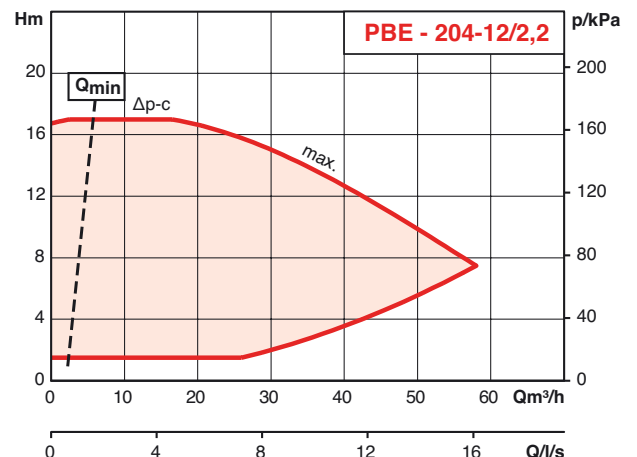
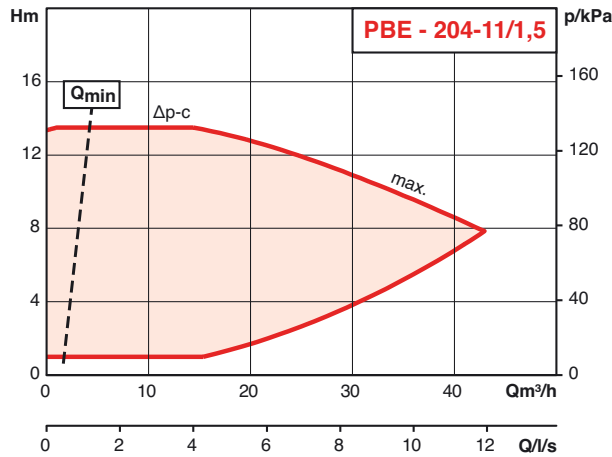
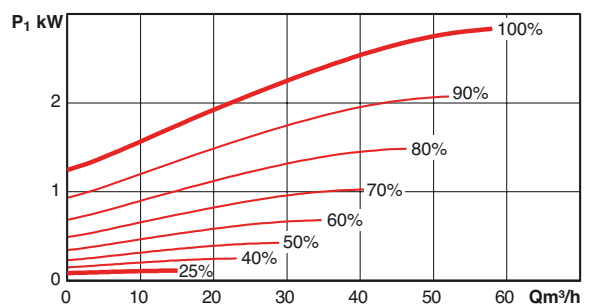
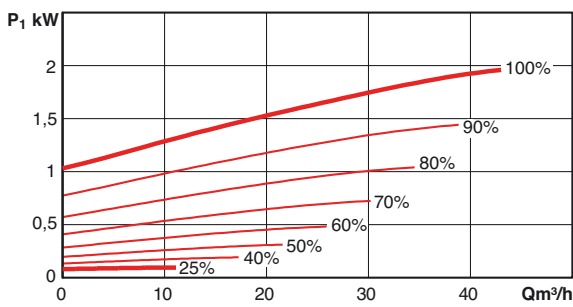
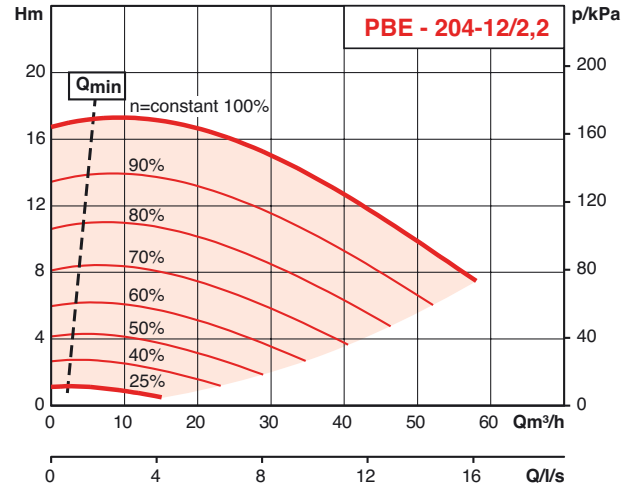
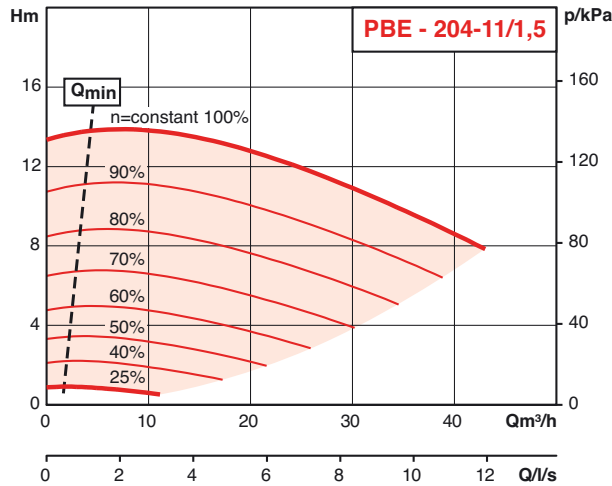

Génie climatique
Pompes à rotor sec

PERFORMANCES HYDRAULIQUES

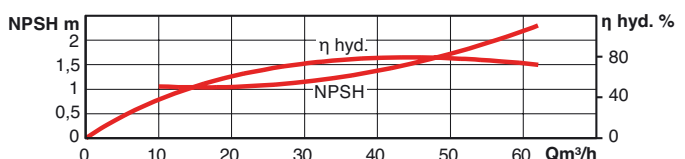
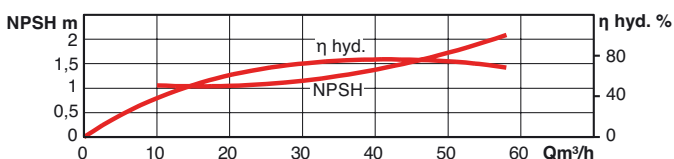
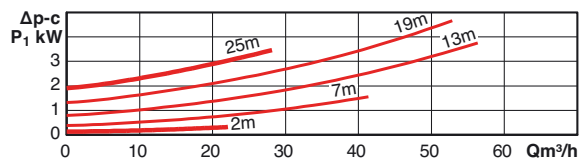
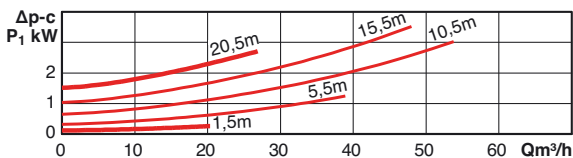
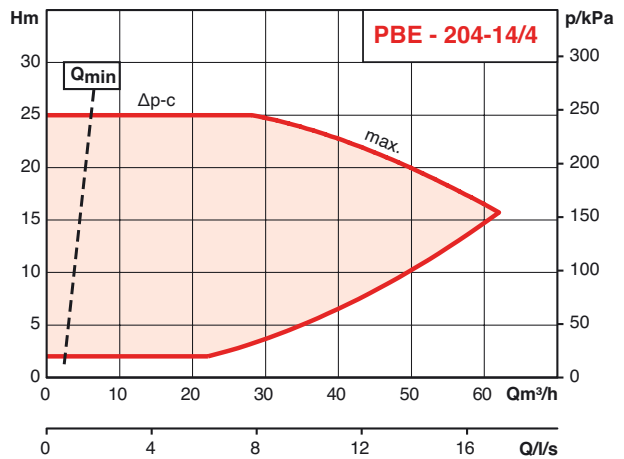
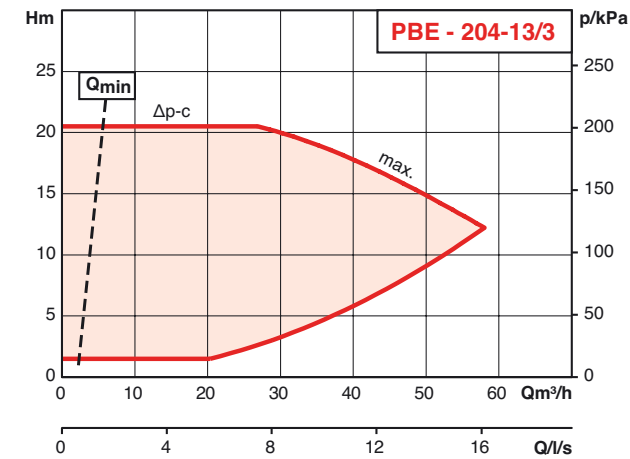
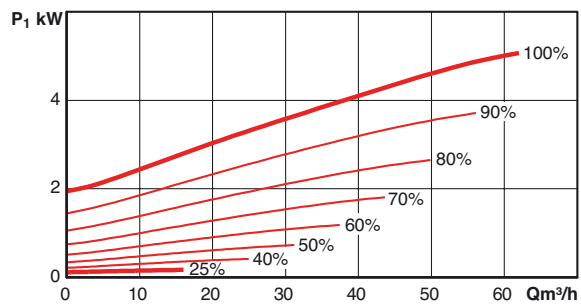
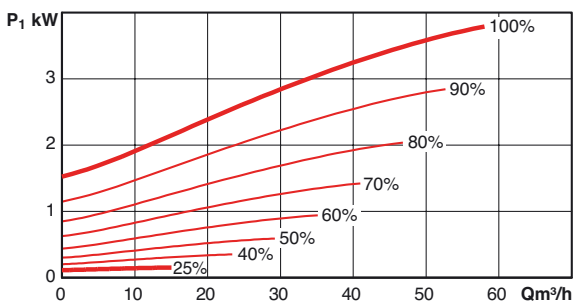
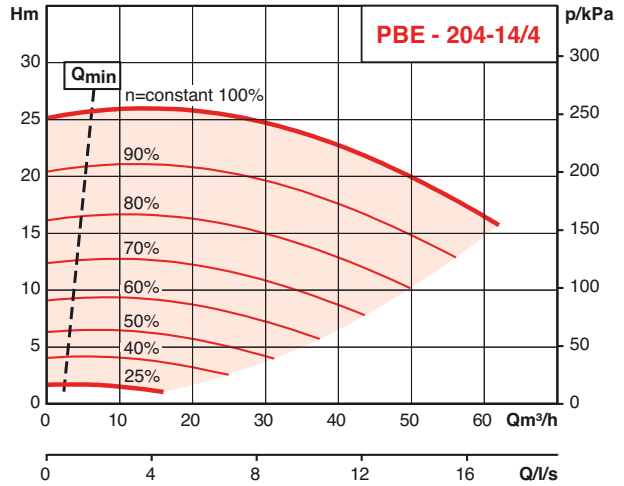
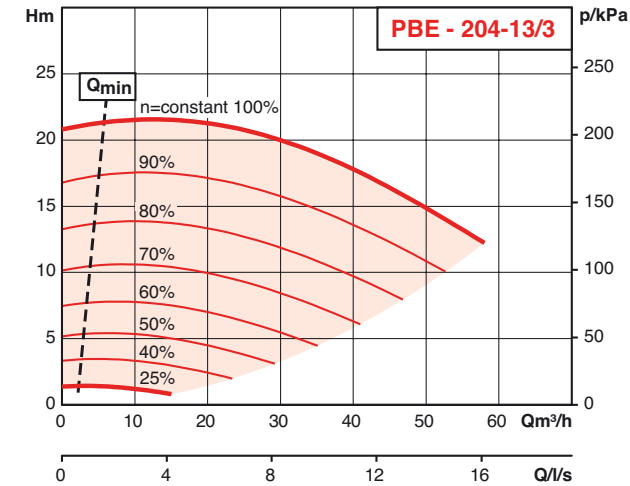

PERFORMANCES HYDRAULIQUES

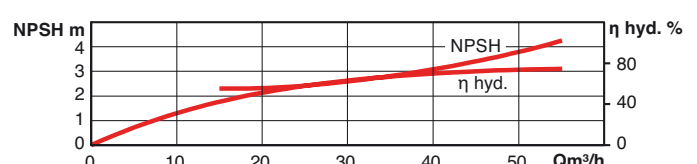
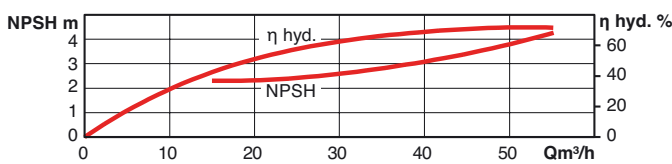
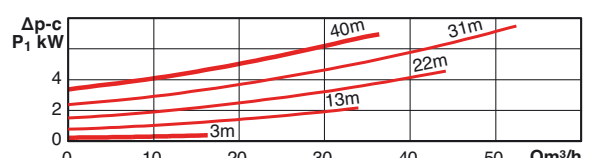
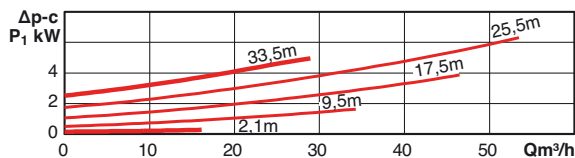
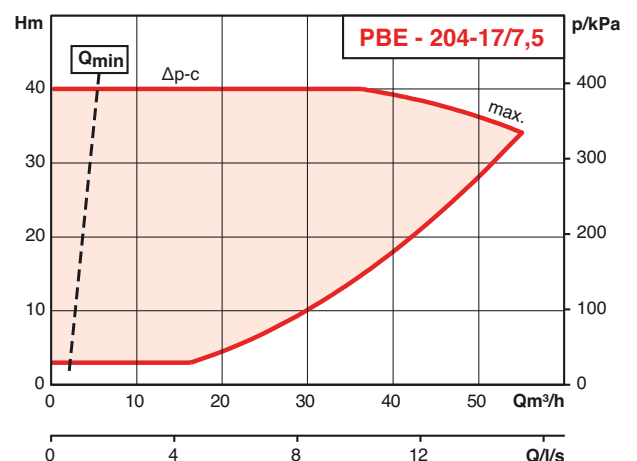
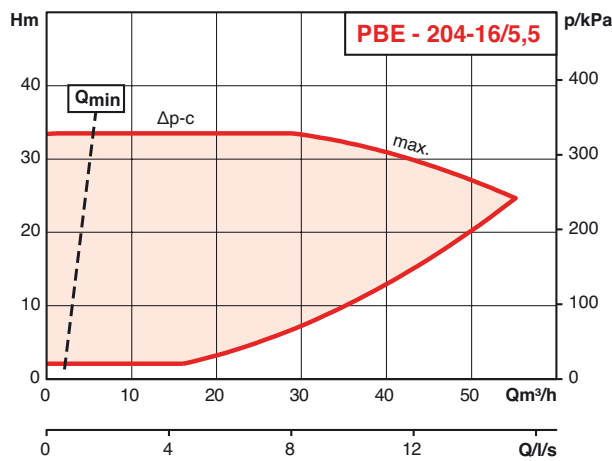
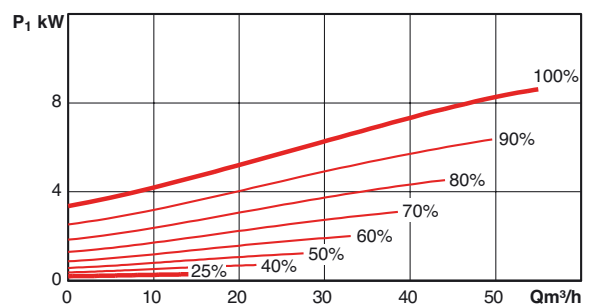
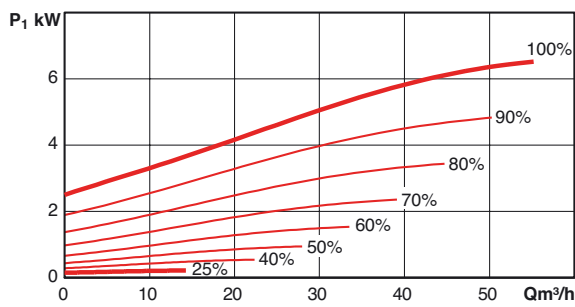
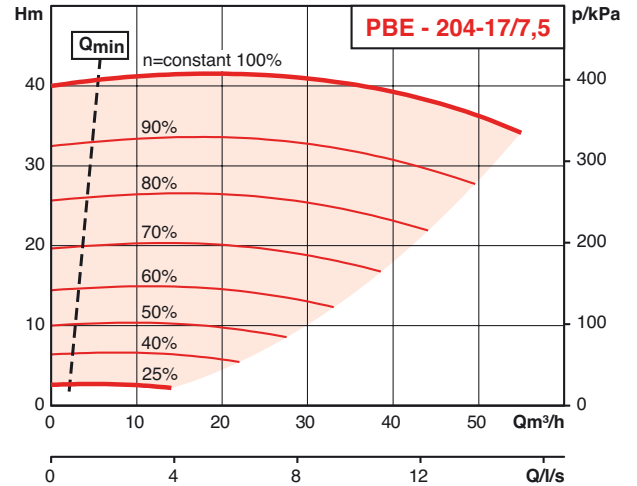
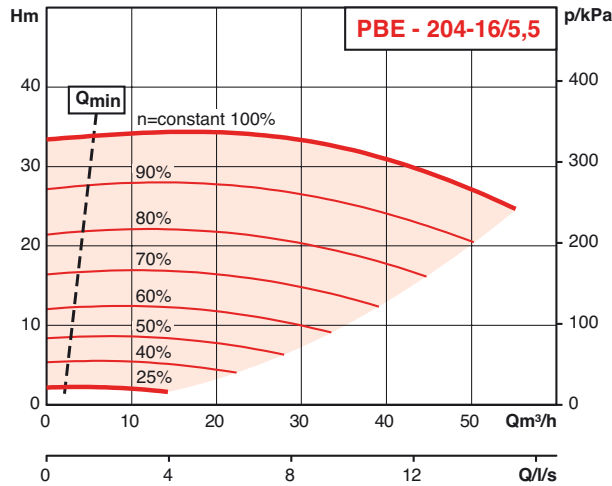

Génie climatique
Pompes à rotor sec

PERFORMANCES HYDRAULIQUES

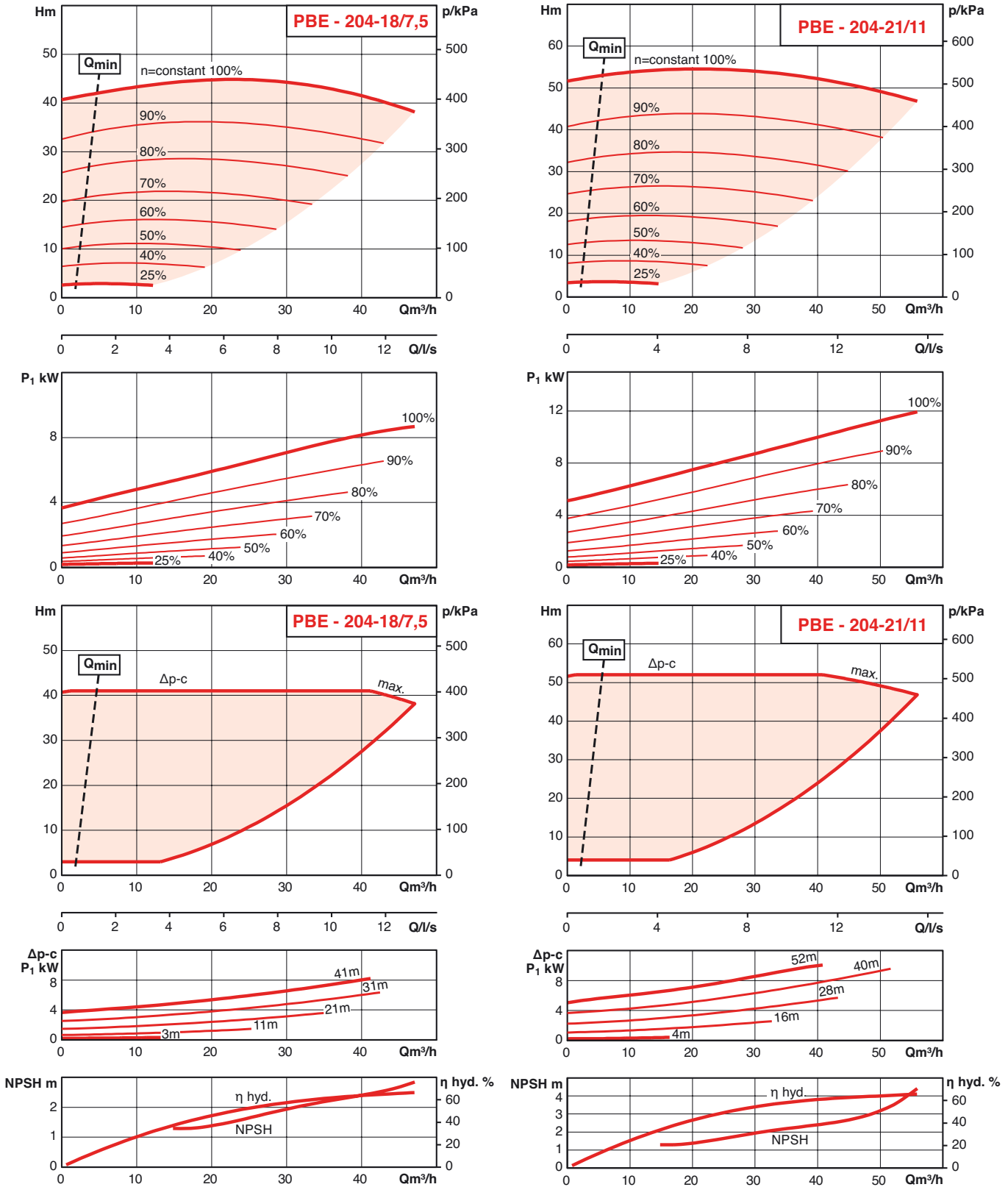

PERFORMANCES HYDRAULIQUES

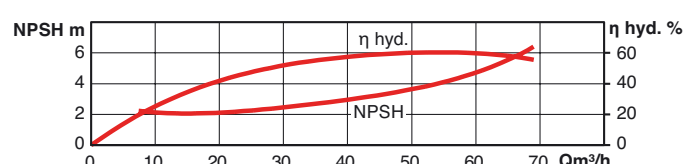
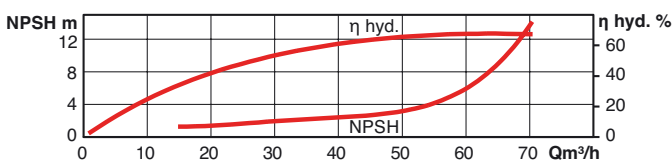
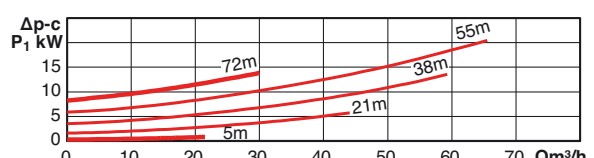
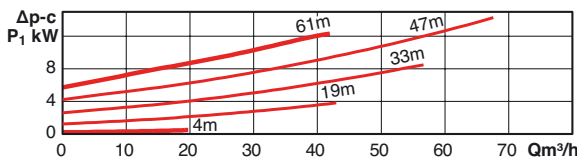
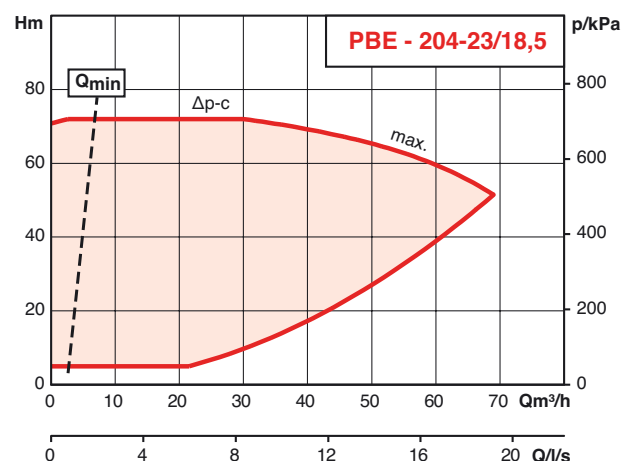
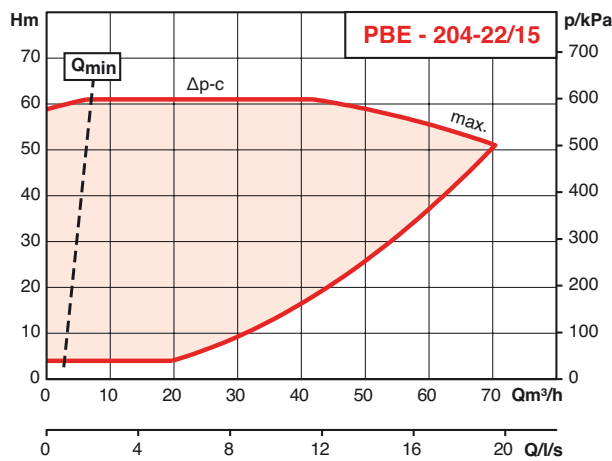
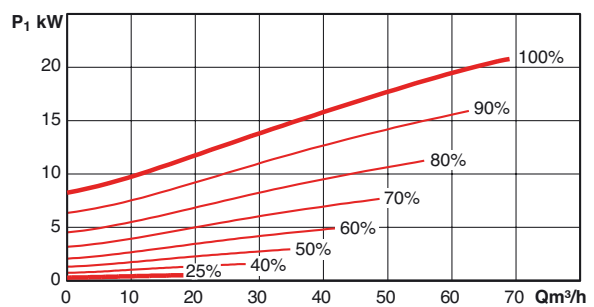
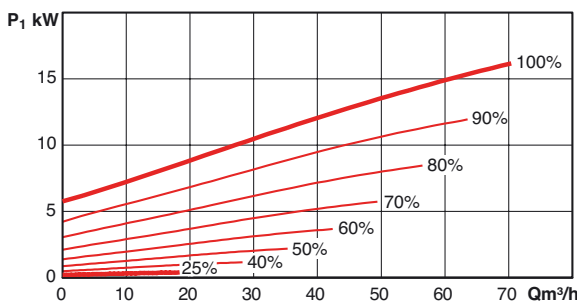
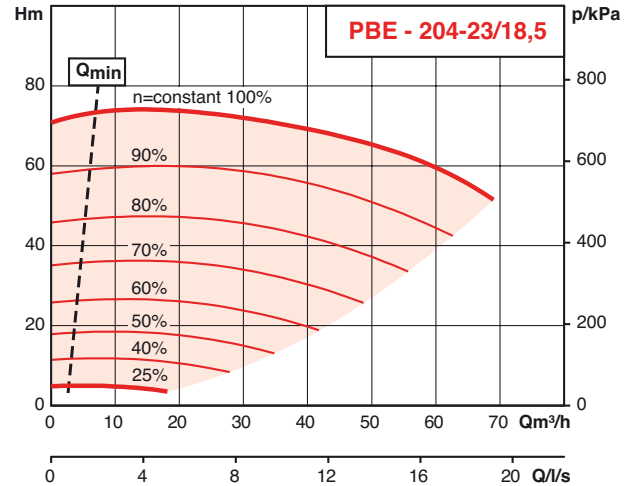
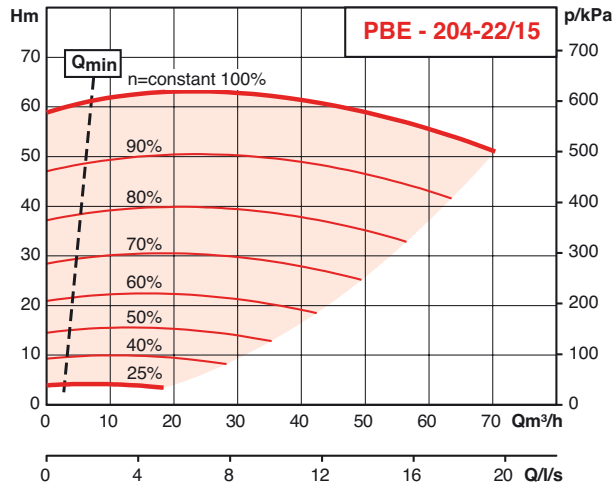

Génie climatique
Pompes à rotor sec

PERFORMANCES HYDRAULIQUES

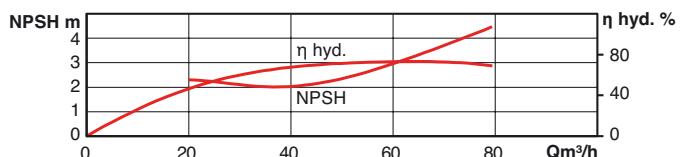
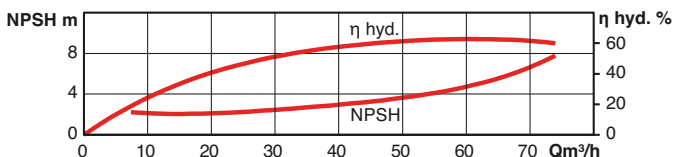
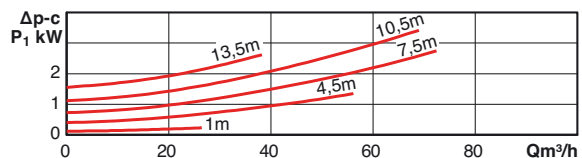
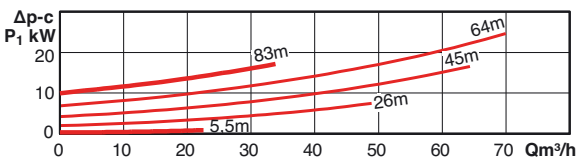
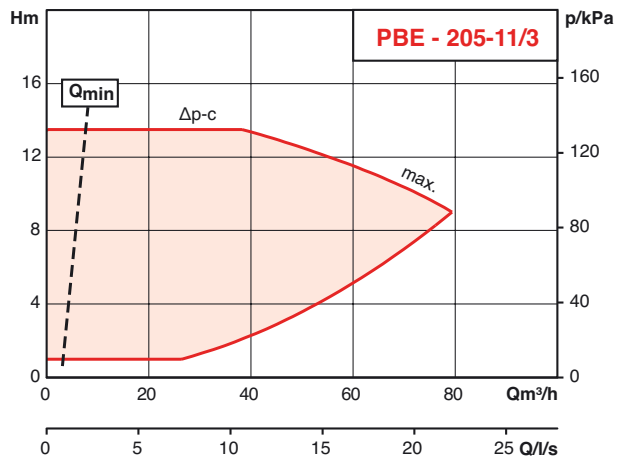
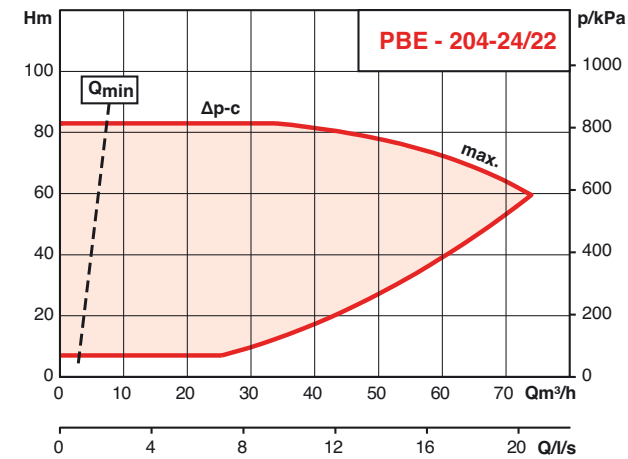
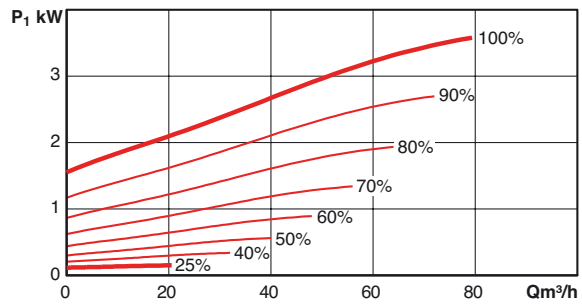
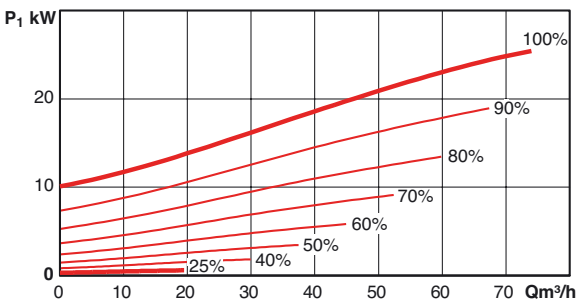
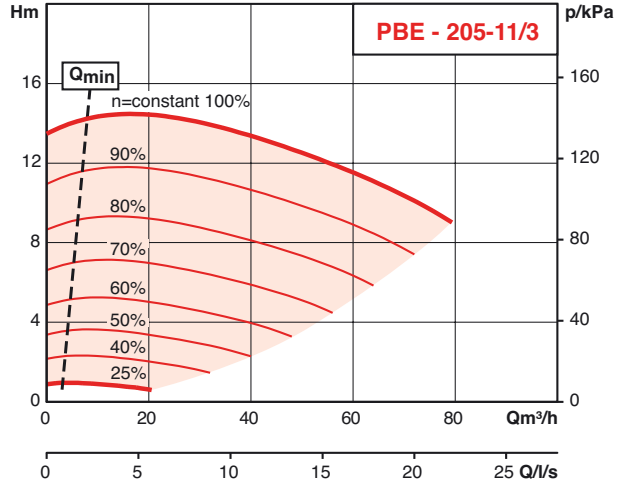
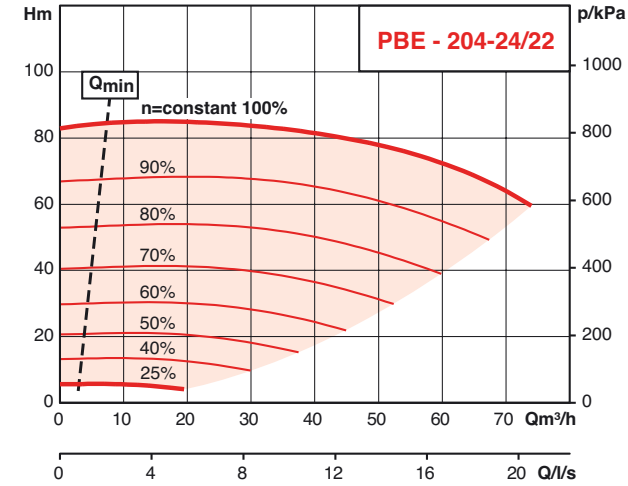

PERFORMANCES HYDRAULIQUES

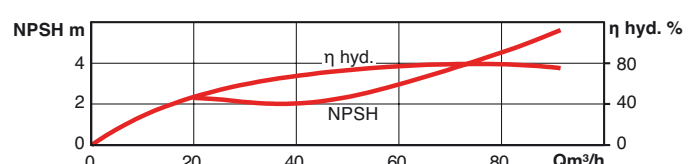
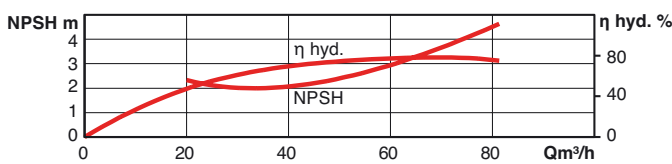
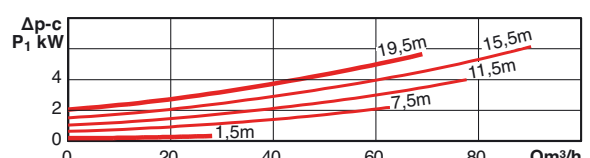
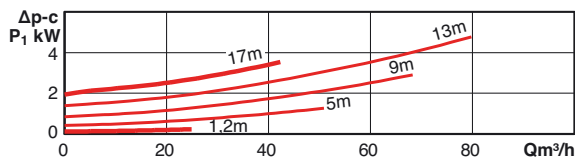
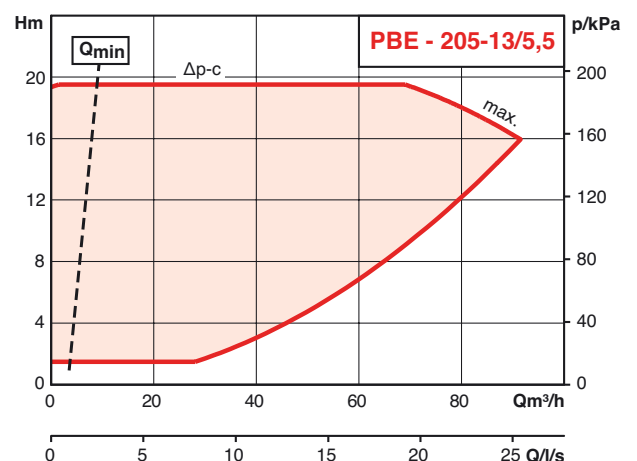
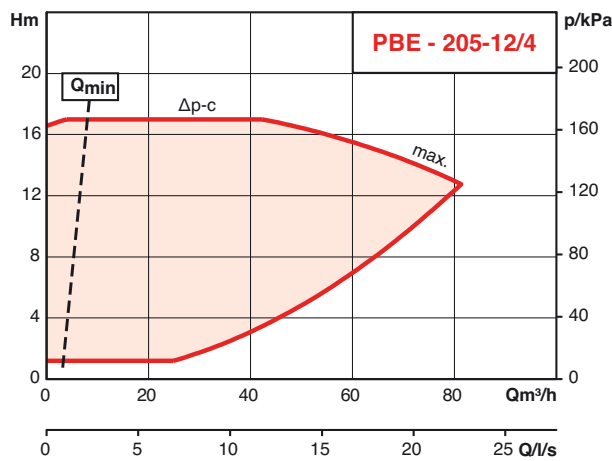
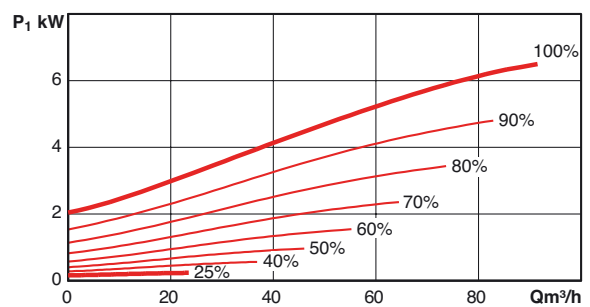
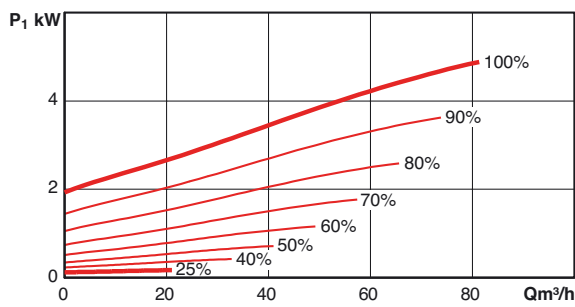
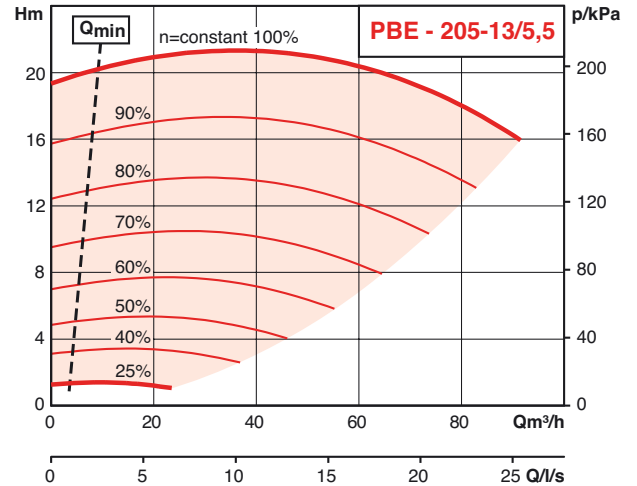
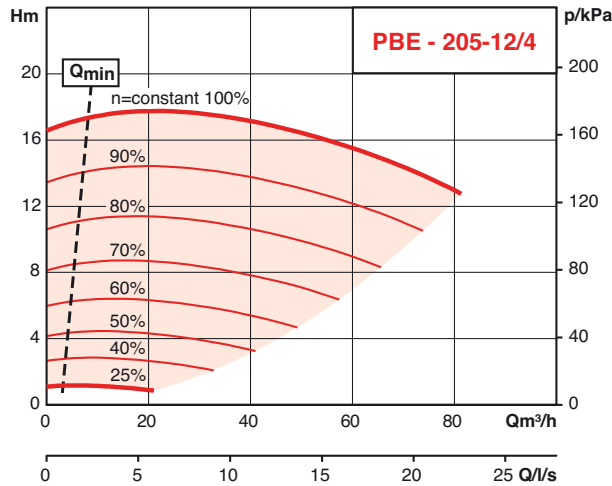

Génie climatique
Pompes à rotor sec

PERFORMANCES HYDRAULIQUES

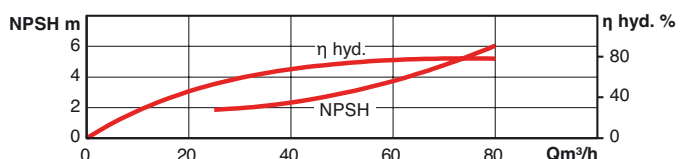
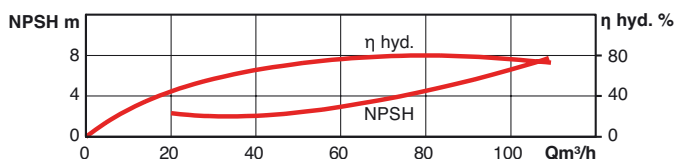
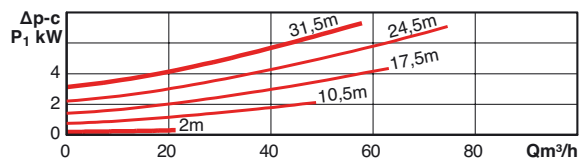
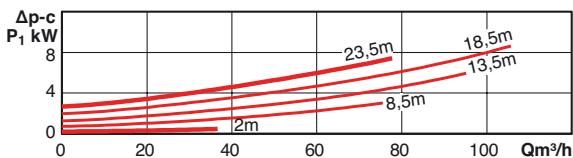
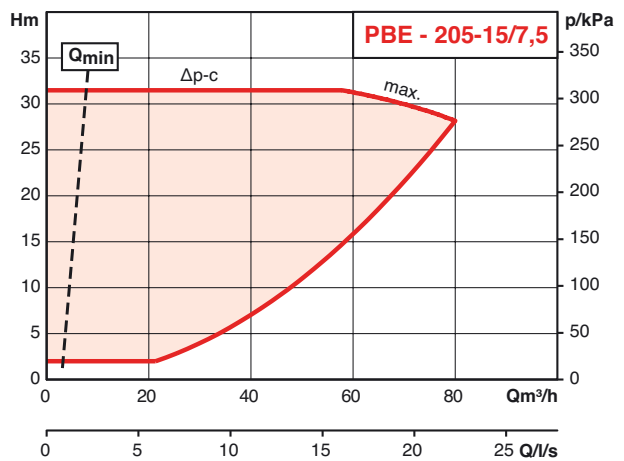
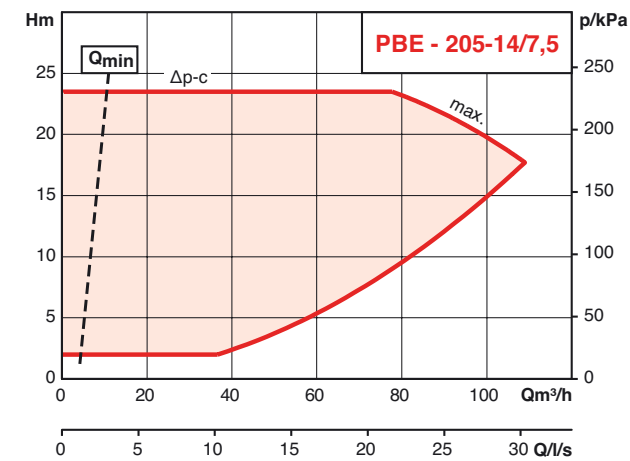
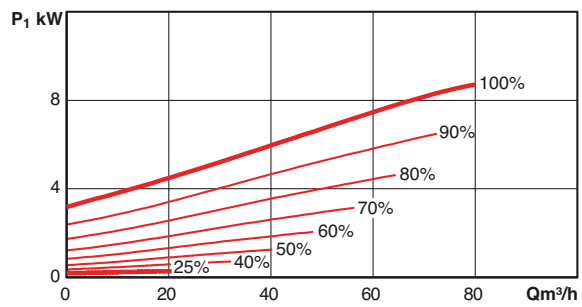
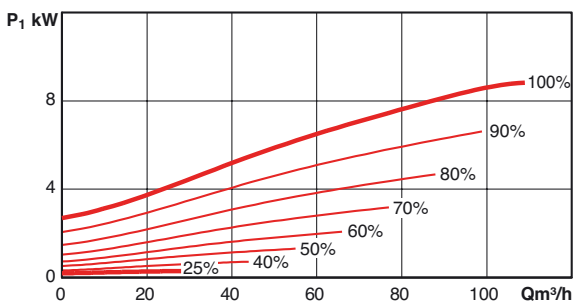
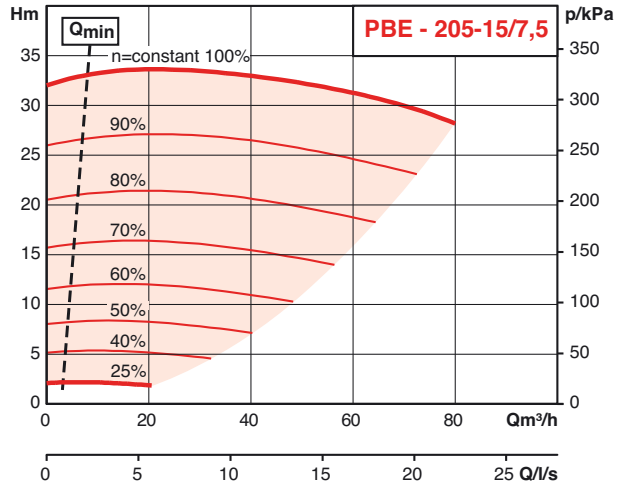
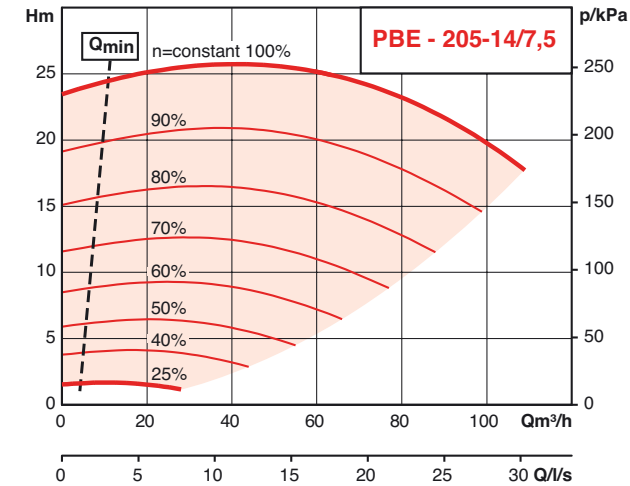

PERFORMANCES HYDRAULIQUES

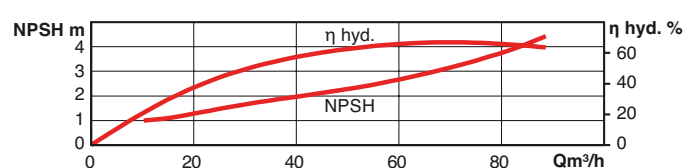
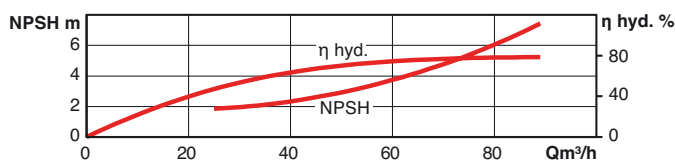
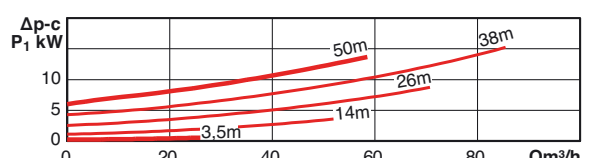
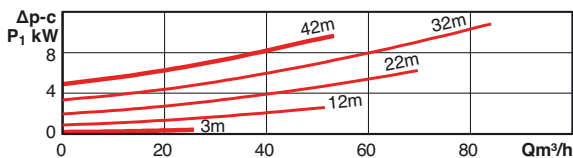
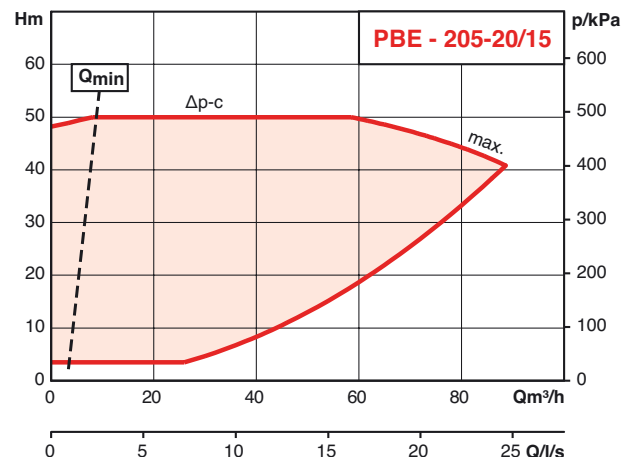
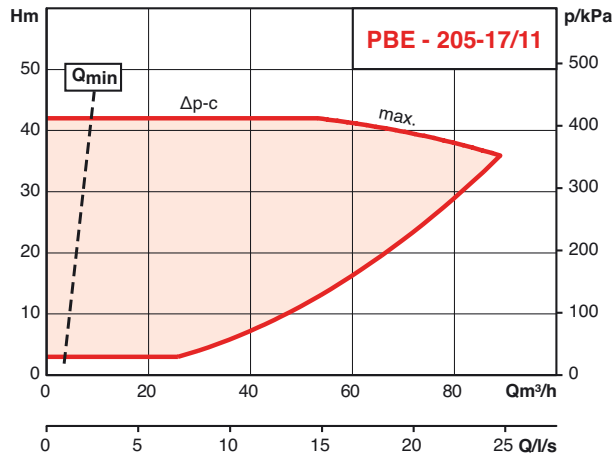
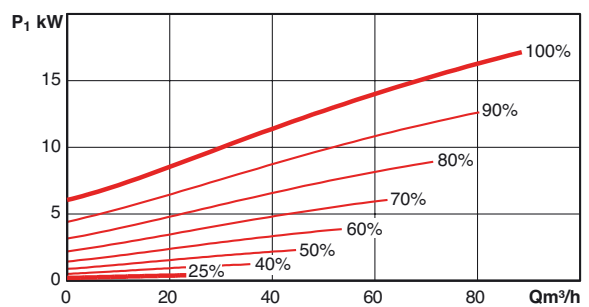
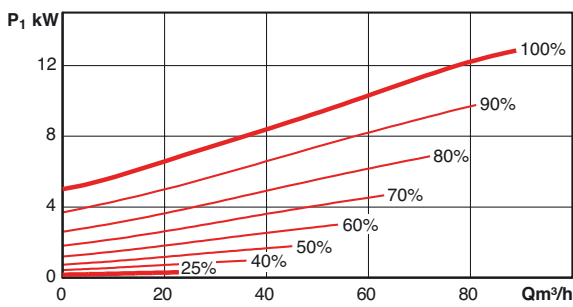
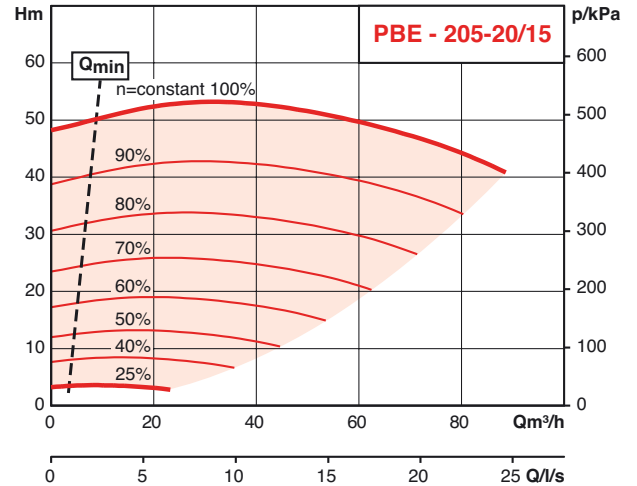
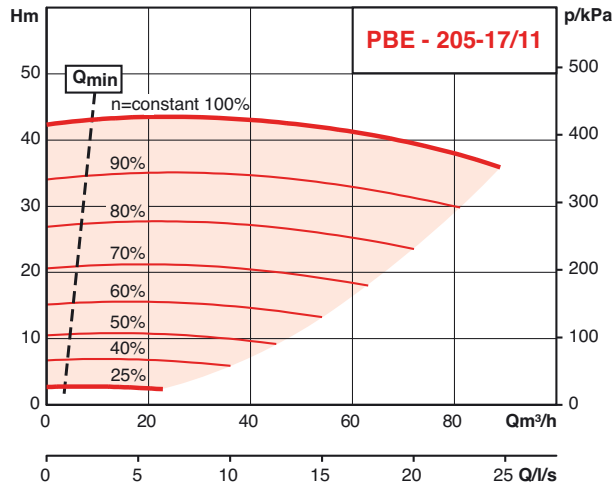

Génie climatique
Pompes à rotor sec

PERFORMANCES HYDRAULIQUES

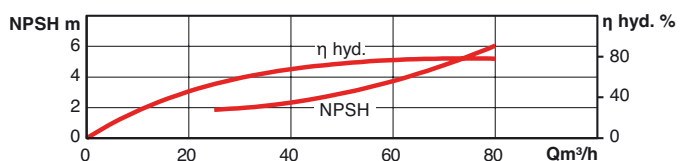
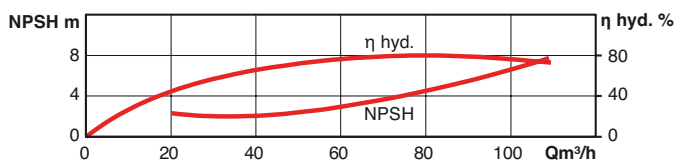
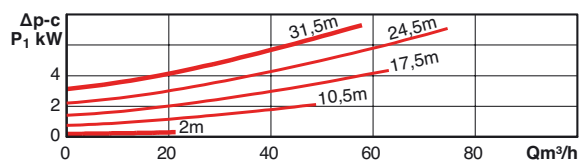
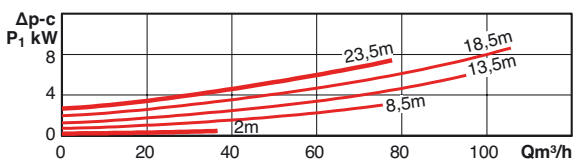
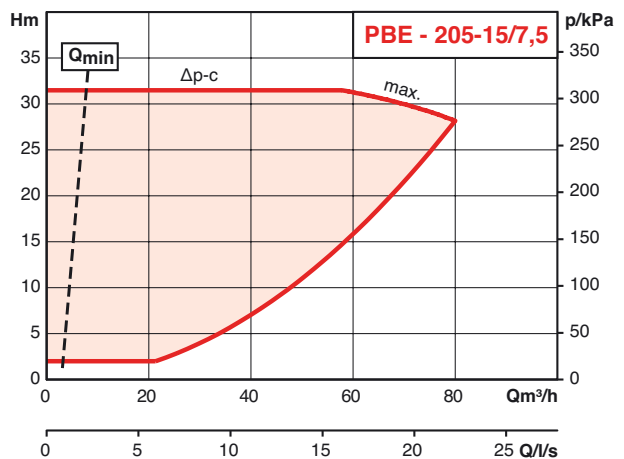
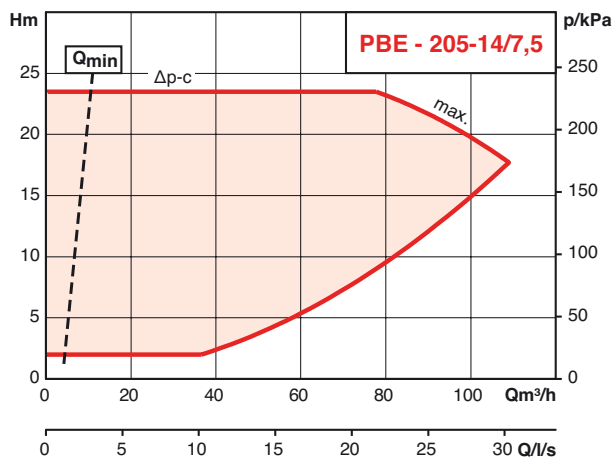
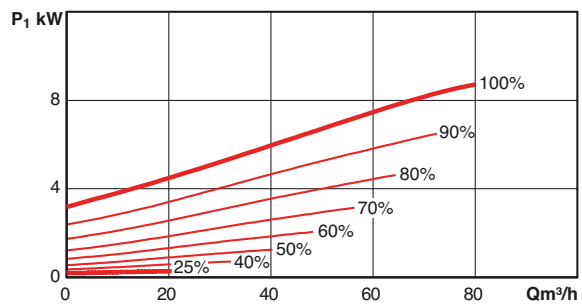
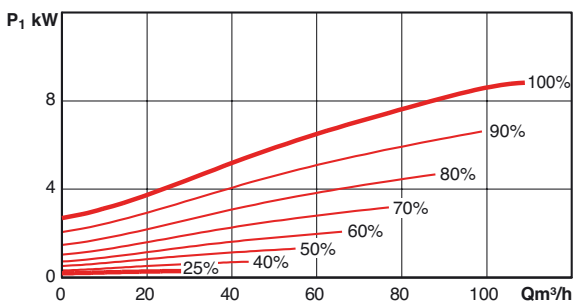
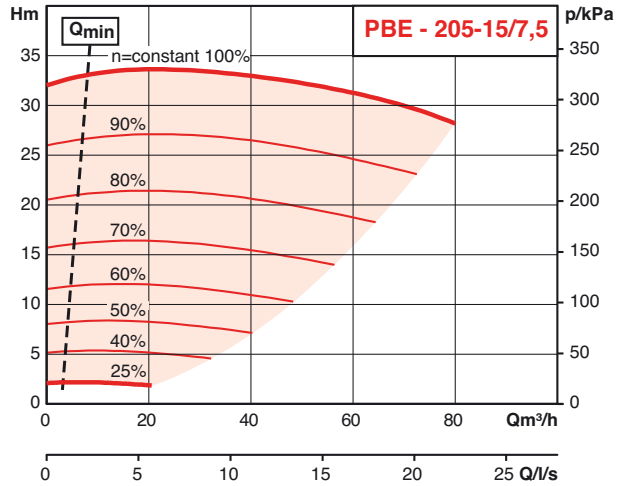
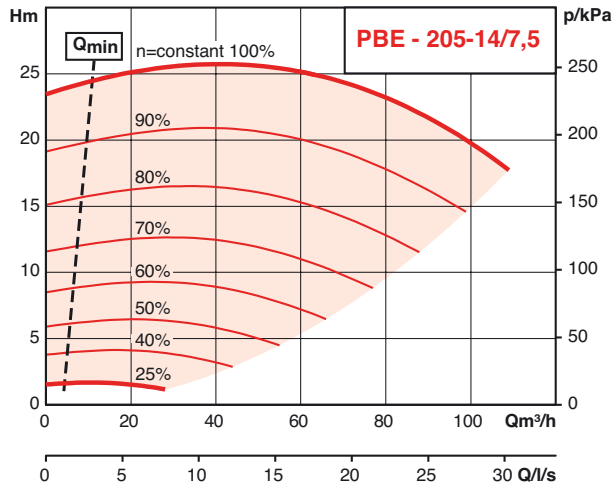

PERFORMANCES HYDRAULIQUES

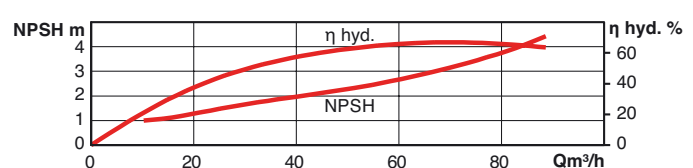
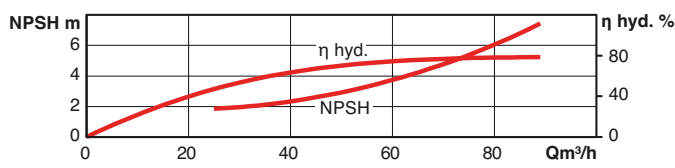
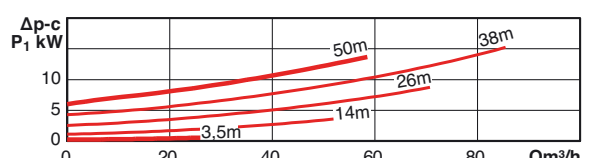
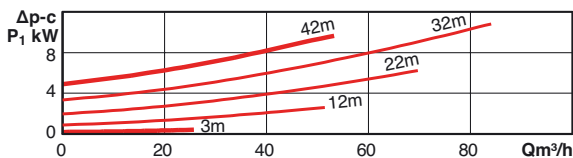
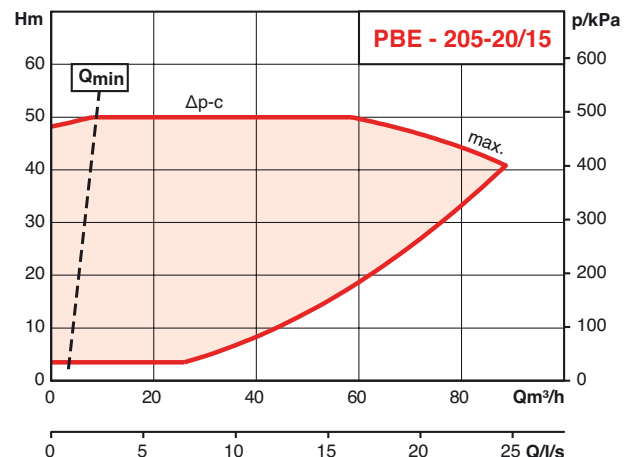
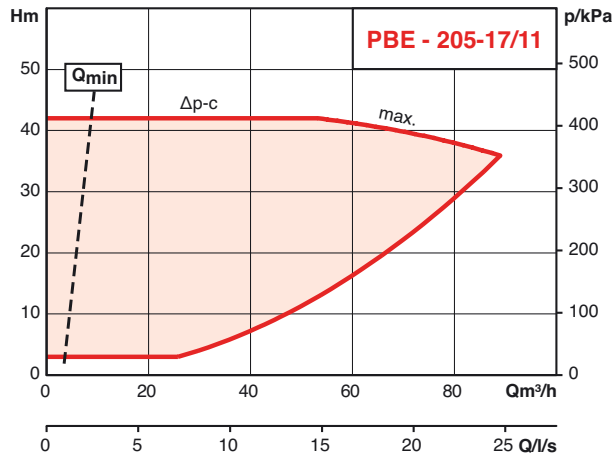
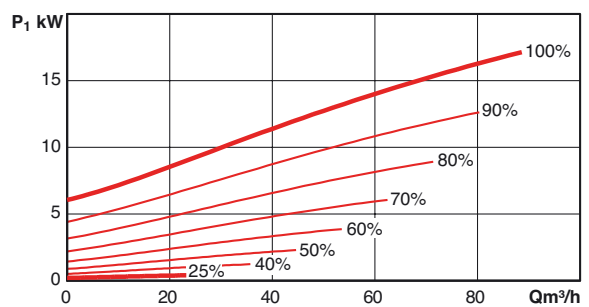
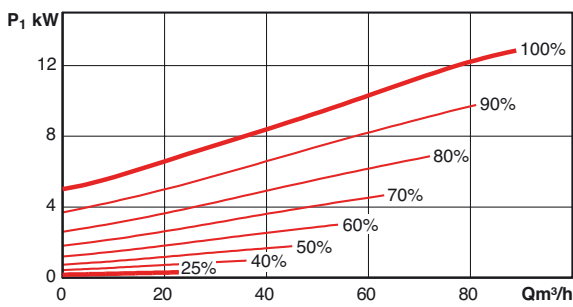
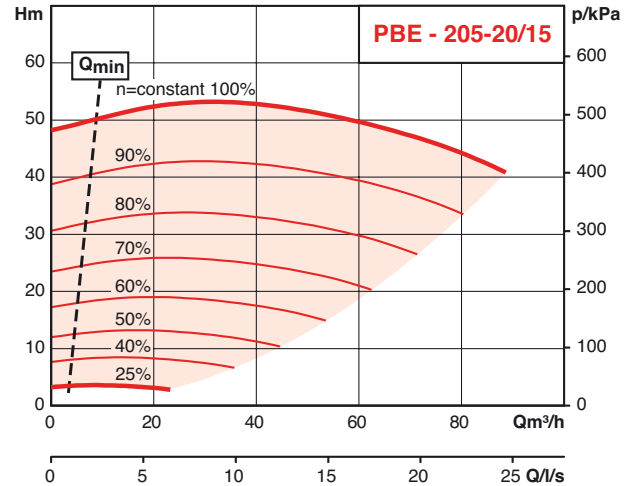
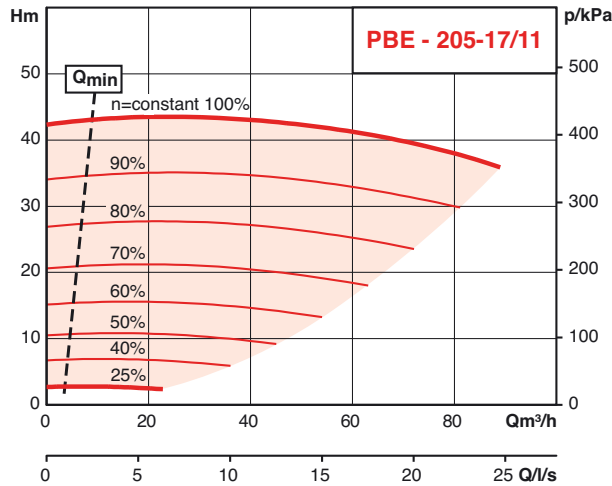

Génie climatique
Pompes à rotor sec

PERFORMANCES HYDRAULIQUES

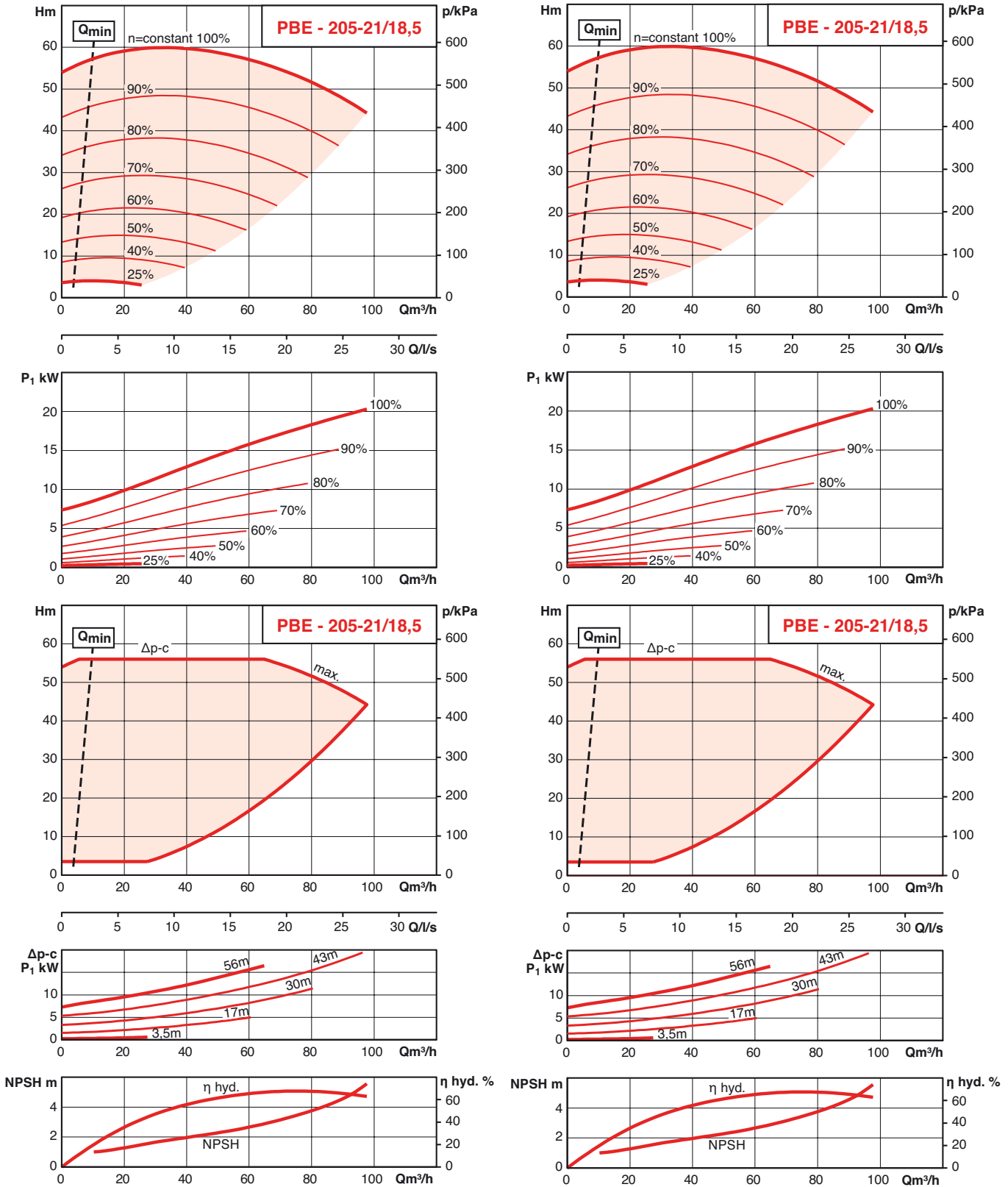

PERFORMANCES HYDRAULIQUES

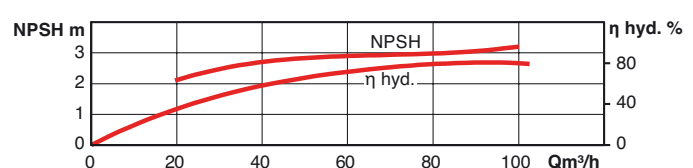
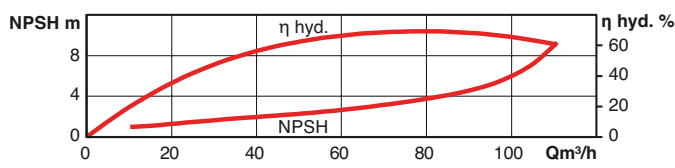
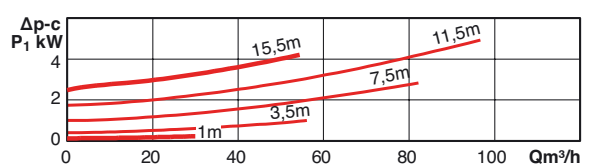
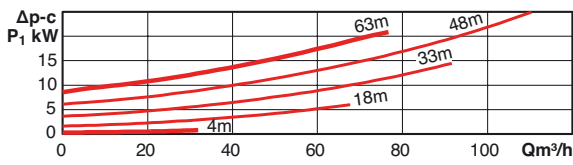
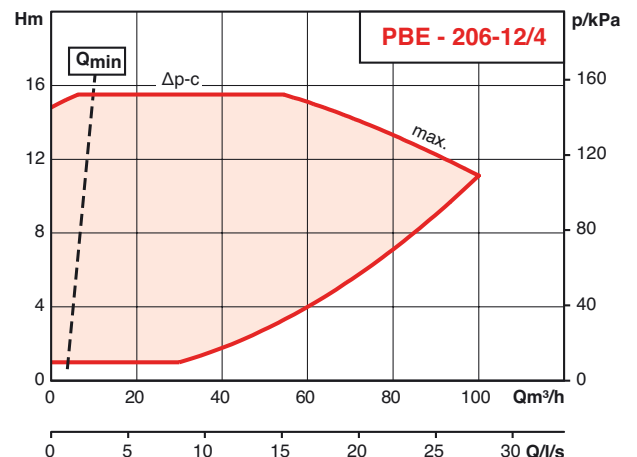
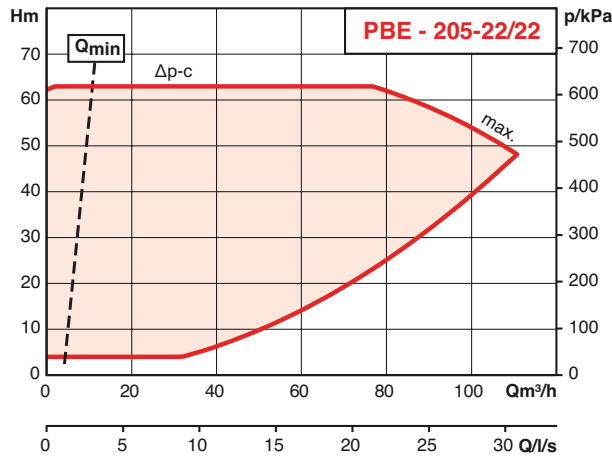
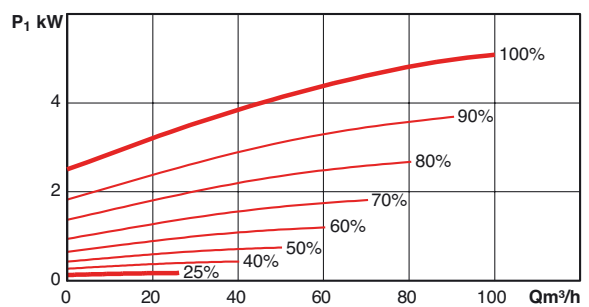
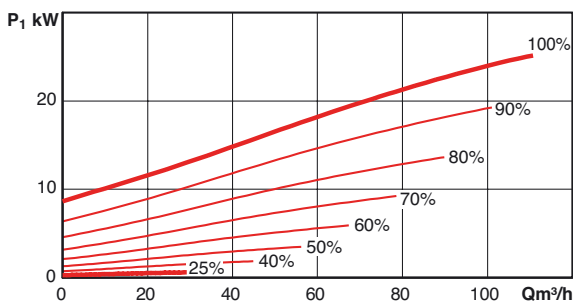
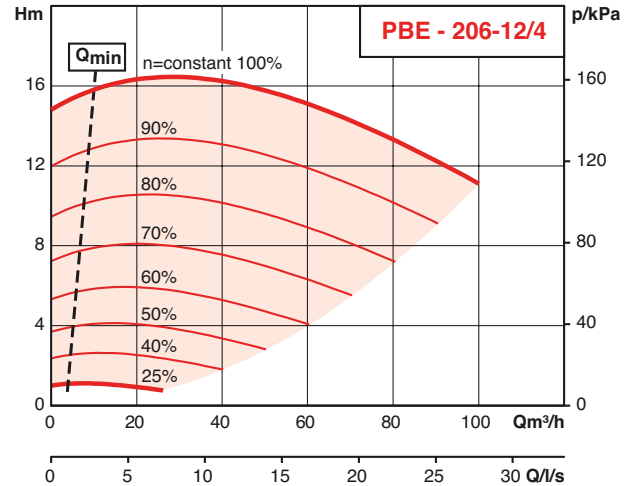
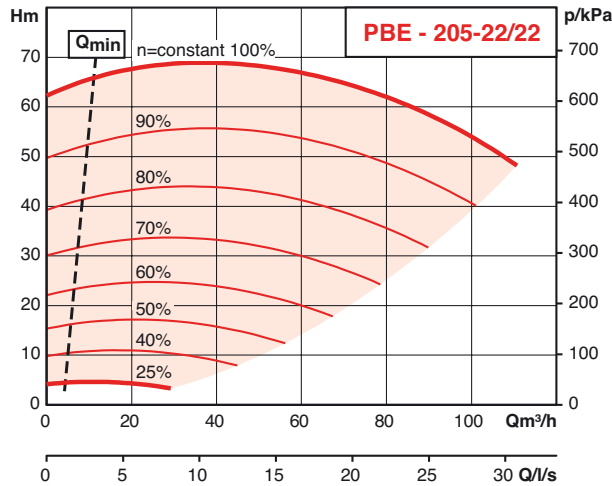

Génie climatique
Pompes à rotor sec

PERFORMANCES HYDRAULIQUES

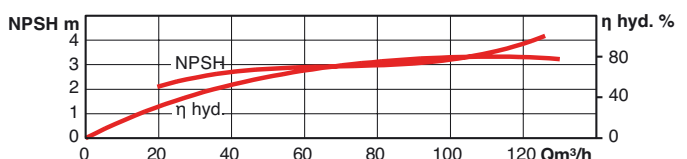
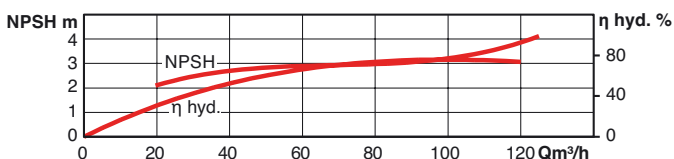
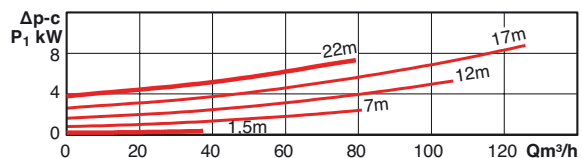
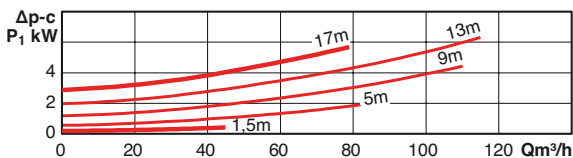
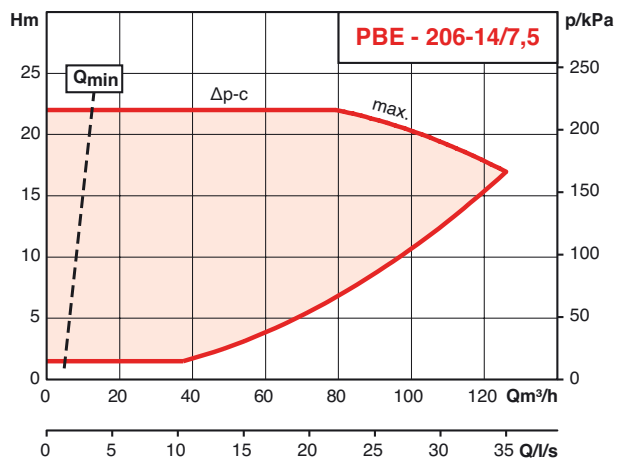
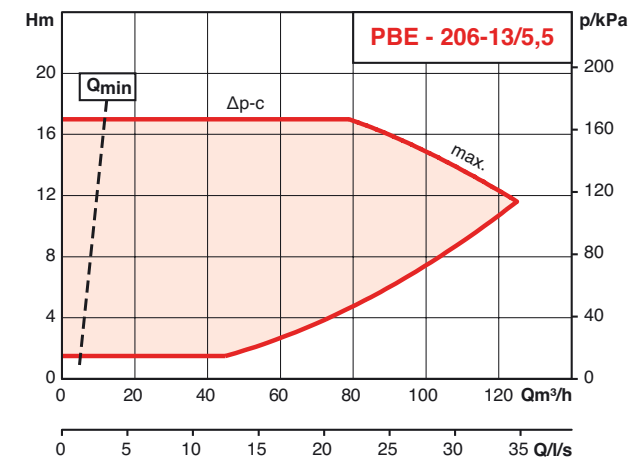
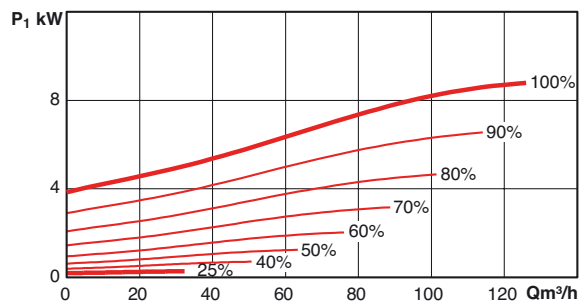
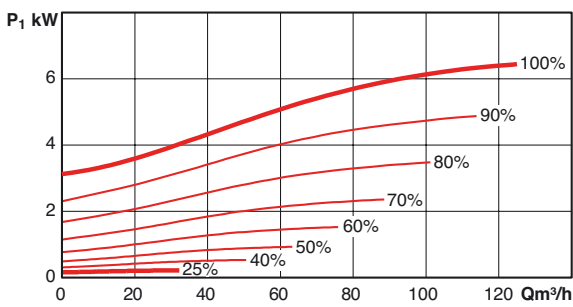
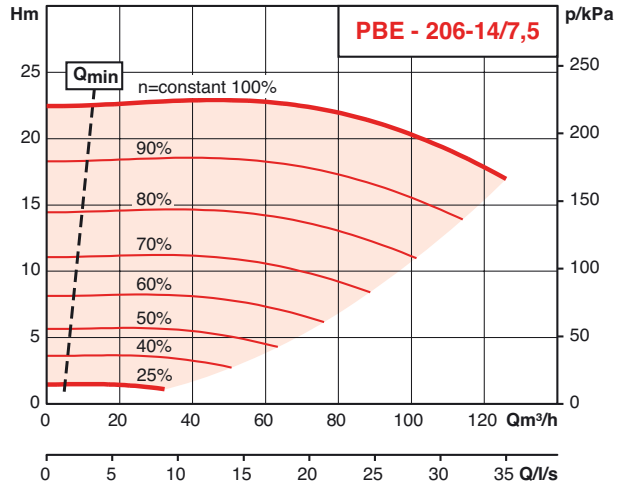
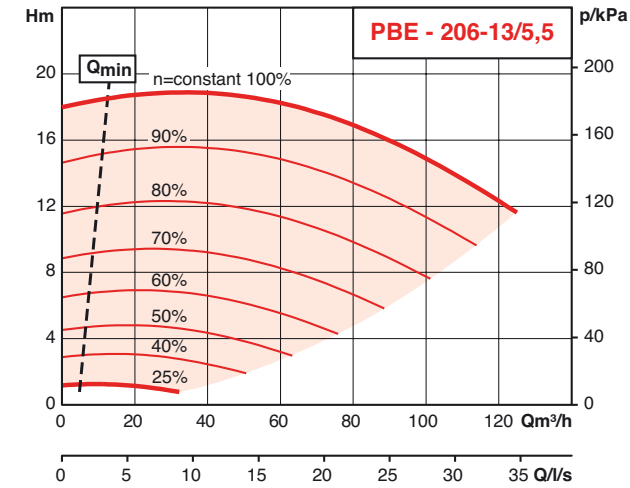

PERFORMANCES HYDRAULIQUES

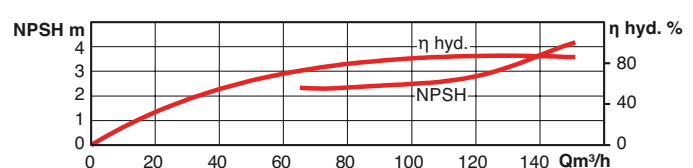
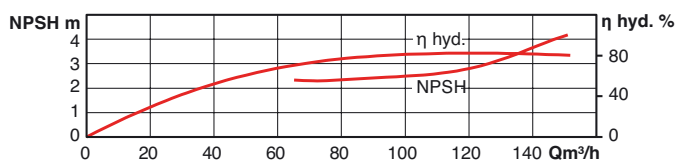
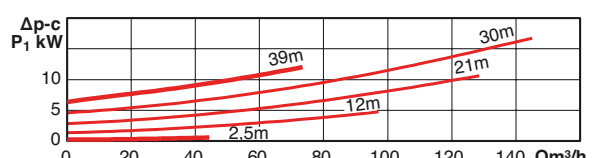
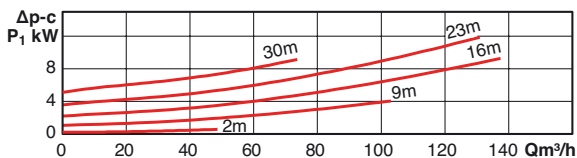
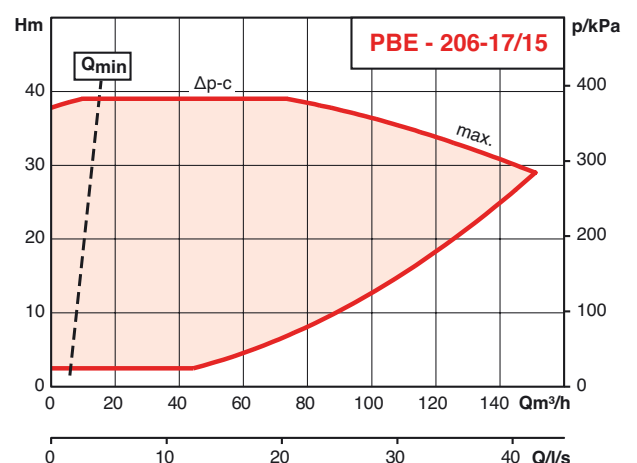
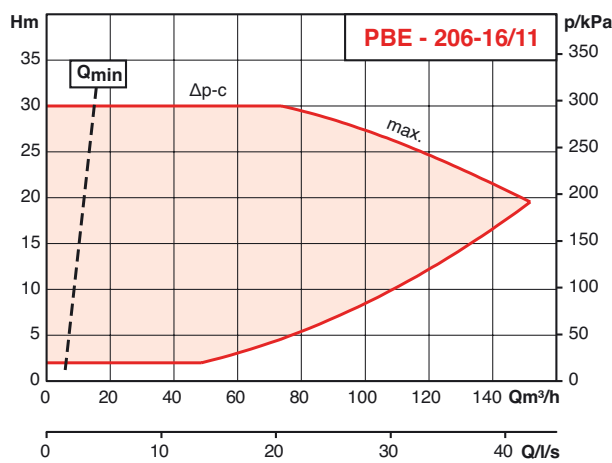
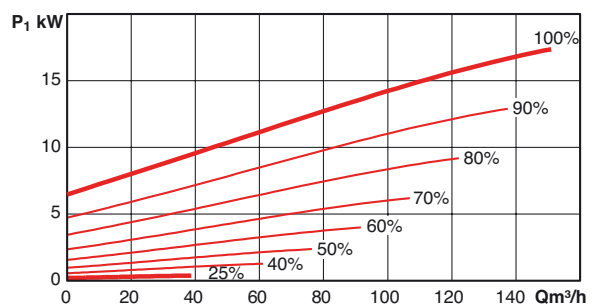
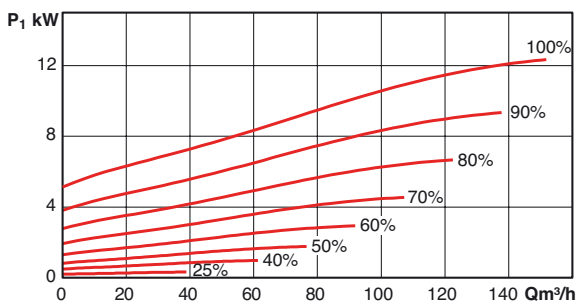
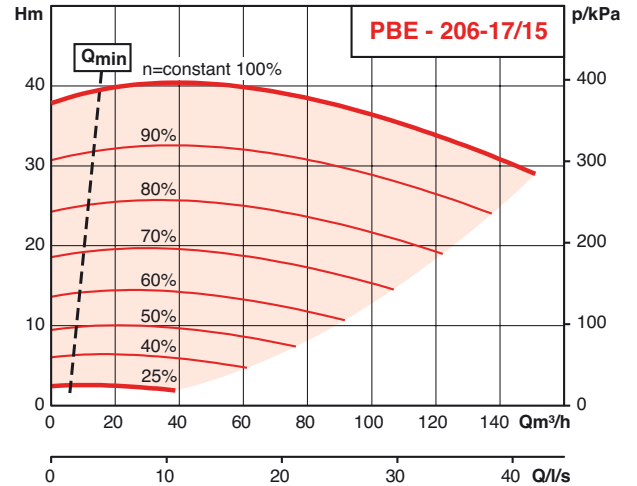
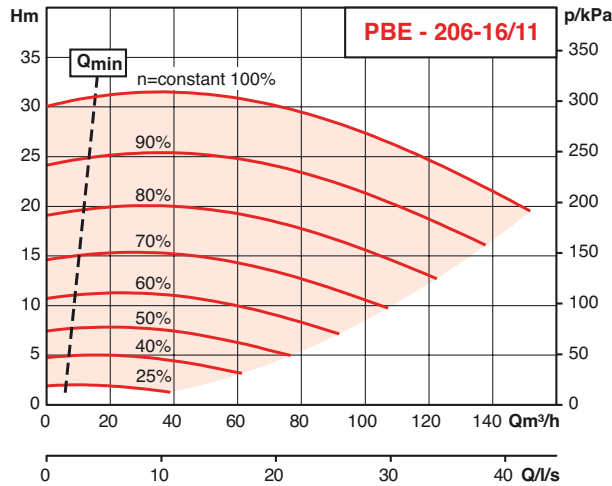

Génie climatique
Pompes à rotor sec

PERFORMANCES HYDRAULIQUES

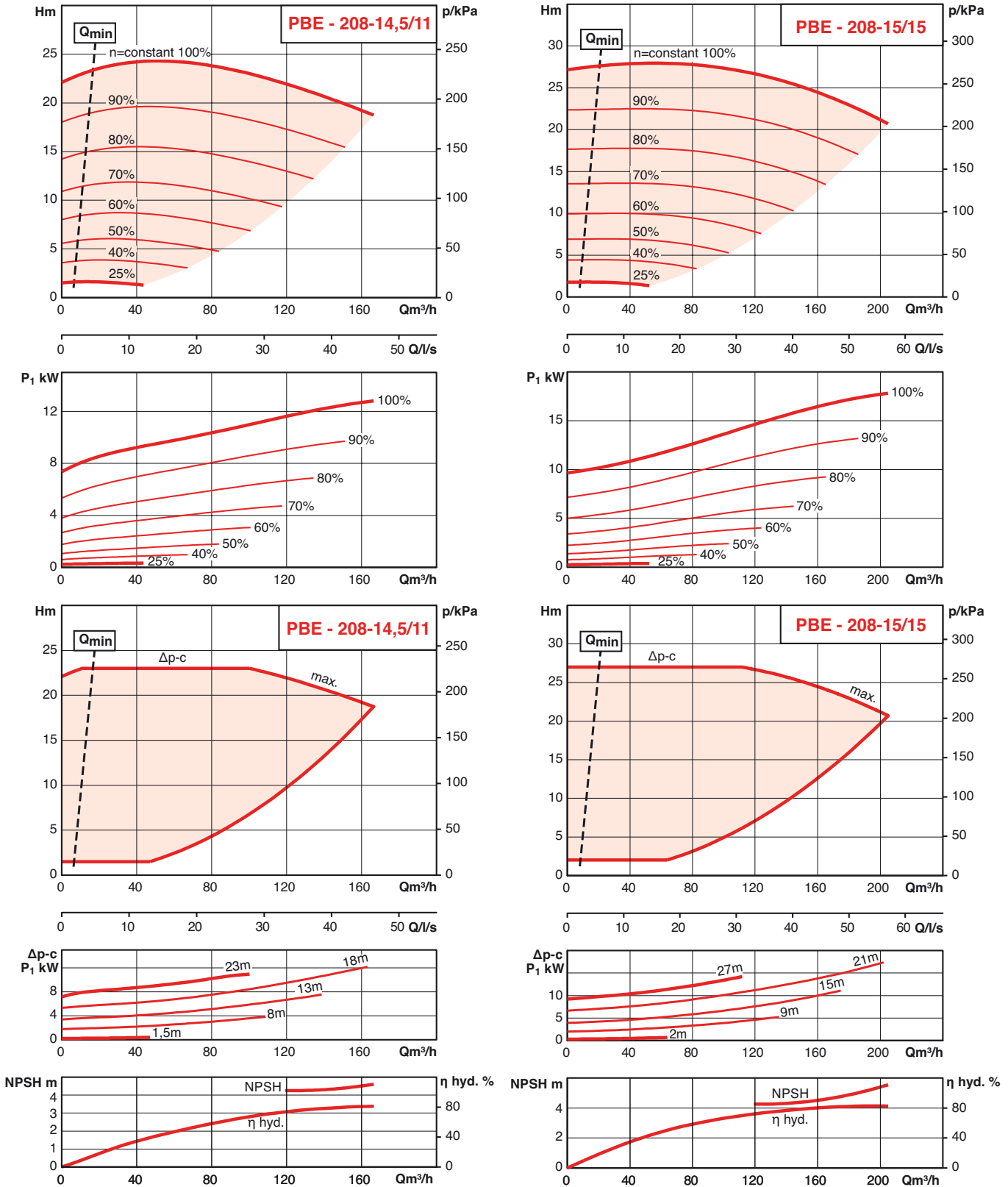

PERFORMANCES HYDRAULIQUES

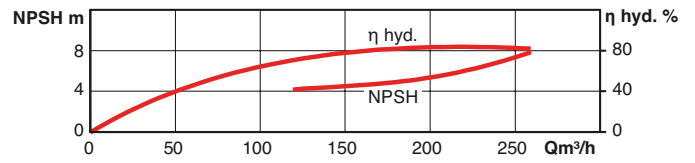
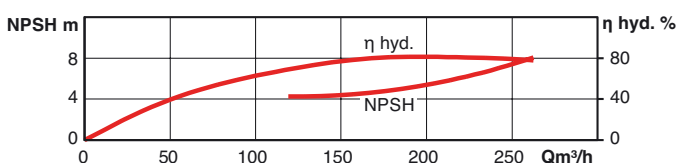
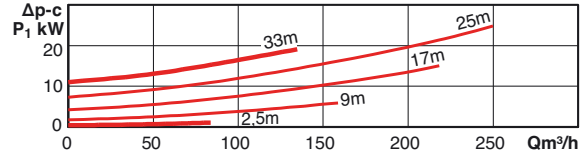
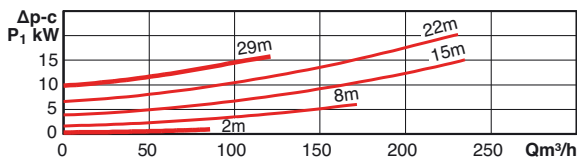
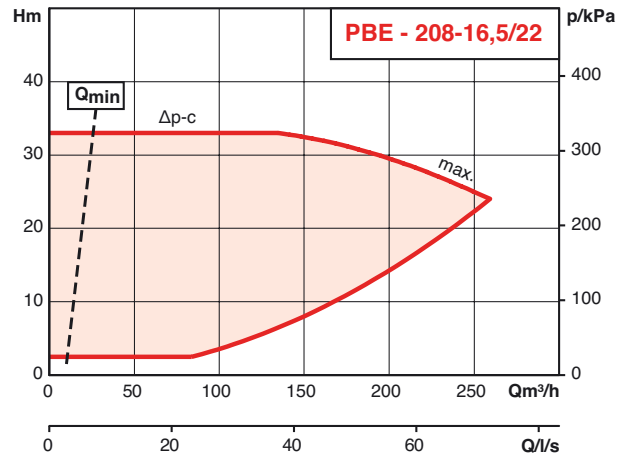
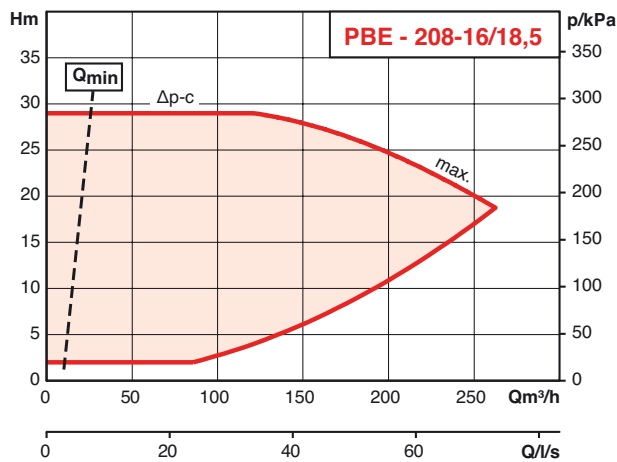
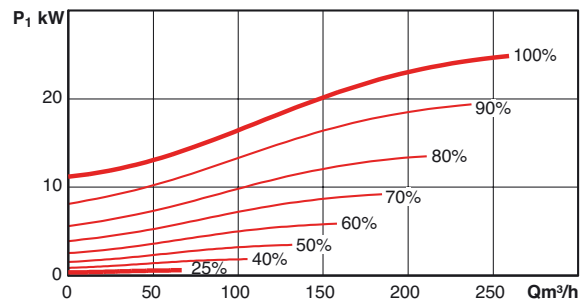
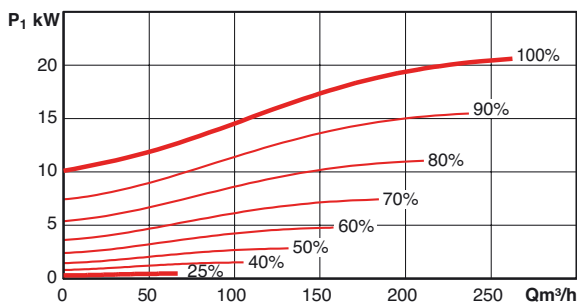
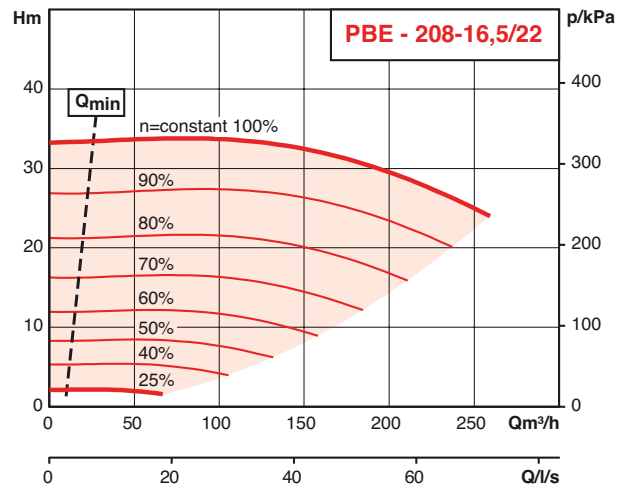
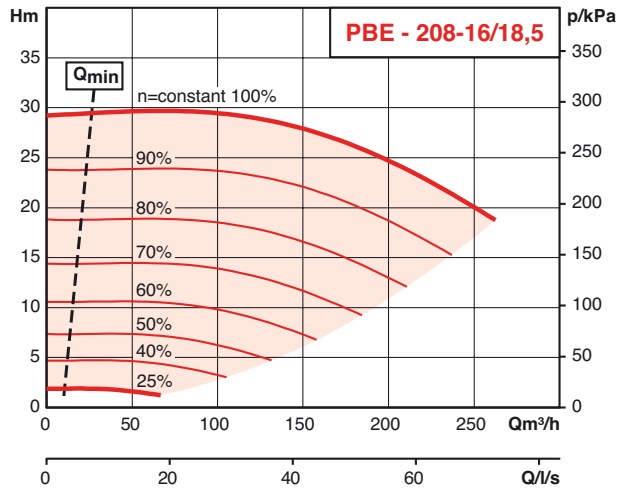

Génie climatique
Pompes à rotor sec

PERFORMANCES HYDRAULIQUES

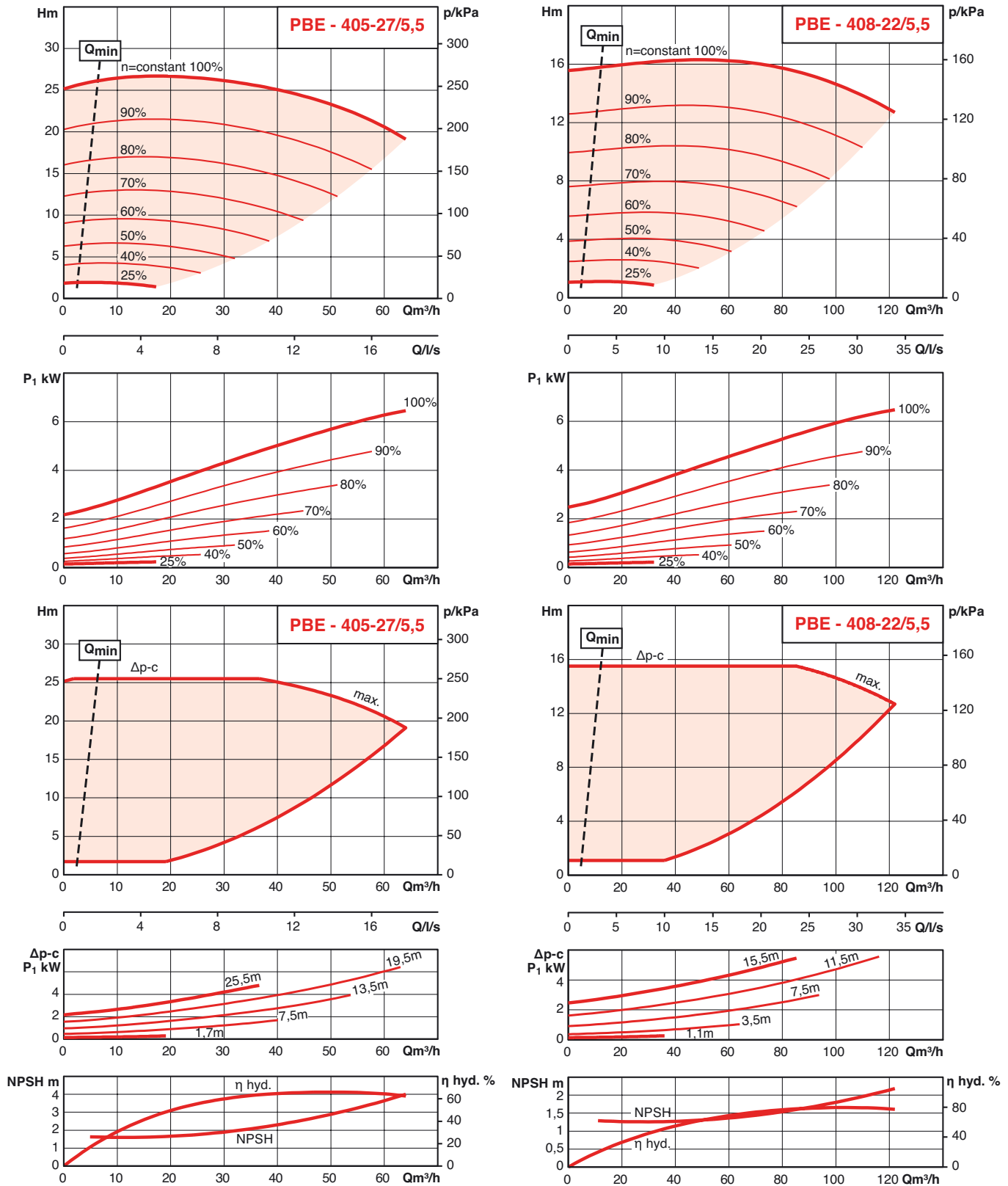

PERFORMANCES HYDRAULIQUES

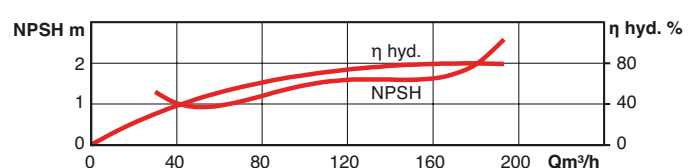
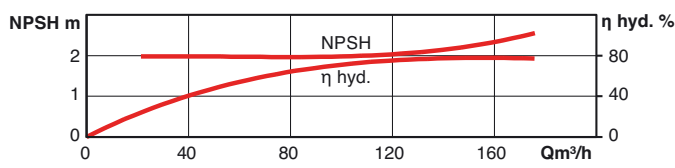
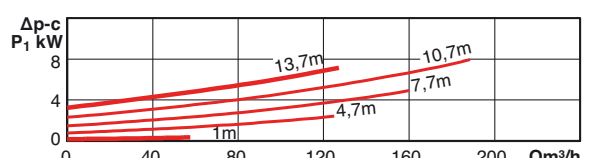
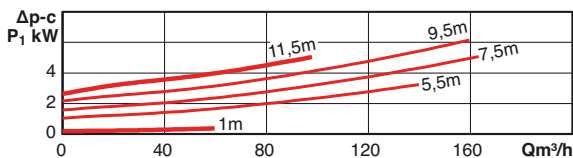
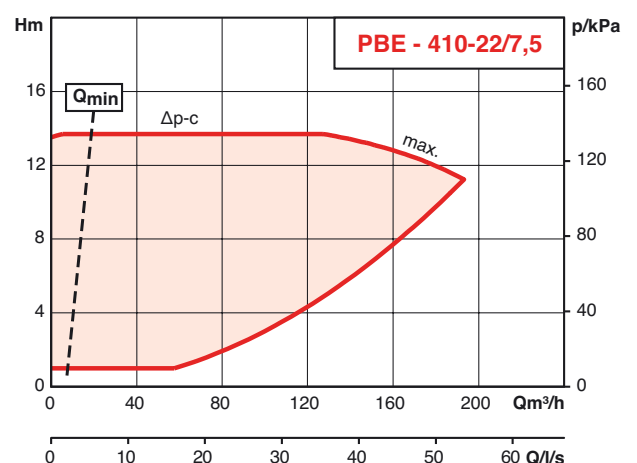
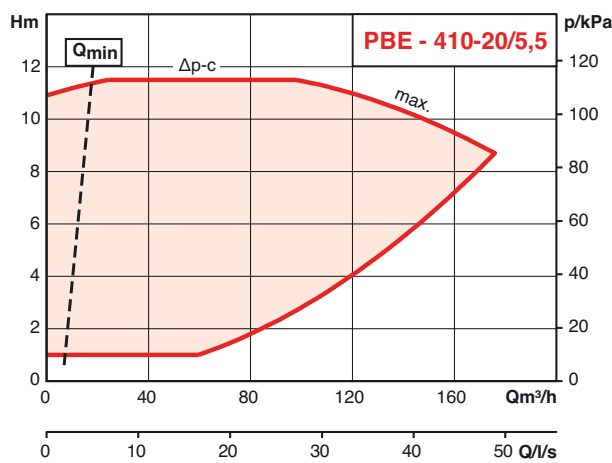
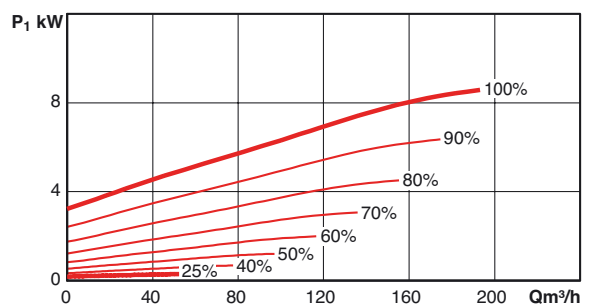
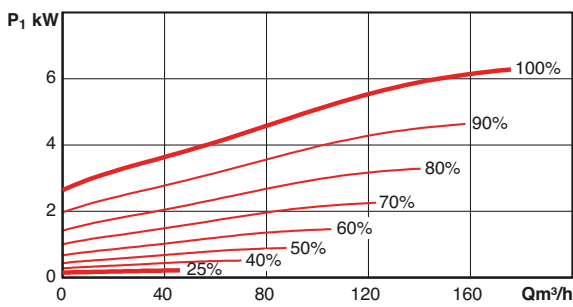
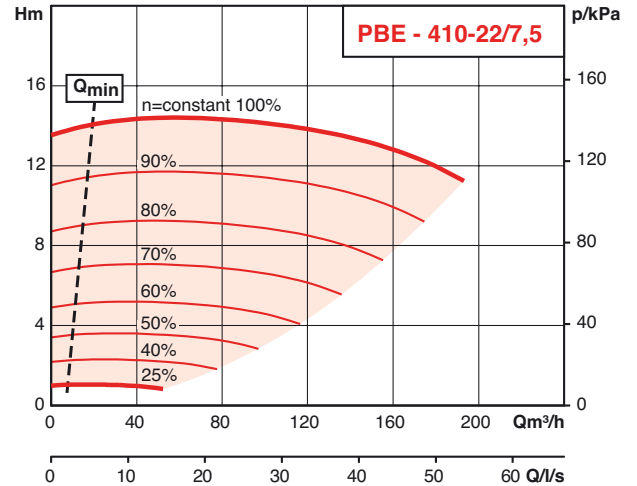
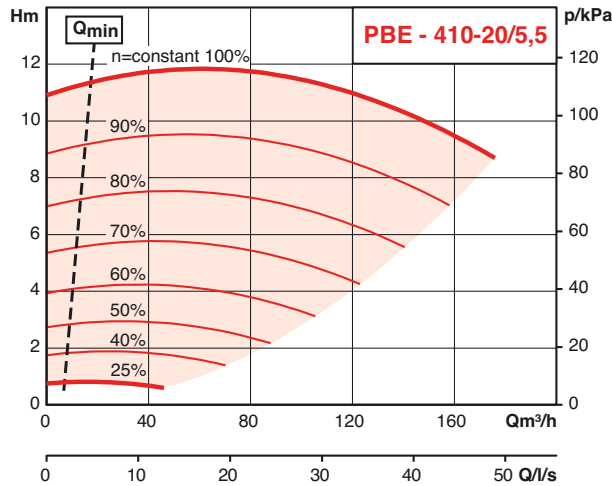

Génie climatique
Pompes à rotor sec

PERFORMANCES HYDRAULIQUES

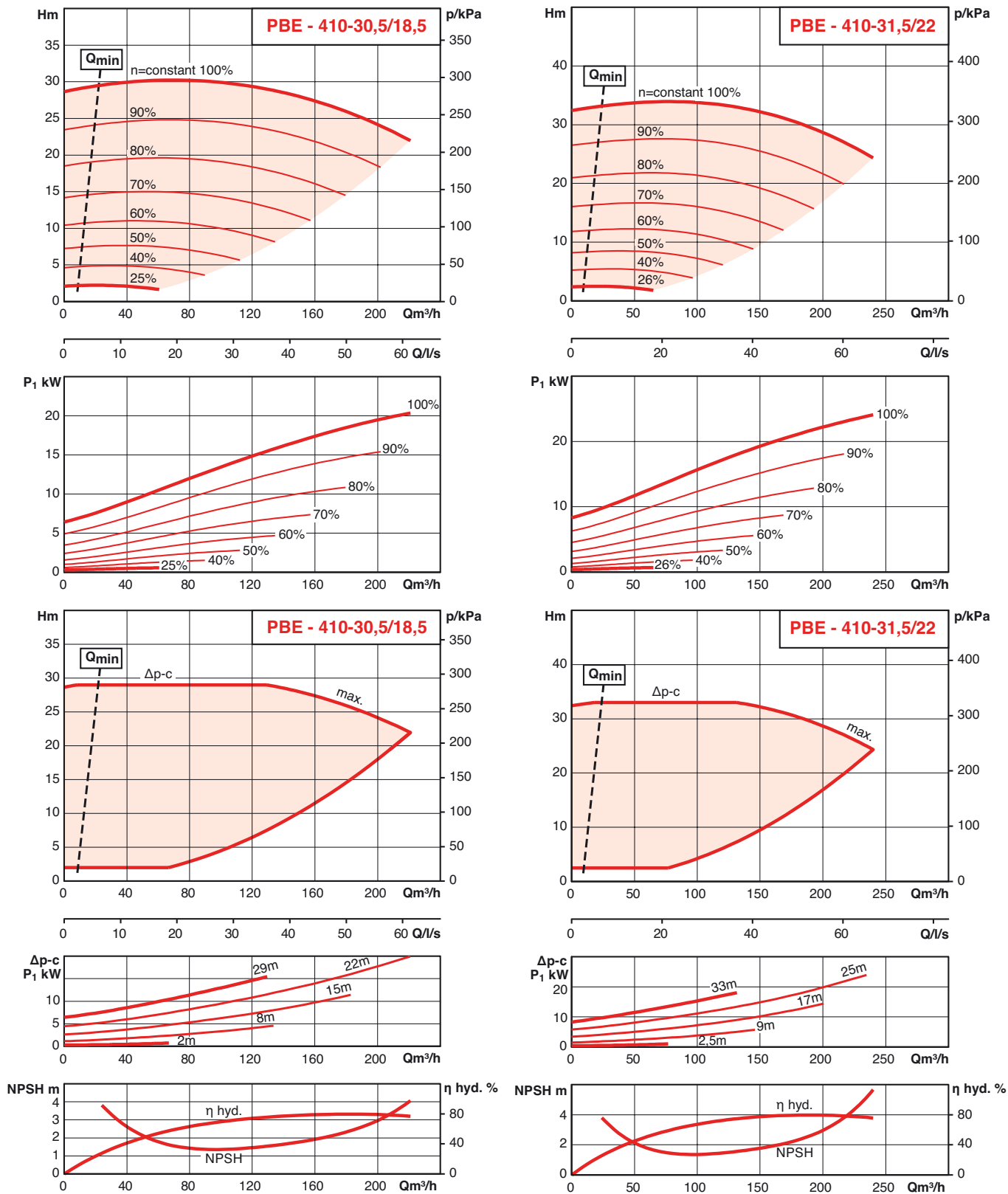

DIMENSIONS – MOTEUR ≤ 4KW

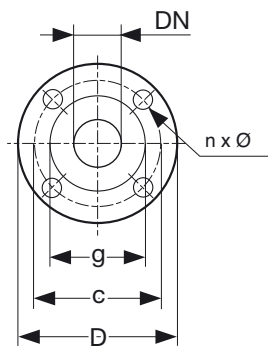
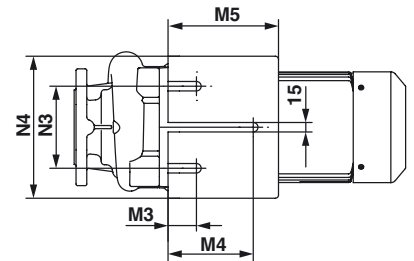
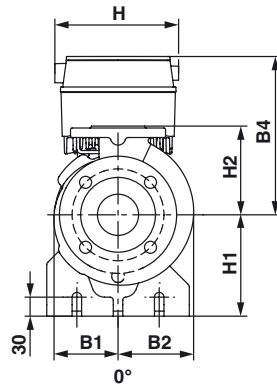
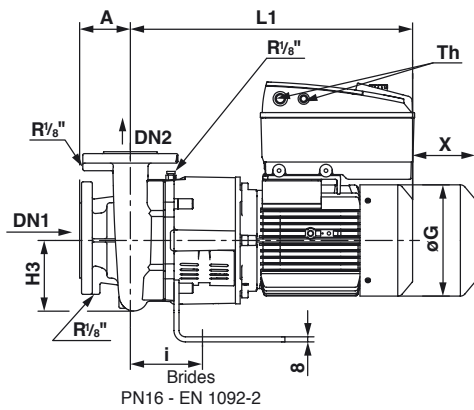

DNA	ØD	Øg	Øc	n x Ø
	mm			n x mm
50	165	99	125	4 x 19
65	185	118	145	4 x 19
80	200	132	160	8 x 19
100	220	156	180	8 x 19

DNR	ØD	Øg	Øc	n x Ø
	mm			n x mm
32	140	76	100	4 x 19
40	150	84	110	4 x 19
50	165	99	125	4 x 19
65	185	118	145	4 x 19
80	200	132	160	8 x 19

Référence article	Référence SAP	Moteur	A	L1	Ø A1	Ø G	H3	X	B max	B1	B2	B4	H	H1	H2	M3	M4	M5	N3	N4
			mm	mm	mm	mm	mm	mm	mm	mm	mm	mm	mm	mm	mm	mm	mm	mm	mm	mm
2126163	PBE203-14/2.2-R1	V1	80	447	200	177	122	95	242	113	129	240	220	160	160	47,5	137,5	185	130	210
2126164	PBE203-15/3-R1	V1	80	487,4	250	196	122	95	242	113	129	255	220	160	160	47,5	137,5	185	130	210
2126165	PBE203-16/4-R1	V1	80	504,4	250	220	122	95	242	113	129	270	220	160	160	47,5	137,5	185	130	210
2126169	PBE204-11/1.5-R1	V1	80	435	200	177	111	100	220	101	119	240	220	160	140	45	135	175	130	225
2126170	PBE204-12/2.2-R1	V1	80	445	200	177	111	100	220	101	119	240	220	160	140	45	135	175	130	225
2126171	PBE204-13/3-R1	V1	80	487	250	196	111	100	220	101	119	255	220	160	140	45	135	175	130	225
2126172	PBE204-14/4-R1	V1	80	504	250	220	111	100	220	101	119	270	220	160	140	45	135	175	130	225
2126179	PBE205-11/3-R1	V1	100	494	250	196	124	110	244	111	133	255	220	160	160	45	135	175	130	225
2126180	PBE205-12/4-R1	V1	100	511	250	220	124	110	244	111	133	270	220	160	160	45	135	175	130	225
2126189	PBE206-12/4-R1	V1	100	516	250	220	155	120	274	123	151	270	220	160	180	45	135	175	130	225

DIMENSIONS – MOTEUR ≥ 5,5KW

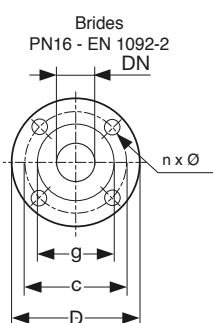
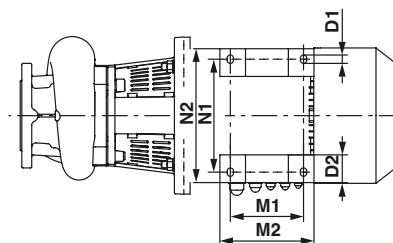
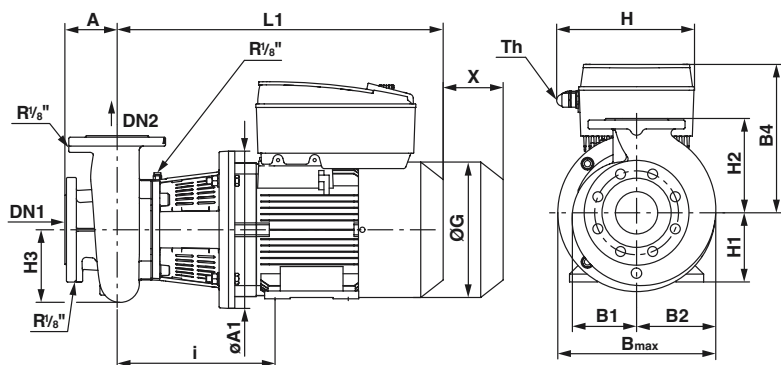

DNA	ØD	Øg	Øc	n x Ø
mm				
50	165	99	125	4 x 19
65	185	118	145	4 x 19
80	200	132	160	8 x 19
100	220	156	180	8 x 19

DNR	ØD	Øg	Øc	n x Ø
mm				
32	140	76	100	4 x 19
40	150	84	110	4 x 19
50	165	99	125	4 x 19
65	185	118	145	4 x 19
80	200	132	160	8 x 19

Référence article	Référence SAP	Moteur	A	L1	Ø A1	Ø G	H3	X	B max	B1	B2	B4	H	H1	H2	D1	D2	M1	M2	N1	N2
			mm	mm	mm	mm	mm	mm	mm	mm	mm	mm	mm	mm	mm	mm	mm	mm	mm	mm	mm
2126166	PBE203-17/5.5-R1	B35	80	572	325	266	122	95	310	113	129	303	260	132	160	12	53	140	180	216	256
2126167	PBE203-21/7.5-R1	B35	80	579	325	266	122	95	300	113	129	303	260	132	160	12	53	140	180	216	256
2126168	PBE203-22/11-R1	B35	80	708	350	302	122	95	350	113	129	427	320	160	160	15	65	210	305	254	310
2126173	PBE204-16/5.5-R1	B35	80	573	325	266	132	100	310	120	135	303	260	132	160	12	53	140	180	216	256
2126174	PBE204-17/7.5-R1	B35	80	573	325	266	132	100	325	120	135	303	260	132	160	12	53	140	180	216	256
2126175	PBE204-18/7.5-R1	B35	100	586	325	266	145	100	300	145	151	303	260	132	180	12	53	140	180	216	256
2126176	PBE204-21/11-R1	B35	100	715	350	302	145	100	350	145	151	427	320	160	180	15	65	210	305	254	310
2126177	PBE204-22/15-R1	B35	100	715	350	302	145	100	350	145	151	427	320	160	180	15	65	210	305	254	310
2113494	PBE204-23/18.5-R1	B35	100	782	350	302	174	110	350	174	174	427	320	160	225	15	65	254	305	254	310
2126178	PBE204-24/22-R1	B35	100	782	350	302	174	110	350	174	174	427	320	160	225	15	65	254	305	254	310
2126181	PBE205-13/5.5-R1	B35	100	583	325	266	124	110	300	111	133	303	260	132	160	12	53	140	180	216	256
2126182	PBE205-14/7.5-R1	B35	100	583	325	266	124	110	300	111	133	303	260	132	160	12	53	140	180	216	256
2126183	PBE205-15/7.5-R1	B35	100	581	325	266	152	120	325	127	147	303	260	132	180	12	53	140	180	216	256
2126184	PBE205-17/11-R1	B35	100	718	350	302	152	120	350	127	147	427	320	160	180	15	65	210	305	254	310
2126185	PBE205-20/15-R1	B35	100	715	350	302	159	110	350	153	172	427	320	160	200	15	65	210	305	254	310
2126186	PBE205-21/18.5-R1	B35	100	778	350	302	159	110	350	153	172	427	320	160	200	15	65	254	305	254	310
2126187	PBE205-22/22-R1	B35	100	778	350	302	159	110	350	153	172	427	320	180	200	15	65	254	305	254	310
2126188	PBE405-27/5.5-R1	B35	100	593	300	266	179	110	360	174	186	303	260	132	225	12	53	140	180	216	256
2126190	PBE206-13/5.5-R1	B35	100	617	325	266	155	120	300	123	151	303	260	132	180	12	53	140	180	216	256
2126191	PBE206-14/7.5-R1	B35	100	623	325	266	155	120	300	123	151	303	260	132	180	12	53	140	180	216	256
2126192	PBE206-16/11-R1	B35	100	728	350	302	155	120	350	136	162	427	320	160	200	15	65	210	305	254	310
2126193	PBE206-17/15-R1	B35	100	728	350	302	155	120	350	136	162	427	320	160	200	15	65	210	305	254	310
2126197	PBE208-14.5/11-R1	B35	125	735	350	302	178	135	380	160	196	427	320	160	225	15	65	210	305	254	310
2126198	PBE208-15/15-R1	B35	125	735	350	302	178	135	380	160	196	427	320	160	225	15	65	210	305	254	310
2126199	PBE208-16/18.5-R1	B35	125	735	350	302	178	135	380	160	196	427	320	160	225	15	65	254	305	254	310
2126200	PBE208-16.5/22-R1	B35	125	735	350	302	178	135	380	160	196	427	320	180	225	15	65	254	305	254	310
2126201	PBE408-22/5.5-R1	B35	125	605	300	266	178	120	367	170	197	303	260	132	250	12	53	140	180	216	256
2126204	PBE410-20/5.5-R1	B35	125	618	300	266	196	120	387	176	211	303	260	132	280	12	53	140	180	216	256
2126205	PBE410-22/7.5-R1	B35	125	618	300	266	196	120	387	176	211	303	260	132	280	12	53	140	180	216	256
2126208	PBE410-30.5/18.5-R1	B35	140	837	350	370	250	120	560	263	297	475	320	160	315	15	70	241	342	279	339
2126209	PBE410-31.5/22-R1	B35	140	837	350	370	250	120	560	263	297	475	320	160	315	15	70	279	342	279	339