

OPERATING LIMITS

Max. flow rates up to:	200 m ³ /h
Head up to:	100 mCL
Max. operating pressure:	16 bar
Temperature range:	-20°C to +120°C
DN hydraulics:	DNS: 50 to 125 DND: 32 to 100
Max. viscosity:	150 cSt

NORMA V

LINESHAFT CENTRIFUGAL PUMPS (NFE 44-111), ENGJL 250 CAST IRON Clear or slightly charged fluids

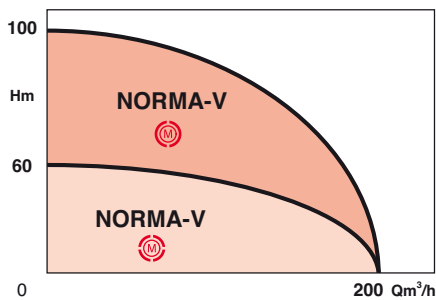

APPLICATIONS

Pumping of clear or slightly polluted liquids in the petrochemical and effluent treatment sectors.

Fixed stripping units for miscellaneous products in tanks, reservoirs, cisterns, supply of distribution loops, equipment for automatic cycle machines, paint booths, tanks...

ADVANTAGES

- Reduced maintenance
- No mechanical seal
- No priming problem
- Interchangeable standard motor.
- Semi-elastic coupling for the VTM version

IE2

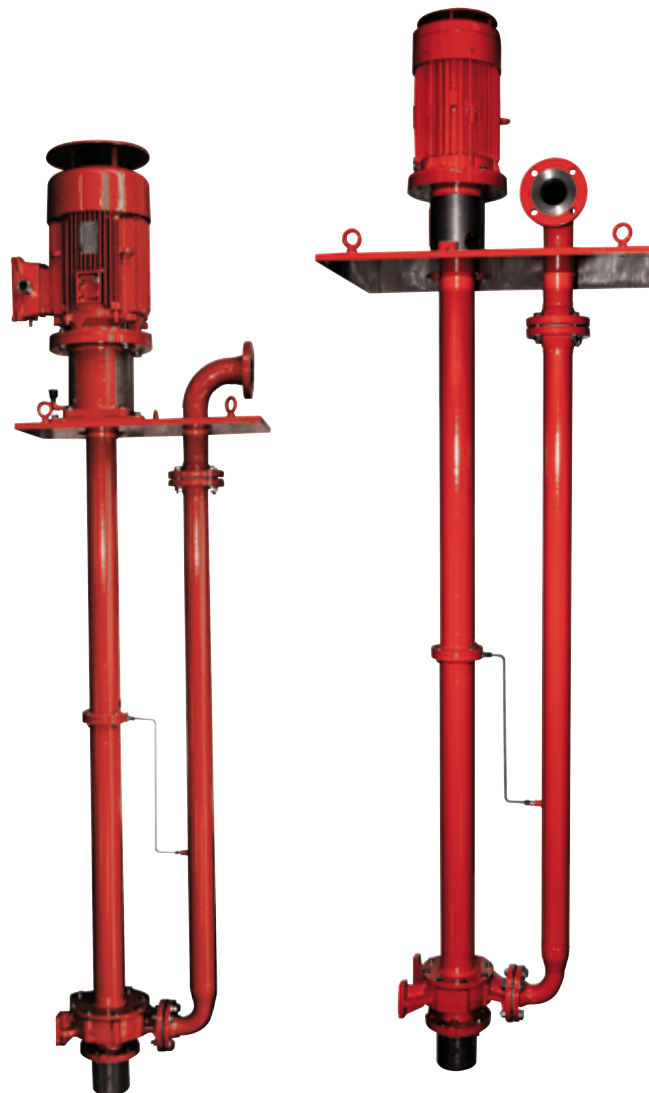

NORMA V

DESIGN

• Hydraulic part

- Centrifugal
- Single-stage, lineshaft discharge
- Axial suction with piping on specification:
 - Piping option above or below the mating plate;
 - Flange option PN 10/16 according to ANSI 150 (PN 20);
 - Custom mounting layout;
 - Optional explosion-proof float switch;
 - Optional external lubrication of bearings (grease) or lubrication by pumped fluid.

• Line-shaft construction

- VCS : adjustable base and rigid coupling
- VEM: fixed base and rigid coupling
- VTM: fixed base and bearing assembly (semi-elastic coupling)

• Standard motor

- Form : B 14 / V1
- Speed : 1450 rpm
2900 rpm
- Voltage : 230 - 400 V
- Frequency : 50Hz - (Option 60Hz)
- Insulating class : 155 (F)
- Protection index : IP 55
- Option : Explosion-proof (Ex dII BT4)

STANDARD CONSTRUCTION

Main parts	Material
Pump casing	ENGJL 250
Impeller	ENGJL 250
Pump shaft	Z20C13
Spacer column(s)	Fabricated steel
Bearings	Bronze
Lantern	SiC
	ENGJL 250

IDENTIFICATION

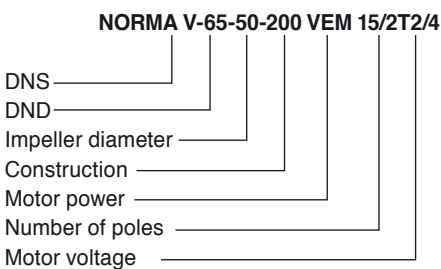

HYDRAULIC PRESELECTION GUIDE, 4-POLE - 1,450 RPM

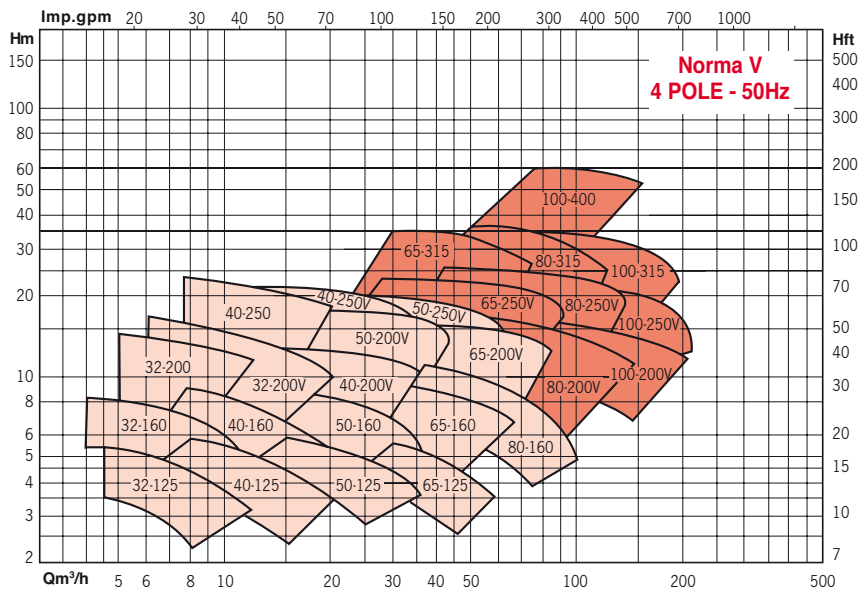

HYDRAULIC PRESELECTION GUIDE, 2-POLE - 2,900 RPM

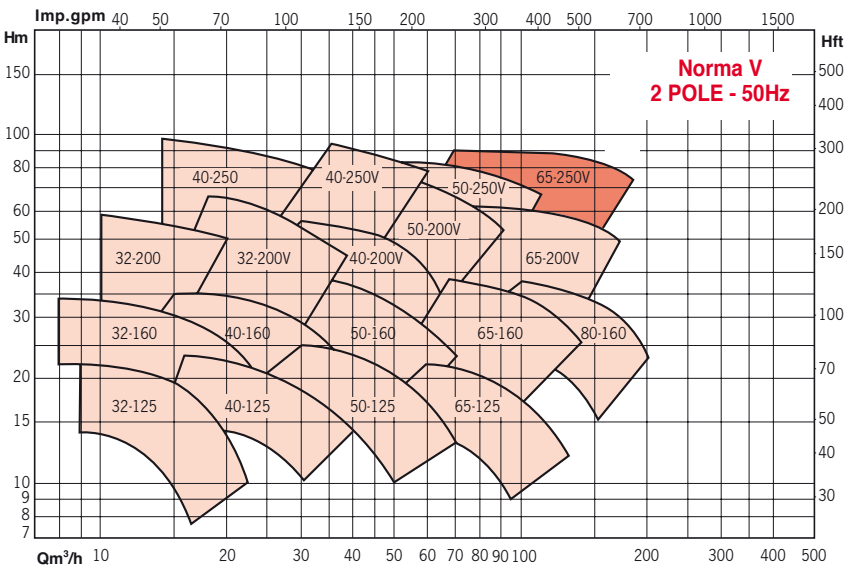

RECOMMENDED ACCESSORIES

- Motor protection circuit breaker
- Shut-off valves
- Pressure gauge
- Strainer (available as option)

NORMA V

HYDRAULIC PERFORMANCE NORMA V - 4-POLE - 1,450 RPM

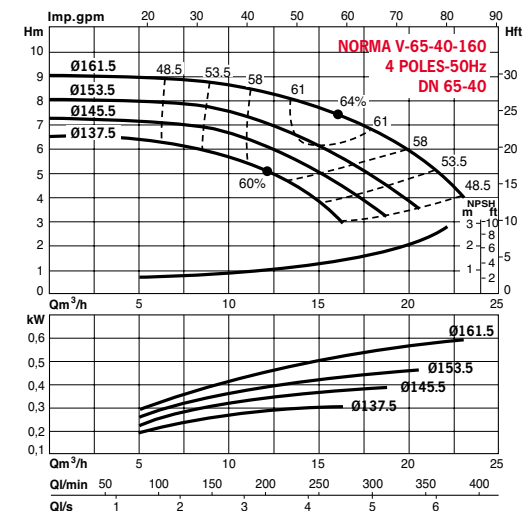
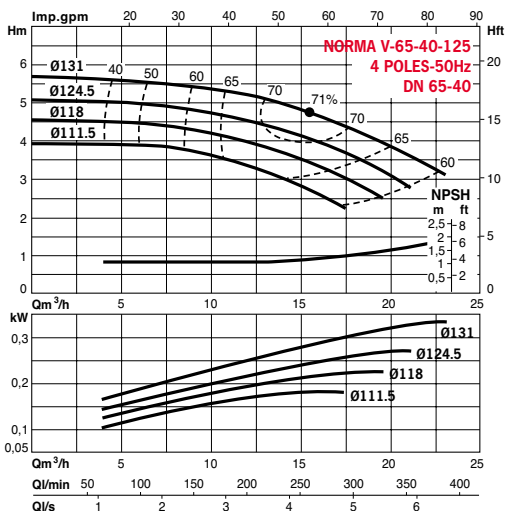
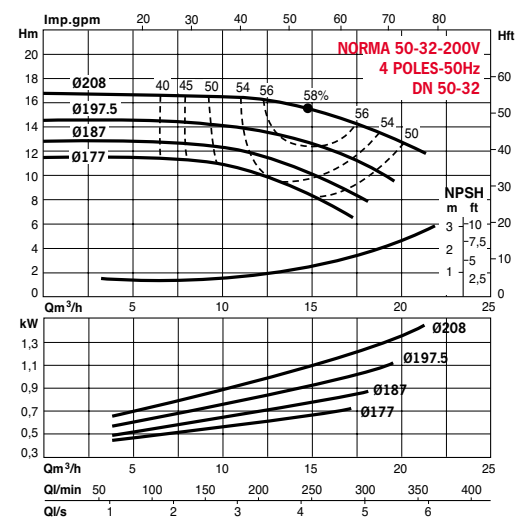
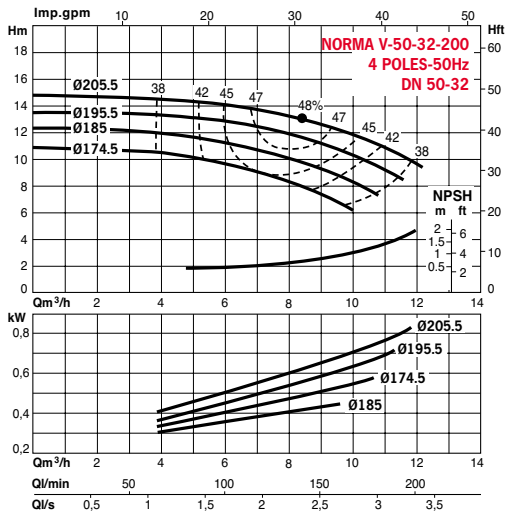
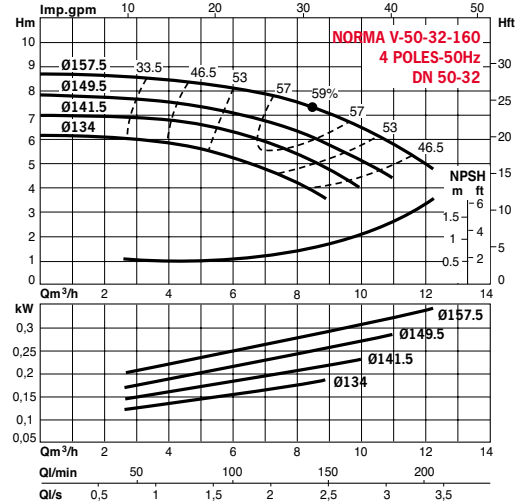
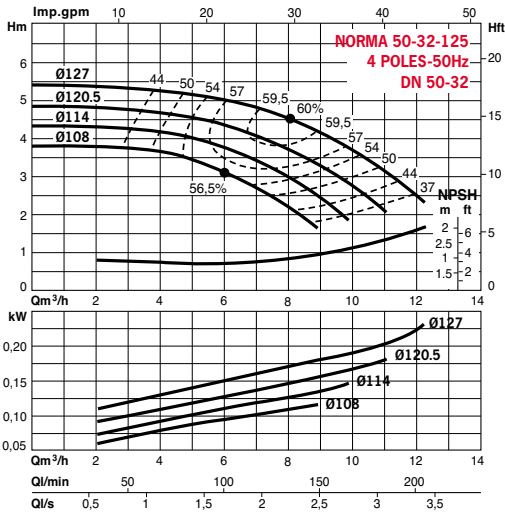

NORMA V

HYDRAULIC PERFORMANCE NORMA V - 4-POLE - 1,450 RPM

TEST CONDITIONS

- Motor : 4-pole
- Frequency : 50 Hz
- Fluid used : Water
- Fluid density : 1
- Fluid viscosity : 1 mm²/s
- Fluid temperature : 20°C

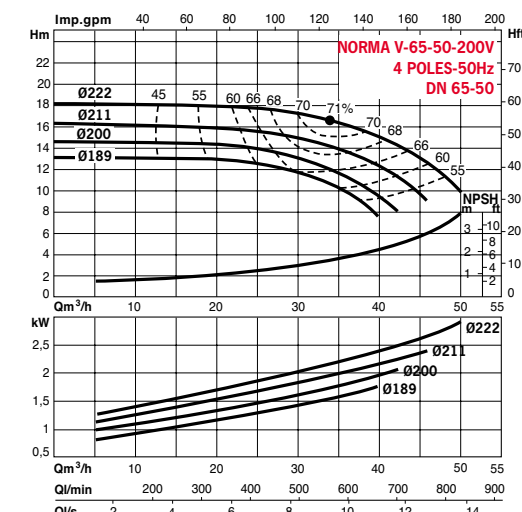
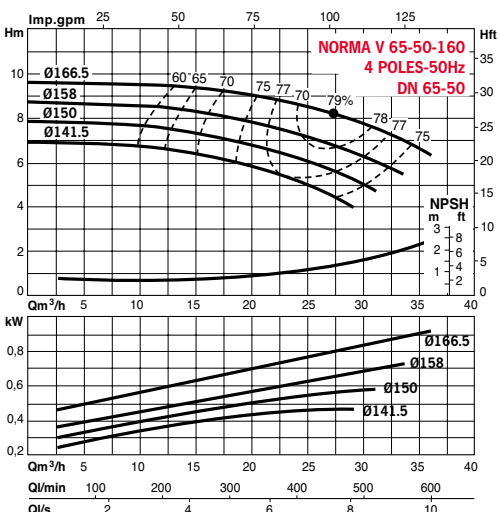
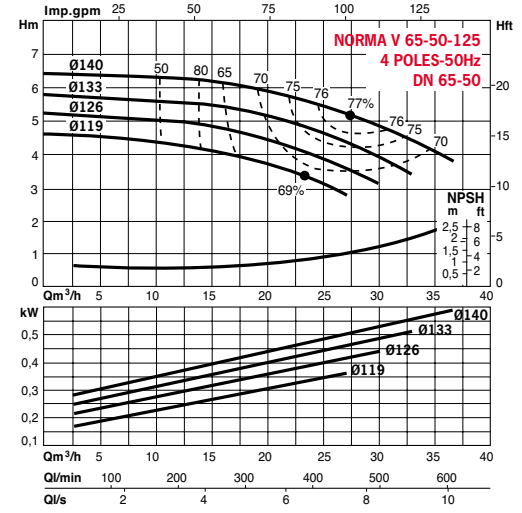
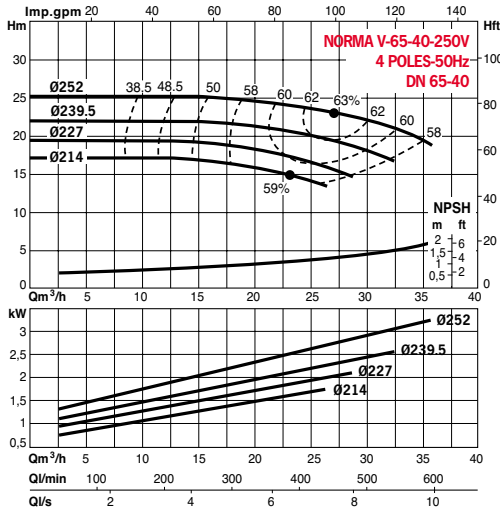
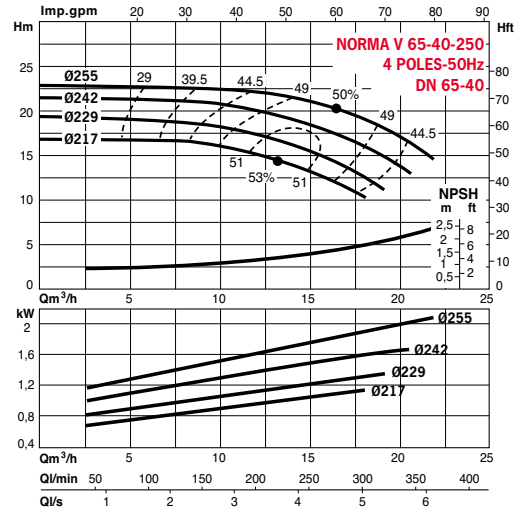
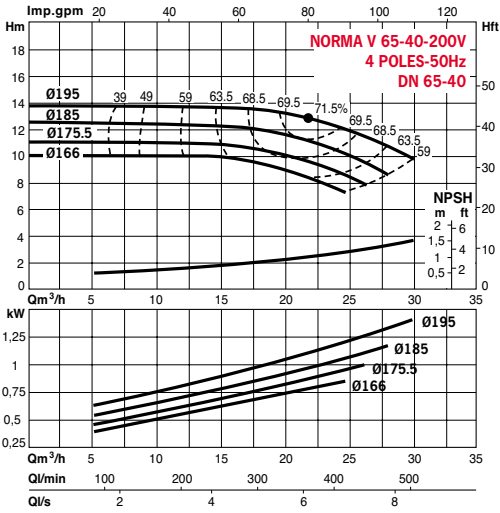

NORMA V

HYDRAULIC PERFORMANCE NORMA V - 4-POLE - 1,450 RPM

TEST CONDITIONS

- Motor : 4-pole
- Frequency: 50 Hz
- Fluid used: Water
- Fluid density: 1
- Fluid viscosity: 1 mm²/s
- Fluid temperature: 20°C

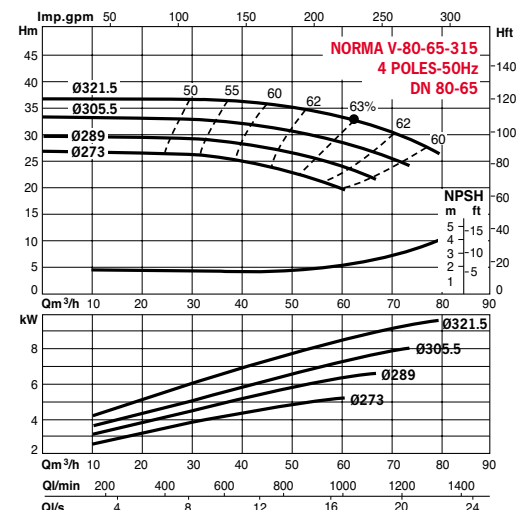
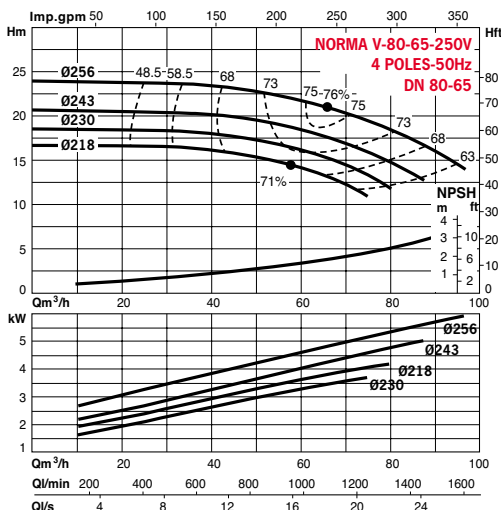
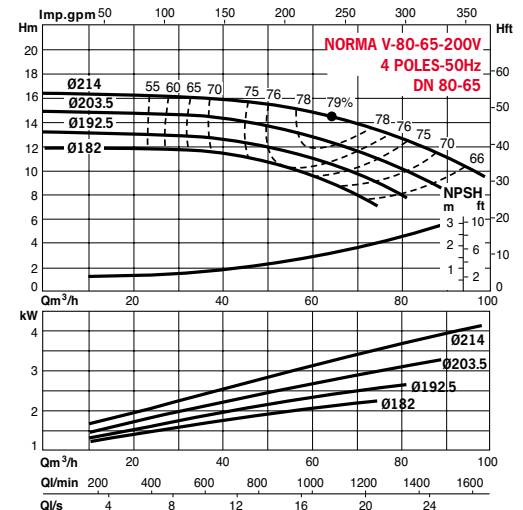
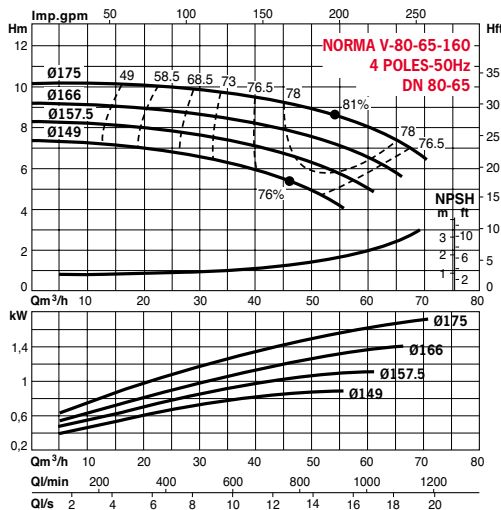
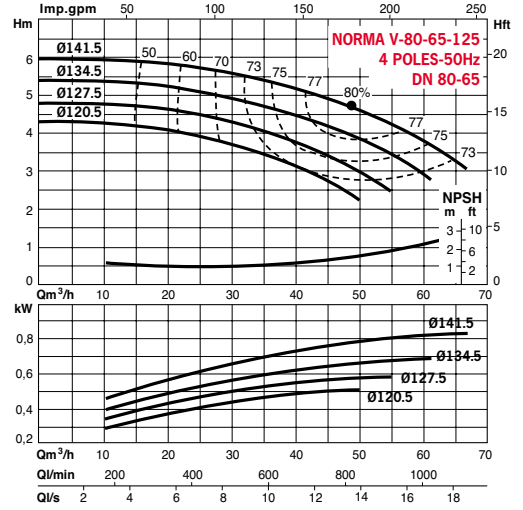
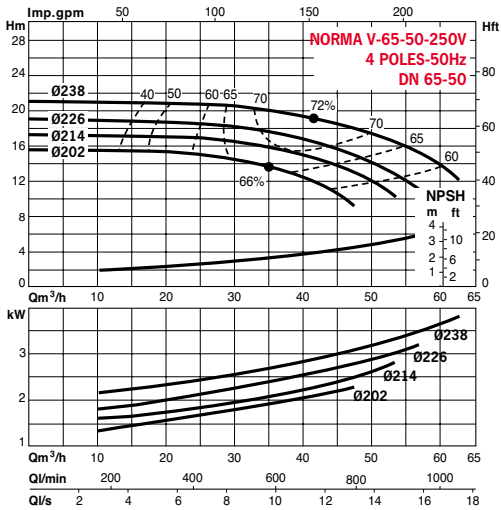

NORMA V

HYDRAULIC PERFORMANCE NORMA V - 4-POLE - 1,450 RPM

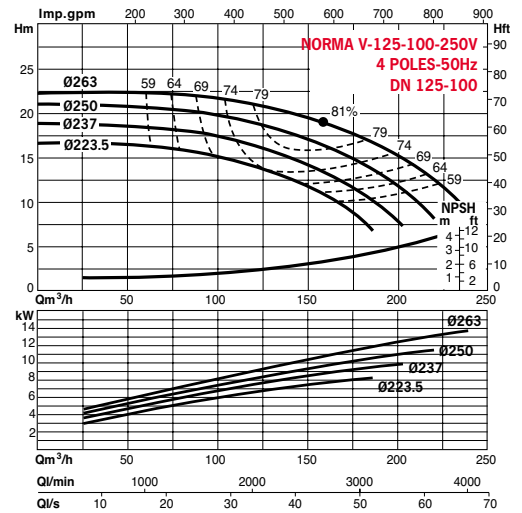
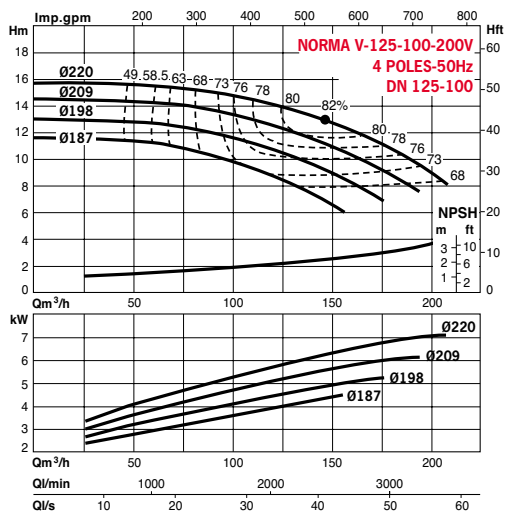
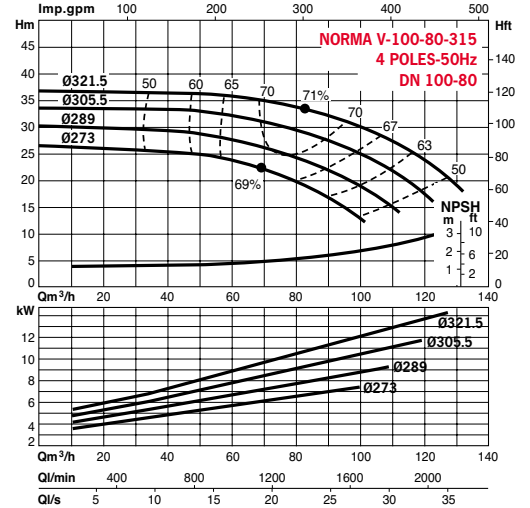
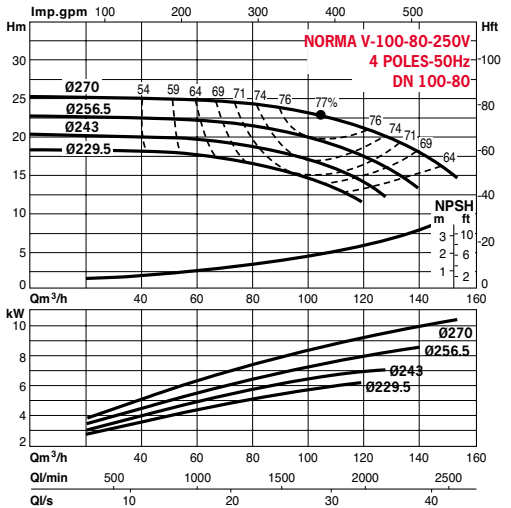
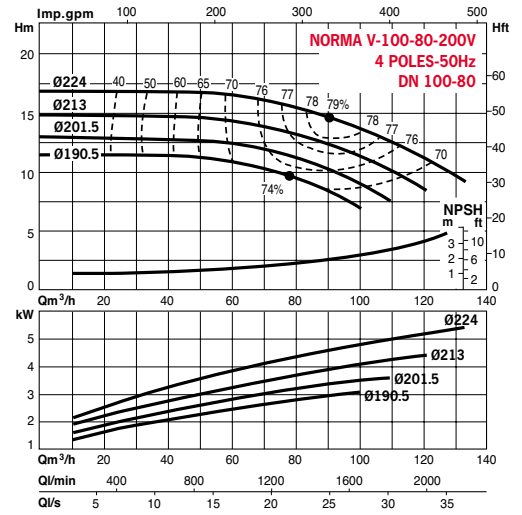
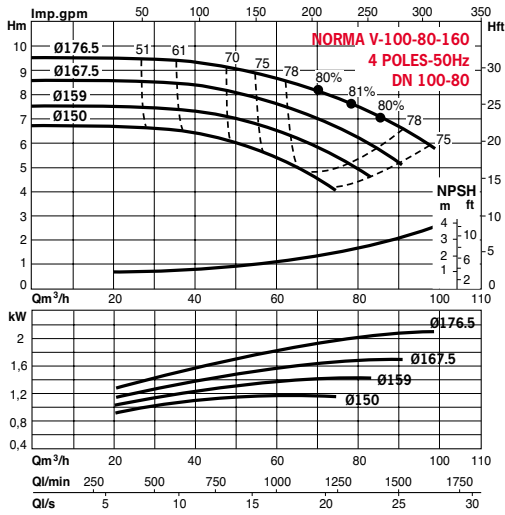

NORMA V

HYDRAULIC PERFORMANCE NORMA V - 4-POLE - 1,450 RPM

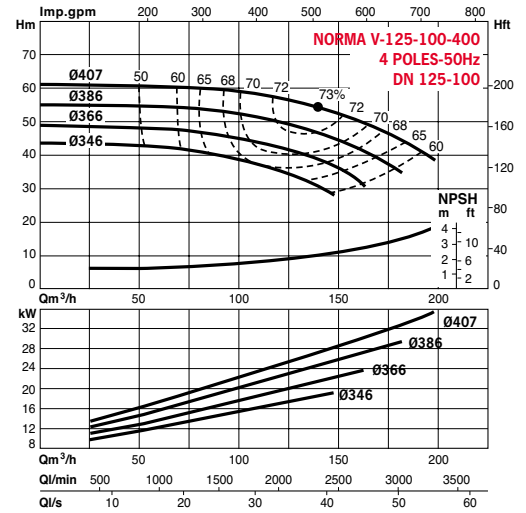
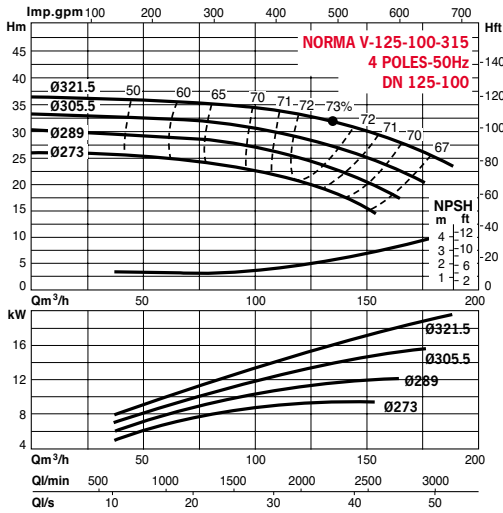

NORMA V

HYDRAULIC PERFORMANCE NORMA V - 2-POLE - 2,900 RPM

TEST CONDITIONS

- Motor : 2-pole
- Frequency : 50 Hz
- Fluid used : Water
- Fluid density : 1
- Fluid viscosity : 1 mm²/s
- Fluid temperature : 20°C

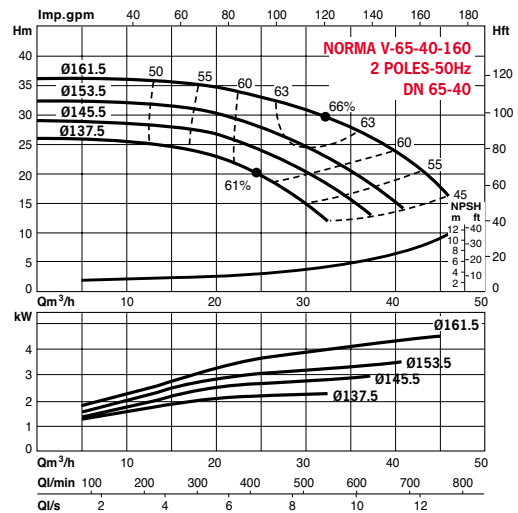
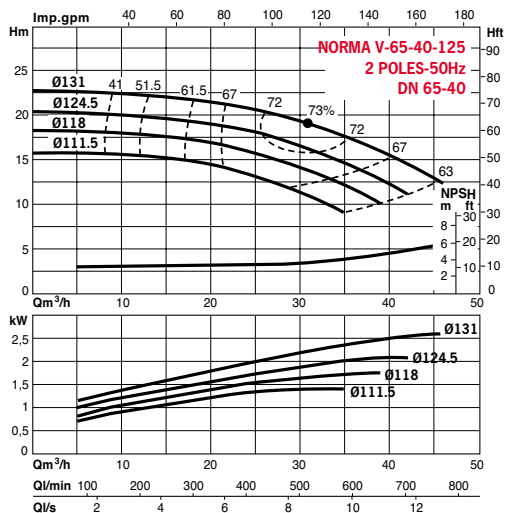
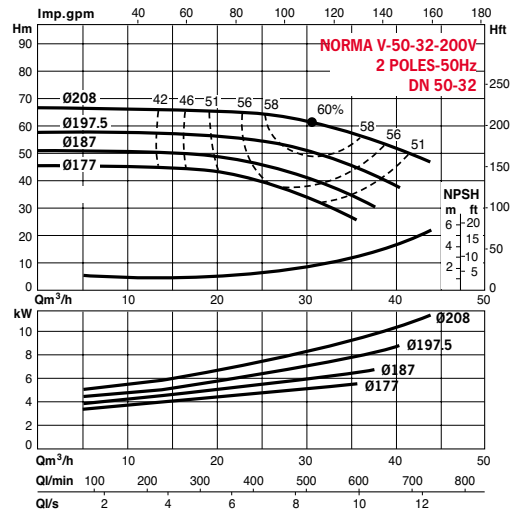
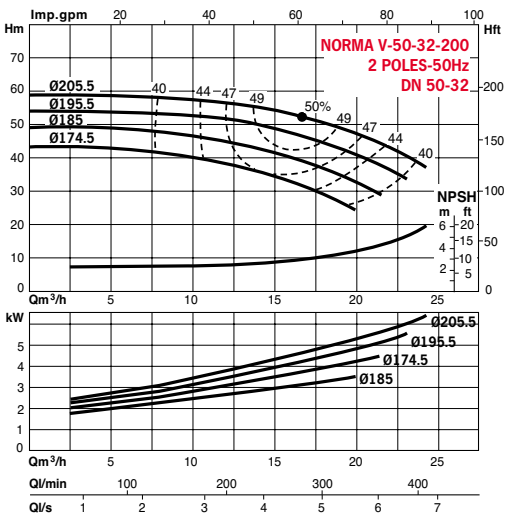
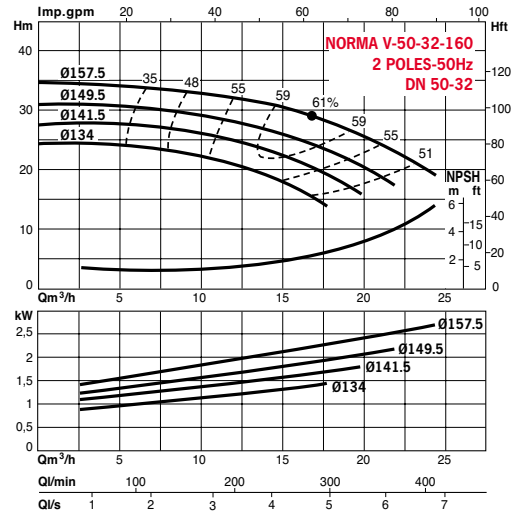
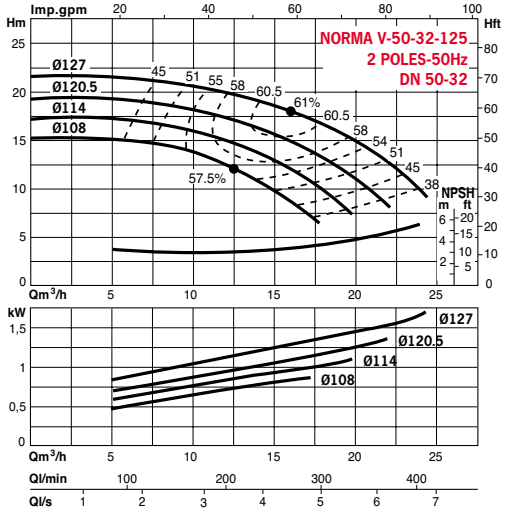

NORMA V

HYDRAULIC PERFORMANCE NORMA V - 2-POLE - 2,900 RPM

TEST CONDITIONS

- Motor : 2-pole
- Frequency : 50 Hz
- Fluid used : Water
- Fluid density : 1 mm³/s
- Fluid viscosity : 1 mm²/s
- Fluid temperature : 20°C

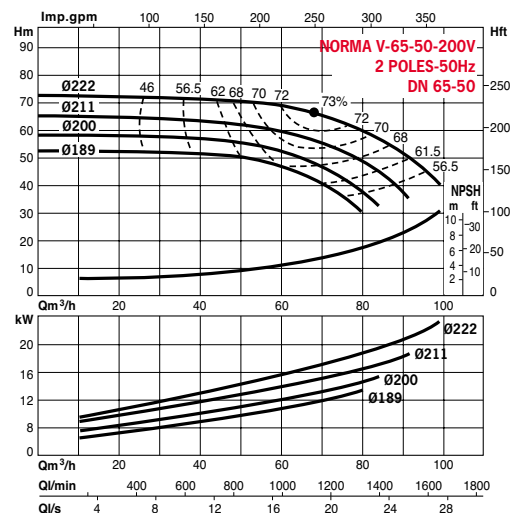
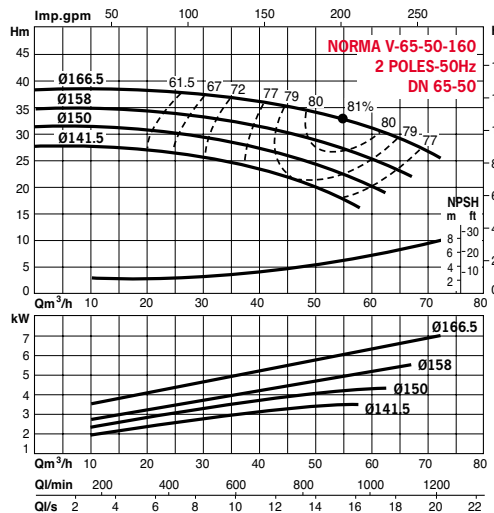
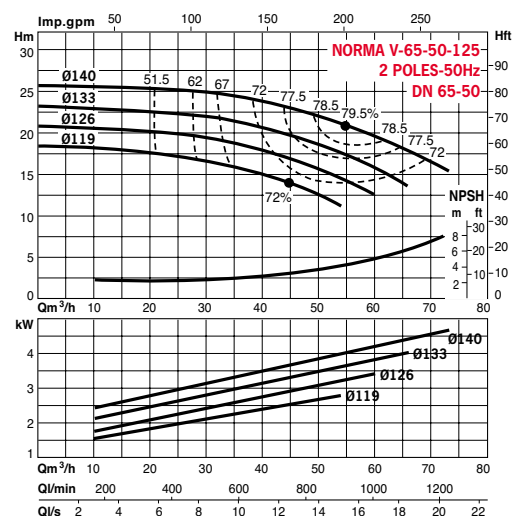
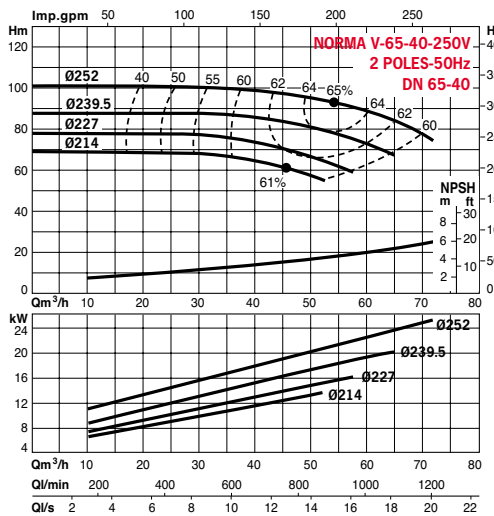
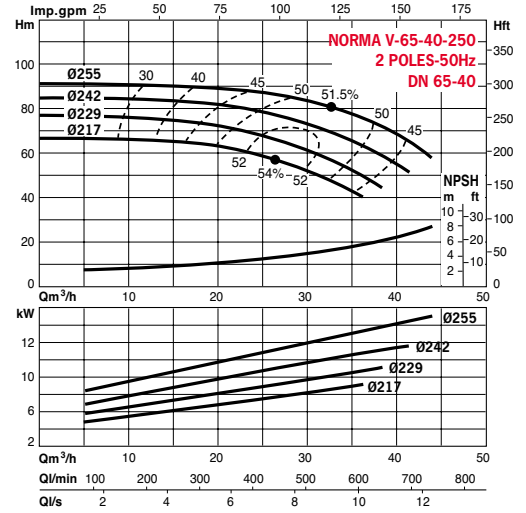
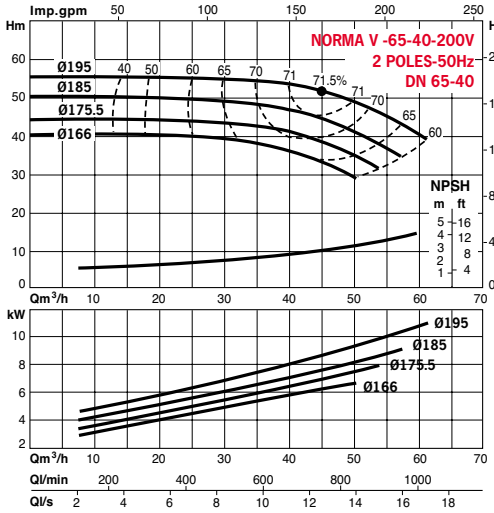

NORMA V

HYDRAULIC PERFORMANCE NORMA V - 2-POLE - 2,900 RPM

TEST CONDITIONS

- Motor : 2-pole
- Frequency : 50 Hz
- Fluid used : Water
- Fluid density : 1
- Fluid viscosity : 1 mm²/s
- Fluid temperature : 20°C

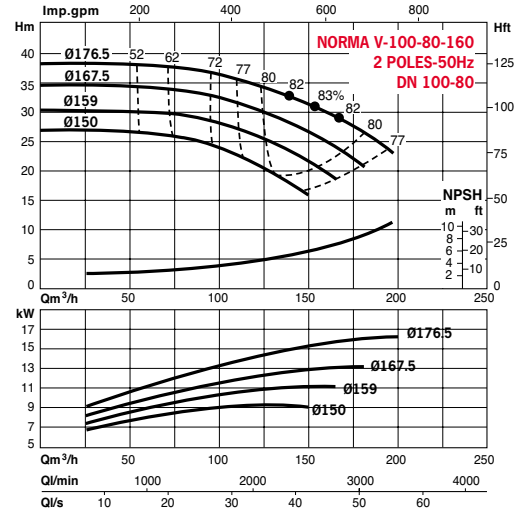
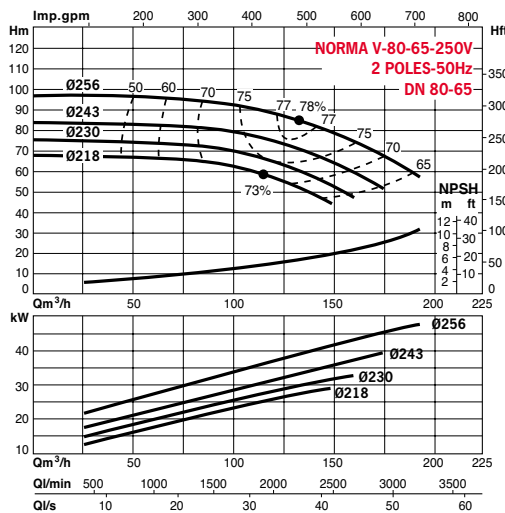
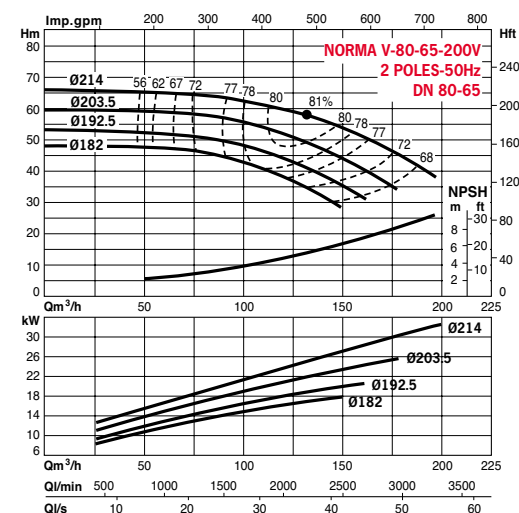
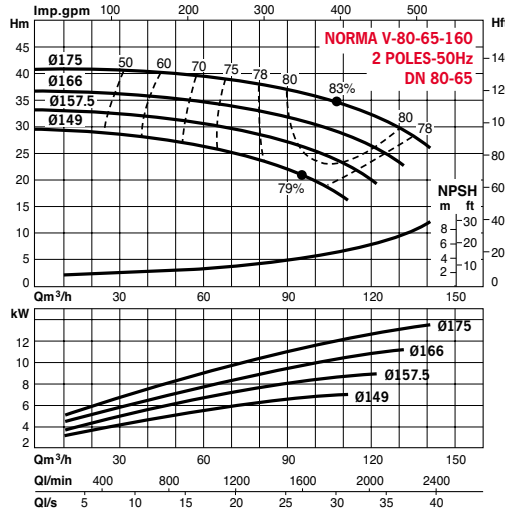
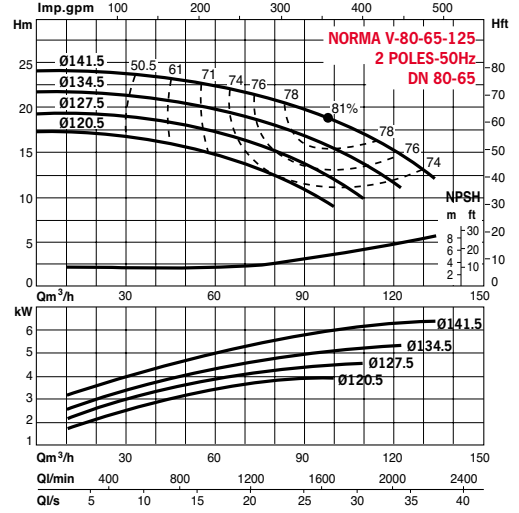
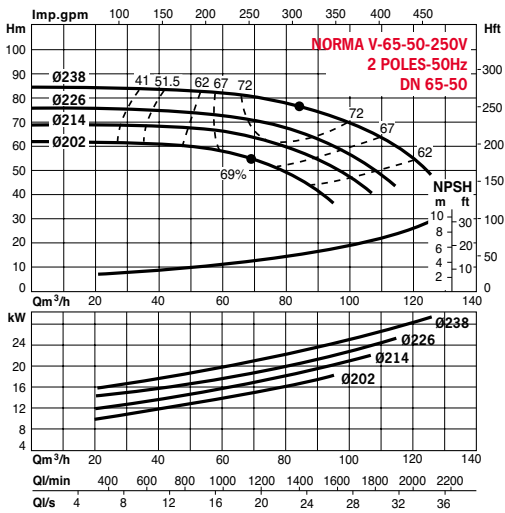

NORMA V

DETAIL SECTIONAL DRAWING - NORMA VCS

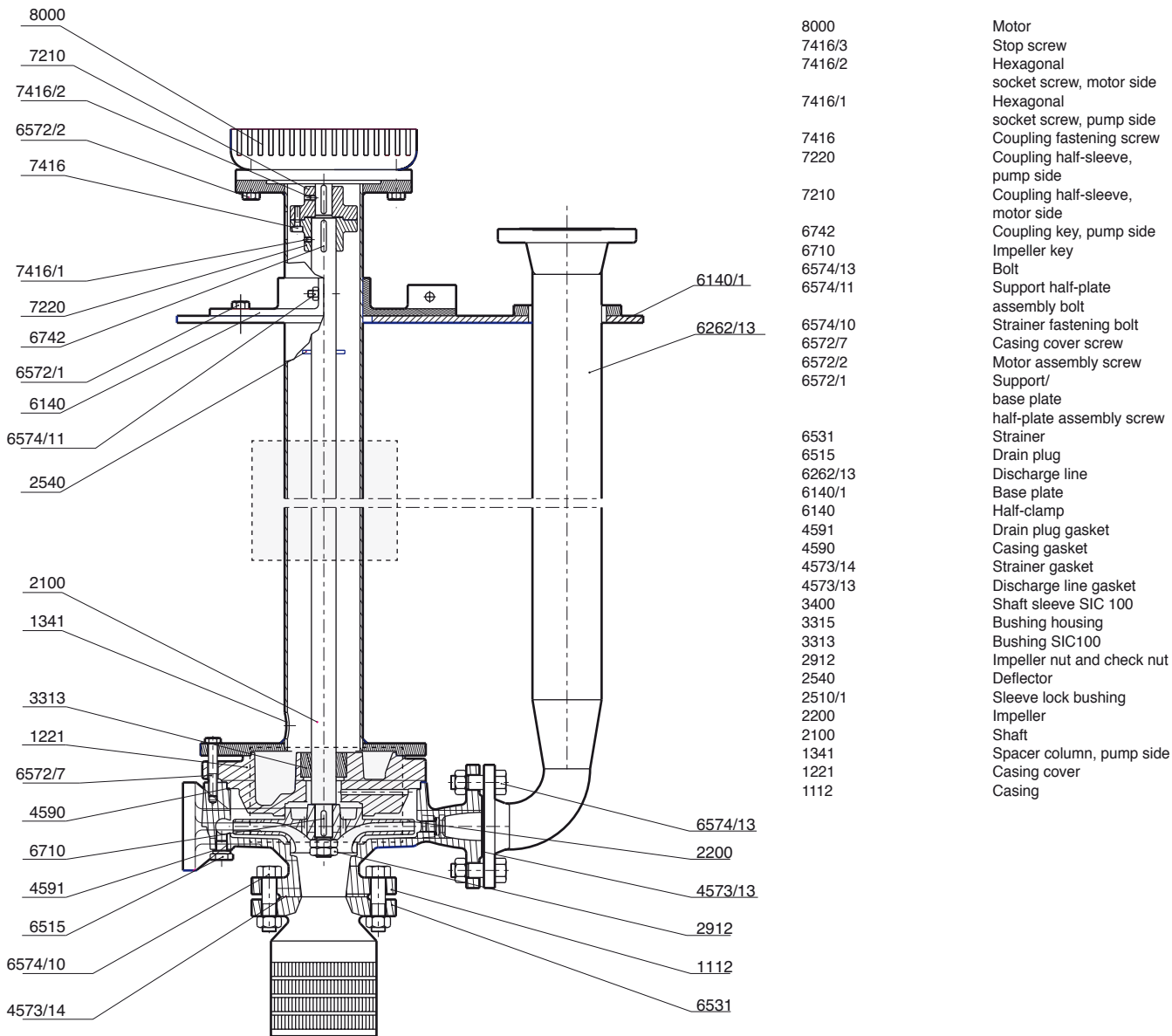

- 8000 Motor
- 7416/3 Stop screw
- 7416/2 Hexagonal socket screw, motor side
- 7416/1 Hexagonal socket screw, pump side
- 7416 Coupling fastening screw
- 7220 Coupling half-sleeve, pump side
- 7210 Coupling half-sleeve, motor side
- 6742 Coupling key, pump side
- 6710 Impeller key
- 6574/13 Bolt
- 6574/11 Support half-plate assembly bolt
- 6574/10 Strainer fastening bolt
- 6572/7 Casing cover screw
- 6572/2 Motor assembly screw
- 6572/1 Support/base plate half-plate assembly screw
- 6531 Strainer
- 6515 Drain plug
- 6262/13 Discharge line
- 6140/1 Base plate
- 6140 Half-clamp
- 4591 Drain plug gasket
- 4590 Casing gasket
- 4573/14 Strainer gasket
- 4573/13 Discharge line gasket
- 3400 Shaft sleeve SIC 100
- 3315 Bushing housing
- 3313 Bushing SIC100
- 2912 Impeller nut and check nut
- 2540 Deflector
- 2510/1 Sleeve lock bushing
- 2200 Impeller
- 2100 Shaft
- 1341 Spacer column, pump side
- 1221 Casing cover
- 1112 Casing

Intermediate bearing option

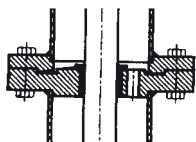

Silicium carbide bearing option

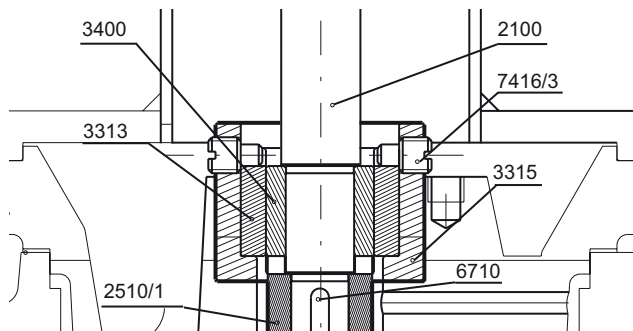

NORMA V

DETAIL SECTIONAL DRAWING - NORMA VEM

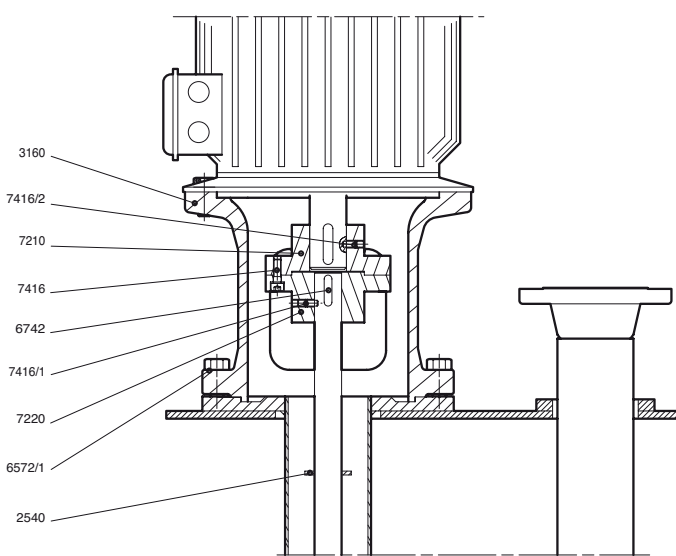

7416
7416/2
7416/1
7220
7210
6742
7416/1
7220
6572/1
2540

Coupling assembly screw
Hexagonal socket screw, motor side
Hexagonal socket screw, pump side
Coupling half-sleeve, pump side
Coupling half-sleeve, motor side
Coupling key, pump side
Lantern/spacer column assembly bolt
Lantern

DETAIL SECTIONAL DRAWING - NORMA VTM

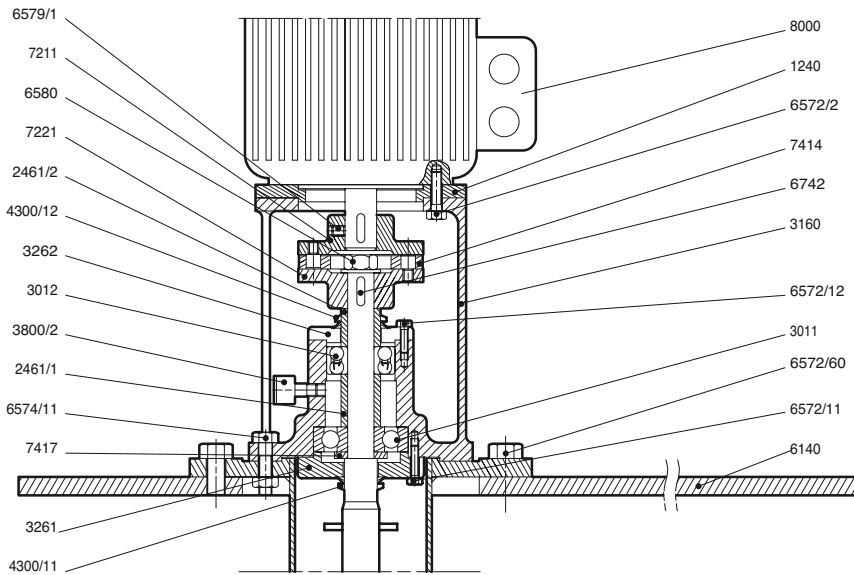

6579/1
7211
6580
7221
2461/2
4300/12
3262
3012
3800/2
2461/1
6574/11
7417
3261
4300/11

8000
7417
7414
7221
7211
6742
6580
6579/1
6574/11
6572/12
6572/11
6572/2
6140
4300/12
4300/11
3800/2
3262
3261
3160
3012
3011
2540
2461/2
2461/1
2100
1240

Motor
Thrust washer of lower bearing
Coupling flector
Coupling half-sleeve, pump side
Coupling half-sleeve, motor side
Coupling key, pump side
Coupling lock nut, pump side
Teat retaining screw, motor side
Base plate assembly bolt
Upper bearing cover assembly screw
Lower bearing cover assembly screw
Motor assembly screw
Sole plate
Upper cover gasket
Lower cover gasket
Ball bearing lubricator
Bearing upper cover
Bearing lower cover
Lantern
Upper bearing
Lower bearing
Deflector
Spacer
Bearing spacer
Shaft
Spacer flange for motor adaptation

NORMA V

LUBRICATION OPTION

• By external fluid

• By pumped fluid

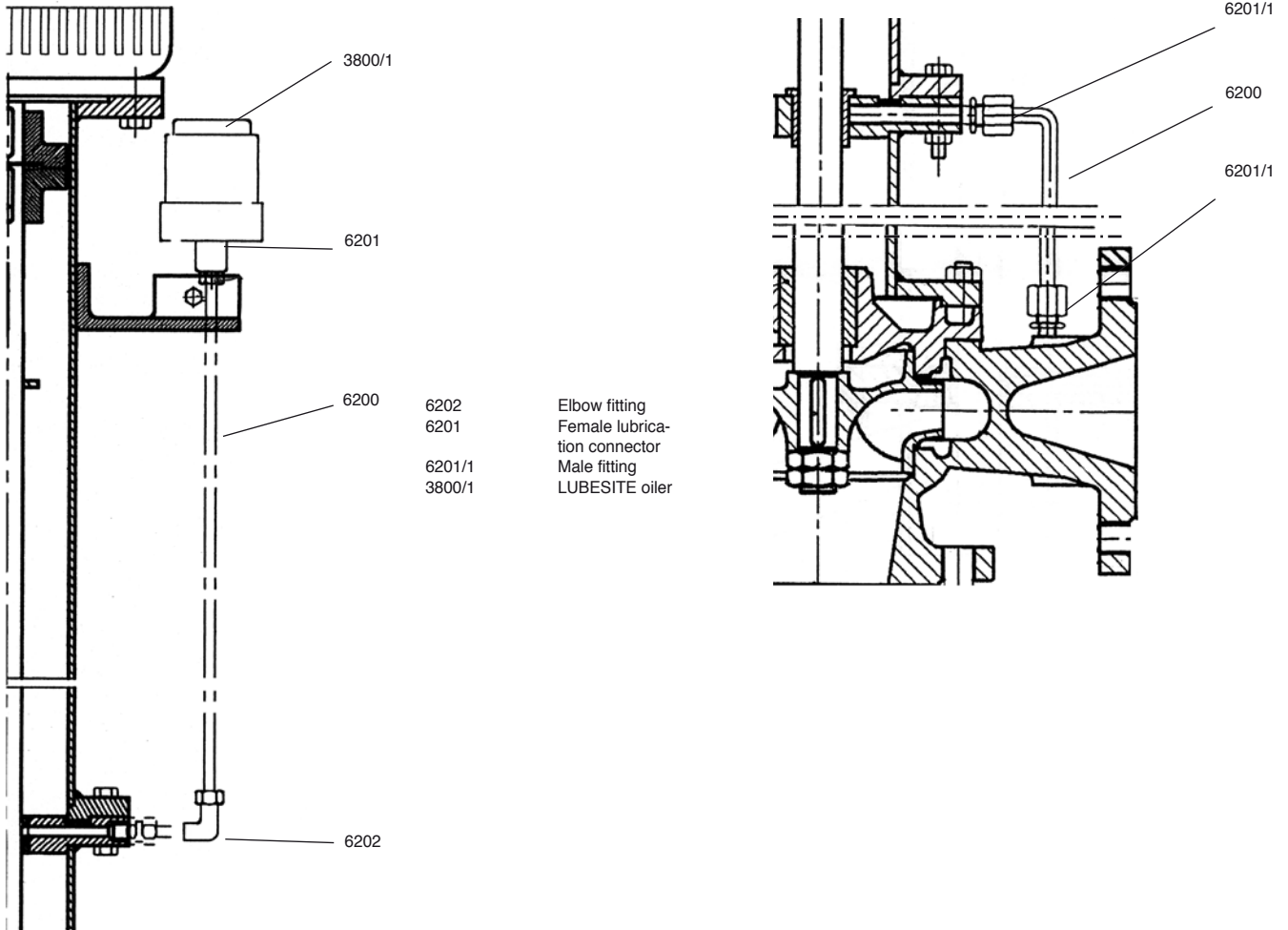

VCS - VEM - VTM CONSTRUCTION SELECTION DIAGRAM

Select VCS - VEM or VTM construction based on the height below the mounting plane (dimension "O" on installation drawings) and motor power (according to curves).

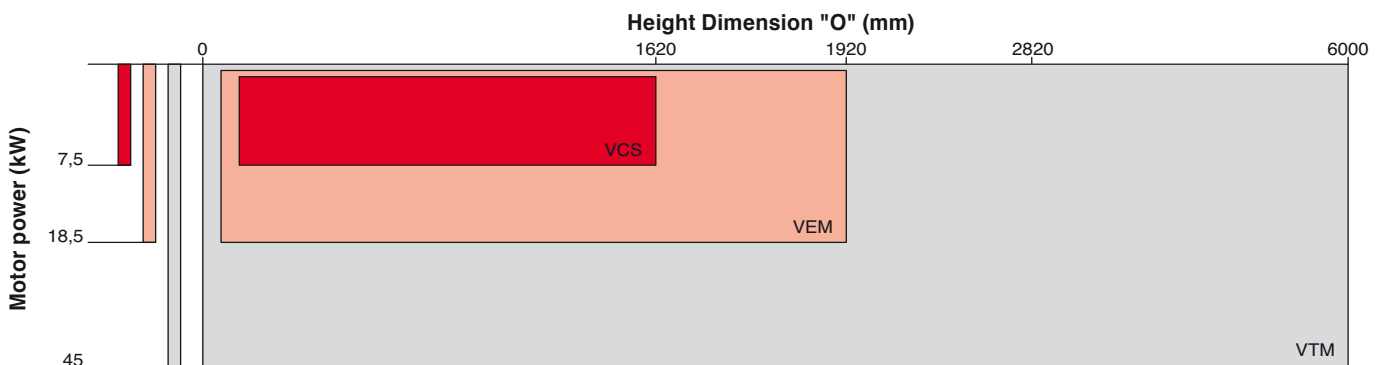

NORMA VCS

ELECTRICAL AND DIMENSIONAL CHARACTERISTICS - NORMA VCS

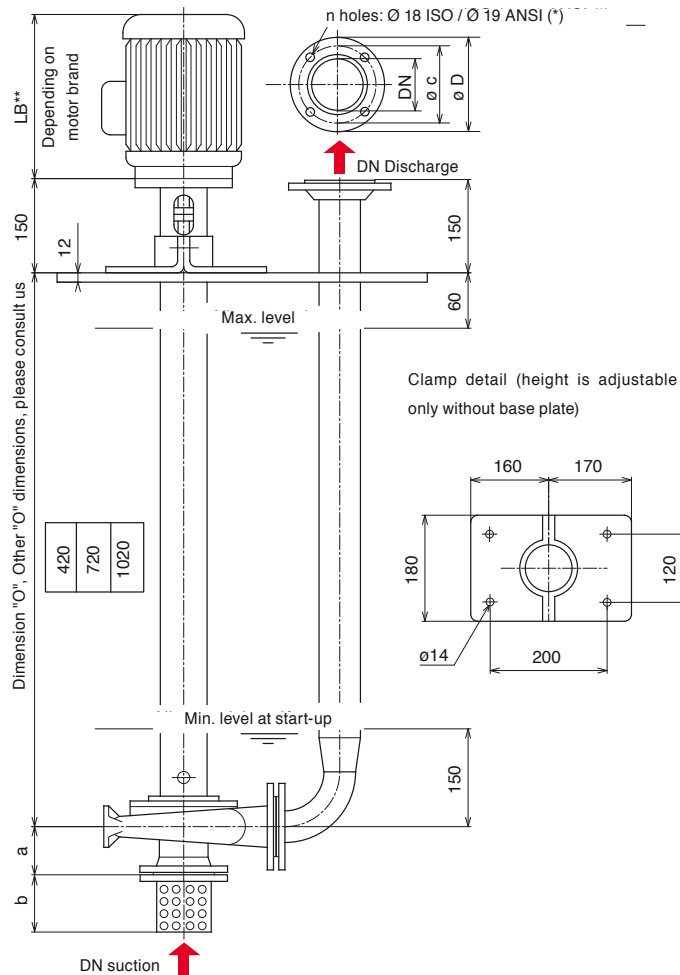

Detail of the pump foot print and the discharge flange
* opening in the tank for pump passage

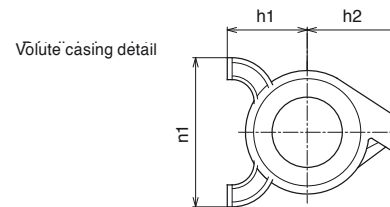
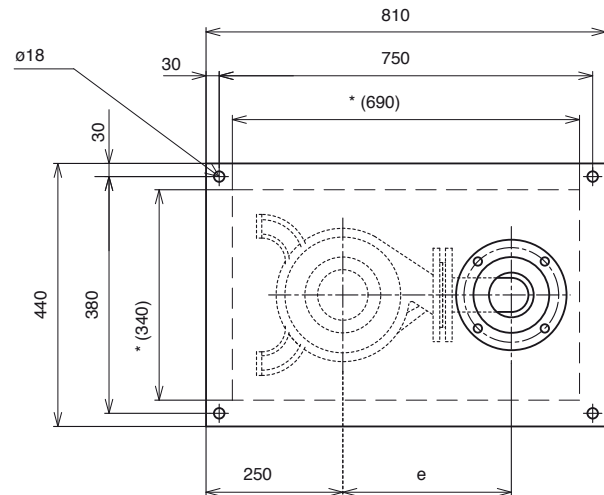

Pump type	Rotation speed		Discharge line					DN	e
	1450	2900	a	h1	h2	n1			
NORMA V 50-32-125	•	•	80	112	140	190	50	230	
NORMA V 50-32-160	•	•	80	132	160	240	50	250	
NORMA V 50-32-200	•	•	80	160	180	240	50	270	
NORMA V 50-32-200V	•	•	80	160	180	240	50	270	
NORMA V 65-40-125	•	•	80	112	140	210	65	242	
NORMA V 65-40-160	•	•	80	132	160	240	65	262	
NORMA V 65-40-200V	•	•	100	160	180	265	65	282	
NORMA V 65-40-250	•	—	100	180	225	320	65	327	
NORMA V 65-40-250V	•	—	100	180	225	320	65	327	
NORMA V 65-50-125	•	•	100	132	160	240	80	284	
NORMA V 65-50-160	•	•	100	160	180	265	80	304	
NORMA V 65-50-200V	•	—	100	160	200	265	80	324	
NORMA V 65-50-250V	•	—	100	180	225	320	80	349	
NORMA V 80-65-125	•	•	100	160	180	280	100	323	
NORMA V 80-65-200V	•	—	100	180	225	320	100	368	
NORMA V 100-80-160	•	—	125	180	225	320	125	393	

Motor power	(*) LB	
	1,450 rpm	2,900 rpm
0,75 kW	215	215
1,1 kW	238	238
1,5 kW	265	265
2,2 kW	290	265
3 kW	290	290
4 kW	290	290
5,5 kW	—	350
7,5 kW	—	350
9 kW	—	387

Strainer DN	b
50	127
65	149
80	179
100	215

Discharge flange ANSI 150			
DN	Øc	ØD	n
50	120,6	152	4
65	139,7	178	4
80	152,5	190	8
100	190,5	229	8
125	215,9	254	8

Discharge flange ISO PN 16			
DN	Øc	ØD	n
32	100	140	4
40	110	150	4
50	125	165	4
65	145	185	4
80	160	200	8
100	180	220	8

NORMA VEM

ELECTRICAL AND DIMENSIONAL CHARACTERISTICS - NORMA VEM

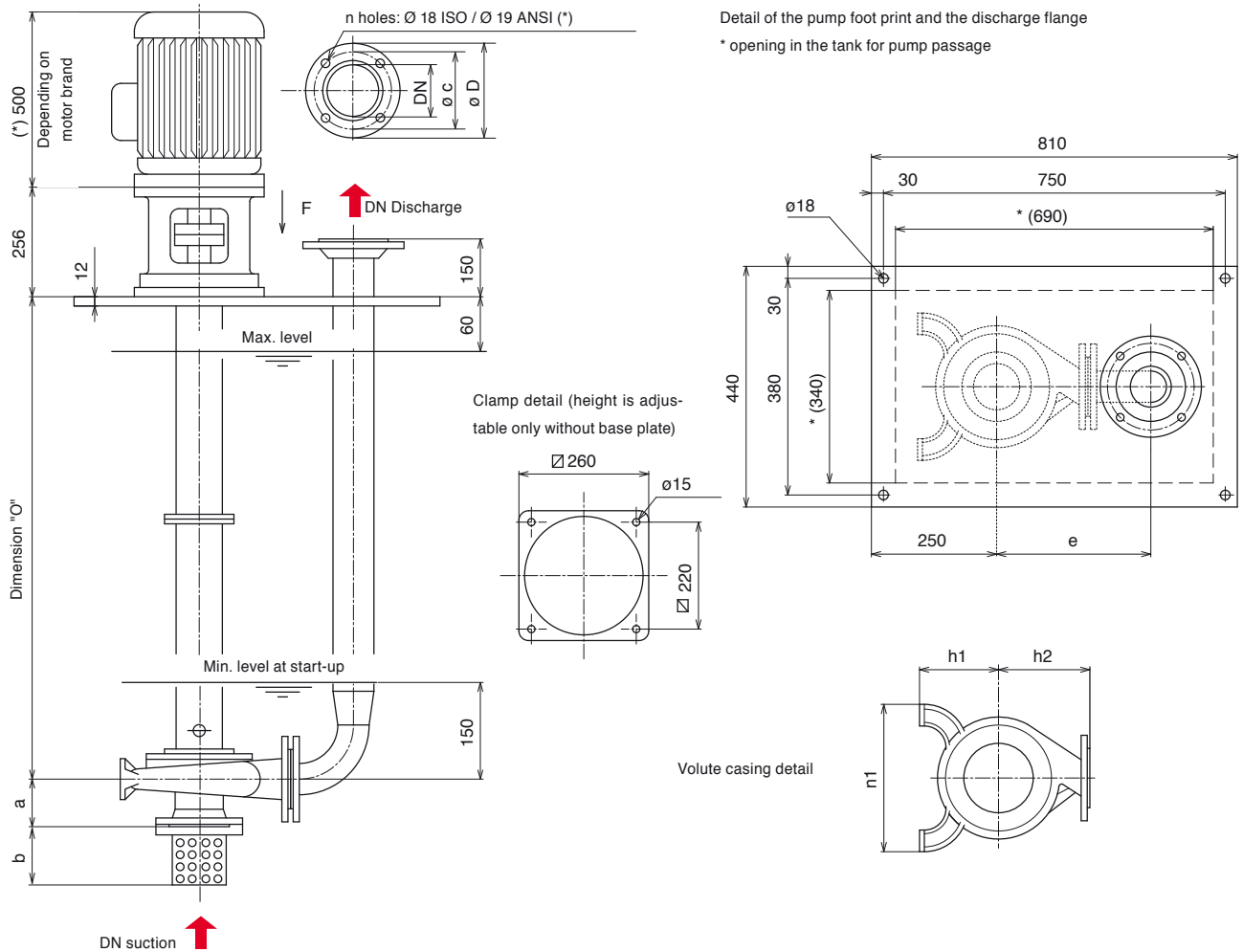

Pump type	Rotation speed	Discharge line					
		a	h1	h2	n1	DN	e
NORMA V 50-32-200V	2,900 rpm	80	160	180	240	50	270
NORMA V 65-40-200V	•	100	160	180	265	65	262
NORMA V 65-40-250	•	100	180	225	320	65	327
NORMA V 65-40-250V	•	100	180	225	320	65	327
NORMA V 65-50-200V	•	100	160	200	265	80	324
NORMA V 65-50-250V	•	100	180	225	320	80	349
NORMA V 80-65-160	•	100	160	200	280	100	343
NORMA V 80-65-200V	•	100	180	225	320	100	368
NORMA V 100-80-160	•	125	180	225	320	125	393

DN of the line adaptable according to the flow rate

Discharge flange ISO PN 16				Discharge flange ANSI 150			
DN	Øc	ØD	n	DN	Øc	ØD	n
32	100	140	4	50	120,6	152	4
40	110	150	4	65	139,7	178	4
50	125	165	4	80	152,4	190	4
65	145	185	4	100	190,5	229	8
80	160	200	8	125	215,9	254	8
100	180	220	8	(*) seul DN 125 ANSI 150 trous Ø22,2			

Dimension "O"	420	720	1020	1620	1920
Nbr of intermediate bearings	0	0	0	1	1
Other "O" dimension, please consult us					

Motor power

11 kW

15 kW

18,5 kW

NORMA VTM

ELECTRICAL AND DIMENSIONAL CHARACTERISTICS - NORMA VTM

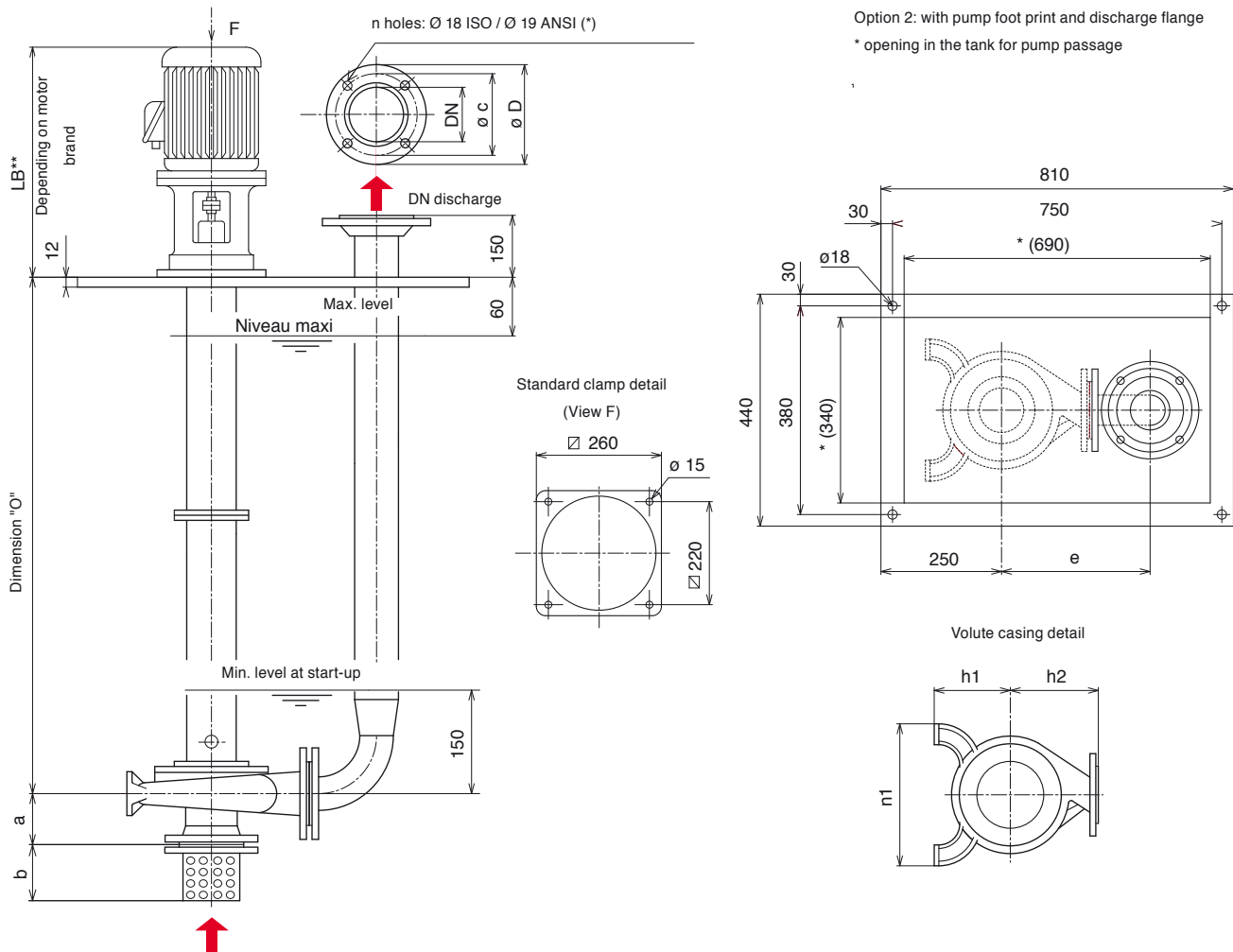

Pump type	Rotation speed		Discharge line					
	1,450 rpm	2,900 rpm	a	h1	h2	n1	DN	e
NORMA V 50-32-125	•	•	80	112	140	190	50	230
NORMA V 50-32-160	•	•	80	132	160	240	50	250
NORMA V 50-32-200	•	•	80	160	180	240	50	270
NORMA V 50-32-200V	•	•	80	160	180	240	50	270
NORMA V 65-40-125	•	•	80	112	140	210	65	242
NORMA V 65-40-160	•	•	80	132	160	240	65	262
NORMA V 65-40-200V	•	•	100	160	180	265	65	282
NORMA V 65-40-250	•	—	100	180	225	320	65	327
NORMA V 65-40-250V	•	—	100	180	225	320	65	327
NORMA V 65-50-125	•	•	100	132	160	240	80	284
NORMA V 65-50-160	•	•	100	160	180	265	80	304
NORMA V 65-50-200V	•	—	100	160	200	265	80	324
NORMA V 65-50-250V	•	—	100	180	225	320	80	349
NORMA V 80-65-125	•	•	100	160	180	280	100	323
NORMA V 80-65-160	•	•	100	180	200	280	100	343
NORMA V 80-65-200V	•	—	100	180	225	320	100	368
NORMA V100-80-160	•	—	125	180	225	320	125	393

DN of the discharge line adaptable according to the flow rate

Motor power	(*) LB	
	1,450 rpm	2,900 rpm
1,1 kW	438	—
1,5 kW	495	—
2,2 kW	490	465
3 kW	490	490
4 kW	490	490
5,5 kW	—	550
7,5 kW	—	550

DN	b
50	127
65	149
80	179
100	215

Discharge flange ISO PN 16			
DN	Øc	ØD	n
50	125	165	4
65	145	185	4
80	160	200	8
100	180	220	8
125	210	250	8

Discharge flange ANSI 150			
DN	Øc	ØD	n
50	120,6	152	4
65	139,7	178	4
80	152,4	190	4
100	190,5	229	8
125	215,9	254	8

(*) only DN 125 ANSI 150 Ø 22.2 holes

Dimensions "O"	1920	2220	2520	2820
Nbr of intermediate bearings	1	1	2	2

Other "O" dimension, please consult us