

Axially split volute casing pumps

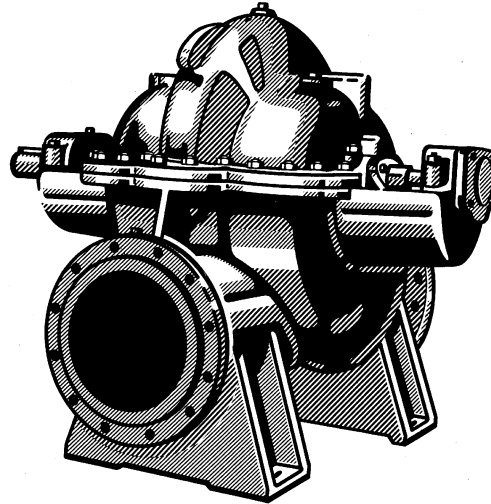

Applications

Waterworks, irrigation and drainage pumping stations, power stations, industrial water supply systems, fire fighting systems, marine applications as well as general applications in refineries.

Operating data

Pump sizes	DN 500	up to	800	
Capacities	Q	up to	3000	l/s
Total head	H	up to	150	m
Operating pressure	p	up to	25	bar
Operating temperature	t	up to	+ 105	°C

Design

Horizontal single stage axially split volute casing pump with double entry radial impeller

Drive shaft end of the pump can be fitted either on the left hand or right hand side

Flanges acc. to ISO, DIN, BS or ANSI

Designation

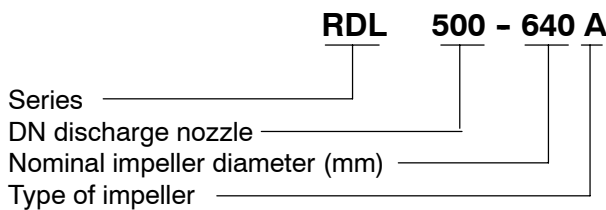

Bearings

Grease lubricated or optional oil lubricated, anti-friction bearings which can be re-lubricated

Shaft seal

Stuffing box packing or mechanical seal

Materials

	ASTM	similar to DIN
Volute casing upper part	A48 class 35	GG-25
	A536 class 604018	GGG-40
Volute casing lower part	A48 class 30	GG-20
	A536 class 604018	GGG-40
Shaft	SAE 1045	C45N
	AISI 420	1.4021
Impeller	B 584-90500	G-CuSn10
	A743 CA6NM	1.4313.95
	A743CF8M	1.4408
Shaft protecting sleeve	AISI 420	1.4021
Casing wear ring	B584-90500	G-CuSn10
	A743CA6NM	1.4313.95
Impeller wear ring	B584-90500	G-CuSn10
	A743CA6NM	1.4313.95

Table of content

Selection chart 50 Hz	page 3
Selection chart 60 Hz	page 4
Scope of supply Guarantee, testing and quality control Order data	page 5
Types of installation Direction of rotation and flow direction	page 6
Material combinations	page 7
Casing test pressure, flange ratings, shaft details	page 8
Technical data	page 9
Forces and moments Speeds Vibrations	page 10
Coating	page 11
Sectional drawing	page 12 + 13
Shaft seal	page 14 + 15
Dimension table for type of installation 2E	page 16 + 17
Dimension table for type of installation 4E	page 18 + 19
Spare parts	page 20 + 21
Accessories	page 22



Selection chart 50 Hz

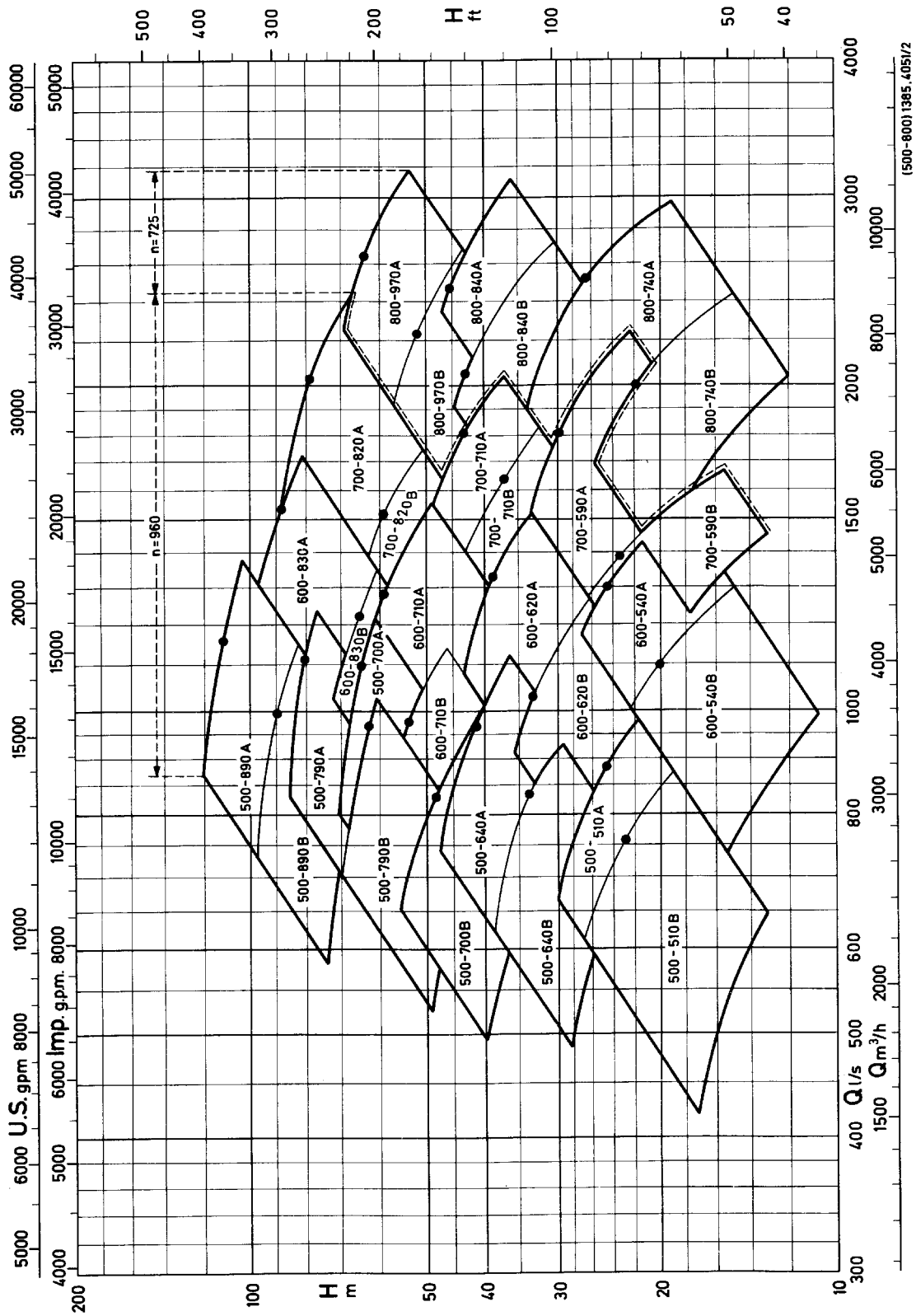



Selection chart 60 Hz

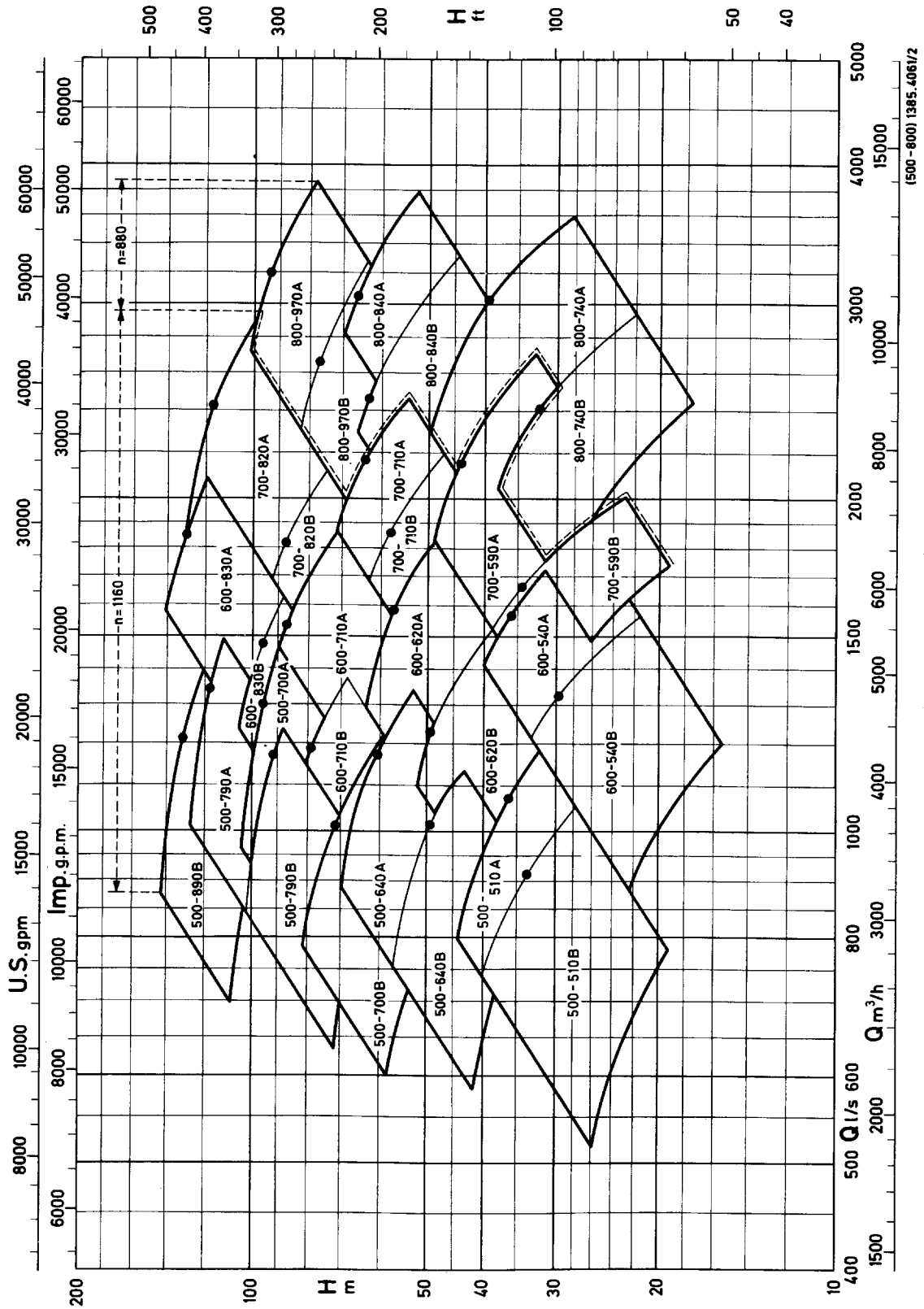

Scope of supply

Pump with bare shaft end, horizontal design, with primer coating, soft packed stuffing box or mechanical seal.

Extra charges for:

- oil lubricated antifriction bearings,
- potable water quality coating / top coat
- horizontal base frame for pump and motor,
- motor mounting,
- material tests

Available accessories:
(see page 21 for details)

- coupling and coupling guard,
- vibration sensor SPM-Nippel,
- set pressure gauges,
- cyclone separator with piping,
- venting valve,
- temperature sensor for antifriction bearing (PT 100)
- signal transmitter for PT 100
- assembly device / lifting device

Guarantee, testing and quality control

Every pump undergoes a functional test and the operating data is guaranteed **without** acceptance test.

Acceptance tests can be performed in accordance with ISO 2548 C, DIN 1944/III or other comparable international testing standards.

The quality of the RDL products is ensured by a tested and certified quality assurance system according to DIN ISO 9001 / EN 29001.

Order data

- pump :

- description of the pump according to "Designation"- capacity Q
- total head H (H_{geo} and plant losses)
- material combination
- flange design
- shaft seal as soft packed stuffing box or mechanical seal
- grease or oil lubricated bearings
- liquid handled and liquid temperature
- direction of rotation / arrangement of the motor
- accessories required
- number and language of operating manual

- motor :

(choice by KSB)

- type of construction
- protection
- voltage, frequency, method of starting
- ambient temperature
- insulation class
- accessories required

- motor :

(motor provided by the client)

binding motor dimension table and data sheet with specification of the effective speed to be given with the order

Types of installation

2E Pump and driver separate on foundation rails

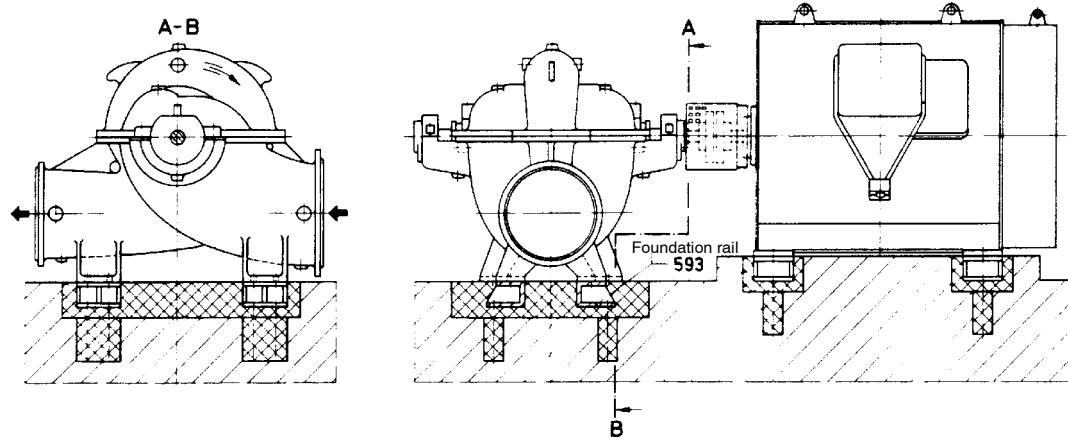

4E Pump and driver on separate baseframe

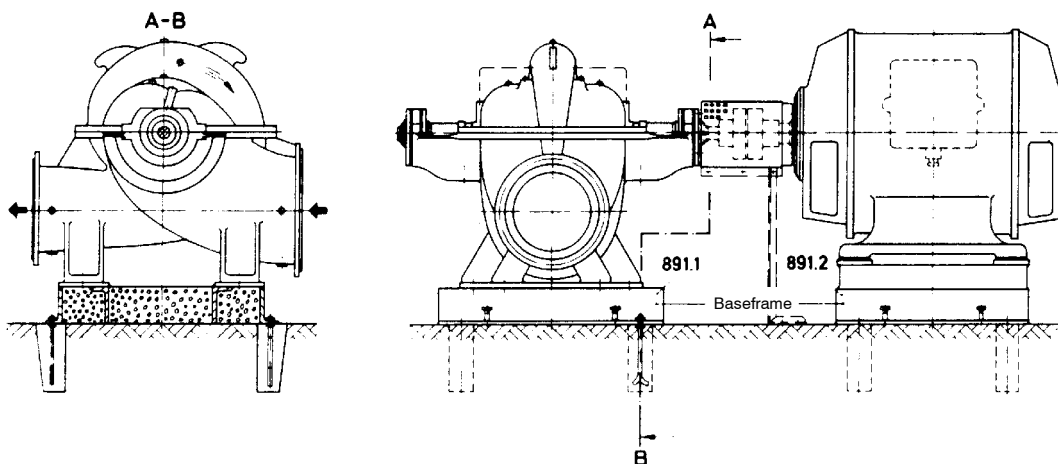

Direction of rotation and flow direction

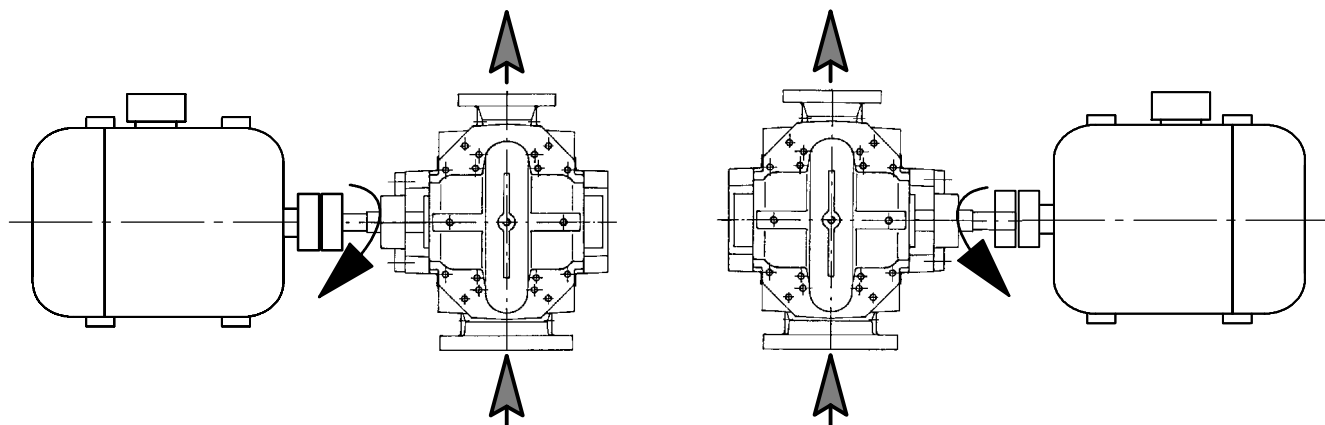

**Direction of rotation,
clockwise,
viewed from the drive end**

**Direction of rotation,
anticlockwise,
viewed from the drive end**

Material combinations

Part no.	Designation	ASTM - Materials / Similar to DIN					
		01	11	02	21	03	31
105.2	Volute casing, upper part	A 48 class 35 GG-25	A 536 class 604018 GGG-40	A 48 class 35 GG-25	A 536 class 604018 GGG-40	A 48 class 35 GG-25	A 536 class 604018 GGG-40
105.1	Volute casing, lower part	A 48 class 30 GG-20	A 536 class 604018 GGG-40	A 48 class 30 GG-20	A 536 class 604018 GGG-40	A 48 class 30 GG-20	A 536 class 604018 GGG-40
211	Shaft	SAE 1045 or AISI 420 C 45 N or 1.4021					
234	Impeller	B 584-90500 G-CuSn10		A 743 CA 6 NM 1.4313.95		A 743 CF 8 M 1.4408	
330	Bearing bracket	A 48 class 30 GG-20					
350	Bearing housing						
360	Bearing cover						
361	Bearing end plate						
452	Gland	A 48 class 30 GG-20	A 536 class 604018 GGG-40	A 48 class 30 GG-20	A 536 class 604018 GGG-40	A 48 class 30 GG-20	A 536 class 604018 GGG-40
457	Neck ring	B 584-90500 G-CuSn10					
458	Lantern ring	A 48 class 30 GG-20					
471	Seal cover (mech. seal)	A 48 class 30 GG-20					
502	Casing wear ring	B 584-90500 G-CuSn10					
503	Impeller wear ring						
524	Shaft protecting sleeve	AISI 420 1.4021					
525	Spacer sleeve	SAE 1020 8.8					
921	Shaft nut	AISI 316 A4					

Casing test pressures, flange ratings, shaft details

Pump sizes	Casing materials				Shaft material		Moments of inertia J kgm ² (without coupling)		Casing with double volute
	A48 class 30 (GG-20)	A536 class 604018 (GGG-40)	A48 class 30 (GG-20)	A536 class 604018 (GGG-40)	SAE 1045 (C45N)	AISI 420 (1.4021)	without-water	with water	
	Max. test pressure (bar)		Max. flange rating to DIN (bar)		permissible shaft loading P / n kW / 1/min				
500-510	11	18	10	16	0,582	0,945	3,45	4,875	-
500-640	15	25	10	25	1,19	1,93	7,5	10,35	-
500-700	18	28	16	25	1,61	2,61	10,075	13,95	x
500-790	25	35	25	25	2,11	3,43	13,375	20,825	x
500-890	28	36	25	25	3,45	5,6	23,15	31,25	x
600-540	11	20	10	16	0,582	0,945	5,15	7,275	-
600-620	13,5	22	10	16	0,836	1,36	8,5	11,6	-
600-710	18	27	16	25	1,61	2,61	13,7	18,2	-
600-830	18	27	16	25	2,11	3,43	22,325	30,25	x
700-590	10	18	10	16	1,19	1,93	10,05	12,875	-
700-710	12	20	10	16	1,61	2,61	17,5	23,5	-
700-820	18	24	16	16	1,76	4,48	31,5	35,25	x
800-740	10	16	10	16	1,61	2,61	25,5	31,75	-
800-840	11	17	10	16	2,11	3,43	37,25	46,25	-
800-970	13	20	10	16	3,45	5,6	61,75	72,25	-

Fig. 5

Flanges

- When selecting casing flanges to DIN take the following into consideration:
Nominal pressure of flanges \geq max. operating pressure. Minimum possible nominal pressure is 10 bar (PN 10), for max. nominal pressure see Fig. 5.
- If the suction and discharge flanges have different ratings then the difference must not exceed 1 rating stage (e.G. suction nozzle PN 16 and discharge nozzle PN 25).

Standard test pressure

1,2 · (Shut off head + suction pressure) or
1,5 · (Head at duty point + suction pressure)
The higher value to be used

Technical data

Impeller dimensions, Shaft diameter, stuffing box packing

Impeller outlet width Pump sizes	Impeller dimensions [mm]				Shaft diameter d_w [mm]			Stuffing box [mm]	
	A	B	A	B	in stuffing box housing	in mechanical seal (without shaft sleeve)	at coupling	Box dimensions D/d/l 	Packing ring section 5 rings
	Impeller rating b_2		Max. impeller-						
500-510	136	105	500/530	515/505	110	90	75	150/110/150	20x20
500-640	100	108	640	580	130	110	95	170/130/150	20x20
500-170	116	100	708	660	140	130	105	180/140/150	20x20
500-790	100	104	790	710	150	140	115	200/150/180	25x25
500-890	90	88	920	840	180	160	135	230/180/180	25x25
600-540	153	143	570	531/516	110	90	75	150/110/150	20x20
600-620	146	138	620	578/564	120	100	85	160/120/150	20x20
600-710	130	120	715	690	140	130	105	180/140/150	20x20
600-830	115	103	870	770	150	140	115	200/150/180	25x25
700-590	131	148	565	586/555	130	110	95	170/130/150	20x20
700-710	165	157	706/694	648/632	150	140	105	200/150/180	25x25
700-820	134	128	835	735	160	140	125	210/160/180	25x25
800-740	210	190	790/770	720/700	160	150	105	210/160/180	25x25
800-840	206	193	885	840	160	150	115	210/160/180	25x25
800-970	174	160	980	910	180	170	135	230/180/180	25x25

Fig. 4

Forces and moments

The forces and moments specified are mean values for simultaneous loading in 3 planes. Please contact the manufacturer if the forces and moments in one particular direction exceed the stipulated values. The figures in the table do not apply to reaction forces of unbraced expansion joints.

Material: A48 class 30
GG-20

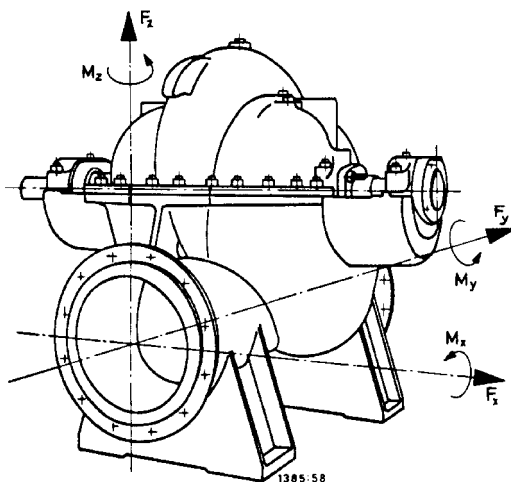

Pump sizes	Nozzle in N			Moments in Nm		
	Fx	Fy	Fz	Mx	My	Mz
500-510	6000	6000	6000	4000	4000	4000
500-640						
500-700						
500-790						
500-890						
600-540	8000	8000	8000	5000	5000	5000
600-620						
600-710	10000	10000	10000	8000	8000	8000
600-830						
700-590						
700-710						
700-820	11000	11000	11000	9000	9000	9000
800-740						
800-840	12000	12000	12000	9000	9000	9000
800-970						

Speeds

For higher speeds consult KSB also stipulating the pump operating range as per selection chart.

Vibrations

Vibration values of the pump according to VDI-Rules 2056, Group G, "good" up to "acceptable", ($V_{eff} < 4,5$ mm/s), in the operating range from 0,8 up to $1,2 \times Q_{Opt}$.



Coating

**A) Standard coating for material combination 01 up to 031:
non-potable water coating (potable water approval not available!)**

without extra charge		Inside	Outside
	Pretreatment	Derusting St 2 DIN 55928 T4	
	Primer	1-Component antirust primer red	
	Top coat	-without-	1-component-coat, thickness 0,06 mm RAL 5002 ultramarinblau (blue)

**B) Special coating for material combination 01 up to 031:
approved for potable water**

against extra charge see on list top coat inside+outside		Inside	Outside
	Pretreatment	Derusting St 2 DIN 55928 T4	
	Primer	1-Component antirust primer red	
	Top coat	2-component-epoxy resin based coat, thickness 0,125 mm, black RAL 9005, approved for potable water	1-component-coat, thickness 0,06 mm RAL 5002 ultramarinblau (blue)

**C) Special coating for material combination 01 up to 031:
approved for potable water**

against extra charge dependent on individual project		Inside	Outside
	Pretreatment	Blasting SA 2 1/2, DIN 55928 T4	
	Primer	2-Component epoxy resin based zinc dust paint, grey, thickness 0,04 mm ¹⁾	
	Top coat	2-component-epoxy resin based coat, thickness 0,125 mm, black RAL 9005, approved for potable water	coating according to customer's specification or by customer itself

¹⁾ Primer suitable for various top coats

Sectional drawing

Pump sizes 500-510 up to 500-890

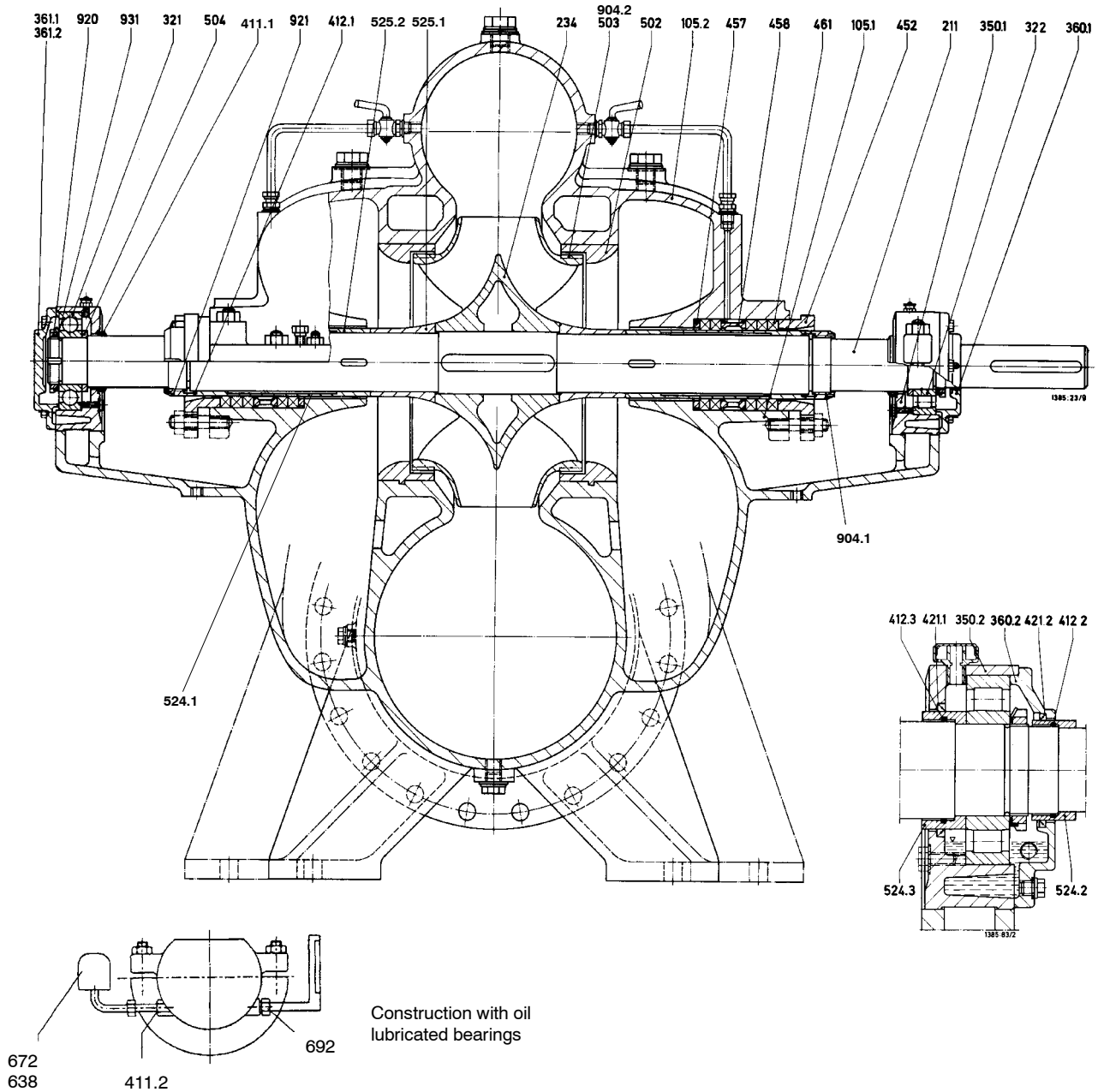

Construction with oil lubricated bearings

Part no.	Part designation	Part no.	Part designation
105.1-.2	Casing half	458	Lantern ring
211	Pump shaft	461	Gland packing
234	Double entry impeller	502	Casing wear ring
321	Radial ball bearing	503	Impeller wear ring
322	Radial roller bearing	504	Spacer ring
350.1-.2	Bearing housing	524.1-.3	Shaft protecting sleeve
360.1-.2	Bearing cover	525.1-.2	Spacer sleeve
361.1-.2	Bearing end cover	638	Constant level oiler
411.1	Joint ring	672	Venting device
411.2	Joint ring	692	Temperature measuring instrument
412.1-.3	O-ring	904.1-.2	Grub screw
421.1-.2	Radial shaft seal ring	920	Nut
452	Gland	921	Shaft nut
457	Neck ring	931	Lock washer

Sectional drawing

Pump sizes 600-540 up to 800-970

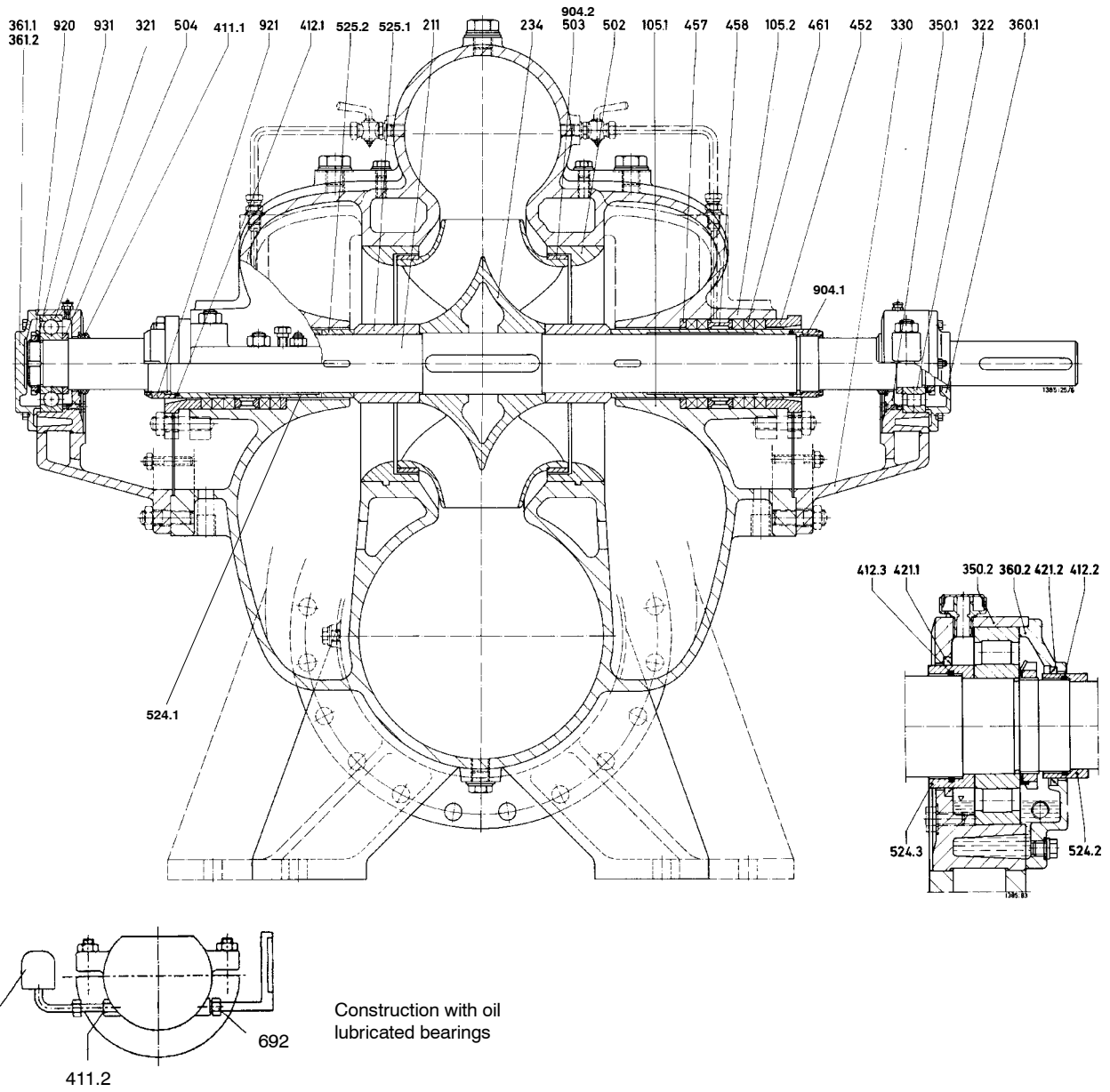

Part no.	Part designation	Part no.	Part designation
105.1-.2	Casing half	457	Neck ring
211	Pump shaft	458	Lantern ring
234	Double entry impeller	461	Gland packing
321	Radial ball bearing	502	Casing wear ring
322	Radial roller bearing	503	Impeller wear ring
330	Bearing bracket	504	Spacer ring
350.1-.2	Bearing housing	524.1-.3	Shaft protecting sleeve
360.1-.2	Bearing cover	525.1-.2	Spacer sleeve
361.1-.2	Bearing end cover	638	Constant level oiler
411.1	Joint ring	672	Venting device
411.2	Joint ring	692	Temperature measuring instrument
412.1-.3	O-ring	904.1-.2	Grub screw
421.1-.2	Radial shaft seal ring	920	Nut
452	Gland	921	Shaft nut
		931	Lock washer

Shaft seal

Uncooled soft-packed stuffing box or uncooled single acting, unbalanced mechanical seal, acc. to DIN 24960, independent of direction of rotation.

For operating pressure > 16 bar: balanced mechanical seal.

Stuffing box packing

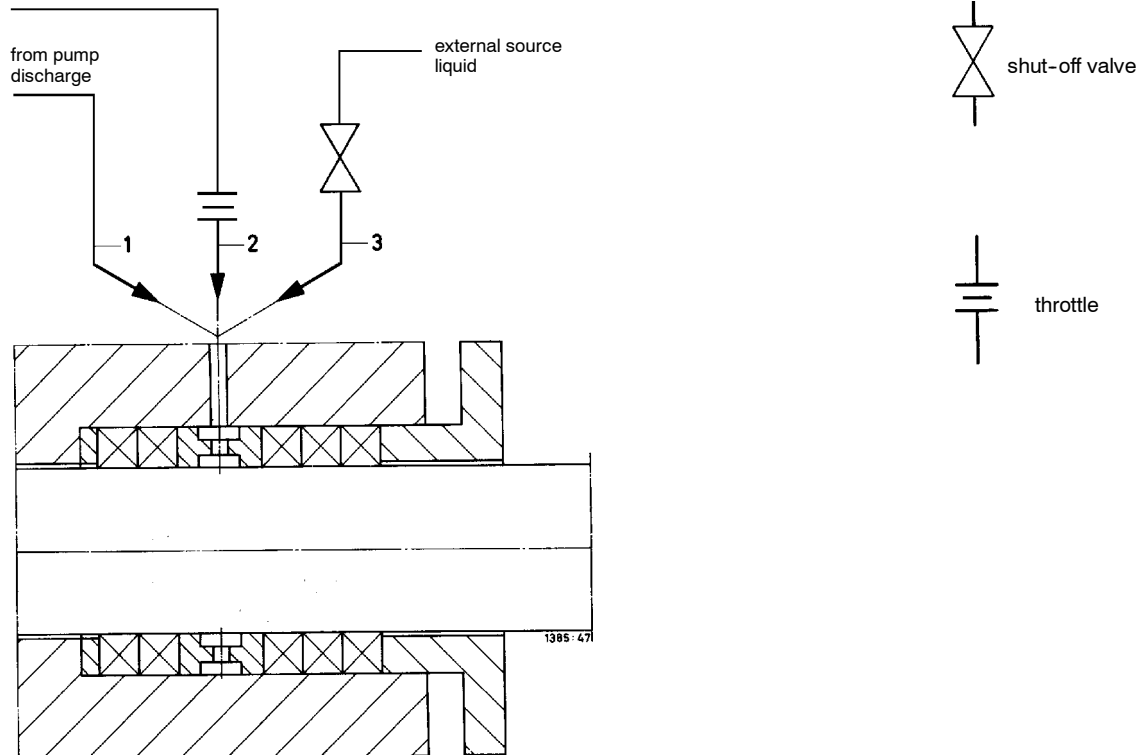

**Standard mechanical seal acc. to DIN 24960
for shaft seal diameter up to 100 mm
(Pump sizes 500-510 and 600-540)**

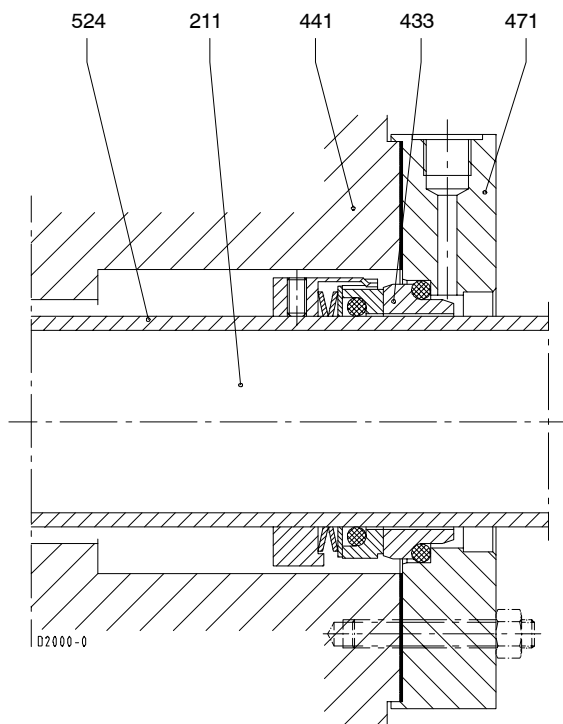

**Mechanical seal
Shaft seal for shaft seal diameter from 110 mm**

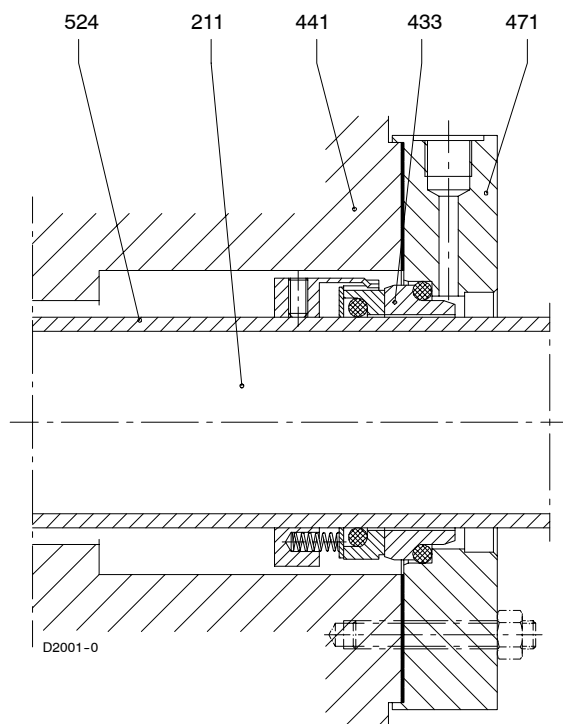

Part no.	Part designation
211	Shaft
433	Mechanical seal
441	Shaft seal housing
471	Seal cover
524	Shaft protecting sleeve

Dimension table for type of installation 2 E

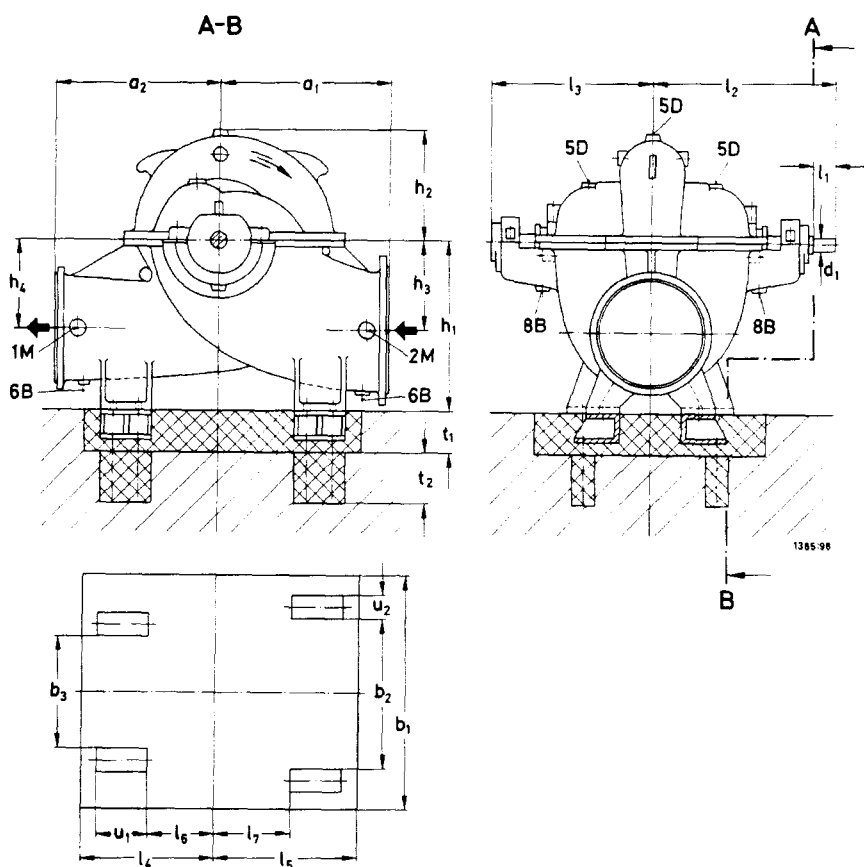

Permissible deviations of dimensions for:

Height of centre	DIN 747
Dimensions without indication of tolerances average to	DIN 7168
Cast iron parts	DIN 1686 GTB 18
Spheroidal graphite cast iron parts	DIN 1685 GTB 18
Cast steel parts	DIN 1683 GTB 18

R = B.S.P.

Key and keyway to DIN 6885

Shaft diameter: fit h_6 to DIN 7155

Connections

		from RDL 500-510	from RDL 700-590
1 M	Pressure gauge	R 1/2	R 1/2
2 M	Vacuum gauge	R 1/2	R 1/2
5 D	Vent	R 1	R 1 1/2
6 B	Drain	R 1	R 1 1/2
8 B	Dripping water	R 1	R 1



Pump sizes	Flanges		Pump dimensions								Shaft end		Weight of pump [kg]
	suction DN ₁	discharge DN ₂	a ₁	a ₂	h ₁	h ₂	h ₃	h ₄	l ₂	l ₃	d ₁	l ₁ *)	
500-510	600	500	850	550	900	560	475	475	1025	820	75	190	1528
500-640	600	500	850	800	920	600	495	495	1115	900	95	210	2301
500-700	600	500	1050	850	1000	620	550	620	1085	855	105	230	2967
500-790	600	500	1000	900	1050	660	600	600	1175	900	115	250	3483
500-890	600	500	1050	950	1100	710	650	650	1210	920	135	290	4659
600-540	700	600	1100	900	1100	750	610	610	1080	885	75	190	2725
600-620	700	600	1000	1000	1050	650	545	545	1060	840	85	225	2961
600-710	700	600	1000	1100	1050	650	545	545	1160	930	105	230	3427
600-830	700	600	1100	1200	1100	760	580	580	1275	1000	115	250	4700
700-590	800	700	1300	800	1150	720	600	600	1300	1090	95	210	4043
700-710	800	700	1200	1150	1170	750	620	620	1360	1130	105	230	5329
700-820	800	700	1250	1250	1200	850	650	650	1440	1160	125	305	6075
800-740	900	800	1400	950	1380	920	770	770	1410	1180	105	230	6557
800-840	900	800	1400	1125	1360	900	770	770	1500	1180	115	310	6624
800-970	900	800	1400	1300	1370	850	760	760	1580	1270	135	310	7809

Pump sizes	Foundation dimensions											Max. flange rating to DIN [bar]	
	b ₁	b ₂	b ₃	l ₄	l ₅	l ₆	l ₇	t ₁	t ₂	u ₁	u ₂	Casing material	
												GG-20 A48 class 30	GGG-40 A536 class 604018
500-510	1440	1000	700	460	610	140	290	220	300	220	120	10	16
500-640	1440	1000	700	660	660	340	340	220	300	220	120	10	25
500-700	1540	1100	700	710	810	390	490	220	300	220	120	16	25
500-790	1540	1100	725	760	860	440	540	220	300	220	120	25	25
500-890	1440	1000	750	810	910	490	590	220	300	220	120	25	25
600-540	1450	950	650	800	900	400	500	220	300	300	150	10	16
600-620	1450	950	650	900	900	500	500	220	300	300	150	10	16
600-710	1550	1050	750	900	900	500	500	220	300	300	150	16	25
600-830	1550	1050	750	1000	900	600	500	220	300	300	150	16	25
700-590	1440	940	640	700	1000	250	550	250	300	350	150	10	16
700-710	1440	940	640	1000	1000	550	55	250	300	350	150	10	16
700-820	1440	940	640	1050	1050	600	600	250	300	350	150	16	16
800-740	1540	1040	740	850	1000	350	500	250	300	400	150	10	16
800-840	1540	1040	740	1000	1050	500	550	250	300	400	150	10	16
800-970	1540	1040	740	1000	1100	600	600	250	300	400	150	10	16

Dimensions in mm, non-certified

*) Dimensions are for pumps with grease-lubricated bearings, with oil lubricated bearings shorten l₁ by 20 mm

We reserve the right to make technical changes

				Pos.-no.	Enclosure	
				Dimension Table RDL -		
				Project-no. / Works-no.	No.	
Date	Name	Change				

Dimension table for type of installation 4 E

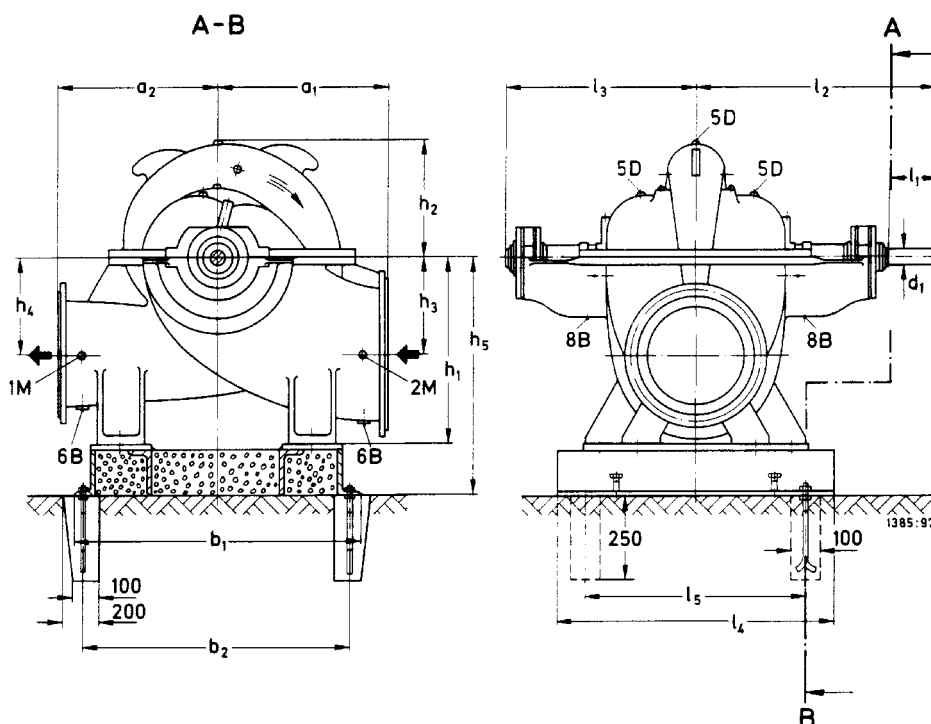

The base frame must be grouted in after alignment with self-hardening mortar.

Permissible deviations of dimensions for:

Height of centre	DIN 747
Dimensions without indication of tolerances average to	
Cast iron parts	DIN 1686 GTB 18
Spheroidal graphite cast iron parts	DIN 1685 GTB 18
Cast steel parts	DIN 1683 GTB 18

R = B.S.P.
 Key and keyway to DIN 6885
 Shaft diameter: fit h_6 to DIN 7155
 DIN 7168

Connections

		from RDL 500-510	from RDL 700-590
1 M	Pressure gauge	R 1/2	R 1/2
2 M	Vacuum gauge	R 1/2	R 1/2
5 D	Vent	R 1	R 1 1/2
6 B	Drain	R 1	R 1 1/2
8 B	Dripping water	R 1	R 1



Pump size	Flanges		Pump dimensions								Shaft end		Weight of pump [kg]
	suction DN ₁	discharge DN ₂	a ₁	a ₂	h ₁	h ₂	h ₃	h ₄	l ₂	l ₃	d ₁	l ₁ *)	
500-510	600	500	850	550	900	560	475	475	1025	820	75	190	1528
500-640	600	500	850	800	920	600	495	495	1115	900	95	210	2301
500-700	600	500	1050	850	1000	620	550	620	1085	855	105	230	2967
500-790	600	500	1000	900	1050	660	600	600	1175	900	115	250	3483
500-890	600	500	1050	950	1100	710	650	650	1210	920	135	290	4659
600-540	700	600	1100	900	1100	750	610	610	1080	885	75	190	2725
600-620	700	600	1000	1000	1050	650	545	545	1060	840	85	225	2961
600-710	700	600	1000	1100	1050	650	545	545	1160	930	105	230	3427
600-830	700	600	1100	1200	1100	760	580	580	1275	1000	115	250	4700
700-590	800	700	1300	800	1150	720	600	600	1300	1090	95	210	4043
700-710	800	700	1200	1150	1170	750	620	620	1360	1130	105	230	5329
700-820	800	700	1250	1250	1200	850	650	650	1440	1160	125	305	6075
800-740	900	800	1400	950	1380	920	770	770	1410	1180	105	230	6557
800-840	900	800	1400	1125	1360	900	770	770	1500	1180	115	310	6624
800-970	900	800	1400	1300	1370	850	760	760	1580	1270	135	310	7809

Pump size	Baseframe dimensions					Max. flange rating to DIN [bar]	
						Casing material	
	b ₁	b ₂	h ₅	l ₄	l ₅	GG-20 A48 class 30	GGG-40 A536 class 604018
500-510	1300	1220	1100	1150	850	10	16
500-640	1400	1320	1130	1150	850	10	25
500-700	1700	1620	1210	1250	950	16	25
500-790	1800	1720	1260	1250	950	25	25
500-890	1900	1820	1310	1150	850	25	25
600-540	1800	1720	1310	1150	850	10	16
600-620	1800	1720	1260	1150	850	10	16
600-710	1800	1720	1260	1250	950	16	25
600-830	2000	1920	1310	1250	950	16	25
700-590	2000	1920	1360	1250	950	10	16
700-710	2000	1920	1380	1250	950	10	16
700-820	2100	2020	1410	1250	950	16	16
800-740	2000	1920	1590	1350	1050	10	16
800-840	2100	2020	1570	1350	1050	10	16
800-970	2200	2120	1580	1350	1050	10	16

Dimensions in mm, non-certified

*) Dimensions are for pumps with grease-lubricated bearings, with oil lubricated bearings shorten l₁ by 20 mm

We reserve the right to make technical changes

				Pos.-no.	Enclosure	
				Dimension Table RDL -		
				Project-no. / Works-no.	No.	
Date	Name	Change				

Spare parts**Proposals for Spare Parts for 2 - Years Operation (8000 hours per year)**

Pump with soft packed Stuffing Box

Part No.	Part Designation	No. of Pumps including Stand-By Pumps							
		1	2	3	4	5	6	8	10 and more
		No. of Spare Parts							
211 920 921 940	Shaft, with Nut Shaft nut Key	-	-	-	1	1	1	2	3
234	Impeller	-	-	-	1	1	1	2	3
321 / 322	Set Bearings	1	1	1	2	2	3	4	5
452	Set Gland	-	-	-	1	1	1	2	3
411.1 412.1 - 3 421.1/2	Set Joint-Ring O-Ring Radial shaft seal ring	1	2	3	4	5	6	8	10
461	Set Gland packing	4	8	12	16	20	24	32	40
457	Set neck rings	-	-	-	1	1	1	2	3
458	Set lantern rings	-	-	-	1	1	1	2	3
502	Set casing wear rings	1	1	1	2	2	3	4	5
503 904.2	Set impeller wear rings Grub screw	1	1	1	2	2	3	4	5
524.1 - 3	Set shaft protec. sleeves	1	1	1	2	2	3	4	5
525.1-2	Distance sleeve	1	1	1	2	2	3	4	5

Pump with Mechanical Seal

Part No.	Part Designation	No. of Pumps including Stand-By Pumps							
		1	2	3	4	5	6	8	10 and more
		No. of Spare Parts							
211 920 921 940	Shaft, with Nut Shaft nut Key	-	-	-	1	1	1	2	3
234	Impeller	-	-	-	1	1	1	2	3
321 / 322	Set Bearings	1	1	1	2	2	3	4	5
411.1 412.1 - 3 421.1/2	Set Joint-Ring O-Ring Radial shaft seal ring	1	2	3	4	5	6	8	10
433	Set mechanical seals	1	1	1	2	2	3	4	5
502	Set casing wear rings	1	1	1	2	2	3	4	5
503 904.2	Set impeller wear rings Grub screw	1	1	1	2	2	3	4	5
524.1 - 3	Set shaft protec. sleeves	1	1	1	2	2	3	4	5
525.1-2	Distance sleeve	1	1	1	2	2	3	4	5



Proposals for Spare Parts for 5 - Years Operation (8000 hours per year)

Pump with soft packed Stuffing Box

Part No.	Part Designation	No. of Pumps including Stand-By Pumps							
		1	2	3	4	5	6	8	10 and more
		No. of Spare Parts							
211 920 921 940	Shaft, with Nut Shaft nut Key	1	1	1	2	2	2	4	6
234	Impeller	1	1	1	2	2	2	4	6
321 / 322	Set Bearings	2	2	2	4	4	6	8	10
452	Set Gland	1	1	1	2	2	2	4	6
411.1 412.1 - 3 421.1/2	Set Joint-Ring O-Ring Radial shaft seal ring	2	2	6	8	8	12	16	20
461	Set Gland packing	10	20	30	40	50	60	80	100
457	Set neck rings	1	1	1	2	2	2	4	6
458	Set lantern rings	1	1	1	2	2	2	4	6
502	Set casing wear rings	2	2	2	4	4	6	8	10
503 904.2	Set impeller wear rings Grub screw	2	2	2	4	4	6	8	10
524.1 - 3	Set shaft protec. sleeves	2	2	2	4	4	6	8	10
525.1-2	Distance sleeve	2	2	2	4	4	6	8	10

Pump with Mechanical Seal

Part No.	Part Designation	No. of Pumps including Stand-By Pumps							
		1	2	3	4	5	6	8	10 and more
		No. of Spare Parts							
211 920 921 940	Shaft, with Nut Shaft nut Key	1	1	1	2	2	2	4	6
234	Impeller	1	1	1	2	2	2	4	6
321 / 322	Set Bearings	2	2	2	4	4	6	8	10
411.1 412.1 - 3 421.1/2	Set Joint-Ring O-Ring Radial shaft seal ring	2	2	6	8	8	12	16	20
433	Set mechanical seals	2	2	2	4	4	6	8	10
502	Set casing wear rings	2	2	2	4	4	6	8	10
503 904.2	Set impeller wear rings Grub screw	2	2	2	4	4	6	8	10
524.1 - 3	Set shaft protec. sleeves	2	2	2	4	4	6	8	10
525.1-2	Distance sleeve	2	2	2	4	4	6	8	10

Accessories

- 1 shock pulse monitoring stud
- 1 set seal pipe with 1 cyclone separator (for handling contaminated fluids)
including:
 - cyclone separator plastic
 - flow indicator of stainless steel
 - shut-off valve of stainless steel
 - connectors + piping of stainless steel
- 1 vent valve, manually operated of stainless steel
including:
 - connectors
- 1 temperature monitoring devise for antifriction bearings
for each bearing consisting of:
 - 1 resistance thermometer PT 100,
2-wire system, with 2m connection cable
 - 1 adaptor of stainless steel
- 1 signal transmitter for PT 100 control room mounting
 - output signal 0-20 mA, voltage optional AC 110 V or 220 V
- 1 set pressure gauges acc. to DIN 16064
consisting of:
 - 1 pressure gauge BSP 1/2, 100 mm, grade of quality 1,0
 - 1 pressure-vacuum gauge BSP 1/2, 100 mm, grade of quality 1,0
 - 2 pressure gauge cocks BSP 1/2 incl. brackets

