

Grundfos RSI

AC Drives

Installation and operating instructions



English (GB) Installation and operating instructions

Original installation and operating instructions

CONTENTS

| | | | |
|--|------------|------------------------------|-----------|
| | 9.5 | Connections | 88 |
| | 9.6 | Commissioning | 93 |
| | 9.7 | Parameters and fault tracing | 94 |
| | 9.8 | Maintenance and diagnostics | 94 |
| | 10. | Disposal | 94 |

| | | | |
|--|-------------|--|--|
| | Page | | |
| 1. Symbols used in this document | 2 | | |
| 1.1 Units | 3 | | |
| 1.2 Danger | 3 | | |
| 1.3 Warnings | 4 | | |
| 1.4 Earthing and earth fault protection | 5 | | |
| 1.5 Insulation system | 8 | | |
| 1.6 Compatibility with RCDs | 9 | | |
| 1.7 Extended temperature range | 9 | | |
| 1.8 Electro-magnetic compatibility (EMC) | 9 | | |
| 2. Receipt of delivery | 10 | | |
| 2.1 Type designation code | 11 | | |
| 2.2 Product numbers | 12 | | |
| 2.3 Unpacking and lifting the AC drive | 12 | | |
| 2.4 Accessories | 13 | | |
| 3. Mounting | 15 | | |
| 3.1 Dimensions Frame A | 15 | | |
| 3.2 Dimensions Frame B | 16 | | |
| 3.3 Dimensions Frame C | 17 | | |
| 3.4 Introduction of modules | 18 | | |
| 3.5 Mounting | 18 | | |
| 3.6 Cooling | 19 | | |
| 4. Power cabling | 20 | | |
| 4.1 Circuit breaker | 21 | | |
| 4.2 UL standards on cabling | 21 | | |
| 4.3 Description of the terminals | 22 | | |
| 4.4 Cable dimensioning and selection | 25 | | |
| 4.5 Cable installation | 27 | | |
| 5. Control unit | 33 | | |
| 5.1 Control unit cabling | 34 | | |
| 5.2 I/O cabling and Fieldbus connection | 39 | | |
| 5.3 Battery installation for Real Time Clock (RTC) | 42 | | |
| 6. Commissioning | 43 | | |
| 6.1 Commissioning of the drive | 43 | | |
| 6.2 Changing EMC protection class | 44 | | |
| 6.3 Running the motor | 46 | | |
| 6.4 Maintenance | 46 | | |
| 7. Technical data | 47 | | |
| 7.1 AC drive power ratings | 47 | | |
| 7.2 Brake resistor ratings | 49 | | |
| 7.3 Grundfos RSI - technical data | 50 | | |
| 8. Options | 55 | | |
| 8.1 Control Keypad | 59 | | |
| 8.2 Heater (arctic option) | 81 | | |
| 8.3 Option boards | 84 | | |
| 9. Safe Torque Off | 85 | | |
| 9.1 General description | 85 | | |
| 9.2 Warnings | 85 | | |
| 9.3 Standards | 86 | | |
| 9.4 The principle of STO | 87 | | |

This manual contains clearly marked warning information which is intended for your personal safety and to avoid any unintentional damage to the product or connected appliances.

Please read the warning information carefully.

Grundfos RSI is a drive designed to control asynchronous AC motors and permanent magnet motors. The product is intended to be installed in a restricted access location and for a general purpose use.

Only Grundfos authorized, trained and qualified personnel are allowed to install, operate and maintain the drive.

1. Symbols used in this document

The cautions and warnings are marked as follows:



Warning

If these safety instructions are not observed, it may result in personal injury.



Warning

If these instructions are not observed, it may lead to electric shock with consequent risk of serious personal injury or death.



Warning

The surface of the product may be so hot that it may cause burns or personal injury.

1.1 Units

The dimensions used in this manual conform to International Metric System units, otherwise known as SI (Système International d'Unités) units. For the purpose of the equipment's UL certification, some of these dimensions are accompanied by their imperial equivalents.

Unit conversion table

| Physical dimension | SI value | US value | Conversion factor | US designation |
|--------------------|---------------------|--------------|--------------------|-----------------------|
| length | 1 mm | 0.0394 inch | 25.4 | inch |
| Weight | 1 kg | 2.205 lb | 0.4536 | pound |
| Speed | 1 min ⁻¹ | 1 rpm | 1 | revolution per minute |
| Temperature | 1 °C (T1) | 33.8 °F (T2) | T2 = T1 x 9/5 + 32 | Fahrenheit |
| Torque | 1 Nm | 8.851 lbf in | 0.113 | pound-force inches |
| Power | 1 kW | 1.341 HP | 0.7457 | horsepower |

1.2 Danger

Warning



The components of the power unit of Grundfos RSI drives are live when the drive is connected to mains potential. Coming into contact with this voltage is extremely dangerous and may cause death or severe injury.

Warning



The motor terminals (U, V, W), the brake resistor terminals and the DC-terminals are live when Grundfos RSI Drive is connected to the mains, even if the motor is not running.

Warning



After disconnecting the AC drive from the mains, wait until the indicators on the keypad go out (if no keypad is connected, see the indicators on the cover). Wait an additional 30 seconds before doing any work on the connections of Grundfos RSI Drive. Do not open the unit before this time has expired. After expiration of this time, use measuring equipment to absolutely ensure that no voltage is present. Always ensure absence of voltage before starting any electrical work!

Warning



The control I/O-terminals are isolated from the mains potential. However, the relay outputs and other I/O-terminals may have a dangerous control voltage present even when Grundfos RSI drive is disconnected from the mains.

Warning



Before connecting the AC drive to mains make sure that the powerhead of Grundfos RSI Drive is mounted firmly on the terminal box.

Warning



During a coast stop (see the Application Manual), the motor is still generating voltage to the drive. Therefore, do not touch the components of the AC drive before the motor has completely stopped and wait until the indicators on the keypad go out (if no keypad is connected, see the indicators on the cover). Wait an additional 30 seconds before starting any work on the drive.

1.3 Warnings



Warning

Grundfos RSI AC drive is meant for fixed installations (on the motor or on the wall) only.

Warning

Only DVC A circuits (Decisive Voltage Class A, according to IEC 61800-5-1) are allowed to be connected to the control unit. This advice aims to protect both the drive and the client-application. Grundfos is not responsible for direct or consequential damages resulting from unsafe connections of external circuits to the drive. See paragraph 1.5 for more details.



Warning

Do not perform any measurements when the AC drive is connected to the mains.



Warning

The touch current of Grundfos RSI AC drives exceeds 3.5 mA AC. According to standard EN61800-5-1, a reinforced protective ground connection must be ensured. See paragraph [1.4 Earthing and earth fault protection](#) for more details.



Warning

If the AC drive is used as a part of a machine, the machine manufacturer is responsible for providing the machine with a supply disconnecting device (EN 60204-1). See section [4.1 Circuit breaker](#) for more details.



Warning

Only spare parts delivered by Grundfos can be used.



Warning

At power-up or fault reset, the motor will start immediately if the start signal is active, unless the pulse control for Start/ Stop logic has been selected) and the STO inputs are ready to be used (normal operation). The I/O functionalities (including start inputs) may change if parameters, applications or software are changed. Disconnect, therefore, the motor if an unexpected start can cause danger. This is valid only if STO inputs are energized. For prevention on unexpected restart, use appropriate safety relay connected to the STO inputs.



Warning

The motor starts automatically after automatic fault reset if the autoreset function is activated. See the Application Manual for more detailed information. This is valid only if STO inputs are energized. For prevention on unexpected restart, use appropriate safety relay connected to the STO inputs.



Warning

Before performing any measurement on the motor or on the motor cable, disconnect the motor cable from the AC drive.



Warning

Do not touch the components on the circuit boards. Static voltage discharge may damage the components.



Warning

Check that the EMC level of the AC drive corresponds to the requirements of your supply network. See section 6.2 for more details.



Warning

In a domestic environment, this product may cause radio interference in which case supplementary mitigation measures may be required.



Warning

Optional keypad is IP66/Type 4X outdoor rated. Strong exposure to direct sunlight or to heavy temperatures might cause the degradation of display LCD.



1.4 Earthing and earth fault protection

Warning



The Grundfos RSI AC drive must always be earthed with an earthing conductor connected to the earthing terminal marked with .

See section 4.4.1 Cable and fuse sizes, frames A to C and 4.4.2 Cable and fuse sizes, frames A to C, North America for the required cross-section of phase conductor and protective earthing conductor (both made of copper).

Since the touch current exceeds 3.5 mA AC, according to EN61800-5-1, the A and B shall have a fixed connection and provision of an additional terminal for a second protective earthing conductor of the same cross-sectional area as the original protective earthing conductor. C shall have a fixed installation and a cross-section of the protective earthing conductor of at least 10 mm² Cu.

On the terminal-box, **three screws** (for A and B) and two screws (for C) are provided for ORIGINAL and MOTOR protective earthing conductors: the customer can choose the screw for each one.

The cross-sectional area of every protective earthing conductor which does not form a part of the supply cable or cable enclosure shall, in any case, be not less than:

- 2.5 mm² if mechanical protection is provided or
 - 4 mm² if mechanical protection is not provided.
- For cord-connected equipment, provisions shall be made so that the protective earthing conductor in the cord shall, in the case of failure of the strain-relief mechanism, be the last conductor to be interrupted.

The power-head is earthed through metal aglets, located on the terminal-box, which fit into spring baskets on the powerhead. See figs 1, 2 and 3 for the location of the screws (three for A and B, two for C) and the metal aglets (one for A and B, two for C). Please, pay attention not to damage or remove these aglets.

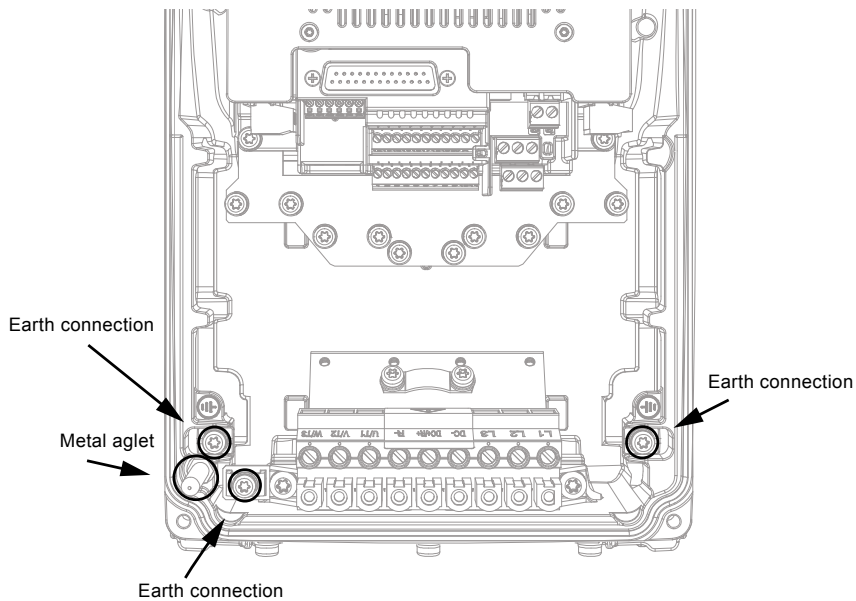

Fig. 1 Earth connections and metal aglet in A

TM06 7158 2916

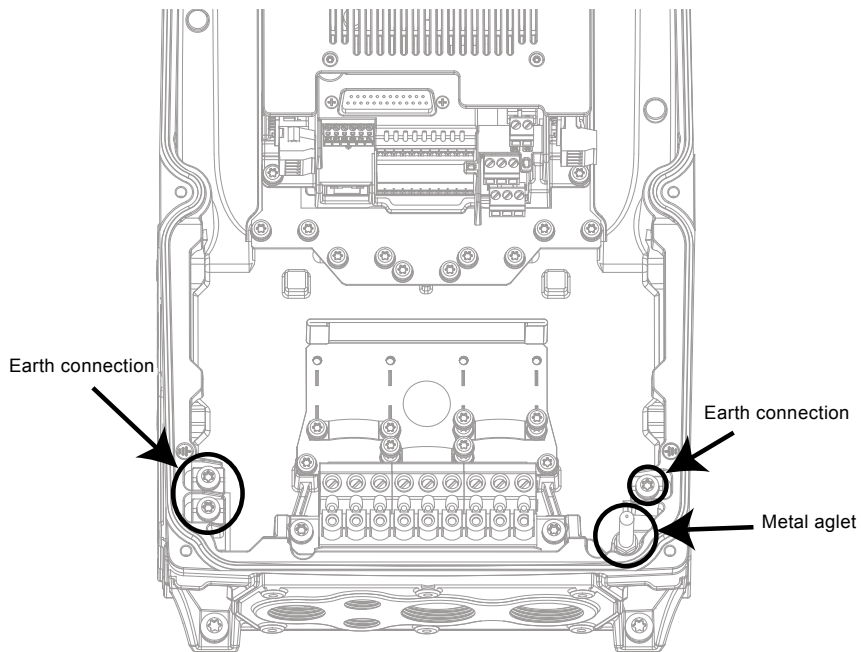

Fig. 2 Earth connections and metal aglet in B

TM06 7024 2916

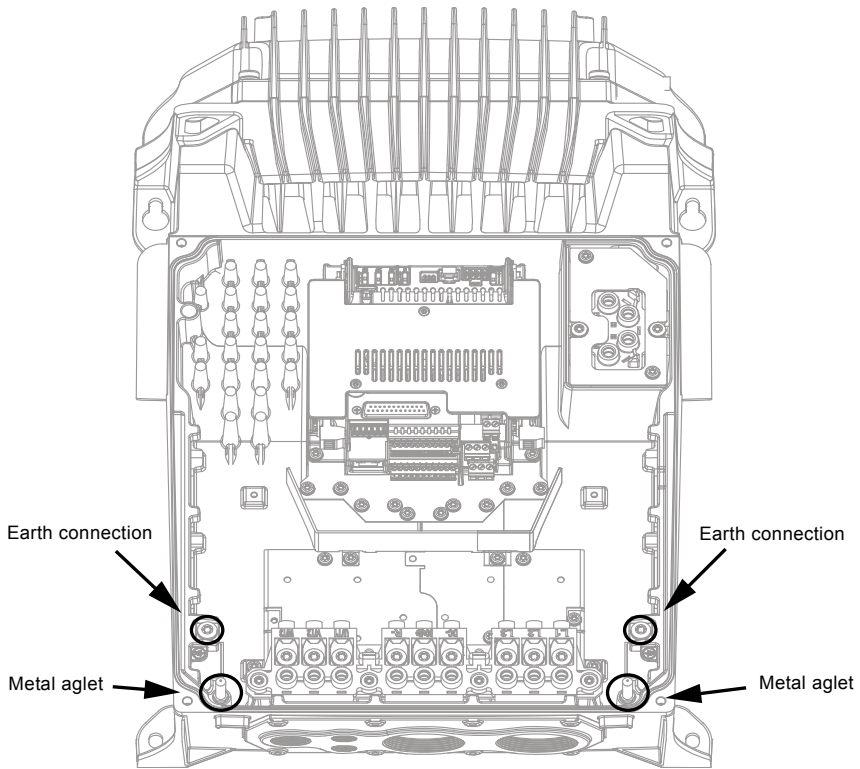

Fig. 3 Earth connections and metal aglet in C

However, always follow the local regulations for the minimum size of the protective earthing conductor.

Note

Due to the high capacitive currents present in the AC drive, fault current protective switches may not function properly.

TM06 7159 2916

1.5 Insulation system



Please, consider carefully the insulation system depicted in Figure 4 before connecting any circuit to the unit.

A distinction has to be made for the following three groups of terminals, according the insulation system of Grundfos RSI:

- Mains and motor connections (L1, L2, L3, U, V, W)
- Relays (R01, R02)^(*)
- Thermistor-input
- Control terminals (I/Os, RS485, Ethernet, STO)

The Control terminals (I/Os, RS485, Ethernet, STO) are isolated from the Mains (the insulation is reinforced, according to IEC 61800-5-1) and the GND terminals are referred to PE.

This is important when you need to connect other circuits to the drive and test the complete assembly. Should you have any doubt or question, please contact your local Grundfos distributor.

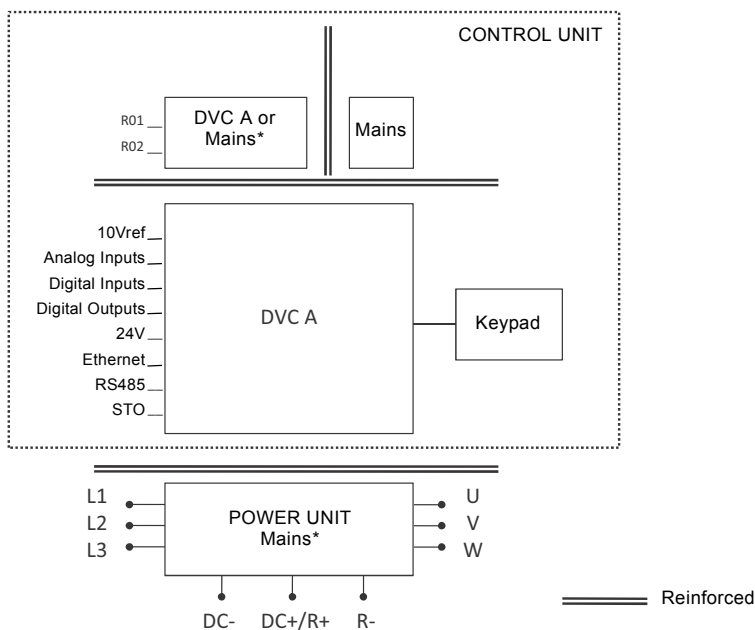

Fig. 4 Insulation system



* The relays may be used also with DVC A circuits. This is possible only if both relays are used with DVC A circuit: to mix Mains and DVC A is not allowed.

1.6 Compatibility with RCDs



This product can cause a d.c. current in the protective earthing conductor. Where a residual current-operated protective (RCD) or monitoring (RCM) device is used for protection in case of direct or indirect contact, only an RCD or RCM of Type B is allowed on the supply side of this product.

1.7 Extended temperature range

Grundfos RSI has an integrated cooling system, independent from the motor fan. Under maximum operating conditions, the ambient temperature cannot exceed 40 °C. See [7.1.1 Mains voltage 3 AC 208-240 V](#) and [7.1.2 Mains voltage 3 AC 380-480/500 V](#) for the output rated current. Higher temperatures are allowed only with derating of the output current. With derating the unit can operate up to 60 °C. See fig. 5.

Temperature - Output Current Derating Curve

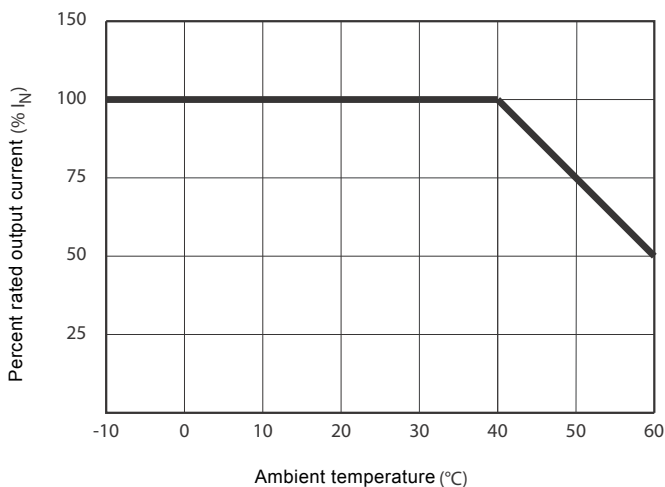

Fig. 5 Temperature-output current derating curve

The maximum allowed switching frequency above 50 °C (122 °F) is 1.5 kHz.

Note

The AC drive is cooled down by air-ventilation. Therefore, make sure that enough free space is left around the AC drive to ensure sufficient air circulation (see for more details the mounting instructions on section [3. Mounting](#)).

1.8 Electro-magnetic compatibility (EMC)

The Grundfos RSI complies with IEC 61000-3-12, provided that the short circuit power (SSC) is greater than or equal to 120 at the interface point between the user's supply and the public system. It is the responsibility of the installer or user of the equipment to ensure, by consultation with the distribution network operator if necessary, that the equipment is connected only to a supply with a short-circuit power SSC greater than or equal to 120.

TM06 6977 2916

2. Receipt of delivery

Check the correctness of delivery by comparing your order data to the drive information found on the package label. If the delivery does not correspond to your order, contact the supplier immediately. See section [2.4 Accessories](#).

AC DRIVE B.ID: 160120

Type: RSI0100-3L-0016-4-X

S/N: M160300033 

Code: 70SCO00000

141F6022



5 712605 678540



(93)98044434498

INPUT: U1: 3AC 380-480 V 50/60 Hz, I1: 15.4 A
DC 400-800 V

OUTPUT: U2: 3AC 0-Input V 0-320 Hz, I2: 16 A

POWER: P2: 7.5 kW: 400 V / 10 hp: 480 V
IP66

Firmware: FW0238V001 

Application: 

Cust. Ord. No: 12345678

Marks:

Grundfos Holding A/S, Denmark

Made in Italy
Grundfos A/S, 8850 Bjerringbro,
Denmark

GRUNDFOS 

TIM06 7492 3416

Fig. 6 Grundfos package label

2.1 Type designation code

Grundfos type designation code is formed of a nine-segment code and optional +codes. Each segment of the type designation code uniquely corresponds to the product and options you have ordered. The code is of the following format:

| Code | Example | RSI | 0100 | -3L | -0003 | -4 | -X | +HMGR |
|--------------|---|-----|------|-----|-------|----|----|-------|
| RSI | = Renewable Solar Inverter | | | | | | | |
| 0100 | Product Type | | | | | | | |
| 3L | Three-phase power | | | | | | | |
| 0003 0072 | Rated Current [A] 0072 = 72 A | | | | | | | |
| 2 4 | Supply voltage: 208-240 V 380-415 V | | | | | | | |
| X | Enclosure Class IP66 | | | | | | | |
| HMGR | Option (HMGR: Control panel with graphical display) | | | | | | | |

2.2 Product numbers

2.2.1 Low voltage range (3 x 208-240 V).

| Power [kW] | Product number | Electrical data | | Frame size |
|------------|----------------|-----------------|--------------------------|------------|
| | | Max. P2 [kW] | Rated output current [A] | |
| 1.5 (2) | 99090622 | 1.5 (2) | 8 | A |
| 2.2 (3) | 99090633 | 2.2 (3) | 11 | A |
| 3.0 (4) | 99090634 | 3.0 (4) | 12.5 | A |
| 4.0 (5) | 99090635 | 4.0 (5) | 18 | B |
| 5.5 (7.5) | 99090636 | 5.5 (7.5) | 24.2 | B |
| 7.5 (10) | 99090637 | 7.5 (10) | 31 | B |
| 11 (15) | 99090638 | 11 (15) | 48 | C |
| 15 (20) | 99090639 | 15 (20) | 62 | C |

2.2.2 High voltage range (3 x 380-440 V)

| Power [kW] | Product number | Electrical data | | Frame size |
|------------|----------------|-----------------|--------------------------|------------|
| | | Max. P2 [kW] | Rated output current [A] | |
| 2.2 (3) | 99044348 | 2.2 (3) | 5.6 | A |
| 3.0 (4) | 99044349 | 3.0 (4) | 8 | A |
| 4.0 (5) | 99044350 | 4.0 (5) | 9.6 | A |
| 5.5 (7.5) | 99044351 | 5.5 (7.5) | 12 | A |
| 7.5 (10) | 99044352 | 7.5 (10) | 16 | B |
| 11 (15) | 99044363 | 11 (15) | 23 | B |
| 15 (20) | 99044364 | 15 (20) | 31 | B |
| 18.5 (25) | 99044365 | 18.5 (25) | 38 | C |
| 22 (30) | 99044366 | 22 (30) | 46 | C |
| 30 (40) | 99044367 | 30 (40) | 61 | C |
| 37 (50) | 99044368 | 37 (50) | 72 | C |

Product numbers for Grundfos RSI. See section [7. Technical data](#) for more details.

2.3 Unpacking and lifting the AC drive

The weights of the AC drives vary according to frame size. You may need to use a piece of special lifting equipment to move the converter from its package. Note the weights of each individual frame size in the table below.

Frame weights

| Frame | Weight | |
|-------|--------|------|
| | [kg] | [lb] |
| A | 8.8 | 19.4 |
| B | 14.9 | 32.8 |
| C | 31.5 | 69.4 |

Grundfos RSI drives have undergone scrupulous tests and quality checks at the factory before they are delivered to the customer. However, after unpacking the product, check that no signs of transport damage are to be found on the product and that the delivery is complete.

Should the drive have been damaged during shipping, please contact the cargo insurance company or the carrier in the first instance.

2.4 Accessories

After having opened the transport package and lifted the drive out, check immediately that these various accessories were included in the delivery. The contents of the accessories bag differ by drive size:

2.4.1 Frame A

Content of accessory bag, A

| Item | Quantity | Purpose |
|--|----------|--|
| STO terminal connector | 1 | Six pin black connector (see fig. 7) to use STO function |
| M4 x 12 DIN6900-3-Combi-Delta-Tx screw | 10 | Screws for control cable clamps |
| M1-3 Cable clamp | 5 | Clamping control cables |
| M4 x 12 DIN6900-3-Combi-Delta-Tx screw | 6 | Screws for power cable clamps |
| M25 Cable clamp | 3 | Clamping power cables |
| "Product modified" sticker | 1 | Information about modifications |
| HMI cap* | 1 | Closing cap for the HMI connector |

* Provided only if the drive is delivered with the keypad.

2.4.2 Frame B

Content of accessory bag, C

| Item | Quantity | Purpose |
|--|----------|--|
| STO terminal connector | 1 | Six pin black connector (see fig. 7) to use STO function |
| M4 x 12 DIN6900-3-Combi-Delta-Tx screw | 10 | Screws for control cable clamps |
| M1-3 Cable clamp | 5 | Clamping control cables |
| M4 x 12 DIN6900-3-Combi-Delta-Tx screw | 6 | Screws for power cable clamps |
| M32 Cable clamp | 3 | Clamping power cables |
| "Product modified" sticker | 1 | Information about modifications |
| HMI cap* | 1 | Closing cap for the HMI connector |

* Provided only if the drive is delivered with the keypad.

2.4.3 Frame C

Content of accessory bag, C

| Item | Quantity | Purpose |
|--|----------|--|
| STO terminal connector | 1 | Six pin black connector (see fig. 7) to use STO function |
| M4 x 12 DIN6900-3-Combi-Delta-Tx screw | 10 | Screws for control cable clamps |
| M1-3 Cable clamp | 5 | Clamping control cables |
| M4 x 25 DIN6900-3-Combi-Delta-Tx screw | 6 | Screws for power cable clamps |
| M40 Cable clamp | 3 | Clamping power cables |
| "Product modified" sticker | 1 | Information about modifications |
| HMI cap* | 1 | Closing cap for the HMI connector |

* Provided only if the drive is delivered with the keypad.

2.4.4 STO terminal connector

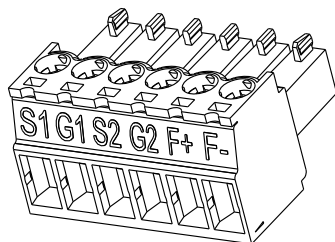

TM06 7147 2916

Fig. 7 STO connector

2.4.5 "Product modified" sticker

In the small plastic bag included in the delivery you will find a silver Product modified sticker. The purpose of the sticker is to notify the service personnel about the modifications made in the AC drive. Attach the sticker on the side of the AC drive to avoid losing it. Should the AC drive be later modified mark the change on the sticker.

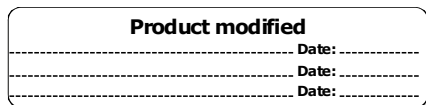

TM06 7138 2916

Fig. 8 "Product modified" sticker

2.4.6 Disposal

When the device reaches the end of its operating life do not dispose of it as a part of standard household garbage. Main components of the product can be recycled, but some need to be fragmented to separate different types of materials and components that need to be treated as special waste from electrical and electronic components. To ensure environmentally sound and safe recycling treatment, the product can be taken to appropriate recycling center or returned to the manufacturer.

Observe local and other applicable laws as they may mandate special treatment for specific components or special treatment may be ecologically sensible.

3. Mounting

Grundfos RSI is the ideal solution for a decentralised installation. It is conceived to be mounted on a wall or directly on the motor, saving space and reducing the cabling complexity. In both of the cases, it must be ensured that the mounting plane is even.

3.1 Dimensions Frame A

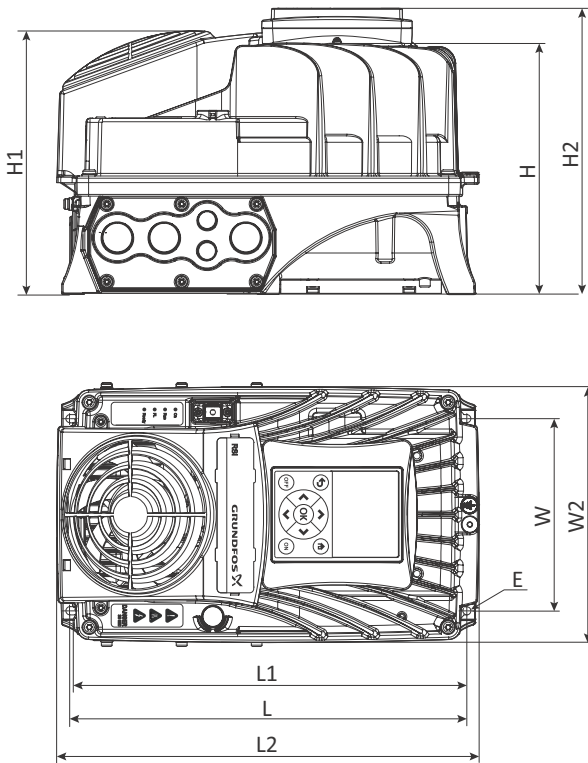

Fig. 9 Frame A 1,5 - 5,5 kW (2 - 7.5 hp)

TM06 6526 1813

| Product | | | | | | | | | | |
|------------|--------------------------|-------------------|-------------------|--------------------|-------------------|--------------------|--------------------|-------------------|--------------------|--------------------|
| Frame Size | Net weight [kg (lbs)] | E [mm (in)] | W [mm (in)] | W2 [mm (in)] | L [mm (in)] | L1 [mm (in)] | L2 [mm (in)] | H [mm (in)] | H1 [mm (in)] | H2 [mm (in)] |
| Frame A | 8.8 (19) | Ø5.9 (0.23) | 143.5 (5.7) | 191 (7.5) | 297 (11.7) | 293 (11.5) | 315 (12.4) | 188 (7.4) | 197 (7.8) | 214 (8.4) |

| Package | | | | |
|------------|----------------------------|---------------------|--------------------|---------------------|
| Frame Size | Gross weight [kg (lbs)] | Length [mm (in)] | Width [mm (in)] | Height [mm (in)] |
| Frame A | 310 (683) | 250 (9.8) | 200 (7.9) | 295 (11.6) |

3.2 Dimensions Frame B

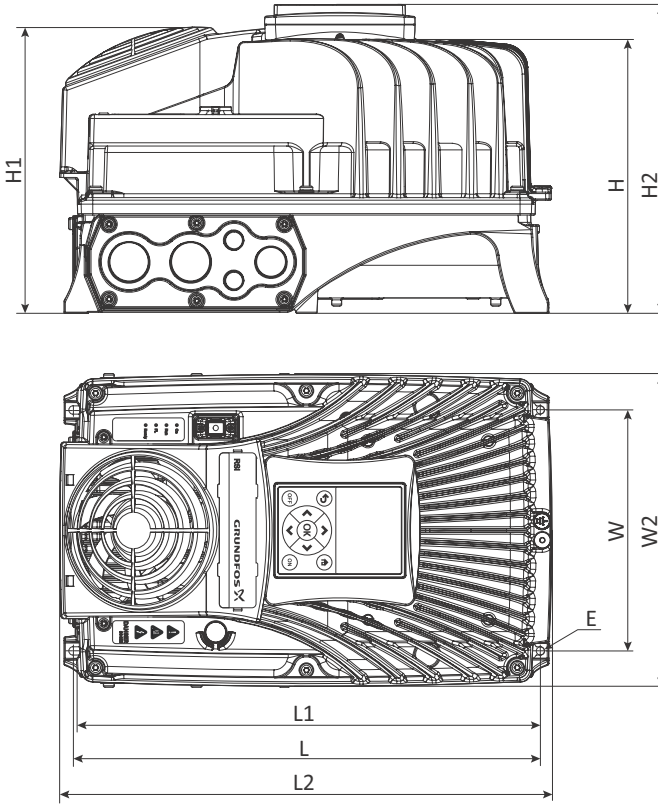

Fig. 10 Frame B 7,5 - 15 kW (10 - 20 hp)

TM06 6527 1813

| Product | | | | | | | | | | |
|------------|--------------------------|-------------------|-------------------|--------------------|-------------------|--------------------|--------------------|-------------------|--------------------|--------------------|
| Frame Size | Net weight [kg (lbs)] | E [mm (in)] | W [mm (in)] | W2 [mm (in)] | L [mm (in)] | L1 [mm (in)] | L2 [mm (in)] | H [mm (in)] | H1 [mm (in)] | H2 [mm (in)] |
| Frame B | 15 (33) | Ø6.1 (0.24) | 180 (7.1) | 233 (9.2) | 349 (13.7) | 345.2 (13.6) | 368 (14.5) | 204 (8.0) | 214 (8.4) | 231 (9.1) |

| Package | | | | |
|------------|----------------------------|---------------------|--------------------|---------------------|
| Frame Size | Gross weight [kg (lbs)] | Length [mm (in)] | Width [mm (in)] | Height [mm (in)] |
| Frame B | 310 (683) | 250 (9.8) | 200 (7.9) | 295 (11.6) |

3.3 Dimensions Frame C

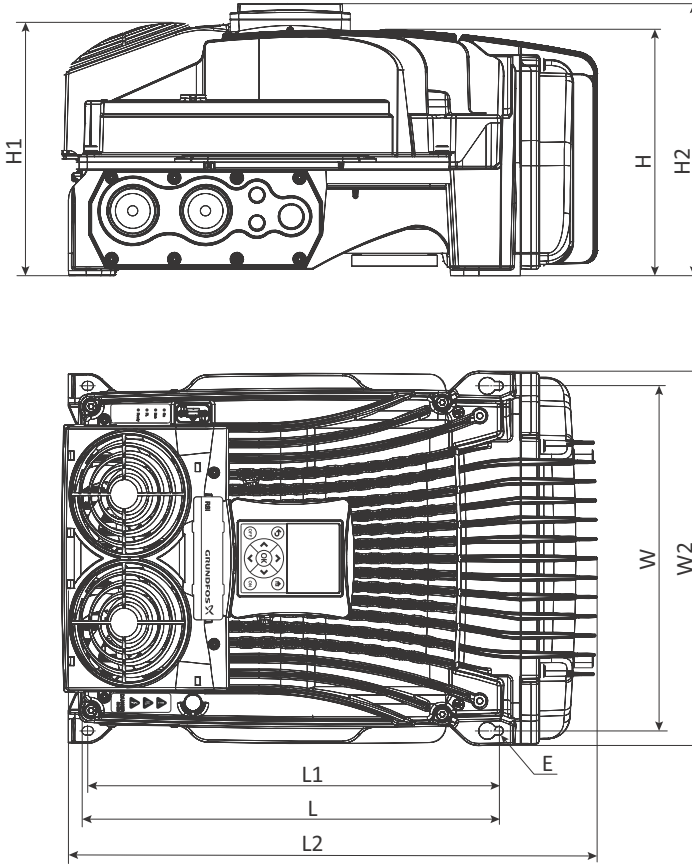

TM06 6528 1914

Fig. 11 Frame C 18,5 - 37 kW (25 - 50 hp)

| Product | | | | | | | | | | |
|------------|--------------------------|-------------------|-------------------|--------------------|-------------------|--------------------|--------------------|-------------------|--------------------|--------------------|
| Frame Size | Net weight [kg (lbs)] | E [mm (in)] | W [mm (in)] | W2 [mm (in)] | L [mm (in)] | L1 [mm (in)] | L2 [mm (in)] | H [mm (in)] | H1 [mm (in)] | H2 [mm (in)] |
| Frame C | 32 (69) | ∅8.2 (0.32) | 322 (12.7) | 350 (13.8) | 385 (15.2) | 382.5 (15.1) | 500 (19.7) | 230 (9.1) | 236 (9.3) | 254 (10) |

| Package | | | | |
|------------|----------------------------|---------------------|--------------------|---------------------|
| Frame Size | Gross weight [kg (lbs)] | Length [mm (in)] | Width [mm (in)] | Height [mm (in)] |
| Frame C | 310 (683) | 250 (9.8) | 200 (7.9) | 295 (11.6) |

3.4 Introduction of modules

The mechanical concept of Grundfos RSI drive is based on two segregated parts, power and control, connected to each other by pluggable terminals. The power unit, called powerhead, includes all the power electronics such as the EMC-filter, IGBTs, capacitors, choke or power boards while the control board and the control terminals are located in the terminal box.

3.5 Mounting

The drive consists of two main elements:

1. The terminal box that includes the power

terminals and control board with the control terminals and

2. The powerhead containing all the power electronics.

To install the drive, both parts need to be separated. The terminal box must be fixed first and all cabling done. After this, the powerhead will be plugged on the terminal box and fixed with 4 (Frame A and C) or 6 (Frame B) dedicated screws located on top side of the powerhead (see fig. 13). In order to guarantee specified IP protection, recommended fastening torque is 2-3 Nm. The screws should be tightened crosswise.

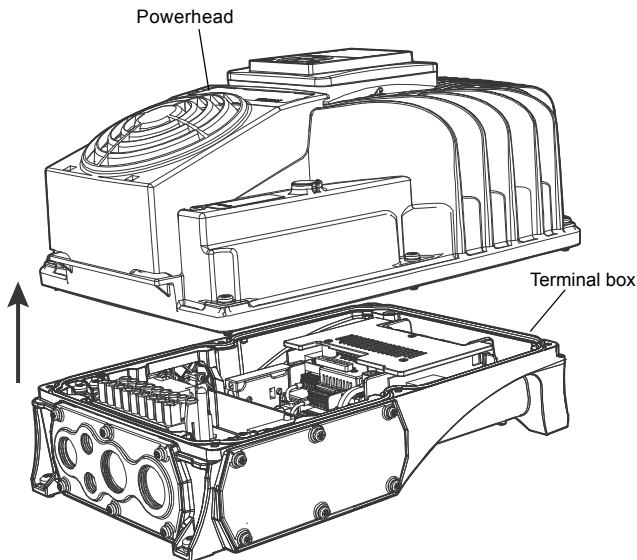

Fig. 12 Separation of modules(Frame B example).

3.5.1 Wall-mounting

The drive can be mounted in vertical or horizontal position on the wall or any other relatively even mounting plane or machine frame and fixed with the screws recommended in the table below

| Frame | Screw number | Screw size |
|-------|--------------|------------|
| A | 4 | M5 |
| B | 4 | M6 |
| C | 4 | M8 |

TM06 6529 1813

3.5.2 Motor-mounting

The drive can also be mounted on a motor (on top or on any side of the motor). The drive is equipped with a cooling system independent of the motor. Motor-mounting requires special adapting components. Contact your local Grundfos distributor for additional information.

3.5.3 Segregated modules

In order to ease replacements in case of failure, the power and the control sub-systems are enclosed in two segregated parts, connected together through pluggable terminals:

- Power-head: heat-sink enclosing all power electronics
- Terminal-box: block containing unit control and power terminals

Firstly, the terminal-box has to be fixed and the cabling has to be done. Secondly, the power-head has to be plugged and fixed to the terminal-box with dedicated screws (see the table below). In order to preserve the specified IP protection class, the recommended fastening torque is 2-3 Nm.

| Frame | Screw number | Screw size |
|-------|--------------|------------|
| A | 4 | M5 |
| B | 6 | M5 |
| C | 4 | M6 |

3.6 Cooling

The AC drive produces heat in operation and is cooled down by air circulated by a fan. The cooling concept is independent of the motor fan.

Enough free space shall be left around the AC drive to ensure sufficient air circulation and cooling. Different acts of maintenance may also require a certain amount of free space.

The minimum clearances given in the table [Min clearance](#) must not be exceeded. It is also important to ensure that the temperature of the cooling air does not exceed the maximum ambient temperature of the converter.

Contact local Grundfos distributor for more information on required clearances in different installations.

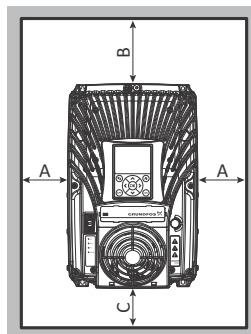

Fig. 13 Installation space

TM06 6529 1813

| Pos. | Description |
|------|---|
| A | Clearance left and right from the drive |
| B | Clearance above the drive |
| C | Clearance underneath the AC drive |

| Type | Min clearance [mm (in)] | | |
|-----------|-------------------------|-----------|----------|
| | A | B | C |
| All types | 80 (3.2) | 160 (6.3) | 60 (2.4) |

| Frame | Cooling air required [m ³ /h (GPM)] |
|-------|--|
| | A |
| B | 140 (616) |
| C | 280 (1233) |

Should you need further details on the cooling system of the Grundfos RSI, please contact your local Grundfos distributor.

4. Power cabling

The mains cables are connected to terminals L1, L2 and L3 and the motor cables to terminals marked with U, V and W. See principal connection diagram in fig. 15. See also [Cable types required to meet standards](#) for the cable recommendations for different EMC levels.

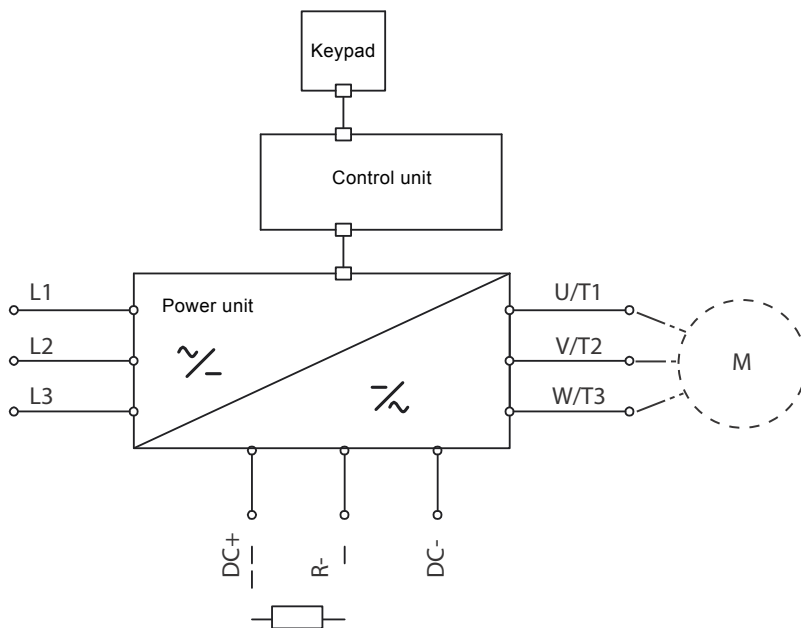

Fig. 14 Principal connection diagram

Use cables with heat resistance in accordance with the application requirements. The cables and the fuses must be dimensioned according to the AC drive nominal OUTPUT current which you can find on the rating plate.

TM06 7137 2916

Cable types required to meet standards

| Cable type | EMC levels | | |
|---------------|-----------------------------|-----------------------------|-------------|
| | 1 st environment | 2 nd environment | |
| | Category C2 | Category C3 | Category C4 |
| Mains cable | 1 | 1 | 1 |
| Motor cable | 3* | 2 | 2 |
| Control cable | 4 | 4 | 4 |

- 1 = Power cable intended for fixed installation and the specific mains voltage. Shielded cable not required. (MCMK or similar recommended).
- 2 = Symmetrical power cable equipped with concentric protection wire and intended for the specific mains voltage. (MCMK or similar recommended). See fig. 16.
- 3 = Symmetrical power cable equipped with compact low-impedance shield and intended for the specific mains voltage. [MCCMK, EMCMK or similar recommended; Recommended cable transfer impedance (1...30MHz) max. 100 mOhm/m]. See fig. 16.
*360 ° earthing of the shield with cable glands in motor end needed for EMC level C2.
- 4 = Screened cable equipped with compact low-impedance shield (JAMAK, SAB/ÖZCuY-O or similar).

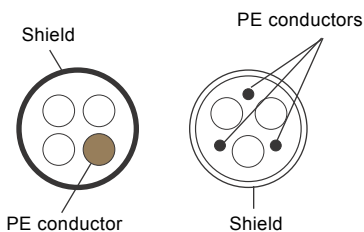

Fig. 15

TM06 6969 2916

Note The EMC requirements are fulfilled at factory defaults of switching frequencies (all frames).

Note If safety switch is connected the EMC protection shall be continuous over the whole cable installation.

4.1 Circuit breaker

Please disconnect the drive via an external circuit breaker. You have to provide a switching device between supply and main connection terminals. When connecting the input terminals to the power supply using a circuit breaker, observe that this is of type B or type C and ensure it has a capacity of 1.5 to 2 times of the inverter's rated current (see [7.1.1 Mains voltage 3 AC 208-240 V](#) and [7.1.2 Mains voltage 3 AC 380-480/500 V](#)).

Note Circuit breaker is not allowed in installations where C-UL is required. Only fuses are recommended.

4.2 UL standards on cabling

To meet the UL (Underwriters Laboratories) regulations, use a UL-approved copper cable with a minimum heat-resistance of +70/75°C (158/167 °F). Use Class 1 wire only.

The units are suitable for use on a circuit capable of delivering not more than 100,000 rms symmetrical amperes, 600V AC maximum, when protected by T or J class fuses.

Warning
Integral solid state short circuit protection does not provide branch circuit protection. Branch circuit protection must be provided in accordance with the National Electrical Code and any additional local codes.



4.3 Description of the terminals

The following pictures describe the power terminals and the typical connections in Grundfos RSI drives.

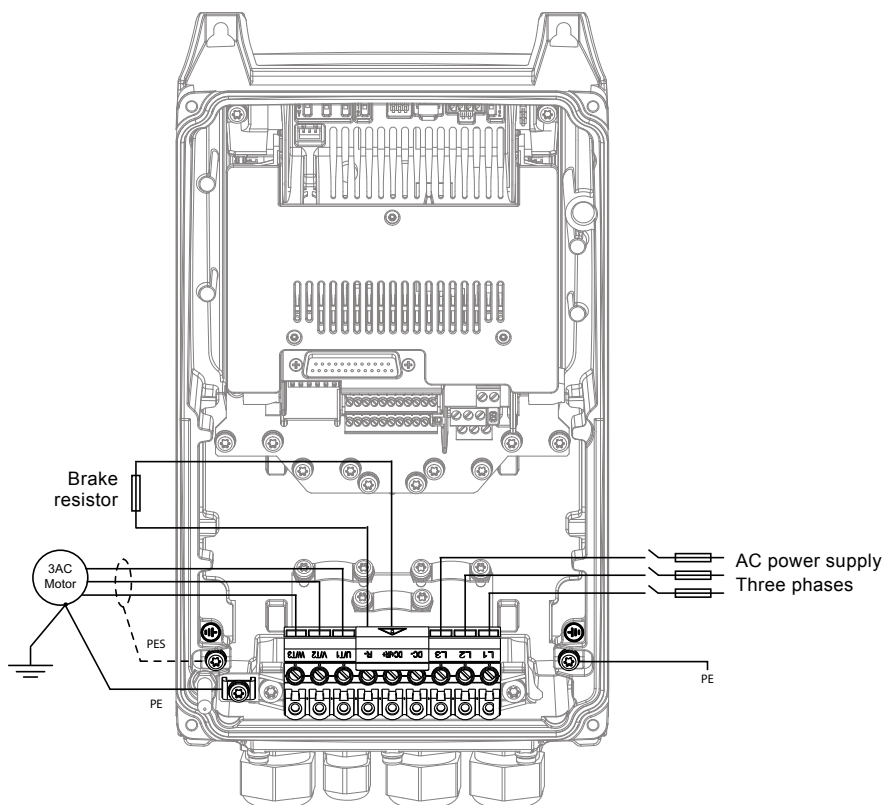

TM06 7022 2916

Fig. 16 Power connections, Frame A

| Terminal | Description |
|----------------------|---|
| L1 L2 L3 | These terminals are the input connections for the power supply. |
| DC- DC+/R+ R- | DC bus terminals (DC- DC+) and Brake resistor terminals (R+ R-) |
| U/T1 V/T2 W/T3 | These terminals are for motor connections. |

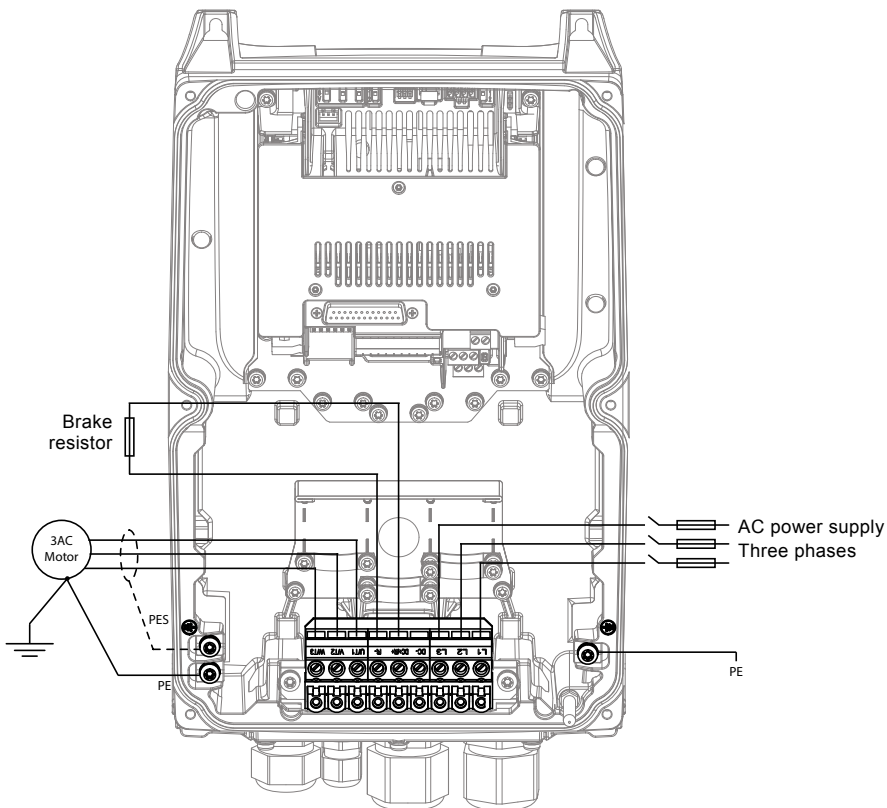
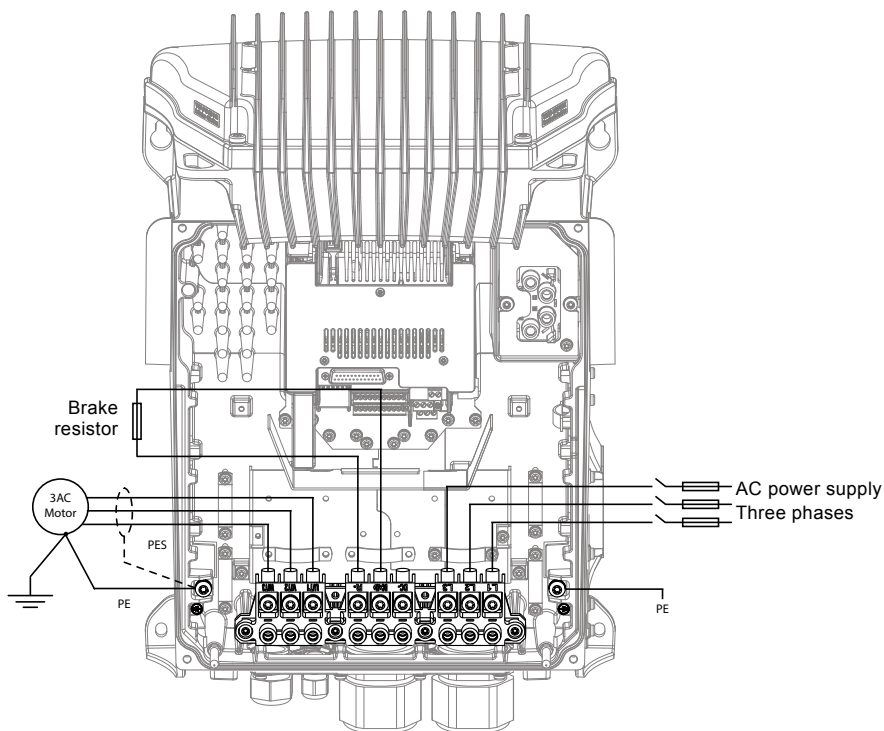

Fig. 17 Power connections, Frame B

| Terminal | Description |
|----------------------|---|
| L1 L2 L3 | These terminals are the input connections for the power supply. |
| DC- DC+/R+ R- | DC bus terminals (DC- DC+) and Brake resistor terminals (R+ R-) |
| U/T1 V/T2 W/T3 | These terminals are for motor connections. |

TM06 7025 2916



TM06 7028 2916

Fig. 18 Power connections, Frame C

| Terminal | Description |
|----------------------|---|
| L1 L2 L3 | These terminals are the input connections for the power supply. |
| DC- DC+/R+ R- | DC bus terminals (DC- DC+) and Brake resistor terminals (R+ R-) |
| U/T1 V/T2 W/T3 | These terminals are for motor connections. |

4.4 Cable dimensioning and selection

The tables in section [4.4.1 Cable and fuse sizes, frames MM4 to MM6](#) and [4.4.2 Cable and fuse sizes, frames MM4A to MM6C, North America](#) show the minimum dimensions of the Cu-cables and the corresponding fuse sizes.

These instructions apply only to cases with one motor and one cable connection from the AC drive to the motor. In any other case, ask the factory for more information.

4.4.1 Cable and fuse sizes, frames A to C

The recommended fuse type is gG/gL (IEC 60269-1). The fuse voltage rating should be selected according to the supply network. The final selection should be made according to local regulations, cable installation conditions and cable specification. Bigger fuses than those recommended below shall not be used.

Check that the fuse operating time is less than 0.4 seconds. Operating time depends on used fuse type and impedance of the supply circuit. Consult the factory about faster fuses. Grundfos also recommends high speed gS (IEC 60269-4) fuse ranges.

Cable and fuse sizes for Grundfos RSI

| Frame | Type | I _{INPUT} [A] | Fuse (gG/gL) [A] | Mains and motor cable Cu [mm ²] | Terminal cable size | |
|-------|---|--------------------------|------------------|---|------------------------------------|-----------------------------------|
| | | | | | Main terminal [mm ²] | Earth terminal [mm ²] |
| A | 0003 4 - 0004 4 0003 5 - 0004 5 | 3.4 - 4.6 | 6 | 3*1.5+1.5 | 0.5 - 10 solid 0.5 - 6 stranded | M4 ring terminal or 1-6 |
| | 0007 2 - 0008 2 0005 4 - 0008 4 0005 5 - 0008 5 | 6.0 - 7.2 5.4 - 8.1 | 10 | 3*1.5+1.5 | 0.5 - 10 solid 0.5 - 6 stranded | M4 ring terminal or 1-6 |
| | 0011 2 - 0012 2 0009 4 - 0012 4 0009 5 - 0012 5 | 9.7 - 10.9 9.3 - 11.3 | 16 | 3*2.5+2.5 | 0.5 - 10 solid 0.5 - 6 stranded | M4 ring terminal or 1-6 |
| B | 0018 2 0016 4 0016 5 | 16.1 15.4 | 20 | 3*6+6 | 0.5 - 16 solid or stranded | M5 ring terminal or 1-10 |
| | 0024 2 0023 4 0023 5 | 21.7 21.3 | 25 | 3*6+6 | 0.5 - 16 solid or stranded | M5 ring terminal or 1-10 |
| | 0031 2 0031 4 0031 5 | 27.7 28.4 | 32 | 3*10+10 | 0.5 - 16 solid or stranded | M5 ring terminal or 1-10 |
| C | 0038 4 0038 5 | 36.7 | 40 | 3*10+10 | M6 ring terminal | M6 ring terminal |
| | 0048 2 0046 4 0046 5 | 43.8 43.6 | 50 | 3*16+16 | M6 ring terminal | M6 ring terminal |
| | 0062 2 0061 4 0061 5 | 57.0 58.2 | 63 | 3*25+16 | M6 ring terminal | M6 ring terminal |
| | 0072 4 0072 5 | 67.5 | 80 | 3*35+16 | M6 ring terminal | M6 ring terminal |

The terminal sizes are intended for 1 conductor. For MM6, the max. diameter of the ring terminal is 14 mm. The cable dimensioning is based on the criteria of the International Standard IEC60364-5-52: Cables must be PVC-isolated; Max number of parallel cables is 9.

When using cables in parallel, Note however that the requirements of both the cross-sectional area and the max number of cables must be observed.

For important information on the requirements of the earthing conductor, see section [1.4 Earthing and earth fault protection](#) of the standard.

For the correction factors for each temperature, see International Standard IEC60364-5-52.

4.4.2 Cable and fuse sizes, frames A to C, North America

The recommended fuse type is class T (UL & CSA). The fuse voltage rating should be selected according to the supply network. The final selection should be made according to local regulations, cable installation conditions and cable specification. Bigger fuses than those recommended below shall not be used.

Check that the fuse operating time is less than 0.4 seconds. Operating time depends on used fuse type and impedance of the supply circuit. Consult the factory about faster fuses. Grundfos also recommends high speed J (UL & CSA) fuse ranges.

Cable and fuse sizes for Grundfos RSI

| Frame | Type | I _{INPUT} [A] | Fuse (class T) [A] | Mains and motor cable Cu | Terminal cable size | |
|-------|---|---------------------------|--------------------------|--------------------------------|-----------------------------------|---------------------------------|
| | | | | | Main terminal | Earth terminal |
| A | 0003 4 - 0004 4 0003 5 - 0004 5 | 3.4 - 4.6 | 6 | AWG14 | AWG24-AWG10 | AWG17-AWG10 M4 ring terminal |
| | 0007 2 - 0008 2 0005 4 - 0008 4 0005 5 - 0008 5 | 6.0 - 7.2 5.4 - 8.1 | 10 | AWG14 | AWG24-AWG10 | AWG17-AWG10 M4 ring terminal |
| | 0011 2 0009 4 0009 5 | 9.7 9.3 | 15 | AWG14 | AWG24-AWG10 | AWG17-AWG10 M4 ring terminal |
| | 0012 2 0012 4 0012 5 | 10.9 11.3 | 20 | AWG14 | AWG24-AWG10 | AWG17-AWG10 M4 ring terminal |
| | 0018 2 0016 4 0016 5 | 16.1 15.4 | 25 | AWG10 | AWG20-AWG5 | AWG17-AWG8 M5 ring terminal |
| | 0024 2 0023 4 0023 5 | 21.7 21.3 | 30 | AWG10 | AWG20-AWG5 | AWG17-AWG8 M5 ring terminal |
| B | 0031 2 0031 4 0031 5 | 27.7 28.4 | 40 | AWG8 | AWG20-AWG5 | AWG17-AWG8 M5 ring terminal |
| | 0038 4 0038 5 | 36.7 | 50 | AWG4 | AWG13-AWG0 M6 ring terminal | AWG13-AWG2 M6 ring terminal |
| | 0048 2 0046 4 0046 5 | 43.8 43.6 | 60 | AWG4 | AWG13-AWG0 M6 ring terminal | AWG13-AWG2 M6 ring terminal |
| | 0062 2 0061 4 0061 5 | 57.0 58.2 | 80 | AWG4 | AWG13-AWG0 M6 ring terminal | AWG13-AWG2 M6 ring terminal |
| | 0072 4 0072 5 | 67.5 | 100 | AWG2 | AWG9-AWG2/0 M6 ring terminal | AWG9-AWG2/0 M6 ring terminal |
| | C | | | | | |
| | | | | | | |
| | | | | | | |
| | | | | | | |
| | | | | | | |
| | | | | | | |

The cable dimensioning is based on the criteria of the Underwriters' Laboratories UL508C: Cables must be PVC-isolated; Max ambient temperature +40 °C (104 °F), max temperature of cable surface +70/+75 °C (158/167 °F); Use only cables with concentric copper shield; Max number of parallel cables is 9.

When using cables in parallel, NOTE HOWEVER that the requirements of both the cross-sectional area and the max number of cables must be observed.

For important information on the requirements of the earthing conductor, see standard Underwriters' Laboratories UL508C.

For the correction factors for each temperature, see the instructions of standard Underwriters' Laboratories UL508C.

4.4.3 Brake resistor cables

Grundfos RSI AC drives are equipped with terminals for an optional external brake resistor. These terminals are marked with DC+/R+ and R-. See the tables in section 7.2 Brake resistor ratings for the resistor ratings.

4.4.4 Control cables

For information on control cables see section 5. Control unit.

4.5 Cable installation

- Before starting, check that none of the components of the AC drive is live. Read carefully the warnings in section 1. Symbols used in this document.
- Place the motor cables sufficiently far from other cables
- Avoid placing the motor cables in long parallel lines with other cables.
- If the motor cables run in parallel with other cables note the minimum distances between the motor cables and other cables given in table below.

| Distance between cables [m (ft)] | Shielded cable [m (ft)] |
|----------------------------------|-------------------------|
| 0.3 (1) | ≤ 50 (164) |
| 1.0 (3.3) | ≤ 200 (656) |

- The given distances also apply between the motor cables and signal cables of other systems.
- The maximum lengths of motor cables (shielded) are 100 m (Frame A) and 150 m (Frame B and C).
- The motor cables should cross other cables at an angle of 90 degrees.
- If cable insulation checks are needed, see section 6.3.1 Cable and motor insulation checks.

Start the cable installation according to the instructions below:

1. Strip the motor and mains cables as recommended below.

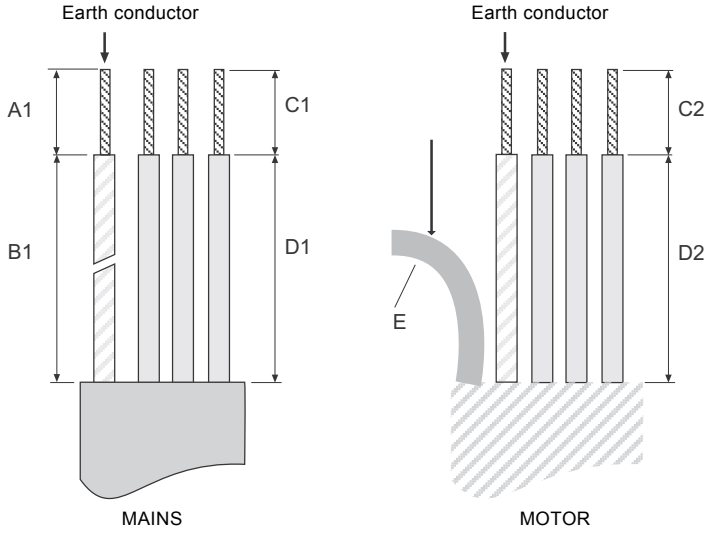

Fig. 19 Stripping of cable

4.5.1 Cables stripping lengths

| Frame | A1 [mm (in)] | B1 [mm (in)] | C1 [mm (in)] | D1 [mm (in)] | C2 [mm (in)] | D2 [mm (in)] | E |
|-------|--------------|--------------|--------------|--------------|--------------|--------------|----------------------|
| A | 15 (0.6) | 70 (2.8) | 10 (0.4) | 30 (1.2) | 7 (0.3) | 30 (1.2) | as short as possible |
| B | 20 (0.8) | 70 (2.8) | 10 (0.4) | 40 (1.6) | 10 (0.4) | 40 (1.6) | |
| C | 20 (0.8) | 90 (3.5) | 15 (0.6) | 60 (2.4) | 15 (0.6) | 60 (2.4) | |

TMM06 7009 2916

IEC installation:

- 2. Remove the cable entry plate. The cable entry system is a combination of a cable entry plate (see the figure below) and cable glands. In the cable entry plate there are several openings available for the cables with ISO metric thread. Open only the inlet holes where you need to run the cables.
- 3. Choose the correct cable glands according to drive and cable size as shown in the following pictures.

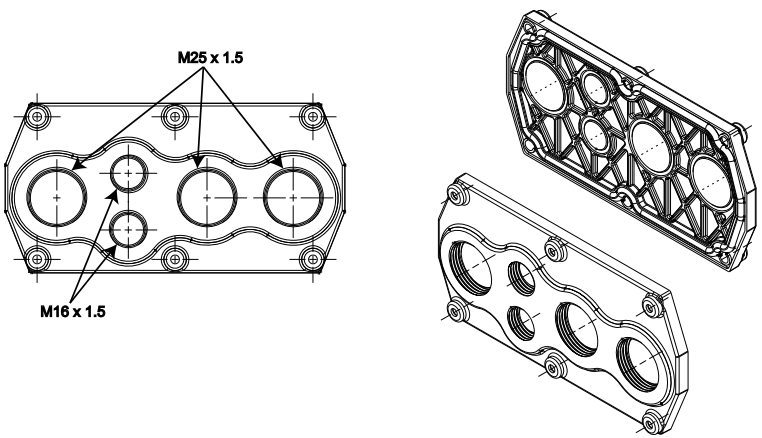

Fig. 20 Cable entry plate, Frame A

TM06 7023 2916

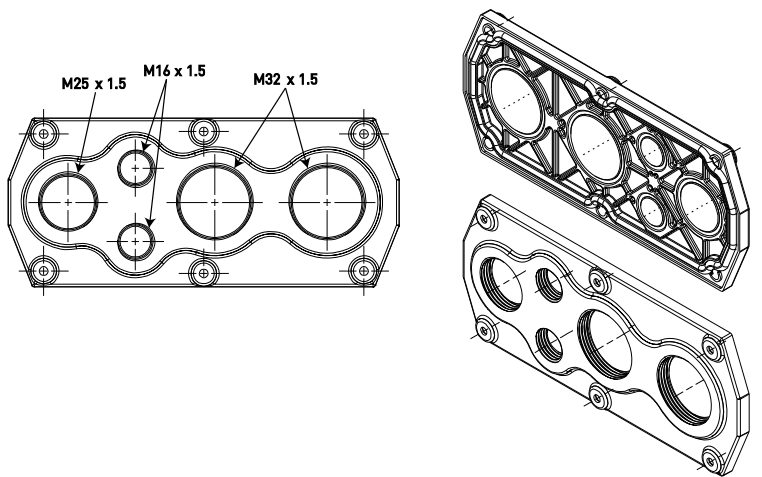
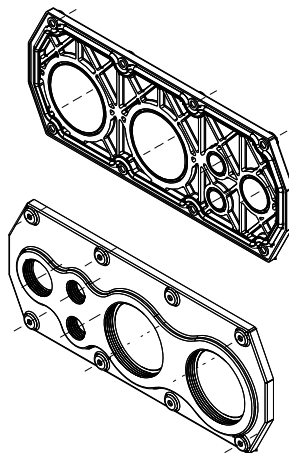
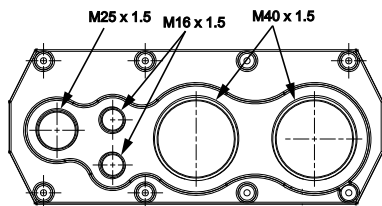

Fig. 21 Cable entry plate, Frame B

TM06 7160 2916



TM06 7030 2916

Fig. 22 Cable entry plate, Frame C

4. Cable glands must be made of plastic materials. They are used for sealing cables passing through cable entries to ensure the characteristics of the enclosure.

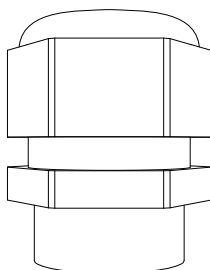

Fig. 23 Cable gland.

TM06 6968 2916



Plastic cable glands are recommend. If metal cable glands are needed, all insulation system requirements and all protective earthing requirements have to be fulfilled in accordance with the national electrical regulations and IEC 61800-5-1.

5. Screw the cable glands on the cable entry holes using the proper tightening torque as shown in the following table.

Tightening torque and dimension of cable glands

| Frame | Gland screw type [metric] | Tightening torque [Nm]/[lb-in.] | |
|-------|---------------------------|---------------------------------|--------|
| | | [Nm] | lb-in. |
| A | M16 | 1.0 | 8.9 |
| | M25 | 4.0 | 35.5 |
| B | M16 | 1.0 | 8.9 |
| | M25 | 4.0 | 35.5 |
| | M32 | 7.0 | 62.1 |
| C | M16 | 1.0 | 8.9 |
| | M25 | 4.0 | 35.5 |
| | M40 | 10.0 | 88.7 |

UL installation:

- To connect NPT pipes to GrundfosRSI, use the optional metal cable entry plate (included in -R02 option) to meet UL installation rules.

One metal conduit plate with accessories (screws and gasket) is delivered in a separate bag together with the drive. See the following figures for more details.

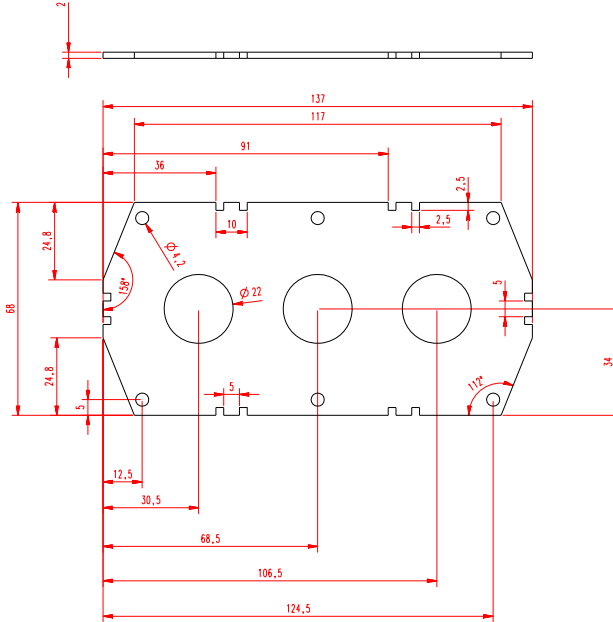
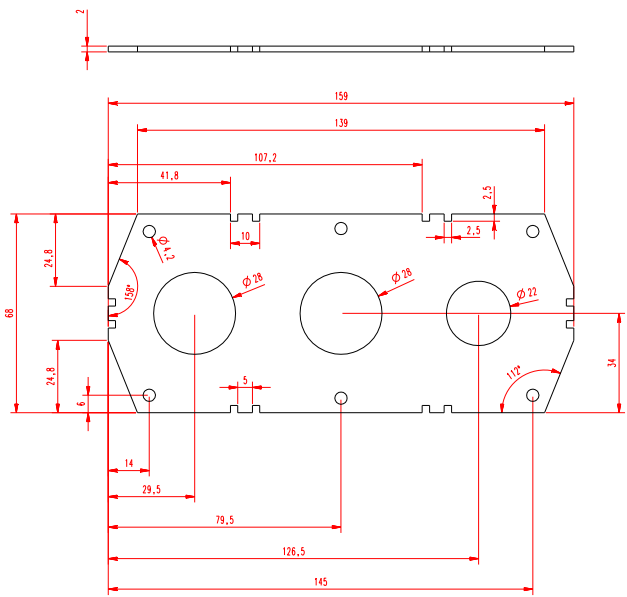

Fig. 24 Cable entry plate, Frame A UL installation

TM06 6954 2916



TM06 6955 2916

Fig. 25 Cable entry plate, Frame B UL installation

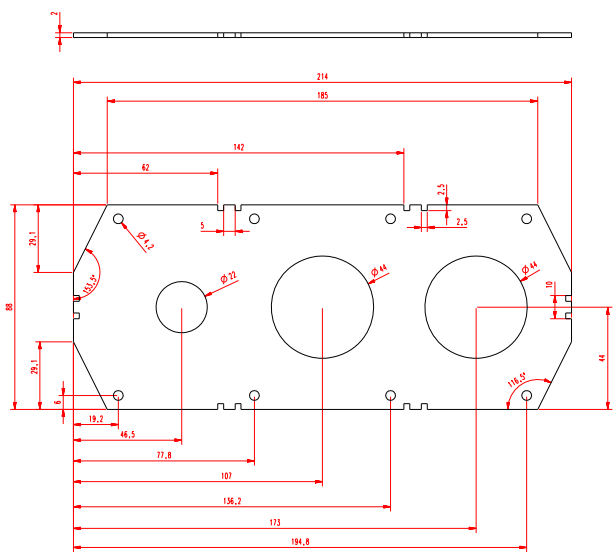

TM06 6956 2916

Fig. 26 Cable entry plate, Frame C UL installation

7. All the (3) terminal box openings are closed with the standard plastic plates with the metric threads.
8. The metal cable entry plate for UL installation has to be installed in place of one of standard plastic cable entries provided with the default package. The metal cable entry plate has three not-threaded openings: input line, motor and I/Os and can be mounted only on left or right-hand side of the drive.
9. Flexible or rigid cable conduit can be used.
Use proper fittings to join and terminate rigid conduit tubing, and protect it from damage too.
The proper selection of electrical conduit materials, fittings, and installation are important for safe electrical wiring.
10. Setscrew fittings are commonly used with conduit; they provide weather tight joints that are firm to keep the IP degree of the drive.

Cable installation:

11. Pass the cables (supply cable, motor cable, brake cable and I/O cables) through the conduits (UL connections) or through the cable glands (IEC connections) and cable entries.
12. Detach the cable clamps and the grounding clamps.
13. Expose the shield of both cables in order to make a 360-degree connection with the cable clamp (reverse the shield over the plastic cover of the cable and fix all together).
Connect the phase conductors of the supply and motor cables into their respective terminals.
Form the rest of the cable shield of both cables into "pigtails" and make a grounding connection with the clamp. Make the pigtails just long enough to reach and be fixed to the terminal - no longer.

Tightening torques of cable terminals:

| Frame | Type | Tightening torque [Nm]/[lb-in.] Power and motor terminals | | Tightening torque [Nm]/[lb-in.] EMC grounding clamps | | Tightening torque, [Nm]/ [lb-in.] Grounding terminals | |
|-------|-----------------|--|-------------|---|--------|---|--------|
| | | [Nm] | lb-in. | [Nm] | lb-in. | [Nm] | lb-in. |
| A | 0007 2 - 0012 2 | 1.2 - 1.5 | 10.6 - 13.3 | 1.5 | 13.3 | 2.0 | 17.7 |
| | 0003 4 - 0012 4 | | | | | | |
| | 0003 5 - 0012 5 | | | | | | |
| B | 0018 2 - 0031 2 | 1.2 - 1.5 | 10.6 - 13.3 | 1.5 | 13.3 | 2.0 | 17.7 |
| | 0016 4 - 0031 4 | | | | | | |
| | 0016 5 - 0031 5 | | | | | | |
| C | 0048 2 - 0062 2 | 4-5 | 35.4 - 44.3 | 1.5 | 13.3 | 2.0 | 17.7 |
| | 0038 4 - 0072 4 | | | | | | |
| | 0038 5 - 0072 5 | | | | | | |

14. Check the connection of the earth cable to the motor and the AC drive terminals marked with



5. Control unit

Remove the powerhead of the drive to reveal the terminal box with the control terminals.

The control unit of the AC drive consists of the control board and additional boards (option boards) connected to the slot connectors of the control board. The locations of boards, terminals and switches are presented in fig. 28 below.

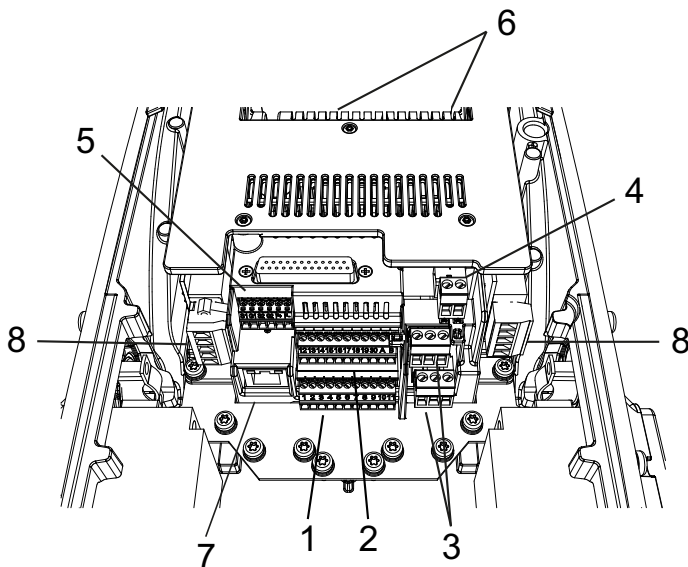

Fig. 27 Locations of components in control unit

Locations of components in control unit

| Pos. | Meaning |
|------|--|
| 1 | Control terminals 1-11 (see 5.1.2 Standard I/O terminals) |
| 2 | Control terminals 12-30, A-B (see 5.1.2 Standard I/O terminals) |
| 3 | Relay terminals (see 5.1.2 Standard I/O terminals) |
| 4 | Thermistor input (see 5.1.2 Standard I/O terminals) |
| 5 | STO terminals |
| 6 | Dip switches |
| 7 | Ethernet terminal (see 5.2.1 Prepare for use through Ethernet) |
| 8 | Option boards |

When delivered from the factory, the control unit of the AC drive contains the standard controlling interface - the control and relay terminals of the control unit - unless otherwise specifically ordered. On the next pages you will find the arrangement of the control I/O and the relay terminals, the general wiring diagram and the control signal descriptions.

The control board can be powered externally (+24 VDC, max. 1000 mA, $\pm 10\%$) by connecting the external power source to terminal #30, see section [5.1.2 Standard I/O terminals](#). This voltage is sufficient for parameter setting and for keeping the control unit active. Note however that the measurements of the main circuit (e.g. DC-link voltage, unit temperature) are not available when the mains is not connected.

TM06 6970 2916

5.1 Control unit cabling

The principal terminal block placement is presented in fig. 29 below. The control board is equipped with 22 fixed control I/O terminals and the relay board with 6+2. Additionally, the terminals for the Safe Torque Off (STO) function (see section 9. *Safe Torque Off*) can be seen in the picture below. All signal descriptions are also given in section 5.1.2 *Standard I/O terminals*.

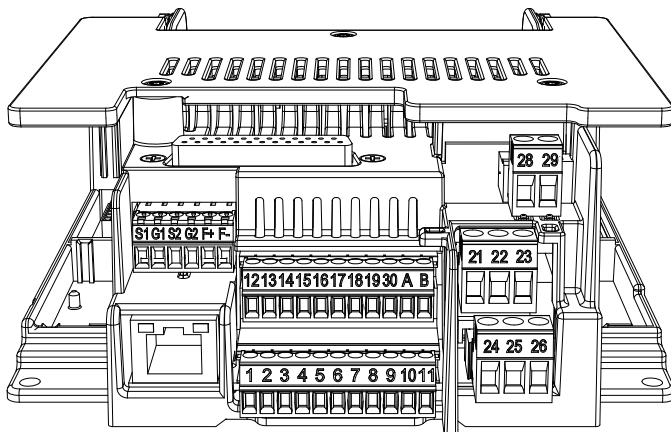

Fig. 28 Control terminals

5.1.1 Control cable sizing

The control cables shall be at least 0.5 mm^2 screened multicore cables, see the following table. The maximum terminal wire size is 2.5 mm^2 for the relay terminals and 1.5 mm^2 for other terminals.

Find the tightening torques of the control and relay board terminals in the following table.

| Terminal screw | Tightening torque | |
|--|-------------------|----------|
| | [Nm] | [lb-in.] |
| I/O terminals and STO terminals (screw M2) | 0.5 | 4.5 |
| Relay terminals (screw M3) | 0.5 | 4.5 |

TM06 6976 2916

5.1.2 Standard I/O terminals

The terminals of the Standard I/Os and the Relays are described below. For more information on the connections, see section 7. *Technical data*.

The terminals shown on shadowed background are assigned for signals with optional functions selectable with DIP switches. See more information in 5.1.5 and in 5.1.6.

Control I/O terminal signals and connection example

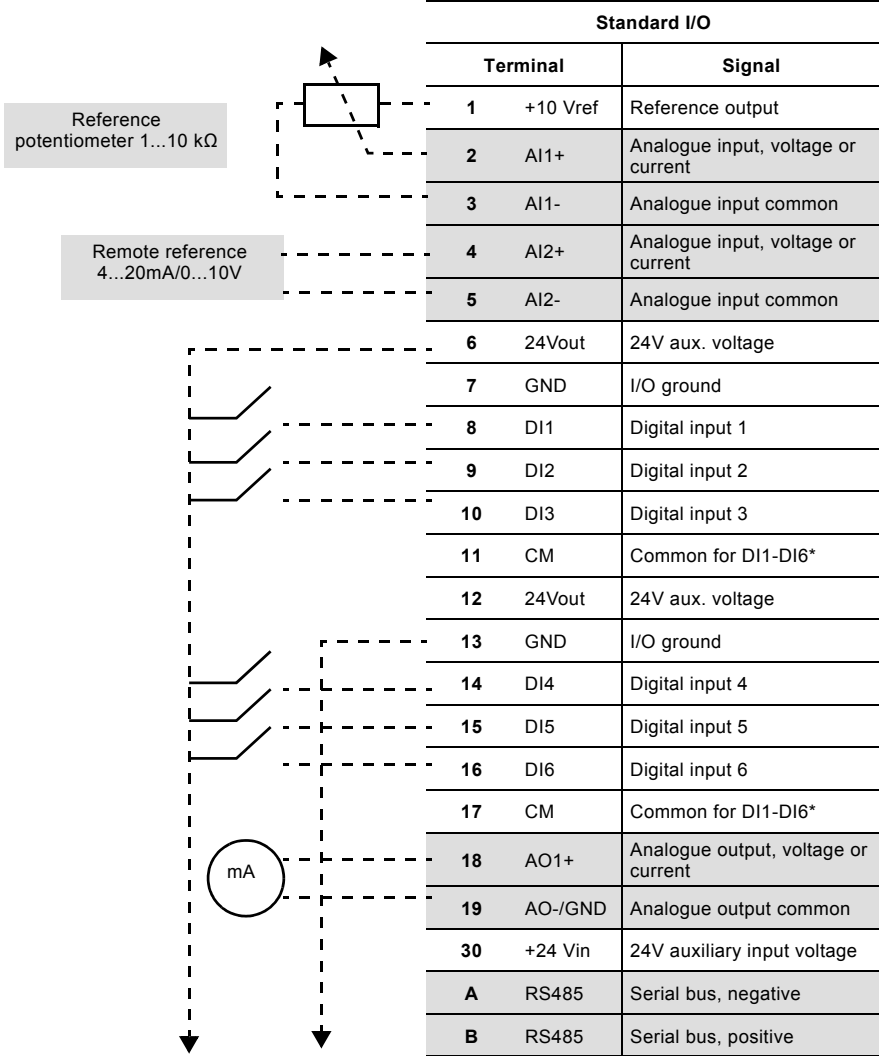

* Can be isolated from ground, see section 5.1.6 *Isolating digital inputs from ground*.

5.1.3 Relay and thermistor input terminals

I/O terminal signals for relay and thermistor terminals and connection example.

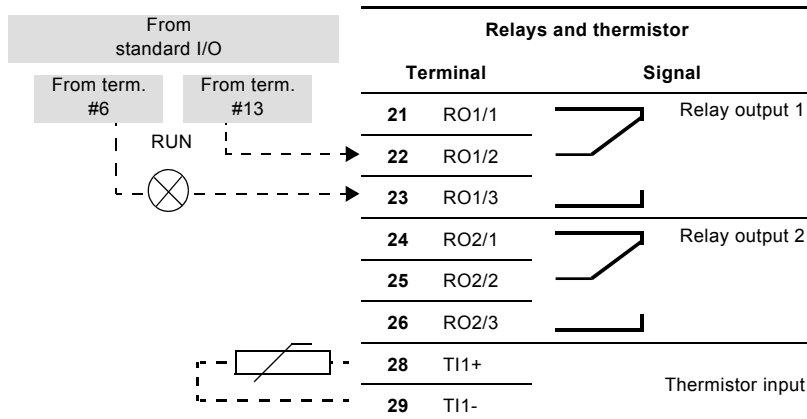

5.1.4 Safe Torque off (STO) terminals

For more information on the functionalities of the Safe Torque Off (STO), see section 9. [Safe Torque Off](#).

I/O terminal signals for the STO functions.

Safe Torque Off terminals

| Terminal | Signal |
|----------|--|
| S1 | Isolated digital input 1 (interchangeable polarity); +24 V ± 20 % 10 ... 15 mA |
| G1 | |
| S2 | Isolated digital input 2 (interchangeable polarity); +24 V ± 20 % 10 ... 15 mA |
| G2 | |
| F+ | Isolated feedback (CAUTION! Polarity to be respected); +24 V ± 20 % |
| F- | Isolated feedback (CAUTION! Polarity to be respected); GND |

5.1.5 Selection of terminal functions with dip switches

The Grundfos RSI drive embodies five so-called dip switches that allow for three functional selections each. The shadowed terminals in the table of section [5.1.2 Standard I/O terminals](#) can be functionally modified with the dip switches. The switches have three positions: C, 0 and V. The switch in the position "C" means that the input or the output has been set in current mode. The switch in the position "V" means voltage mode. The middle position "0" is for Test mode. See fig. 30 to locate the switches and make appropriate selections for your requirements. Factory defaults are: AI1 = V; AI2 = C, AO = C.

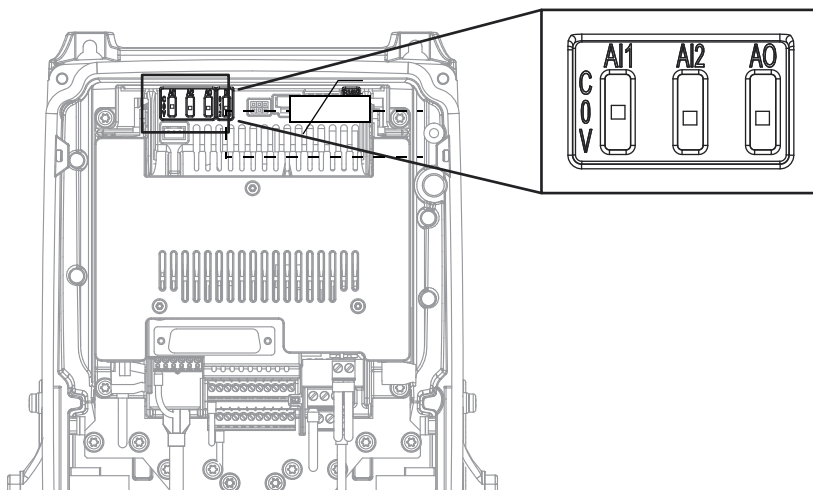

Fig. 29 Dip switches for analogue inputs and analogue output

TM06 6966 2916

5.1.6 Isolating digital inputs from ground

The digital inputs (terminals 8-10 and 14-16) on the standard I/O board can be isolated from ground by setting the dip switch to position '0'. The switch in the position "1" means that the common of digital input has been connected to 24 V (negative logic). The switch in the position "2" means that the common of digital inputs has been connected to ground (positive logic). See fig. 31. Locate the switch and set it in desired position. Factory default is 2.

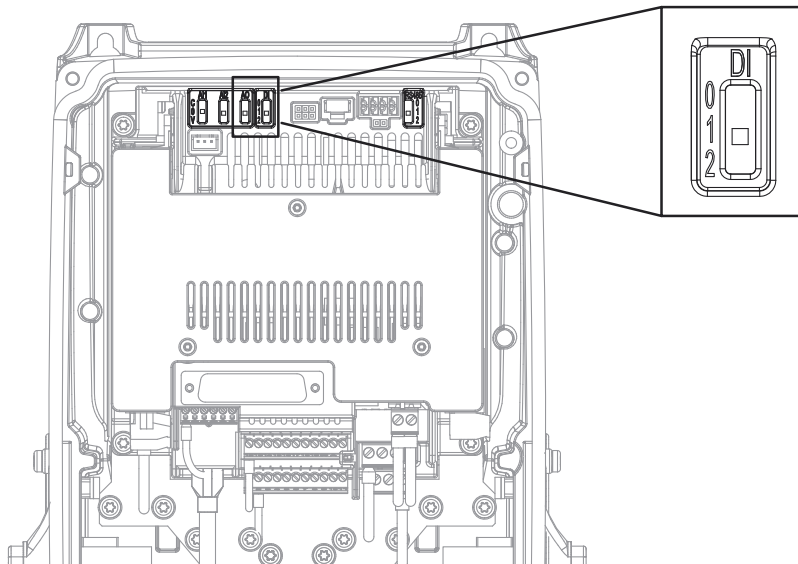

Fig. 30 Digital inputs dip switch

TN06 7142 2916

5.1.7 Bus termination of the RS485 connection

This dip switch is related to the RS485 connection. It's used for bus termination. The bus termination must be set to the first and to the last device on the network. This switch in position "0" means that a termination resistor of 120 ohm is connected and the termination of the bus has been set. This switch in the position "1" means that a pull-up and a pull-down resistors of 10 kOhm have been connected for biasing purpose. The switch in the position "2" means no termination and no biasing resistors have been connected. Factory default is 2. See fig. 32.

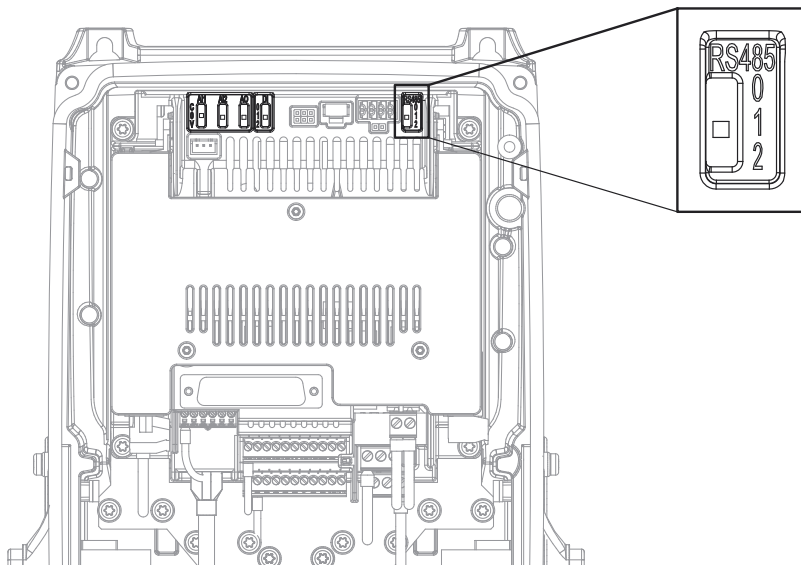

Fig. 31 RS485 dip switch

5.2 I/O cabling and Fieldbus connection

The AC drive can be connected to fieldbus either through RS485 or Ethernet. The connection for RS485 is on the standard I/O terminals (A and B) and the connection for Ethernet is left to the control terminals. See fig. 33.

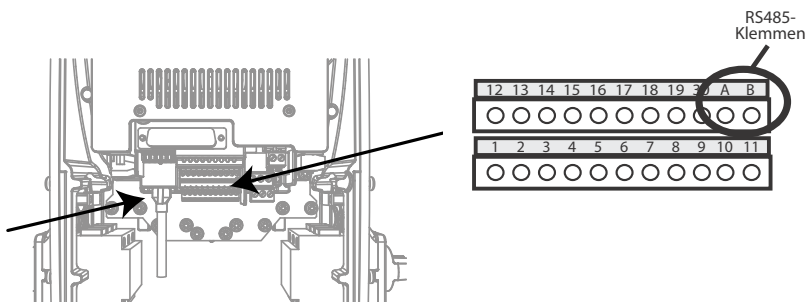

Fig. 32

TM06 6979 2916

TM06 6987 2916 - TM06 7141 2916

5.2.1 Prepare for use through Ethernet

1. Connect the Ethernet cable (see specification on page 42) to its terminal and run the cable through the conduit plate.
2. Remount the powerhead. note: When planning the cable runs, remember to keep the distance between the Ethernet cable and the motor cable at a minimum of 30 cm.

For more detailed information, see the user's manual of the fieldbus you are using.

Ethernet cable data

| | |
|--------------|--|
| Connector | Shielded RJ45 connector. Note: max length of the connector 40 mm (1.6 in). |
| Cable type | CAT5e STP |
| Cable length | Max. 100m(328 ft) |

5.2.2 Prepare for use through RS485

1. Strip about 15 mm of the RS485 cable (see specification on page 43) and cut off the grey cable shield. Remember to do this for both bus cables (except for the last device). Leave no more than 10 mm (0.4in) of the cable outside the terminal block and strip the cables at about 5 mm to fit in the terminals. See picture below.

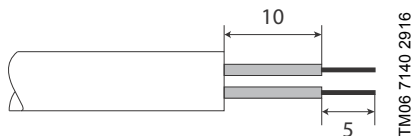

Also strip the cable now at such a distance from the terminal that you can fix it to the frame with the grounding clamp. Strip the cable at a maximum length of 15 mm (0.6 in). Do not strip the aluminum cable shield!

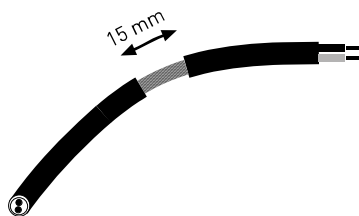

2. Then connect the cable to its appropriate terminals on Grundfos RSI AC drive standard terminal block, terminals *A* and *B* (*A* = negative, *B* = positive). See fig. 33.
3. Using the cable clamp included in the delivery of the drive, ground the shield of the RS485 cable to the frame of the AC drive.
4. If Grundfos RSI AC drive is the last device on the bus, the bus termination must be set. Locate the DIP switches to the top of the control unit (see fig. 30) and turn the right most switch to position "1". Biasing is built in the termination resistor. See also step 6.

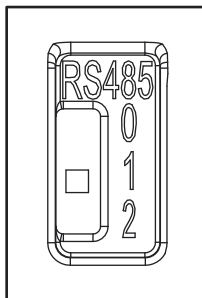

5. **Note:** When planning the cable runs, remember to keep the distance between the fieldbus cable and the motor cable at a minimum of 30 cm (11.8 in).

TM06 7143 2916

6. The bus termination must be set for the first and the last device of the fieldbus line. See picture below and step 4. We recommend that the first device on the bus and, thus, terminated, was the Master device.

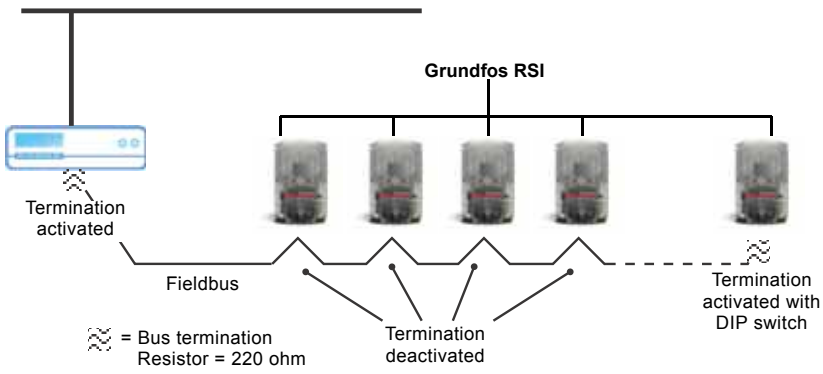

5.2.3 RS485 cable data

| | |
|--------------|--|
| Connector | 2.5 mm ² |
| Cable type | STP (Shielded Twisted Pair), type Belden 9841 or similar |
| Cable length | Depends on the used fieldbus. See respective bus manual. |

TM06 6967 2316

5.3 Battery installation for Real Time Clock (RTC)

Enabling the functions of the Real Time Clock (RTC) requires that an optional battery is installed in the Grundfos RSI drive.

Detailed information on the functions of the Real Time Clock (RTC) can be found in the Application Manual. See the following figures to install the battery on the control box of Grundfos RSI frequency converter.

1. Remove the three screws on the control box as shown in fig. 34.

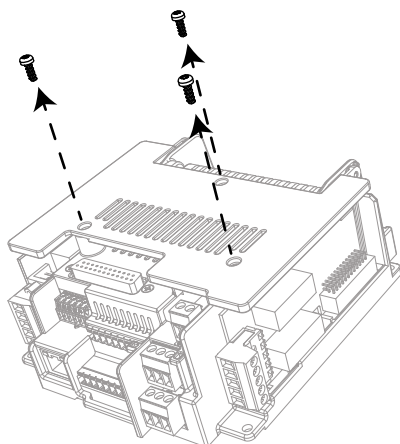

Fig. 33 Remove the three screws on the control box

TM06 6971 2916

2. Rotate and open the cover of the control box as shown in fig. 35.

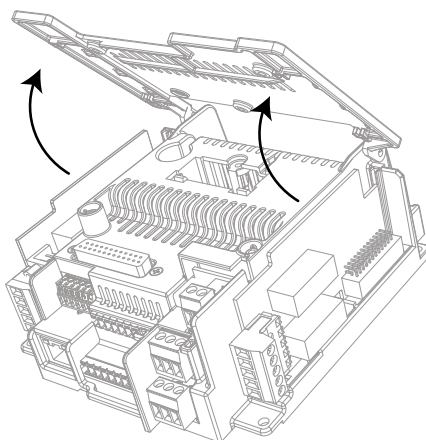

Fig. 34 Open the cover of control box

TM06 6972 2916

3. Install the battery in the correct place and connect it to the control box. See fig. 36 for battery location and connector.

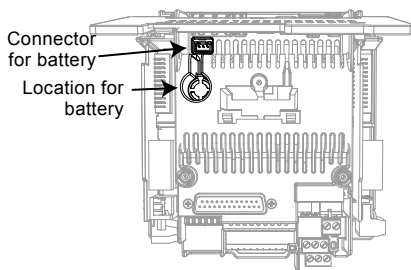

Fig. 35 Location and connector for the battery on the control box

TM06 6973 2916

6. Commissioning

Before commissioning, note the following directions and warnings:

Warning



Internal components and circuit boards of Grundfos RSI drive (except for the galvanically isolated I/O terminals) are live when it is connected to the mains potential. Coming into contact with this voltage is extremely dangerous and may cause death or severe injury.

Warning



The motor terminals U, V, W and the brake resistor terminals R-/R+ are live when Grundfos RSI drive is connected to the mains, even if the motor is not running.

Warning



The control I/O-terminals are isolated from the mains potential. However, the *relay outputs and other I/O-terminals may have a dangerous control voltage* present even when Grundfos RSI drive is disconnected from the mains.

Warning



Do not make any connections to or from the frequency converter when it is connected to the mains.

Warning



After disconnecting the AC drive from the mains, wait until the fan stops and the indicators on the powerhead go out. Wait an additional 30 seconds before doing any work on the connections of Grundfos RSI Drive. Do not open the unit before this time has expired. After expiration of this time, use a measuring equipment to absolutely ensure that no voltage is present. *Always ensure absence of voltage before starting any electrical work!*

Warning



Before connecting the AC drive to mains make sure that the powerhead Grundfos RSI Drive is mounted firmly on the terminal box.

6.1 Commissioning of the drive

Read carefully the safety instructions in section 1. *Symbols used in this document* and above and follow them.

After the installation:

- | | |
|--------------------------|---|
| <input type="checkbox"/> | Check that both the frequency converter and the motor are grounded. |
| <input type="checkbox"/> | Check that the mains and motor cables comply with the requirements given in section 5. <i>Control unit</i> . |
| <input type="checkbox"/> | Check that the control cables are located as far as possible from the power cables. |
| <input type="checkbox"/> | Check that the shields of the shielded cables are connected to protective earth marked with  . |
| <input type="checkbox"/> | Check the tightening torques of all terminals. |
| <input type="checkbox"/> | Check that the wires do not touch the electrical components of the drive. |
| <input type="checkbox"/> | Check that the common inputs of digital input groups are connected to +24V or ground of the I/O terminal. |
| <input type="checkbox"/> | Check the quality and quantity of cooling air. |
| <input type="checkbox"/> | Check the inside of the frequency converter for condensation. |
| <input type="checkbox"/> | Check that all Start/Stop switches connected to the I/O terminals are in the Stop-position. |
| <input type="checkbox"/> | Before connecting the frequency converter to mains: Check mounting and condition of all fuses and other protective devices. |
| <input type="checkbox"/> | Run the Startup Wizard (see the Application Manual). |

6.2 Changing EMC protection class

If your supply network is an IT (impedance-grounded) system but your AC drive is EMC-protected according to class C1 or C2 you need to modify the EMC protection of the AC drive to EMC-level T (C4). This is done by removing the EMC screws as described below:



Warning

Do not perform any modifications on the AC drive when it is connected to mains.

Separate the powerhead and the terminal box. Turn the powerhead upside down and remove the two screws marked in fig. 37 (for Frame A), fig. 38 (for Fame B) and in fig. 40(for Frame C).

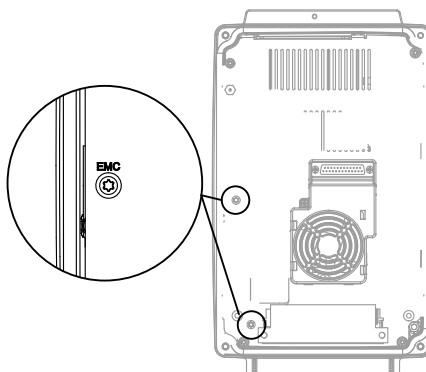
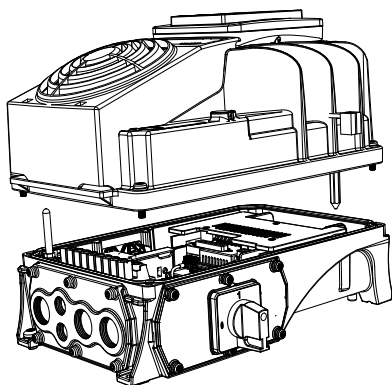

Fig. 36 Locations of EMC screws in Frame A

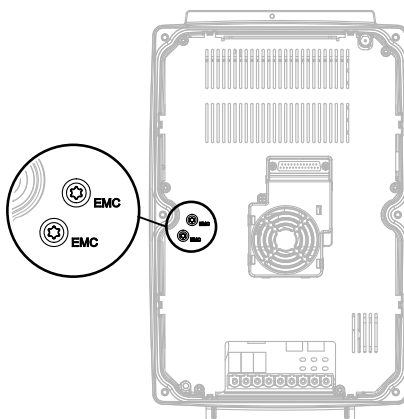
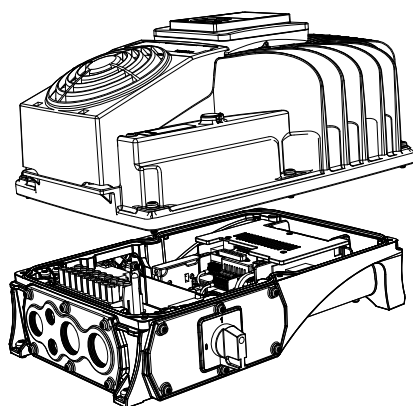
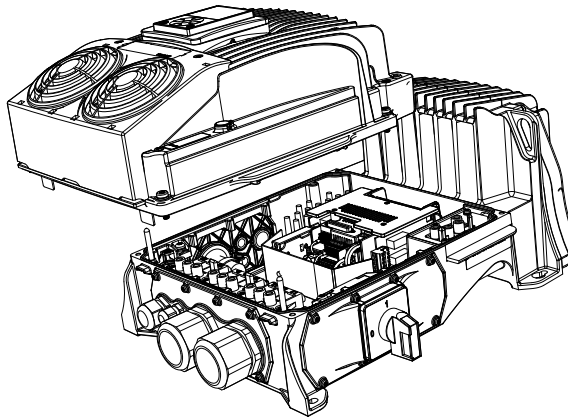

Fig. 37 Locations of EMC screws in Frame B

TM06 6981 2916 - TM06 6983 2916

TM06 6978 2916 - TM06 6980 2916



TM06 7027 2916

Fig. 38 Powerhead separated from the terminal box in Frame C

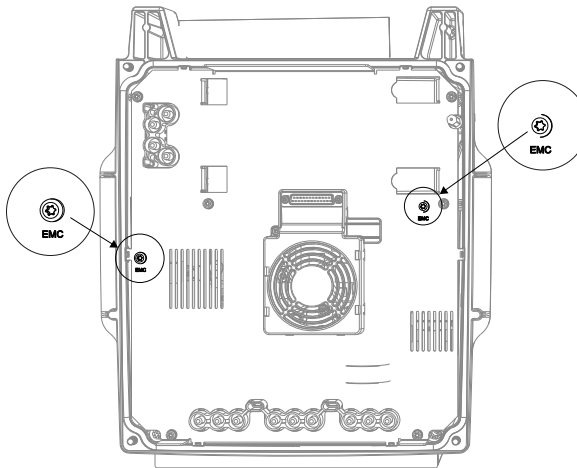

TM06 6982 2916

Fig. 39 Locations of EMC screws in Frame C

Before connecting the AC drive to mains make sure that the EMC protection class settings of the drive are appropriately made.

Caution

After having performed the change write "EMC level modified" on the sticker included in the Grundfos RSI delivery (see below) and note the date. Unless already done, attach the sticker close to the name plate of the AC drive.

Note

| | |
|----------------------------|--------------|
| Product modified | |
| ----- | Date: ----- |
| ----- | Date: ----- |
| EMC-level modified C1 → C4 | Date: DDMMYY |

TM06 7138 2916

6.3 Running the motor

MOTOR RUN CHECK LIST

 **Warning**
Before starting the motor, check that the motor is mounted properly and ensure that the machine connected to the motor allows the motor to be started.

 **Warning**
Set the maximum motor speed (frequency) according to the motor and the machine connected to it.

 **Warning**
Before reversing the motor make sure that this can be done safely.

 **Warning**
Make sure that no power correction capacitors are connected to the motor cable.

 **Warning**
Make sure that the motor terminals are not connected to mains potential.

6.3.1 Cable and motor insulation checks

1. Motor cable insulation checks
Disconnect the motor cable from terminals U, V and W of the AC drive and from the motor. Measure the insulation resistance of the motor cable between each phase conductor as well as between each phase conductor and the protective ground conductor. The insulation resistance must be $>1M\Omega$ at ambient temperature of 20°C (68 °F).
2. Mains cable insulation checks
Disconnect the mains cable from terminals L1, L2 and L3 of the AC drive and from the mains. Measure the insulation resistance of the mains cable between each phase conductor as well as between each phase conductor and the protective ground conductor. The insulation resistance must be $>1M\Omega$ at ambient temperature of 20°C (68 °F).
3. Motor insulation checks
Disconnect the motor cable from the motor and open the bridging connections in the motor connection box. Measure the insulation resistance of each motor winding. The measurement voltage must equal at least the motor nominal voltage but not exceed 1000 V. The insulation resistance must be $>1M\Omega$ at ambient temperature of 20°C (68 °F).

6.4 Maintenance

In normal conditions, the AC drive is maintenance-free. However, regular maintenance is recommended to ensure trouble-free operation and longevity of the drive. We recommend the table below is followed for maintenance intervals.

Note Because of capacitor type (thin film capacitors), reforming of capacitors is not necessary.

| Maintenance interval | Maintenance action |
|---|---|
| Regularly and according to general maintenance interval | <ul style="list-style-type: none"> • Check tightening torques of terminals |
| 6...24 months (depending on environment) | <ul style="list-style-type: none"> • Check input and output terminals and control I/O terminals. • Check operation of cooling fan • Check the heatsink for dust and clean if necessary |
| 6...20 years | <ul style="list-style-type: none"> • Change main fan |
| 10 years | <ul style="list-style-type: none"> • Replace the battery of the RTC. |

7. Technical data

7.1 AC drive power ratings

7.1.1 Mains voltage 3 AC 208-240 V

Power ratings of Grundfos RSI, supply voltage 3 AC 208-240 V

| Mains voltage 3AC 208-240V, 50/60 Hz | | | | | | | |
|--------------------------------------|----------------|-------------------|------------------------------------|--------------------------|-------------------|-------------------|------|
| Frame | Converter type | Input current [A] | Loadability | | | Motor shaft power | |
| | | | Rated continuous current I_N [A] | 50% overload current [A] | Max current I_S | 230V supply | |
| | | | | | | [kW] | [HP] |
| A | 0008 | 7.2 | 8.0 | 12.0 | 16.0 | 1.5 | 2.0 |
| | 0011 | 9.7 | 11.0 | 16.5 | 22.0 | 2.2 | 3.0 |
| | 0012 | 10.9 | 12.5 | 18.8 | 25.0 | 3.0 | 4.0 |
| B | 0018 | 16.1 | 18.0 | 27.0 | 36.0 | 4.0 | 5.0 |
| | 0024 | 21.7 | 24.2 | 36.3 | 48.4 | 5.5 | 7.5 |
| | 0031 | 27.7 | 31.0 | 46.5 | 62.0 | 7.5 | 10.0 |
| C | 0048 | 43.8 | 48.0 | 72.0 | 96.0 | 11.0 | 15.0 |
| | 0062 | 57.0 | 62.0 | 93.0 | 124.0 | 15.0 | 20.0 |

The rated currents in given ambient temperatures (in [7.1.1 Mains voltage 3 AC 208-240 V](#)) are achieved only when the switching frequency is equal to or less than the factory default.

Note

7.1.2 Mains voltage 3 AC 380-440 V

Power ratings of Grundfos RSI, supply voltage 3AC 380-440 V, high overload.

| Mains voltage 3AC 380-415 V, 50/60 Hz | | | | | | | |
|---------------------------------------|----------------|-------------------|------------------------------------|--------------------------|-------------------|-------------------|------|
| Frame | Converter type | Input current [A] | Loadability | | | Motor shaft power | |
| | | | Rated continuous current I_N [A] | 50% overload current [A] | Max current I_S | 400V | 480V |
| | | | | | | [kW] | [HP] |
| A | 0005 | 5.4 | 5.6 | 8.4 | 11.2 | 2.2 | 3.0 |
| | 0008 | 8.1 | 8.0 | 12.0 | 16.0 | 3.0 | 5.0 |
| | 0009 | 9.3 | 9.6 | 14.4 | 19.2 | 4.0 | 5.0 |
| | 0012 | 11.3 | 12.0 | 18.0 | 24.0 | 5.5 | 7.5 |
| B | 0016 | 15.4 | 16.0 | 24.0 | 32.0 | 7.5 | 10.0 |
| | 0023 | 21.3 | 23.0 | 34.5 | 46.0 | 11.0 | 15.0 |
| | 0031 | 28.4 | 31.0 | 46.5 | 62.0 | 15.0 | 20.0 |
| C | 0038 | 36.7 | 38.0 | 57.0 | 76.0 | 18.5 | 25.0 |
| | 0046 | 43.6 | 46.0 | 69.0 | 92.0 | 22.0 | 30.0 |
| | 0061 | 58.2 | 61.0 | 91.5 | 122.0 | 30.0 | 40.0 |

Power ratings of Grundfos RSI, supply voltage 3 AC 380-480/500 V, low overload.

| Mains voltage 3AC 380-480/500V, 50/60 Hz | | | | | | | |
|--|----------------|-------------------|------------------------------------|--------------------------|-------------------|-------------------|------------|
| Frame | Converter type | Input current [A] | Load ability | | | Motor shaft power | |
| | | | Rated continuous current I_N [A] | 10% overload current [A] | Max current I_s | 400 V [kW] | 480 V [HP] |
| C | 0072 | 67.5 | 72.0 | 80.0 | 108.0 | 37.0 | 50.0 |

Note The rated currents in given ambient temperatures (in the tables of section 7.1.2 Mains voltage 3 AC 380-480/500 V) are achieved only when the switching frequency is equal to or less than the factory default.

7.1.3 Definitions of overloadability

High overload: Following continuous operation at rated output current I_N , the converter supplies 150 % * I_N for 1 min, followed by a period of at least 9 min at I_N or below.

Example: If the duty cycle requires 150 % rated current for 1 min in every 10 min, the remaining 9 min must be at rated current I_N or less.

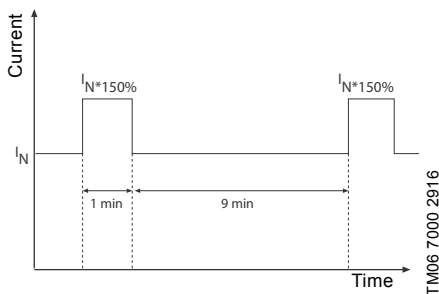

Fig. 40 High overload

Low overload: Following continuous operation at rated output current I_N , the converter supplies 110 % * I_N for 1 min, followed by a period of at least 9 min at I_N or below.

Example: If the duty cycle requires 110% rated current for 1 min in every 10 min, the remaining 9 min must be at rated current I_N or less.

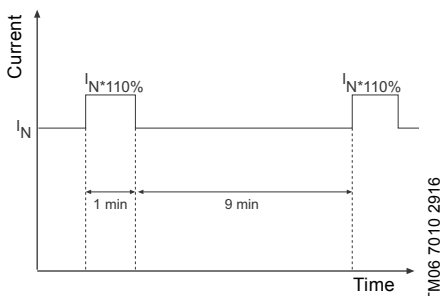

Fig. 41 Low overload

Note For more information, please refer to IEC61800-2 (IEC:1998) Standard.

7.2 Brake resistor ratings

Make sure that the resistance is higher than the minimum resistance defined. The power handling capacity must be sufficient for the application.

Recommended minimum brake resistor values for Grundfos RSI AC drives:

| Mains Voltage 3AC 208-240V, 50/60 Hz | | | |
|--------------------------------------|------|--------------------------------------|--------------------------------|
| Frame | Type | Minimum Resistance recommended [ohm] | Brake power @405 VDC [kW (hp)] |
| A | 0008 | 25 | 6.6 (8.9) |
| | 0011 | 25 | 6.6 (8.9) |
| | 0012 | 25 | 6.6 (8.9) |
| B | 0018 | 15 | 10.9 (14.6) |
| | 0024 | 15 | 10.9 (14.6) |
| | 0031 | 10 | 16.4 (22) |
| C | 0048 | 8 | 20.5 (27.5) |
| | 0062 | 8 | 20.5 (27.5) |

| Mains Voltage 3AC 380-480/500V, 50/60 Hz | | | |
|--|------|--------------------------------------|--------------------------------|
| Frame | Type | Minimum Resistance recommended [ohm] | Brake power @845 VDC [kW (hp)] |
| A | 0005 | 50 | 14.3 (19.2) |
| | 0008 | 50 | 14.3 (19.2) |
| | 0009 | 50 | 14.3 (19.2) |
| | 0012 | 50 | 14.3 (19.2) |
| B | 0016 | 30 | 23.8 (31.9) |
| | 0023 | 30 | 23.8 (31.9) |
| | 0031 | 20 | 35.7 (47.9) |
| C | 0038 | 15 | 47.6 (63.8) |
| | 0046 | 15 | 47.6 (63.8) |
| | 0061 | 15 | 47.6 (63.8) |
| | 0072 | 15 | 47.6 (63.8) |

7.3 Grundfos RSI - technical data

| | | |
|--------------------------------|---|---|
| Mains connection | Input voltage U_{in} | 3 AC 208 ... 240 V 3 AC 380 ... 480 V 3 AC 380 ... 500 V |
| | Input voltage tolerance | -15 % ... +10 % continuously |
| | Input frequency | 50/60 Hz |
| | Protection class | I |
| | Input frequency tolerance | 47.5 ... 66 Hz |
| | Connection to mains | Once per minute or less |
| | Starting delay | < 7 s |
| | Supply network | TN- and IT-network (cannot be used with corner earthed network) |
| Short-circuit current | Max. short-circuit current has to be < 100 kA | |
| Motor connection | Output voltage | 3 AC 0... U_{in} |
| | Rated output current | I_N ; Ambient temperature max. +40 °C. See sections 7.1.1 Mains voltage 3 AC 208-240 V and 7.1.2 Mains voltage 3 AC 380-480/500 V . |
| | Overload output current | 1.5 x I_N (1 min/10 min); 1.1 x I_N (1 min/10 min) only for MM6 0072. See 7.1.1 Mains voltage 3 AC 208-240 V and 7.1.2 Mains voltage 3 AC 380-480/500 V . |
| | Starting output current | I_S for 2 s every 20 s. See 7.1.1 Mains voltage 3 AC 208-240 V and 7.1.2 Mains voltage 3 AC 380-480/500 V . |
| | Output frequency | 0...320 Hz (standard) |
| | Frequency resolution | 0.01 Hz |
| | Protection class | I |
| | Motor characteristics | AC squirrel cage motors Permanent magnet motors |
| Control characteristics | Cable type | Screened motor cable |
| | Cable maximum length (full EMC compliance) | C2: 15 m (50ft) |
| | Switching frequency | Programmable 1.5 ... 16 kHz; Default: 6 kHz (Frame A and B); 4 kHz (Frame C) Automatic switching frequency derating in case of overheating |
| | Frequency reference | |
| | Analogue input | Resolution 0.1 % (10-bit), accuracy $\pm 1\%$ |
| | Panel reference | Resolution 0.01 Hz |
| | Field weakening point | 8 ... 320 Hz |
| | Acceleration time | 0.1 ... 3000 sec |
| Control connections | Deceleration time | 0.1 ... 3000 sec |
| | Braking | Brake chopper standard in all frames External brake resistor optional |
| | See section 5. Control unit . | |

| | | |
|----------------------------------|----------------------------------|---|
| Communication interface | Fieldbus | Standard: Serial communication (RS485/Modbus); Ethernet IP, Profinet IO, Modbus TCP, Bacnet IP Optional: CanOpen; Profibus DP, DeviceNet, Lonworks, AS-interface |
| | Status indicators | Drive status indicators (LED) on top side (POWER, RUN, FAULT, READY) |
| Ambient conditions | Ambient operating temperature | -10 °C (14°F) ... +40 °C (104°F) |
| | Extended temperature range | up to 60 °C (140°F) with current derating (see section 1.7 Extended temperature range) |
| | Storage temperature | -40 °C (-40°F) ... +70 °C (158°F) |
| | Relative humidity | 0 to 100 % R _H |
| | Pollution degree | PD2 used for PCB design. However the drives are suitable for outdoor use because of dust-tight enclosure to numeral 6 [acc. to IEC 60529]. |
| | Altitude | 100 % load capacity (no derating) up to 1,000 m (3280 ft); derating 1 % / 100 m (328 ft) at 1,000 to 3,000 m (3280 to 9842 ft) |
| | Stationary vibration: sinusoidal | 3 Hz ≤ f ≤ 8,72 Hz: 10 mm (0.4 in) 8,72 Hz ≤ f ≤ 200 Hz: 3g [3M7 acc. to IEC 60721-3-3] |
| | Shock/Bump | 25 g / 6 ms [3M7 acc. to IEC 60721-3-3] |
| | Degree of protection | IP66 / Type 4X |
| | Noise Level | Average noise level (min-max) in dB (A) |
| Directives | EMC | 2004/108/EC |
| | Low Voltage Directive | 2006/95/EC |
| | RoHS | 2002/95/EC |
| | WEEE | 2012/19/EC |
| Standards | Immunity | EN 61800-3 (2004), 1 st and 2 nd environment |
| | Emissions | EN 61800-3 (2004), Category C2 The drive can be modified for IT-networks. |
| | THD | EN 61000-3-12 (see section 1.8 Electro-magnetic compatibility (EMC)) |
| | Safety | EN 61800-5-1 |
| Production quality | ISO 9001 | |
| Approvals | Functional Safety | TÜV - Tested |
| | Electrical Safety | TÜV - Tested |
| | EMC | TÜV - Tested |
| | USA, Canada | cULus approval, file number E171278 |
| Declaration of Conformity | Korea | KC mark |
| | Australia | C-tick Declaration of Conformity Registration number E2204 |
| | Europe | EC Declaration of Conformity |

| | | |
|--------------------|--|--|
| Protections | Undervoltage trip limit | Depends on supply voltage (0.8775*supply voltage): Supply voltage 240 V: Trip limit 211 V Supply voltage 400 V: Trip limit 351 V Supply voltage 480 V: Trip limit 421 V |
| | Overvoltage fault protection | Yes |
| | Earth fault protection | Yes |
| | Mains supervision | Yes |
| | Motor phase supervision | Yes |
| | Overcurrent protection | Yes |
| | Unit overtemperature protection | Yes |
| | Motor overload protection | Yes. These devices provide motor overload protection at 105% of full load amperes. |
| | Motor stall protection | Yes |
| | Motor underload protection | Yes |
| | Short-circuit protection of +24 V and +10 V reference voltages | Yes |
| | Thermal motor protection | Yes (by PTC) |

7.3.1 Technical information on control connections

| Standard I/O | | |
|--------------|-------------------------------------|---|
| Terminal | Signal | Technical information |
| 1 | Reference output | +10 V, +3 %; Maximum current 10 mA |
| 2 | Analogue input, voltage or current | Analogue input channel 1 0-20 mA ($R_i = 250 \Omega$) 0-10 V ($R_i = 200 \text{ k}\Omega$) Resolution 0.1 %, accuracy $\pm 1 \%$ Selection V/mA with dip-switches (see section 5. <i>Control unit</i>). Default 0-10 V Short-circuit protection. |
| 3 | Analogue input common | Differential input if not connected to ground; Allows $\pm 20 \text{ V}$ differential mode voltage to GND |
| 4 | Analogue input, voltage or current | Analogue input channel 2 0-20 mA ($R_i = 250 \Omega$) 0-10 V ($R_i = 200 \text{ k}\Omega$) Resolution 0.1 %, accuracy $\pm 1 \%$ Selection V/mA with dip-switches (see section 5. <i>Control unit</i>). Default 0-20 mA Short-circuited protected. |
| 5 | Analogue input common | Differential input if not connected to ground; Allows 20V differential mode voltage to GND |
| 6 | 24V aux. voltage | +24 V, $\pm 10 \%$, max volt. ripple < 100 mVrms; max. 250 mA Short-circuit protected |
| 7 | I/O ground | Ground for reference and controls (connected internally to frame earth through 1 M Ω) |
| 8 | Digital input 1 | Positive or negative logic |
| 9 | Digital input 2 | $R_i = \text{min. } 5 \text{ k}\Omega$ |
| 10 | Digital input 3 | 18 ... 30 V = "1" 0 ... 5 V = "0" |
| 11 | Common A for DIN1-DIN6. | Digital inputs can be isolated from ground, see section 5. <i>Control unit</i> . Default: connected to ground. |
| 12 | 24V aux. voltage | Same as terminal 6. |
| 13 | I/O ground | Ground for reference and controls (connected internally to frame earth through 1 M Ω) |
| 14 | Digital input 4 | Positive or negative logic |
| 15 | Digital input 5 | $R_i = \text{min. } 5 \text{ k}\Omega$ |
| 16 | Digital input 6 | 18 ... 30 V = "1" 0 ... 5 V = "0" |
| 17 | Common A for DIN1-DIN6. | Digital inputs can be isolated from ground, see section 5. <i>Control unit</i> . Default: connected to ground. |
| 18 | Analogue output, voltage or current | Analogue output channel 1 0-20 mA ($R_L < 500 \Omega$) 0-10 V ($R_L > 1 \text{ k}\Omega$) Resolution 0.1 %, accuracy $\pm 2 \%$ |
| 19 | Analogue output common | Selection V/mA with dip-switches (see section 5. <i>Control unit</i>). Default 0-20 mA Short-circuited protected. |
| 30 | 24V auxiliary input voltage | Can be used with an external power supply (with a current limiter or fuse protected) to supply the control unit and fieldbus for backup purposes. Dimensioning: max. 1000 mA/control unit. |

| Standard I/O | | |
|--------------|--------|--|
| Terminal | Signal | Technical information |
| A | RS485 | Differential receiver/transmitter |
| B | RS485 | Set bus termination with dip switches (see page 39). Default: bus termination disconnected. |

| Relays | | |
|--|------------------|--|
| Relays with two change-over contact (SPDT) and a PTC thermistor input. 5,5 mm isolation between channels. | | |
| Terminal | Signal | Technical information |
| 21 | Relay output 1* | Switching capacity |
| 22 | | 24 VDC / 8 A 250 VAC / 8 A 125 VDC / 0.4 A |
| 23 | | Min. switching load |
| | | 5 V / 10 mA |
| 24 | Relay output 2* | Switching capacity |
| 25 | | 24 VDC / 8 A 250 VAC / 8 A 125 VDC / 0.4 A |
| 26 | | Min. switching load |
| | | 5 V / 10 mA |
| 28 | Thermistor input | Rtrip = 4.7 kΩ (PTC); Measuring voltage 3.5 V |
| 29 | | |

* If 230 VAC is used as control voltage from the output relays, the control circuitry must be powered with a separate isolation transformer to limit short circuit current and overvoltage spikes. This is to prevent welding on the relay contacts. Refer to standard EN 60204-1, section 7.2.9.

8. Options

The options available for Grundfos RSI are described below.

8.0.1 Installation

1. Remove the cable entry plate from the drive on the left-hand-side if the mains switch must be mounted on this side. Otherwise remove the

cable entry plate from the right-hand-side. See the fig. 44.

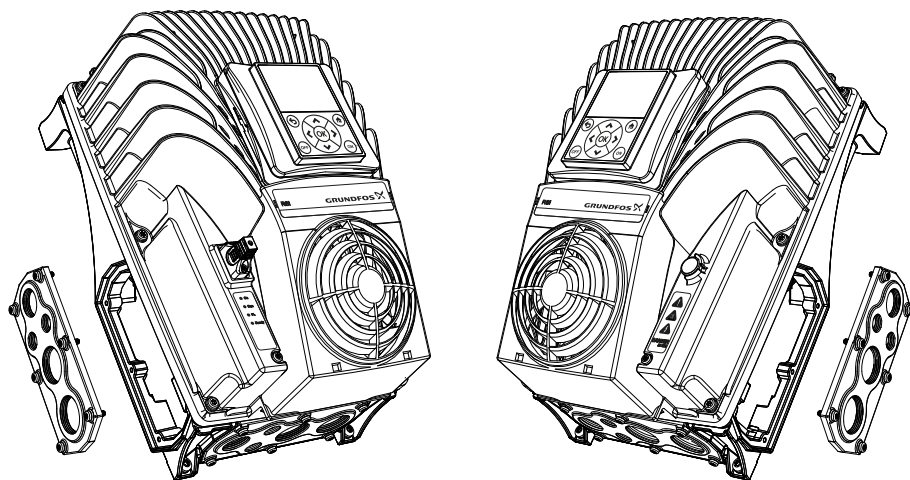

Fig. 42 Disconnect the cable entry plate: example for Frame B

TMO6 7016 3416

2. Remove the cable entry plate from the bottom side of the terminal box by loosening the six screws. Cables pass through this inlet hole.

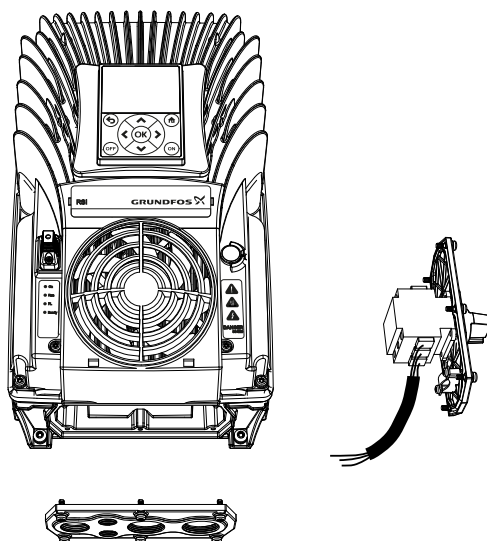

Fig. 43 Cable entry plate from the bottom side of the drive

3. Remove the powerhead from the terminal box by loosening the screws on the top side of the drive.

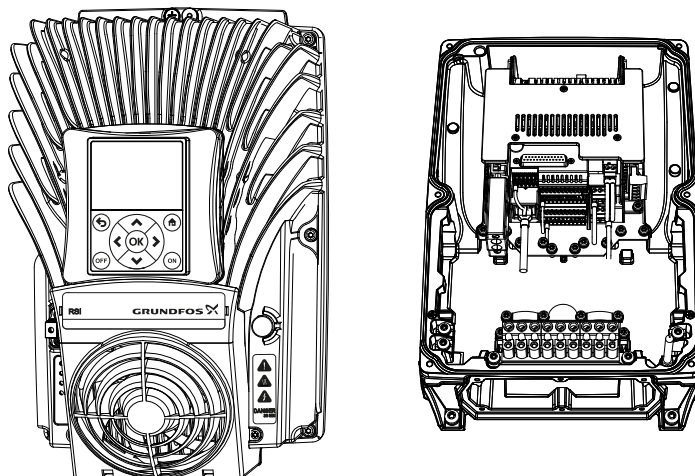

Fig. 44 Powerhead separated from the terminal box

TM06 7014 3416

TM06 70173416

4. Connect the supply cable to the Mains switch passing through the cable entry plate of the bottom side (use the cable gland for sealing the cable to the gland plate) and then through the terminal box as shown in the figure below.

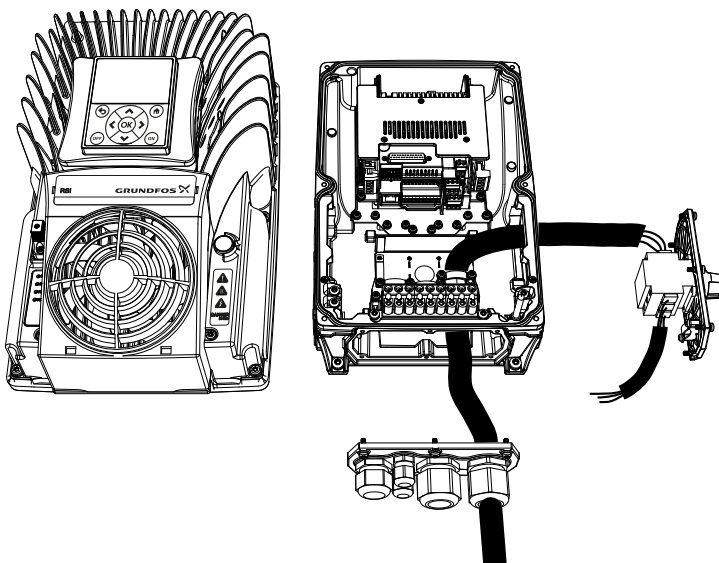
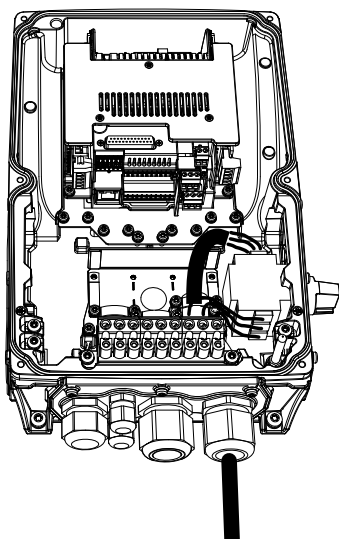

Fig. 45 Connection of the supply cable to the Mains switch (right-hand-side example)

5. Connect the cables from the Mains switch to the terminal box. The cables have to be connected to the terminals L1, L2 and L3.
6. Place the Mains switch plate with the cables in the groove and fix it with its screws.

TM06 7013 3416

7. Place the cable entry plate with the other cables (motor cable, brake cable, I/O cables) in the groove on the bottom side of the drive and fix it with its screws.



TM06 7011 2916

Fig. 46 Mains switch, cable entry and cables connected

8. Mount the powerhead on the terminal box with its screws: the installation process has been completed. See fig. 49.

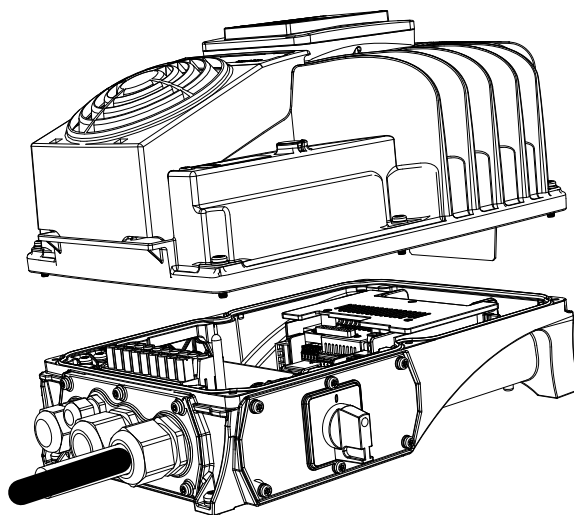

Fig. 47 Mount the powerhead on the terminal box

TM06 7012 2916

8.1 Control Keypad

The control keypad is the interface between the Grundfos RSI frequency converter and the user. With the control keypad it is possible to control the speed of a motor, to supervise the state of the equipment and to set the frequency converter's parameters.

The keypad is an option and can be delivered separately. The option includes the keypad, the keypad holder and three screws. You can use one screw to fix the keypad holder to the drive or three screws to fix the keypad holder to an enclosure/ cabinet or any special housing for the drive in which you want to have a remote keypad control available.

8.1.1 Mounting onto the drive

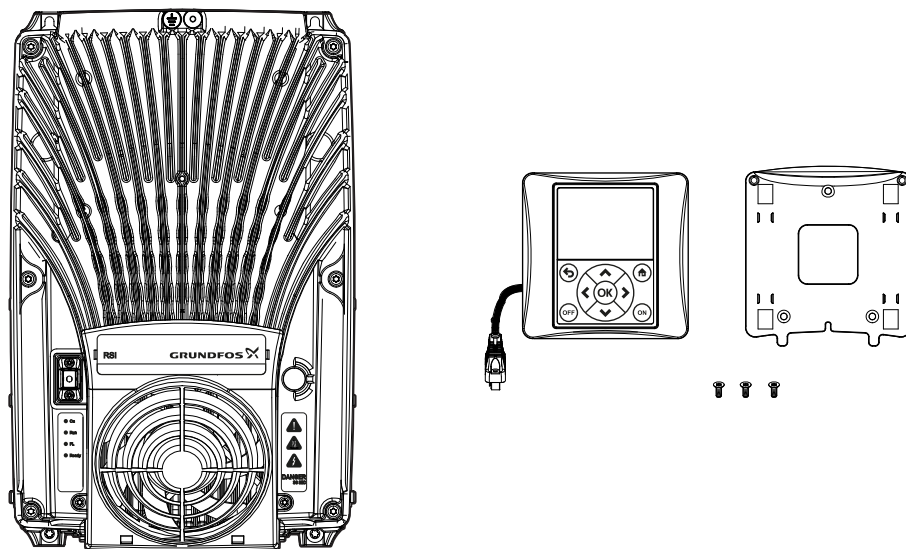
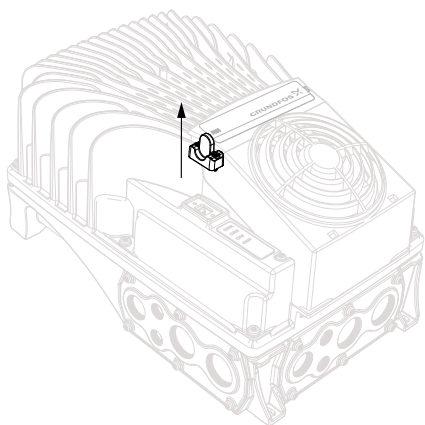

Fig. 48 Drive and the optional keypad kit

TM06 70043416

8.1.2 Installation

1. Remove the HMI cap from the drive as shown in the fig. 51.



TM06 7005 2916

Fig. 49 Disconnection of the HMI cap from the drive

2. Install the keypad holder with a screw as shown in the fig. 52. The metal sheets of the keypad holder have to be mounted under the fan holder as shown in the following figures.

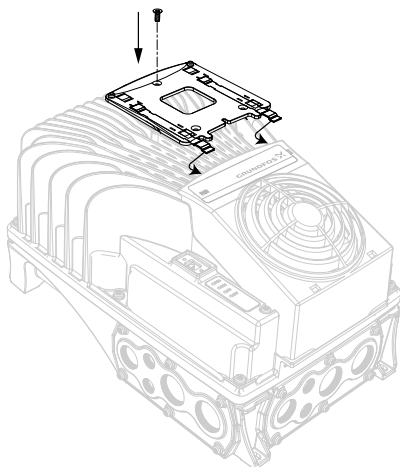

TM06 7006 2916

Fig. 50 Installation of the keypad holder on the powerhead

3. Connect the keypad to the drive and plug the cable on the HMI connector as shown in the fig. 53 and in the fig. 54.

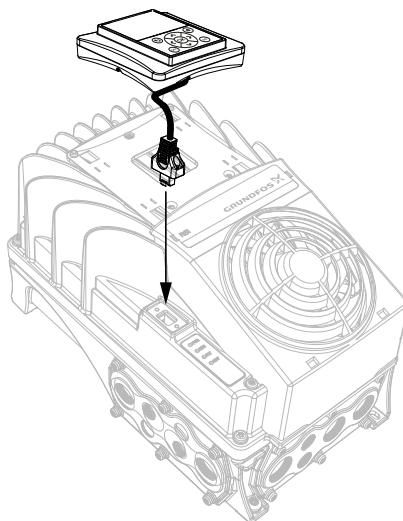

TM06 7007 2916

Fig. 51 Mounting of the keypad

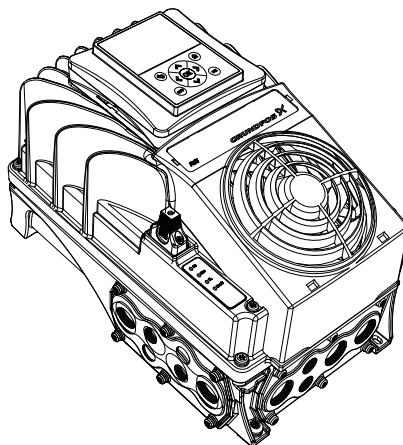

TM067008 2916

Fig. 52 Keypad mounted onto the drive. Tighten the fixing screws of the cable connector to the enclosure of the drive. This is to keep the high IP66 protection degree of the drive

8.1.3 Wall-mounting

The keypad can be mounted on the wall in a convenient location by using the same keypad holder and three screws provided with the keypad option kit.

1. Fix the keypad holder with three screws to the wall.

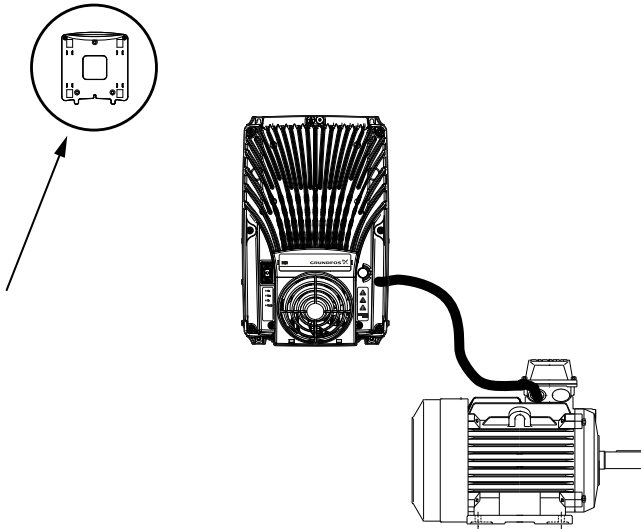

Fig. 53 Fix the keypad holder with three screws to the wall

2. Connect and fix the cable to the enclosure of the drive and hold the keypad to the wall.

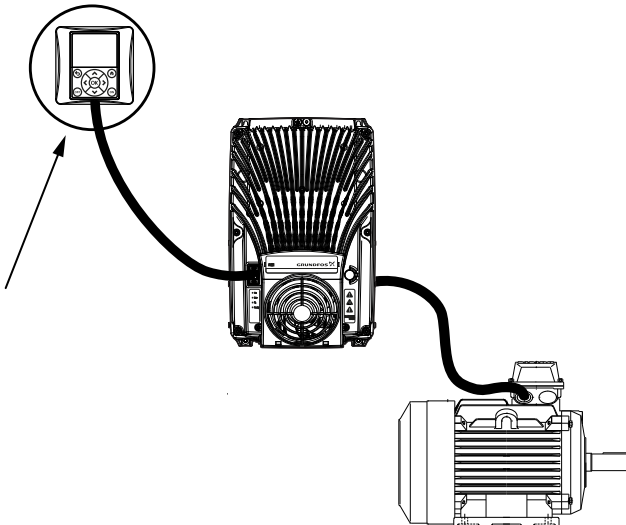

Fig. 54 Keypad connected to the drive

TM06 70263416

TM06 7029 2916

8.1.4 Graphical and Text keypad

There are two keypad types you can choose for your user interface: keypad with graphical display and keypad with text segment display (text keypad).

The button section of the keypad is identical for both keypad types.

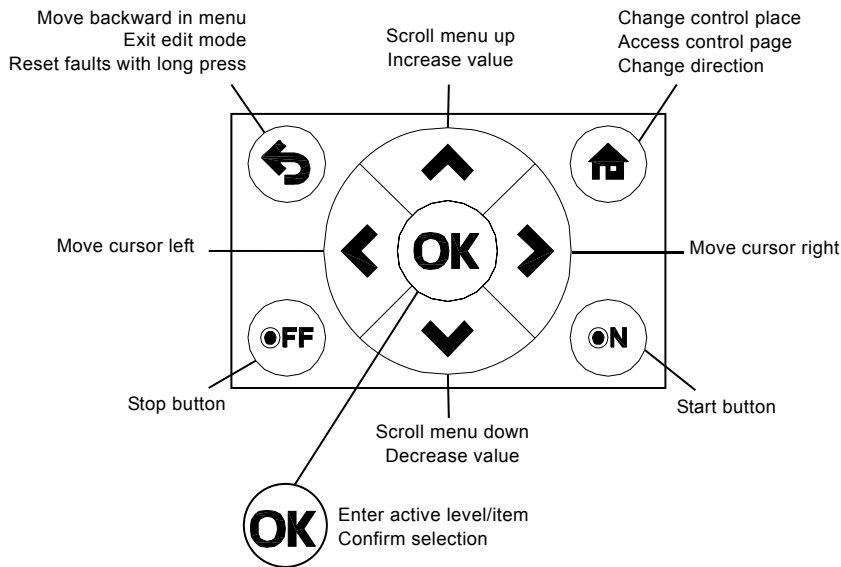

TM06 6958 2916

Fig. 55 Keypad buttons

8.1.5 Grundfos keypad with graphical display

The graphical keypad features an LCD display and 9 buttons.

Keypad display

The keypad display indicates the status of the motor and the drive and any irregularities in motor or drive functions. On the display, the user sees information about his present location in the menu structure and the item displayed.

Main menu

The data on the control keypad are arranged in menus and submenus. Use the Up and Down arrows to move between the menus. Enter the group/item by pressing the OK button and return to the former level by pressing the Back/Reset button.

The Location field indicates your current location. The Status field gives information about the present status of the drive. See fig. 56.

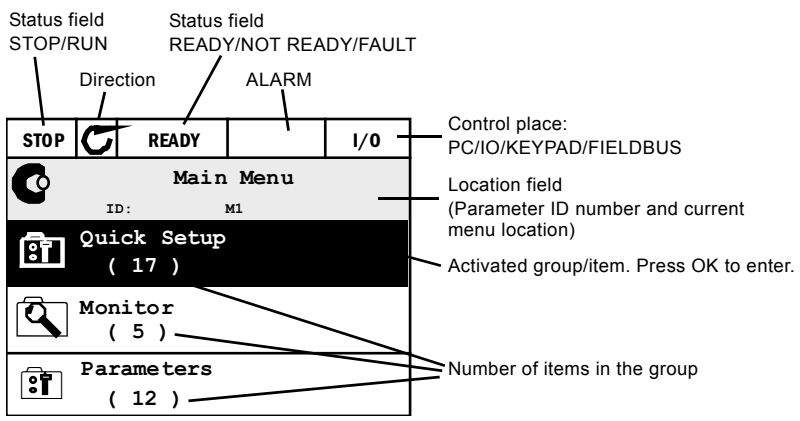

Fig. 56 Main menu

TM06 7032 2916

Using the graphical keypad

Editing values

The selectable values can be accessed and edited in two different ways on the graphical keypad.

Parameters with one valid value

Typically, one parameter is set one value. The value is selected either from a list of values (see example below) or the parameter is given a numerical value from a defined range (e.g. 0.00...50.00 Hz).

Change value of a parameter following the procedure below:

1. Locate the parameter.
2. Enter the Edit mode.
3. Set new value with the arrow buttons up/down. You can also move from digit to digit with the arrow buttons left/right if the value is numerical and then change the value with the arrow buttons up/down.
4. Confirm change with OK button or ignore change by returning to previous level with Back/Reset button.

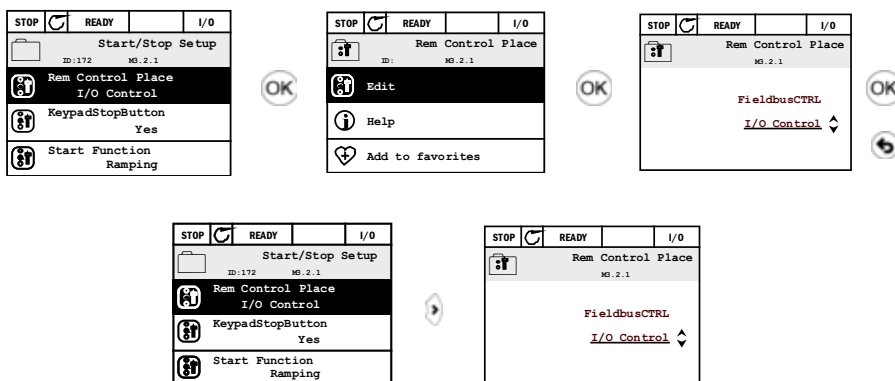

Fig. 57 Typical editing of values on graphical keypad (text value)

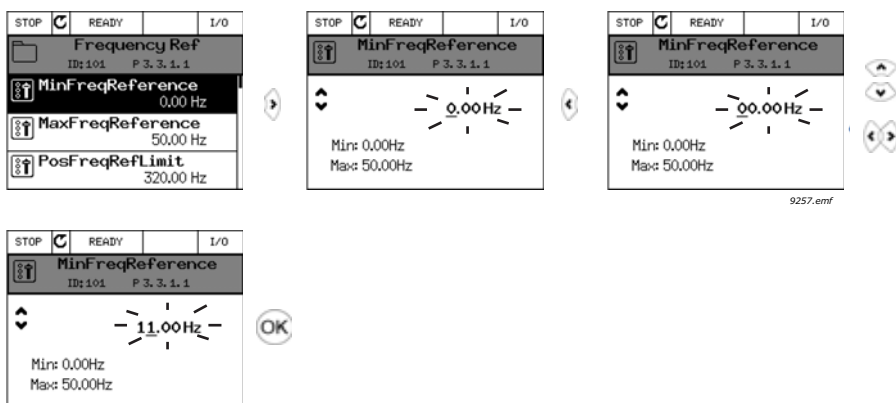

Fig. 58 Typical editing of values on graphical keypad (numerical value)

Parameters with checkbox selection

Some parameters allow selecting several values. Make a checkbox selection at each value you wish to activate as instructed below.



Symbol for checkbox selection

Fig. 59 Applying the checkbox value selection on graphical keypad

Resetting fault

For instructions to reset a fault, See “Fault Tracing” on page 73..

Home button

The Home button is used for four functions:

1. to quickly access the Control page,
2. to easily change between the Local (Keypad) and Remote control places,
3. to change the rotation direction and
4. to quickly edit a parameter value.

Control places

The control place is the source of control where the drive can be started and stopped. Every control place has its own parameter for selecting the frequency reference source. The Local control place is always the keypad. The Remote control place is determined by parameter P3.2.1 (I/O or Fieldbus). The selected control place can be seen on the status bar of the keypad.

Remote control place

I/O A, I/O B and Fieldbus can be used as remote control places. I/O A and Fieldbus have the lowest priority and can be chosen with parameter P3.2.1 (Rem Control Place). I/O B, again, can bypass the remote control place selected with parameter P3.2.1 using a digital input. The digital input is selected with parameter P3.5.1.7 (I/O B Ctrl Force).

Local control

Keypad is always used as control place while in local control. Local control has higher priority than remote control. Therefore, if, for example, bypassed by parameter P3.5.1.7 through digital input while in Remote, the control place will still switch to Keypad if Local is selected. Switching between Local and Remote Control can be done by pressing the FUNCT-button on the keypad or by using the "Local/Remote" (ID211) parameter.

Changing control places

Change of control place from Remote to Local (keypad).

1. Anywhere in the menu structure, push the home button.
2. Push the Arrow up or the Arrow down button to select Local/Remote and confirm with the OK button.
3. On the next display, select Local or Remote and again confirm with the OK button.
4. The display will return to the same location as it was when the home button was pushed. However, if the Remote control place was changed to Local (Keypad) you will be prompted for keypad reference.

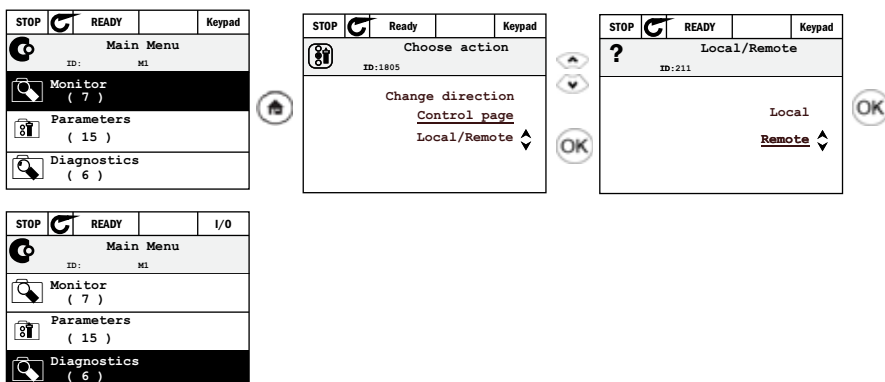

TM06 6959 2916

Fig. 60 Changing control places

Accessing the control page

The control page is meant for easy operation and monitoring of the most essential values.

1. Anywhere in the menu structure, push the home button.
2. Push the Arrow up or the Arrow down button to select Control page and confirm with the OK button.

3. The control page appears

If keypad control place and keypad reference are selected to be used you can set the Keypad Reference after having pressed the OK button. If other control places or reference values are used the display will show Frequency reference which is not editable. The other values on the page are Multimonitoring values. You can choose which values appear here for monitoring.

TM06 6960 2916

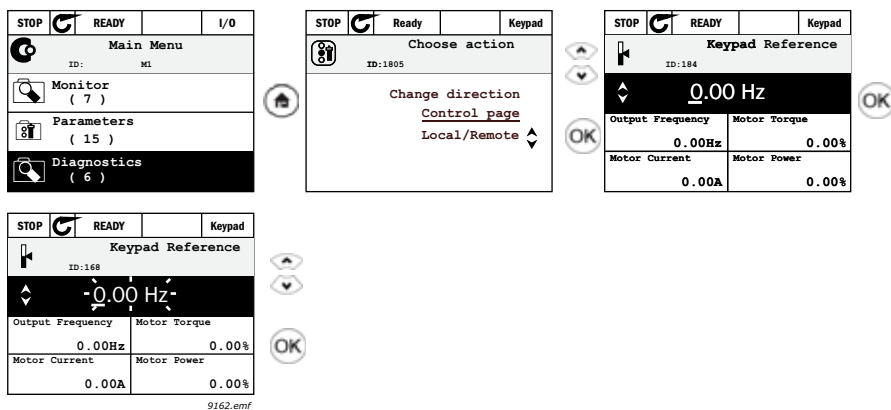

Fig. 61 Accessing Control page

Changing direction

the arrow indication in the status field changes.

Rotation direction of the motor can quickly be changed by applying the Home button.

Note Changing direction command is not visible in the menu unless the selected control place is Local.

1. Anywhere in the menu structure, push the home button.
2. Push the Arrow up or the Arrow down button to select Change direction and confirm with the OK button.
3. Then choose the direction you wish to run the motor to. The actual rotation direction is blinking. Confirm with the OK button.
4. The rotation direction changes immediately and

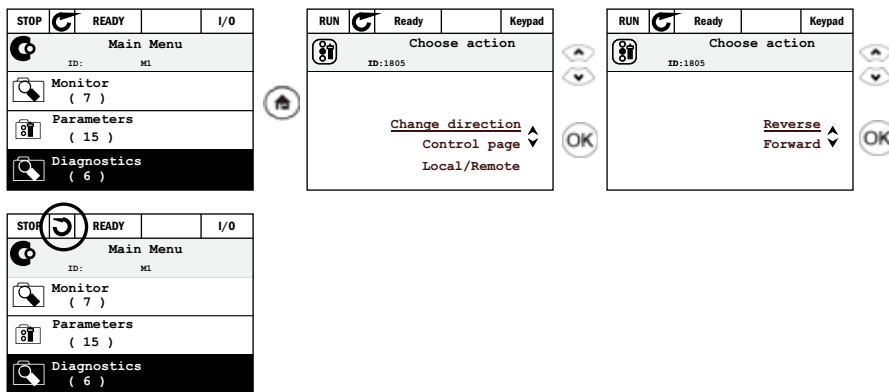

Fig. 62 Changing direction

Quick edit

Through the Quick edit functionality you can quickly access the desired parameter by entering the parameter's ID number.

1. Anywhere in the menu structure, push the home button.
2. Push the Arrow up or the Arrow down buttons to select Quick Edit and confirm with the OK button.
3. Then enter the ID number of parameter or monitoring value you wish to access. Press OK button to confirm.
4. Requested Parameter/Monitoring value appears on the display (in editing/monitoring mode.)

TM06 6961 2916

Copying parameters

Note This feature is available with graphical keypad only.

The parameter copy function can be used to copy parameters from one drive to another.

The parameters are first saved to the keypad, then the keypad is detached and connected to another drive. Finally the parameters are downloaded to the new drive restoring them from the keypad.

Before any parameters can successfully be copied from one drive to another the drive has to be stopped when the parameters are downloaded.

- First go into User settings menu and locate the Parameter backup submenu. In the Parameter backup submenu, there are three possible functions to be selected:
- Restore factory defaults will re-establish the parameter settings originally made at the factory.
- By selecting Save to keypad you can copy all parameters to the keypad.
- Restore from keypad will copy all parameters from keypad to a drive.

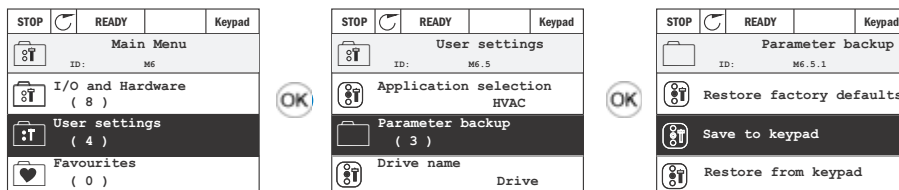

TM06 7136 2916

Fig. 63 Parameter copy

Note: If the keypad is changed between drives of different sizes, the copied values of these parameters will not be used:

- Motor nominal current (P3.1.1.4)
- Motor nominal voltage (P3.1.1.1)
- Motor nominal speed (P3.1.1.3)
- Motor nominal power (P3.1.1.6)
- Motor nominal frequency (P3.1.1.2)
- Motor cos phi (P3.1.1.5)
- Switching frequency (P3.1.2.3)
- Motor current limit (P3.1.3.1)
- Stall current limit (P3.9.3.2)
- Stall time limit (P3.9.3.3)
- Stall frequency (P3.9.3.4)
- Maximum frequency (P3.3.1.2)

Help texts

The graphical keypad features instant help and information displays for various items.

All parameters offer an instant help display. Select Help and press the OK button.

Text information is also available for faults, alarms and the startup wizard.

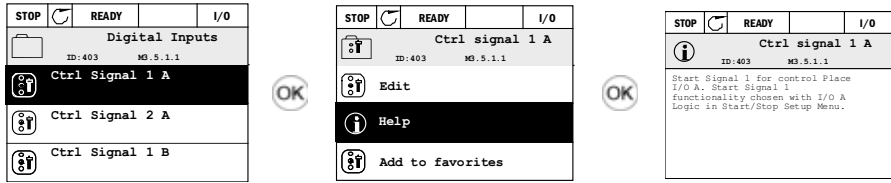

Fig. 64 Help text example

Adding item to favourites

You might need to refer to certain parameter values or other items often. Instead of locating them one by one in the menu structure, you may want to add them to a folder called Favourites where they can easily be reached.

To add an item to the Favourites.

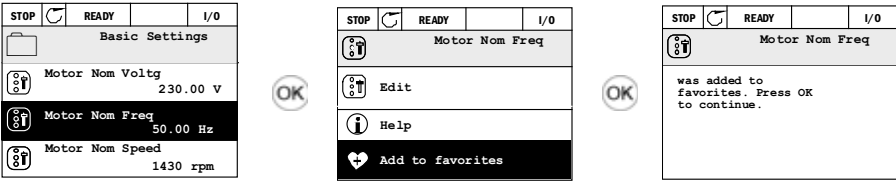

Fig. 65 Adding item to Favourites

8.1.6 Grundfos keypad with text segment display

You can also choose a Keypad with text segment display (Text keypad) for your user interface. It has mainly the same functionalities as the keypad with graphical display although some of these are somewhat limited.

Keypad display

The keypad display indicates the status of the motor and the drive and any irregularities in motor or drive functions. On the display, the user sees information about his present location in the menu structure and the item displayed. If the text on the text line is too long to fit in the display, the text will scroll from left to right to reveal the whole text string.

Main menu

The data on the control keypad are arranged in menus and submenus. Use the Up and Down arrows to move between the menus. Enter the group/item by pressing the OK button and return to the former level by pressing the Back/Reset button.

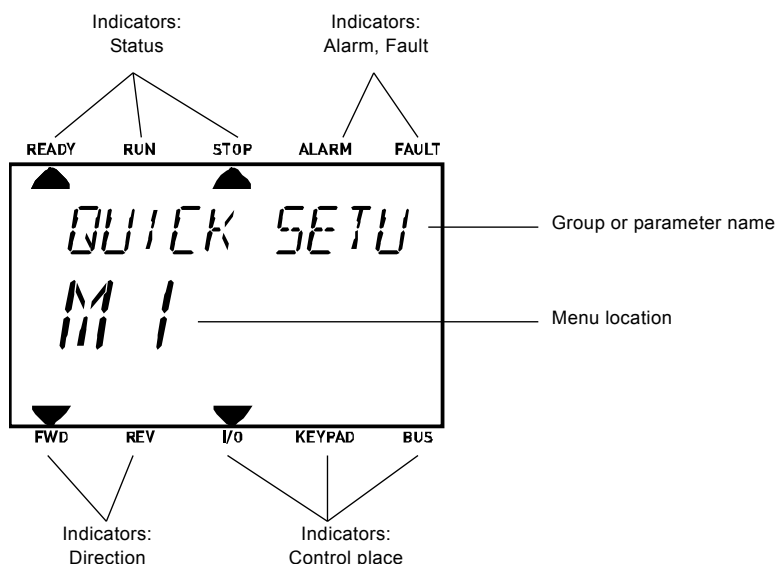

Using the keypad

Editing values

Change value of a parameter following the procedure below:

1. Locate the parameter.
2. Enter the Edit mode by pressing OK.
3. Set new value with the arrow buttons up/down.
You can also move from digit to digit with the arrow buttons left/right if the value is numerical and change then the value with the arrow buttons up/down.
4. Confirm change with OK button or ignore change by returning to previous level with return button.

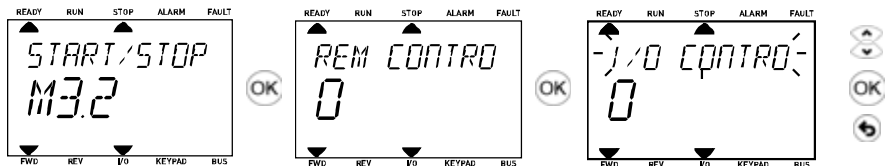

Fig. 66 Editing values

Resetting fault

Instructions for how to reset a fault can be found in 8.2.7.

Function button

The home button is used for four functions:

1. to quickly access the Control page,
2. to easily change between the Local (Keypad) and Remote control places,
3. to change the rotation direction and
4. to quickly edit a parameter value.

Control places

The control place is the source of control where the drive can be started and stopped. Every control place has its own parameter for selecting the frequency reference source. The Local control place is always the keypad. The Remote control place is determined by parameter P3.2.1 (I/O or Fieldbus). The selected control place can be seen on the status bar of the keypad.

Remote control place

I/O A, I/O B and Fieldbus can be used as remote control places. I/O A and Fieldbus have the lowest priority and can be chosen with parameter P3.2.1 (Rem Control Place). I/O B, again, can bypass the remote control place selected with parameter P3.2.1 using a digital input. The digital input is selected with parameter P3.5.1.7 (I/O B Ctrl Force).

Local control

Keypad is always used as control place while in local control. Local control has higher priority than remote control. Therefore, if, for example, bypassed by parameter P3.5.1.7 through digital input while in Remote, the control place will still switch to Keypad if Local is selected. Switching between Local and Remote Control can be done by pressing the FUNCT-button on the keypad or by using the "Local/Remote" (ID211) parameter.

Changing control places

Change of control place from Remote to Local (keypad).

1. Anywhere in the menu structure, push the home button.
2. Using the arrow buttons, select Local/Remote and confirm with the OK button.

3. On the next display, select Local or Remote and again confirm with the OK button.
4. The display will return to the same location as it was when the home button was pushed. However, if the Remote control place was changed to Local (Keypad) you will be prompted for keypad reference.



Fig. 67 Changing control places

Accessing the control page

The Control page is meant for easy operation and monitoring of the most essential values.

1. Anywhere in the menu structure, push the home button.
2. Push the Arrow up or the Arrow down button to select Control page and confirm with the OK button.

3. The control page appears. If keypad control place and keypad reference are selected to be used you can set the Keypad Reference after having pressed the OK button. If other control places or reference values are used the display will show Frequency reference which is not editable.

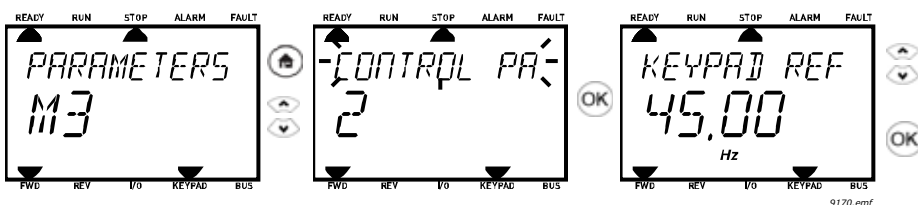

Fig. 68 Accessing Control page

Changing direction

Rotation direction of the motor can quickly be changed by applying the home button.

Note Changing direction command is not visible in the menu unless the selected control place is Local.

1. Anywhere in the menu structure, push the home button.
2. Push the Arrow up or the Arrow down button to select Change direction and confirm with the OK button.
3. Then choose the direction you wish to run the motor to. The actual rotation direction is blinking. Confirm with the OK button.
4. The rotation direction changes immediately and the arrow indication in the status field changes.

Quick edit

Through the Quick edit functionality you can quickly access the desired parameter by entering the parameter's ID number.

1. Anywhere in the menu structure, push the home button.
2. Push the Arrow up or the Arrow down buttons to select Quick Edit and confirm with the OK button.
3. Then enter the ID number of parameter or monitoring value you wish to access. Press OK button to confirm.
4. Requested Parameter/Monitoring value appears on the display (in editing/monitoring mode.)

8.1.7 Fault Tracing

When an unusual operating condition is detected by the AC drive control diagnostics, the drive initiates a notification visible, for example, on the keypad. The keypad will show the code, the name and a short description of the fault or alarm.

The notifications vary in consequence and required action. Faults make the drive stop and require reset of the drive. Alarms inform of unusual operating conditions but the drive will continue running. Info may require resetting but do not affect the functioning of the drive.

For some faults you can program different responses in the application. See parameter group Protections.

The fault can be reset with the Reset button on the control keypad or via the I/O terminal. The faults are stored in the Fault history menu which can be browsed. The different fault codes you will find in the table below.

Note

When contacting distributor or factory because of a fault condition, always write down all texts and codes on the keypad display.

Fault appears

When a fault appears and the drive stops examine the cause of fault, perform the actions advised here and reset the fault as instructed below.

1. With a long (1 s) press on the Reset button on the keypad or
2. By entering the Diagnostics Menu (M4), entering Reset faults (M4.2) and selecting Reset faults parameter.
3. For keypad with LCD display only: By selecting value Yes for the parameter and clicking OK.

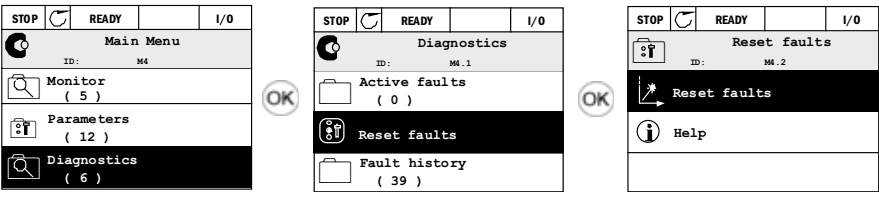

Fig. 69 Diagnostic menu with graphical keypad

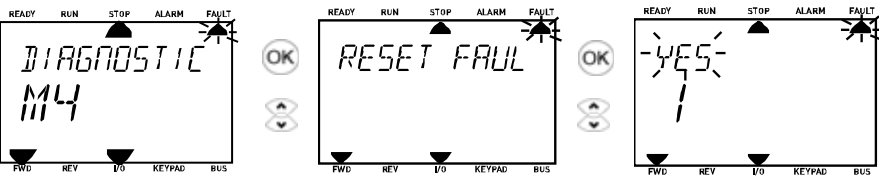

Fig. 70 Diagnostic menu with text keypad

Fault History

In menu M4.3 Fault history you find the maximum number of 40 occurred faults. On each fault in the memory you will also find additional information, see below.

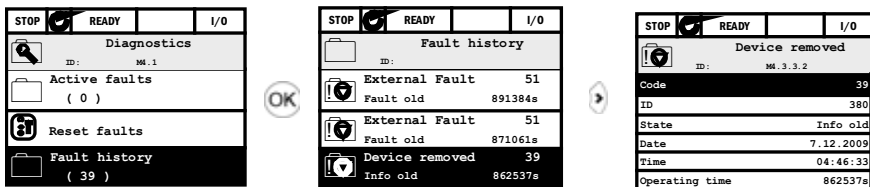

Fig. 71 Fault history menu with graphical keypad

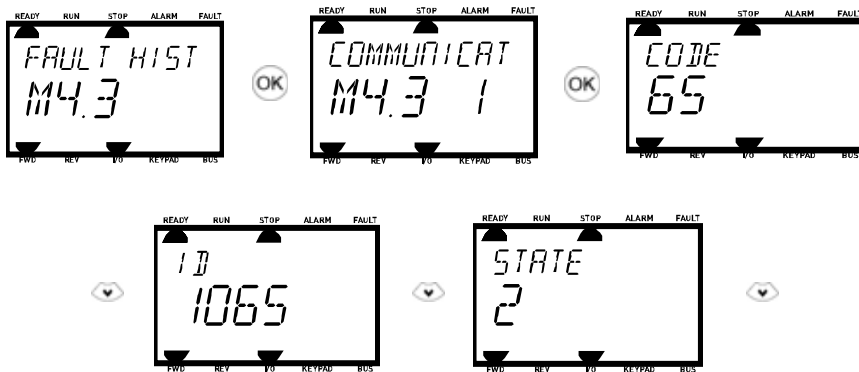

Fig. 72 Fault history menu with text keypad.

Fault codes

| Fault code | Fault ID | Fault name | Possible cause | Remedy |
|-------------------|-----------------|------------------------------|---|---|
| 1 | 1 | Overcurrent (hardware fault) | AC drive has detected too high a current ($>4 \cdot I_H$) in the motor cable: | Check loading. Check motor. Check cables and connections. Make identification run. Check ramp times. |
| | 2 | Overcurrent (software fault) | <ul style="list-style-type: none"> • sudden heavy load increase • short circuit in motor cables • unsuitable motor | |
| 2 | 10 | Overvoltage (hardware fault) | The DC-link voltage has exceeded the limits defined. | Make deceleration time longer. Use brake chopper or brake resistor (available as options). Activate overvoltage controller. Check input voltage. |
| | 11 | Overvoltage (software fault) | <ul style="list-style-type: none"> • too short a deceleration time • brake chopper is disabled • high overvoltage spikes in supply • Start/Stop sequence too fast | |
| 3 | 20 | Earth fault (hardware fault) | Current measurement has detected that the sum of motor phase current is not zero. | Check motor cables and motor. |
| | 21 | Earth fault (software fault) | <ul style="list-style-type: none"> • insulation failure in cables or motor | |
| 5 | 40 | Charging switch | The charging switch is open, when the START command has been given. <ul style="list-style-type: none"> • faulty operation • component failure | Reset the fault and restart. Should the fault re-occur, contact the distributor near to you. |
| 7 | 60 | Saturation | Various causes: <ul style="list-style-type: none"> • defective component • brake resistor short-circuit or overload | Cannot be reset from keypad. Switch off power. DO NOT RE-CONNECT POWER! Contact factory. If this fault appears simultaneously with F1, check motor cables and motor. |

| Fault code | Fault ID | Fault name | Possible cause | Remedy |
|------------|----------|--------------------------|--|---|
| | 600 | | Communication between control board and power unit has failed. | |
| | 601 | | Communication between control board and power unit has interference, but it is still working. | |
| | 602 | | Watchdog has reset the CPU | Reset the fault and restart. Should the fault re-occur, contact the distributor near to you. |
| | 603 | | Voltage of auxiliary power in power unit is too low. | |
| | 604 | | Phase fault: Voltage of an output phase does not follow the reference | |
| | 605 | | CPLD has faulted but there is no detailed information about the fault | |
| | 606 | | Control and power unit software are incompatible | Update software. Should the fault re-occur, contact the distributor near to you. |
| | 607 | | Software version cannot be read. There is no software in power unit. | Update power unit software. Should the fault re-occur, contact the distributor near to you. |
| 8 | | System fault | | |
| | 608 | | CPU overload. Some part of the software (for example application) has caused an overload situation. The source of fault has been suspended | Reset the fault and restart. Should the fault re-occur, contact the distributor near to you. |
| | 609 | | Memory access has failed. For example, retain variables could not be restored. | |
| | 610 | | Necessary device properties cannot be read. | |
| | 614 | | Configuration error. | |
| | 647 | | Software error | |
| | 648 | | Invalid function block used in application. System software and application are not compatible. | Update software. Should the fault re-occur, contact the distributor near to you. |
| | 649 | | Resource overload. Error when loading parameter initial values. Error when restoring parameters. Error when saving parameters. | |
| | 80 | Undervoltage (fault) | DC-link voltage is under the voltage limits defined. | In case of temporary supply voltage break reset the fault and restart the AC drive. Check the supply voltage. If it is adequate, an internal failure has occurred. Contact the distributor near to you. |
| 9 | 81 | Undervoltage (alarm) | <ul style="list-style-type: none"> • most probable cause: too low a supply voltage • AC drive internal fault • defect input fuse • external charge switch not closed NOTE: This fault is activated only if the drive is in Run state. | |
| 10 | 91 | Input phase | Input line phase is missing. | Check supply voltage, fuses and cable. |
| 11 | 100 | Output phase supervision | Current measurement has detected that there is no current in one motor phase. | Check motor cable and motor. |

| Fault code | Fault ID | Fault name | Possible cause | Remedy |
|-------------------|-----------------|--|---|--|
| 12 | 110 | Brake chopper supervision (hardware fault) | No brake resistor installed. Brake resistor is broken. | Check brake resistor and cabling. If these are ok, the chopper is faulty. Contact the distributor near to you. |
| | 111 | Brake chopper saturation alarm | Brake chopper failure. | |
| 13 | 120 | AC drive undertemperature (fault) | Too low temperature measured in power unit's heatsink or board. Heatsink temperature is under -10 °C. | Check the ambient temperature |
| 14 | 130 | AC drive overtemperature (fault, heatsink) | Too high temperature measured in power unit's heatsink or board. Heatsink temperature is over 100 °C. | Check the correct amount and flow of cooling air. Check the heatsink for dust. Check the ambient temperature. Make sure that the switching frequency is not too high in relation to ambient temperature and motor load. |
| | 131 | AC drive overtemperature (alarm, heatsink) | | |
| | 132 | AC drive overtemperature (fault, board) | | |
| | 133 | AC drive overtemperature (alarm, board) | | |
| 15 | 140 | Motor stalled | Motor is stalled. | Check motor and load. |
| 16 | 150 | Motor overtemperature | Motor is overloaded. | Decrease motor load. If no motor overload exists, check the temperature model parameters. |
| 17 | 160 | Motor underload | Motor is underloaded. | Check load. |
| 19 | 180 | Power overload (short-time supervision) | Drive power is too high. | Decrease load. |
| | 181 | Power overload (long-time supervision) | | |
| 25 | 240 | Motor control fault | Start angle identification has failed. | Reset the fault and restart. Should the fault re-occur, contact the distributor near to you. |
| | 241 | | Generic motor control fault. | |
| 26 | 250 | Start-up prevented | Start-up of the drive has been prevented. Run request is ON when a new software (firmware or application), parameter setting or any other file, which has affects the operation of the drive, has been loaded to drive. | Reset the fault and stop the AC drive. Load the software and start the AC drive. |

| Fault code | Fault ID | Fault name | Possible cause | Remedy |
|------------|----------|---------------------------------|--|---|
| 30 | 290 | Safe off | Unstable STO input A (spurious pulses detected). | Check the Safety switch and cabling. Reset the fault and restart. Should the fault re-occur, contact the distributor near to you. |
| | 291 | Safe off | Unstable STO input B (spurious pulses detected). | Check the Safety switch and cabling. Reset the fault and restart. Should the fault re-occur, contact the distributor near to you. |
| | 520 | Safe diagnostic | Diagnostic failure (STO inputs are in different state). | Check the Safety switch and cabling. Reset the fault and restart the drive. Should the fault re-occur, contact the distributor near to you. |
| | 530 | STO fault | STO function activated. Drive is in safe state. | Wait for STO inputs deactivation. Reset the fault and restart. |
| 32 | 312 | Fan cooling | Fan life time is up. | Change fan and reset fan life time counter. |
| 33 | 320 | Fire mode enabled | Fire mode of the drive is enabled. The drive's protections are not in use. | Check the parameter settings |
| 37 | 360 | Device changed (same type) | Option board changed for one previously inserted in the same slot. The board's parameter settings are saved. | Device is ready for use. Old parameter settings will be used. |
| 38 | 370 | Device changed (same type) | Option board added. The option board was previously inserted in the same slot. The board's parameter settings are saved. | Device is ready for use. Old parameter settings will be used. |
| 39 | 380 | Device removed | Option board removed from slot. | Device no longer available. |
| 40 | 390 | Device unknown | Unknown device connected (power unit/option board) | Device no longer available. |
| 41 | 400 | IGBT temperature | IGBT temperature (unit temperature + I_2T) is too high. | Check loading. Check motor size. Make identification run. |
| 44 | 430 | Device changed (different type) | Option board changed or Power unit changed. No parameter settings are saved. | Set the option board parameters again if option board was changed. Set converter parameters again if power unit was changed. |
| 45 | 440 | Device changed (different type) | Option board added. The option board was not previously present in the same slot. No parameter settings are saved. | Set the option board parameters again. |
| 46 | 662 | Real Time Clock | RTC battery voltage level is low and the battery should be changed. | Replace the battery. |
| 47 | 663 | Software updated | Software of the drive has been updated (either the whole software package or application). | No actions needed. |
| 50 | 1050 | AI low fault | At least one of the available analogue input signals has gone below 50% of the defined minimum signal range. Control cable is broken or loose. Signal source has failed. | Change the failed parts. Check the analog input circuit. Check that parameter <i>A11 signal range</i> is set correctly. |

| Fault code | Fault ID | Fault name | Possible cause | Remedy |
|------------|--------------|------------------------------|--|---|
| 51 | 1051 | External Fault | Fault activated by digital input. | Check the digital input or the device connected to it. Check the parameter settings. |
| 52 | 1052 1352 | Keypad communication fault | The connection between the control keypad and frequency converter is broken | Check keypad connection and possible keypad cable |
| 53 | 1053 | Fieldbus communication fault | The data connection between the fieldbus master and fieldbus board is broken | Check installation and fieldbus master. |
| 54 | 1654 | Slot D fault | Defective option board or slot | Check board and slot. |
| | 1754 | Slot E fault | | |
| 57 | 1057 | Identification | Identification run has failed. | Check that motor is connected to the drive. Ensure that there is no load on the motor shaft. Ensure that the start command will not be removed before completion of identification run. |
| 58 | 1058 | Mechanical brake | Actual status of mechanical brake remains different from the control signal for longer than what is defined. | Check the status and connections of the mechanical brake. |
| | 1063 | Quick Stop fault | The Quick stop function is activated | Find the cause for the quick stop activation. After you find it, correct it. Reset the fault and restart the drive. Once found and corrective actions taken, reset the fault and restart the drive. |
| 63 | 1367 | Quick Stop alarm | | |
| 65 | 1065 | PC communication fault | The data connection between the PC and frequency converter is broken | |
| 66 | 1066 | Thermistor fault | The thermistor input has detected an increase of motor temperature | Check motor cooling and load. Check thermistor connection (If thermistor input is not in use it has to be short circuited) |
| 68 | 1301 | Maintenance counter 1 alarm | Maintenance counter has reached the alarm limit. | Carry out the needed maintenance and reset counter. |
| | 1302 | Maintenance counter 2 alarm | Maintenance counter has reached the alarm limit. | Carry out the needed maintenance and reset counter. |
| | 1303 | Maintenance counter 3 alarm | Maintenance counter has reached the alarm limit. | Carry out the needed maintenance and reset counter. |
| | 1304 | Maintenance counter 4 alarm | Maintenance counter has reached the alarm limit. | Carry out the needed maintenance and reset counter. |
| 69 | 1310 | | Non-existing ID number is used for mapping values to Fieldbus Process Data Out. | Check parameters in Fieldbus Data Mapping menu. |
| | 1311 | Fieldbus mapping error | Not possible to convert one or more values for Fieldbus Process Data Out. | The value being mapped may be of undefined type. Check parameters in Fieldbus Data Mapping menu. |
| | 1312 | | Overflow when mapping and converting values for Fieldbus Process Data Out (16-bit). | |
| 76 | 1076 | Start prevented | Start command is active and was blocked in order to prevent unintentional rotation of the motor during the first power-up. | Reset drive to restore the normal operation. The need of restart depends on the parameter settings. |

| Fault code | Fault ID | Fault name | Possible cause | Remedy |
|------------|----------|----------------------------------|--|--|
| 77 | 1077 | >5 connections | Maximum number of 5 simultaneous active fieldbus or PC tool connections supported by the application exceeded. | Remove excessive active connections. |
| 100 | 1100 | Soft fill time-out | The Soft fill function in the PID controller has timed out. The wanted process value was not achieved within time. | Reason might be a pipe burst. |
| 101 | 1101 | Process supervision fault (PID1) | PID controller: Feedback value outside of supervision limits (and the delay if set). | Check settings. |
| 105 | 1105 | Process supervision fault (PID2) | PID controller: Feedback value outside of supervision limits (and the delay if set). | Check settings. |
| 109 | 1109 | Input pressure supervision | Input pressure supervision signal has gone below the alarm limit. | Check the process. Check the parameters Check the input pressure sensor and connections. |
| | 1409 | | Input pressure supervision signal has gone below the fault limit. | |
| 111 | 1315 | Temperature fault 1 | At least one of the selected temperature input signals has reached the alarm limit. | Find the cause of temperature raise. Check the temperature sensor and connections. Check that the temperature input is hard wired if no sensor is connected. See option board manual for further information. |
| | 1316 | | At least one of the selected temperature input signals has reached the fault limit. | |
| 112 | 1317 | Temperature fault 2 | At least one of the selected temperature input signals has reached the fault limit. | See option board manual for further information. |
| | 1318 | | At least one of the selected temperature input signals has reached the fault limit. | |
| 113 | 1113 | Pump running time | In the Multipump system, 1 or more of the pump runtime counters is above a user-specified alarm limit. | Do the necessary maintenance actions, reset the runtime counter and reset the alarm. See Pump running time counters. |
| | 1313 | | In the Multipump system, 1 or more of the pump runtime counters is above a user-specified Fault limit | |
| 300 | 700 | Unsupported | The application is not compatible (it is unsupported). | Replace the application. |
| | 701 | | The option board or the slot is not compatible (it is unsupported). | Remove the option board. |

8.2 Heater (arctic option)

8.2.1 Safety

This manual contains clearly marked cautions and warnings which are intended for your personal safety and to avoid any unintentional damage to the product or connected appliances.

Please read the information included in dangers carefully.

The optional heater allows the drive to operate in low temperature conditions down to -40°C . This option is intended to be installed inside the drive.

Only Grundfos authorized, trained and qualified personnel are allowed to install and maintain this component.

8.2.2 Dangers

Warning



The components of the optional heater are live when the element is connected to mains potential. Coming into contact with this voltage is extremely dangerous and may cause death or severe injury.

Warning



The heater can be used only inside the drive and in combination with only the GrundfosRSI. Before connecting the heater to mains, make sure that the Grundfos RSI drive is closed firmly.

8.2.3 Technical data

The optional heater has to be supplied with single-phase 230V. The thermal element is always supplied and if the drive is connected at -40°C the drive will be heated up until the temperature of -10°C is exceeded. The heating is temperature controlled and an internal fan ensures that the air is equally distributed inside the enclosure.

The integrated relay output (switching capacity: 24VDC / 3A, 250VAC / 3A) can be used to control the power-up of the drive. The contact is closed when the internal temperature is higher than the minimum allowed value for the power-up ($\sim -10^{\circ}\text{C}$). This can be included and manage in the logic of the entire system. A bi-color LED (on the enclosure of this option), shows the status of the drive, ready or not-ready.

Heater connections

| Terminal | Signal | Technical information |
|----------|-----------------------|---|
| L1 | Line | Supply voltage input terminals: |
| N | Neutral | 1AC 230V 50Hz 500 mA |
| X1 | Feedback relay output | Switching capacity: 24VDC / 3A 250VAC /3A |

8.2.4 Fuses

The recommended fuse types for the heater supply voltage are shown in the table below.

| Fuses for heater supply voltage input - 230 VAC | | |
|---|------------------------------|------------------------------|
| gG/gL (IEC 60269-1) 500V | class T (UL& CSA) 600V | class J (UL& CSA) 600V |
| 1A | 1A | 1A |

8.2.5 Mounting instructions: Frame A Example

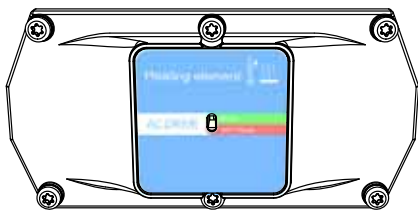

TM06 69899 2916

Fig. 73 Heater option for Frame A

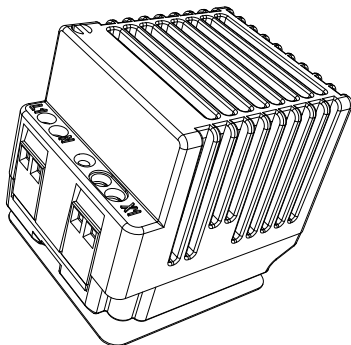

TM06 6948 2916

Fig. 74 Heating element and terminals

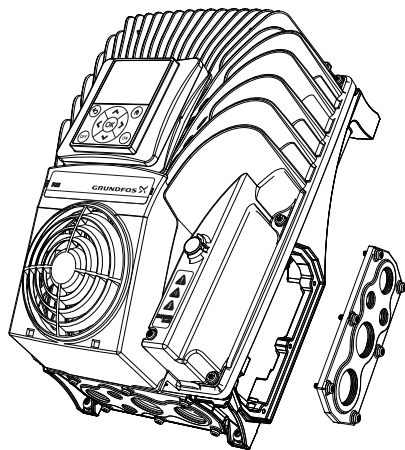

TM06 6957 2916

Fig. 75 Remove the cable entry plate (right side example)

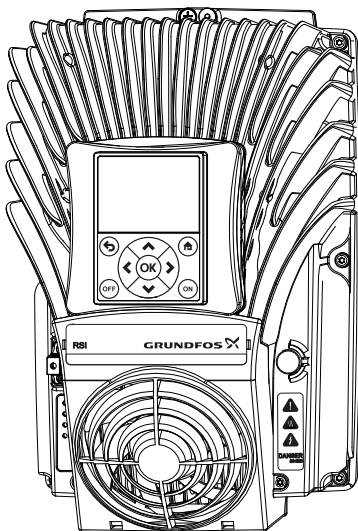

TM06 6952 2916

Fig. 76 Remove the powerhead from the terminal box

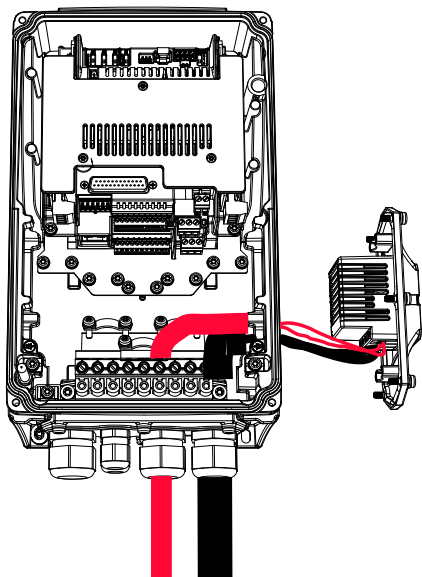

TM06 6951 2916

Fig. 77 Connect the supply voltage (black cable) and the output relay (red cable) to the optional heater through the bottom cable entry plate. Color of the cables is only as example

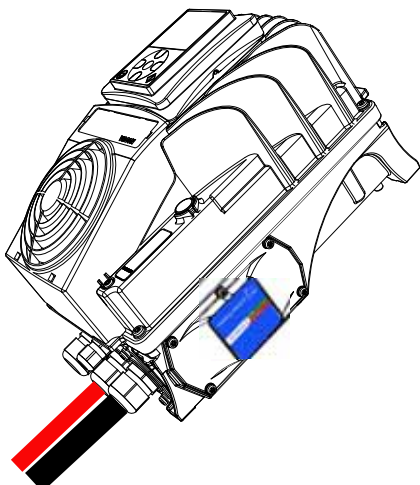

TM06 6953 2916

Fig. 78 Mount the optional heater on the terminal box and then close the powerhead

8.3 Option boards

Grundfos RSI drive family embodies a wide selection of expander boards with which the available I/O of Grundfos RSI frequency converter can be increased and its versatility improved.

There are two board slots (labelled D and E) on the Grundfos RSI control board. To locate the slot, see section 5. *Control unit*. Usually, when the AC drive is delivered from the factory, the control unit doesn't include any option board in the board slots.

The following option boards are supported:

Option boards supported in Grundfos RSI

| Code | Description | Note |
|-------|---|--|
| OPTB1 | Option board with six bidirectional terminals. | With jumper blocks it's possible to use each terminal as digital input or as digital output. |
| OPTB2 | I/O expander board with a thermistor input and two relay outputs. | |
| OPTB4 | I/O expander board with one galvanically isolated analogue input and two galvanically isolated analogue outputs (standard signals 0(4)...20mA). | |
| OPTB5 | I/O expander board with three relay outputs | |
| OPTB9 | I/O expander board with five 42...240 VAC digital inputs and one relay output. | |
| OPTBF | I/O expander board with analogue output, digital output and relay output. | On the OPTBF board, there is one jumper block for selecting the analogue output mode (mA/V). |
| OPTBH | Temperature measurement board with three individual channels. | Supported sensors: PT100, PT1000, NI1000, KTY84-130, KTY84-150, KTY84-131 |
| OPTBK | AS-interface option board | |
| OPTC4 | Lonworks option board | Pluggable connector with screw terminals |
| OPTE3 | Profibus DP option board | Pluggable connector with screw terminals |
| OPTE5 | Profibus DP option board | 9-pin Sub-D terminal |
| OPTE6 | CANopen option board | |
| OPTE7 | DeviceNet option board | |

See the Option boards User's Manual to use and install the option boards.

9. Safe Torque Off

This chapter describes the Safe Torque Off (STO) function which is a functional safety feature present into Grundfos RSI drive products as standard.

9.1 General description

The STO function brings the motor in no-torque-state as defined by 4.2.2.2 of the IEC 61800-5-2: "Power that can cause rotation (or motion in the case of a linear motor) is not applied to the motor. The Power Drive System (Safety Related) will not provide energy to the motor which can generate torque (or force in the case of a linear motor)."

Therefore, the STO function is suitable for applications that rely on the immediate removal of power to the actuator, resulting in an uncontrolled coast to stop (activated by an STO demand). Additional protective measures need to be applied when an application requires a different stop method.

9.2 Warnings

Warning

Designing of safety-related systems requires specialist knowledge and skills. Only qualified people are permitted to install and set up the STO function. The use of STO does not itself ensure safety. *An overall risk evaluation is required for ensuring that the commissioned system is safe.* Safety devices must be correctly incorporated into the entire system which must be designed in compliance with all relevant standards within the field of industry.



Warning

The information in this manual provides guidance on the use of the STO function. This information is in compliance with accepted practice and regulations at the time of writing. However, the end product/system designer is responsible for ensuring that the *end-system* is safe and in compliance with relevant regulations.



Warning

When a permanent magnet motor is used and in case of a multiple IGBT power semiconductor failure, when the STO option energizes the drive outputs to the off state, the drive system may still provide an alignment torque which maximally rotates the motor shaft by $180^\circ/p$ (where p is the number of poles of the motor) before the torque production ceases.



Warning

Electronic means and contactors are not adequate for protection against electric shock. The Safe Torque Off function does not disconnect the voltage or the mains from the drive. Therefore hazardous voltages may still be present on the motor. If electrical or maintenance work has to be carried out on electrical parts of the drive or the motor, the drive has to be completely isolated from the main supply, e.g. using an external supply disconnecting switch (see EN60204-1).



Warning

This safety function corresponds to an uncontrolled stop in accordance with stop category 0 of IEC 60204-1. The STO function does not comply with Emergency Switching Off according to IEC 60204-1 (no galvanic insulation from the Mains in case the motor is stopped).



Warning

The STO function is not a prevention of unexpected start-up. To fulfil those requirements, additional external components are required according to appropriate standards and application requirements.



Warning

In circumstances where external influences (e.g. falling of suspended loads) are present additional measures (e.g. mechanical brakes) may be necessary to prevent any hazard.



Warning

STO shall not be used as a control for starting or stopping the drive.



9.3 Standards

The STO function has been designed for use in accordance with the following standards:

- IEC 61508, Parts 1-7
- EN 61800-5-2
- EN 62061
- ISO 13849-1
- EN 954-1
- IEC 60204-1

The STO function has to be applied correctly to achieve the desired level of operational safety. Four different levels are allowed, depending on the use of the STO signals (see the following table).

| STO inputs | STO feedback | Cat. | PL | SIL |
|--------------------------|--------------|------|----|-----|
| Both dynamically used(*) | Used | 4 | e | 3 |
| Both statically used | Used | 3 | e | 3 |
| Connected in parallel | Used | 2 | d | 2 |
| Connected in parallel | Not used | 1 | c | 1 |

Four different STO levels. (*) see [9.5.1 Safety Capability Cat. 4 / PL e / SIL 3](#)

The same values are calculated for SIL and SIL CL. According to EN 60204-1, the emergency stop category is 0.

The SIL value for the safety related system, operating in high demand/continuous mode, is related to the probability of dangerous failure per hour (PFH), reported in the following table.

| STO inputs | STO feedback | PFH | PFDav | MTTFd (years) | DCavg |
|--------------------------|--------------|--------------|----------|---------------|--------|
| Both dynamically used(*) | Used | 1.2 E-09 1/h | 1.0 E-04 | > 4274 y | HIGH |
| Both statically used | Used | 1.2 E-09 1/h | 1.1 E-04 | > 4274 y | MEDIUM |
| Connected in parallel | Used | 1.2 E-09 1/h | 1.1 E-04 | > 4274 y | MEDIUM |
| Connected in parallel | Not used | 1.5 E-09 1/h | 1.3 E-04 | > 4274 y | NONE |

SIL values. (*) see [9.5.1 Safety Capability Cat. 4 / PL e / SIL 3](#)

Warning



The STO inputs must always be supplied by a safety device.

The power supply of the safety device may be external or taken from the drive (as long as this is compliant with the rating specified for terminal 6).

9.4 The principle of STO

The STO functionality, such as the technical principles and data (wiring examples and commissioning) will be described in this chapter. In Grundfos RSI, the STO function is realized by preventing the propagation of the control signals to the inverter circuit.

The inverter power stage is disabled through redundant disabling paths which start from the two separated and galvanically isolated STO inputs (S1-G1, S2-G2 in fig. 89). In addition, an isolated output feedback is generated to improve the diagnostics of the STO function and to achieve a better safety capability (F+, F- terminals). The values assumed by the STO output feedback are indicated in the following table:

| STO inputs | Operating conditions | STO feedback output | Torque at the motor shaft |
|--------------------------------------|--|---------------------------|----------------------------------|
| Both inputs energized with 24V DC | Normal operation | The feedback must be 0 V | Present (motor on) |
| Power removed from both inputs | STO demand | The feedback must be 24 V | Disabled (motor de-energized) |
| The STO inputs have different values | Failure in demand or due to internal fault | The feedback must be 0 V | Disabled (motor de-energized)(*) |

The diagram below is a conceptual schematic diagram and is presented to illustrate the safety function with relevant safety components only shown.

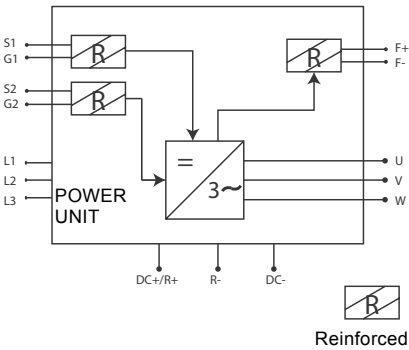

Fig. 79 STO function principle

9.4.1 Technical details

The STO inputs are digital inputs intended for a nominal 24V d.c. input, positive logic (e.g. enabled when high).

| Technical information | Technical values |
|---|---|
| Absolute maximum voltage range | 24 V ± 20 % |
| Typical input current at 24V | 10...15 mA |
| Logic threshold | According to IEC 61131-2 15 V ... 30 V = "1" 0 V ... 15 V = "0" |
| Response time at nominal voltage | |
| Reaction time | < 20 ms |

The reaction time of the STO function is the amount of time which passes from the moment in which the STO is activated until the system is in the Safe State. For Grundfos RSI, the reaction time is 20 ms minimum.

9.5 Connections

To make the STO function available and ready to be used, both the STO jumpers have to be removed. They are located in front of the STO inputs to mechanically prevent the insertion of the STO connector. For the correct configuration, see the following table and the fig. 90.

| Signal | Terminal | Technical information | Data |
|--------------|----------|--|---------------------------|
| STO1 | S1 | Insulated digital input 1 (interchangeable polarity) | 24 V ± 20 % 10...15 mA |
| | G1 | | |
| STO2 | S2 | Insulated digital input 2 (interchangeable polarity) | 24 V ± 20 % 10...15 mA |
| | G2 | | |
| STO feedback | F+ | Insulated digital output for STO feedback (CAUTION! Polarity must be respected) | 24 V ± 20 % 15 mA max. |
| | F- | | |

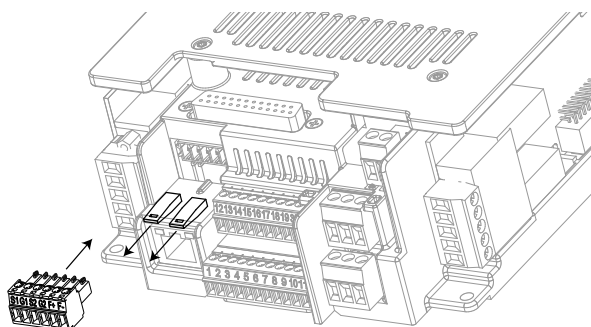

Fig. 80 Removing the STO jumpers

Warning
Make sure that the frequency converter is switched off before cabling.

Warning
Disconnect both the STO jumpers to allow the cabling of the terminals.

Warning
When the STO function is used, the IP-class of the drive may not be reduced below IP54. The IP-class of drive is IP66. It can be reduced by the wrong use of the cable entry plates or the cable glands.

The following examples show the basic principles for wiring the STO inputs and the STO output feedback. Local standards and regulations should be always followed in the final design.

TM06 7149 2916

9.5.1 Safety Capability Cat. 4 / PL e / SIL 3

For this safety capability, an external safety device must be installed. This must be used to dynamically activate the STO inputs and to monitor the STO output feedback.

The STO inputs are dynamically used when they do not commute together (static use), but according to the following picture (where the inputs are released with delay in turn). The dynamic use of the STO inputs allows detecting faults that may otherwise accumulate.

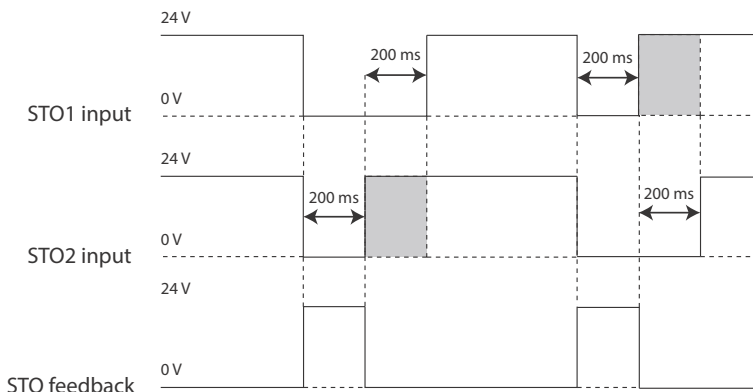

TM06 7148 2916

Fig. 81

Warning



An emergency push button connected to the STO inputs does not assure the same quality, because no fault detection is performed at a sufficient frequency (once a day is recommended).

Warning



The external safety device, which forces the STO inputs and evaluates the STO output feedback, has to be a safe device and it has to fulfil the requirements of the specific application.

Warning



A simple switch cannot be used in this case!

The picture below shows an example of connection for the STO function. The external device has to be connected with 6 wires to the drive.

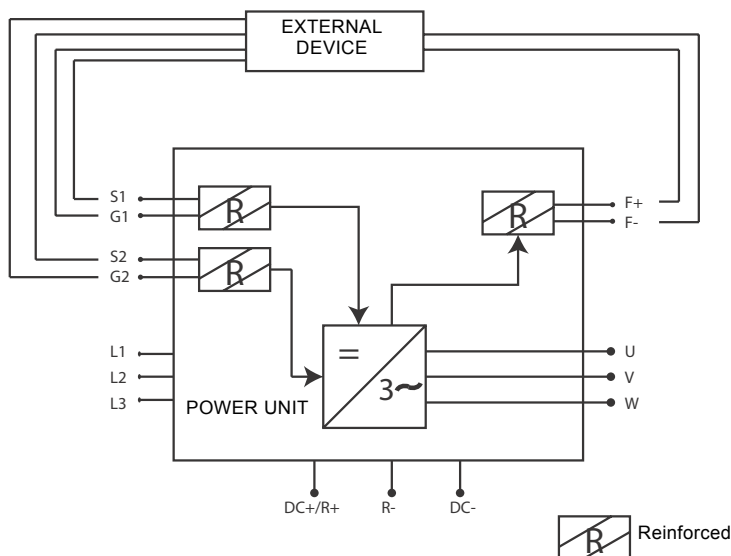

TM06 7152 2916

Fig. 82 STO example with automatic monitoring of the feedback and both STO inputs used

The external device has to monitor the STO function in accordance with the section [9.4 The principle of STO](#). The device has to periodically de-energize the STO inputs and it has to verify that the STO output feedback assumes the expected value.

Any difference between the expected and the real value has to be considered as a failure and has to drive the system into a Safe State. In case of failure, check the wiring. If the fault recognized by the external safety device persists, the drive will have to be replaced/repaired.

9.5.2 Safety Capability Cat. 3 / PL e / SIL 3

The safety capability is reduced to Cat. 3 / PL e / SIL 3 if the STO inputs are statically used (which means they are forced to commute together).

Both STO inputs and the STO feedback have to be used. The same warnings and cabling instruction as 9.5.1 Safety Capability Cat. 4 / PL e / SIL 3 apply.

9.5.3 Safety Capability Cat. 2 / PL d / SIL 2

The safety capability is reduced to Cat. 2 / PL d / SIL 2 if the STO inputs are connected in parallel (no redundancy of the STO inputs).

The STO feedback has to be used. The same warnings as 9.5.1 apply. The picture below shows an example of connection for the STO function. The external device has to be connected with 4 wires to the drive.

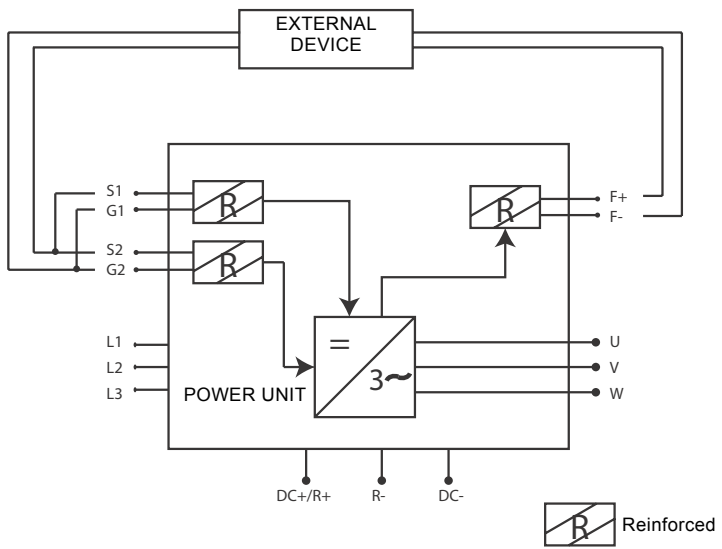

TM06 7145 2916

Fig. 83 STO Example with automatic monitoring of the feedback and STO inputs connected in parallel

9.5.4 Safety Capability Cat. 1 / PL c / SIL 1

Without any automatic monitoring of STO output feedback, the safety capability is reduced to Cat. 1 / PL c / SIL 1. The STO inputs (which can be connected in parallel) must be supplied by a safety push button or a safety relay.



Warning

The choice of using the STO inputs (without the automatic monitoring of the output feedback) does not allow other safety capabilities to be achieved.



Warning

The standards for functional safety require that functional proof tests are performed on the equipment at user-defined intervals. Therefore, this safety capability can be achieved, as long as the STO function is manually monitored at the frequency determined by the specific application (once a month can be acceptable).



Warning

This safety capability can be achieved by connecting in parallel the STO inputs externally and by ignoring the use of the STO output feedback.

The picture below shows an example of connection for the STO function. A switch (a safety push button or a safety relay) may be connected with 2 wires to the drive.

When the contacts of the switch are opened, the STO is demanded, the drive indicates F30 (= "Safe Torque Off") and the motor stops by coasting.

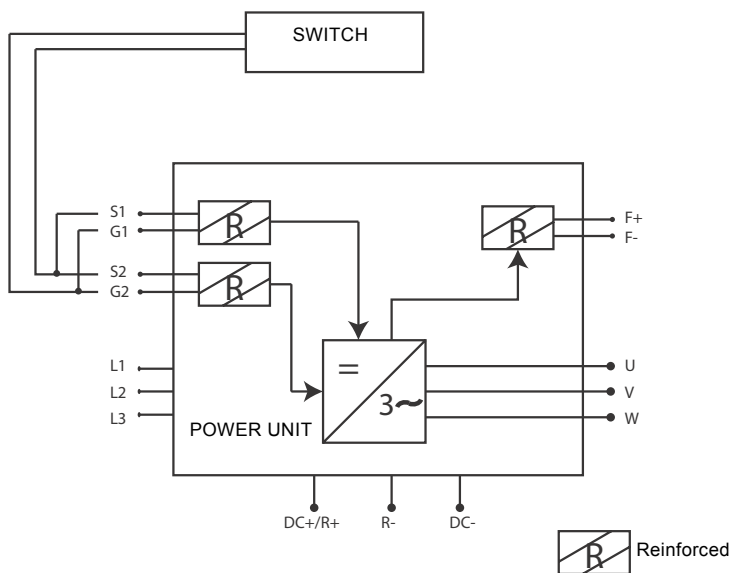

TM06 7146 2916

Fig. 84 STO example without automatic monitoring of the feedback and STO inputs connected in parallel

9.6 Commissioning

9.6.1 General wiring instructions



Warning
Protect the STO cabling with a shielding or an enclosure to exclude external damage.



Warning
Wires ferrules are highly recommended for all STO signals (inputs and feedback).

The wiring should be done according to the general wiring instructions for the specific product. A shielded cable is required. In addition, the voltage drop from the supply point to the load shall not exceed 5% [EN 60204-1 part 12.5].

9.6.2 Checklist for commissioning

Follow the checklist shown in the table below for the steps required to use the STO function.

| | |
|--------------------------|--|
| <input type="checkbox"/> | Carry out a risk assessment of the system to ensure that the use of the STO function is safe and according to the local regulations |
| <input type="checkbox"/> | Include in the assessment an examination of whether the use of external devices, such as a mechanical brake, are required. |
| <input type="checkbox"/> | Check if the switch (if used) has been chosen according to the required safety performance target (SIL/PL/Category) set during the risk evaluation |
| <input type="checkbox"/> | Check if the external device for automatic monitoring of the STO output feedback (if used) has been chosen in accordance with the specific application |
| <input type="checkbox"/> | Check if the reset function with the STO function (if used) is edge sensitive. |
| <input type="checkbox"/> | The shaft of a permanent magnet motor might, in an IGBT fault situation, still provide energy before the torque production ceases. This may result in a jerk of max. 180° electrically. Ensured that the system is designed in such a way that this can be accepted. |
| <input type="checkbox"/> | Check if the degree of protection of the enclosure is at least IP54. See paragraph 9.5. |
| <input type="checkbox"/> | Check if the recommendations on EMC for cables have been followed. |
| <input type="checkbox"/> | Check if the system has been designed in such a way that enabling of the drive through STO inputs will not lead to an unexpected start of the drive. |
| <input type="checkbox"/> | Check if only approved units and parts have been used. |
| <input type="checkbox"/> | Set up a routine to ensure that the functionality of the STO function is being checked at regular intervals. |

The following table indicates examples of cables to be used.

| STO feedback | Cable size |
|---|-------------------------------------|
| STO feedback automatically monitored by an external safety device | 3 x (2 + 1) x 0,5 mm ² * |
| STO feedback ignored, simply safety device (switch) used | 2 x (2 + 1) x 0,5 mm ² |

Cable types required to meet the standards.

* Additional wires are needed for restarting the drive after each STO demand.

9.7 Parameters and fault tracing

There are no parameters for the STO function itself.

Warning



Before testing the STO function, make sure that the checklist ([9.6.2 Checklist for commissioning](#)) is inspected and completed.

Warning



When STO function activates, the drive always generates a fault ("F30") and the motor stops by coasting.

Warning



In the application the STO state can be indicated using a digital output.

To re-enable motor operation, after the STO state, it is necessary to perform the following steps:

- Release the switch or the external device ("F30" is displayed even after this has been released).
- Reset the fault (through a digital input or from the keypad).
- It is possible that a new start command is required for the restart (depending on the application and your parameter settings).

9.8 Maintenance and diagnostics

Warning



If any service or repair is to be conducted on the drive installed, please inspect the checklist given in section [9.6.2 Checklist for commissioning](#)

Warning



During maintenance breaks, or in case of service/repair, ALWAYS make sure that the STO function is available and fully functional by testing it.

The STO function or the STO input/output terminals do not need any maintenance.

The following table shows faults that may be generated by the software that monitors the hardware related to the STO safety function. If you detect any failure in safety functions, including STO, contact your local Grundfos supplier.

| Fault Code | Fault | Cause | Correction |
|------------|-----------------|--|---------------|
| 30 | Safe Torque Off | STO inputs in a different state or both de-energized | Check cabling |

10. Disposal

This product or parts of it must be disposed of in an environmentally sound way:

1. Use the public or private waste collection service.
2. If this is not possible, contact the nearest Grundfos company or service workshop.

Subject to alterations.

Declaration of conformity

GB: EU declaration of conformity

We, Grundfos, declare under our sole responsibility that the product RSI, to which the declaration below relates, is in conformity with the Council Directives listed below on the approximation of the laws of the EU member states.

CZ: Prohlášení o shodě EU

My firma Grundfos prohlašujeme na svou plnou odpovědnost, že výrobek RSI, na který se toto prohlášení vztahuje, je v souladu s níže uvedenými ustanoveními směrnice Rady pro sblížení právních předpisů členských států Evropského společenství.

DK: EU-overensstemmelseserklæring

Vi, Grundfos, erklærer under ansvar at produktet RSI som erklæringen nedenfor omhandler, er i overensstemmelse med Rådets direktiver der er nævnt nedenfor, om indbyrdes tilnærmelse til EU-medlemsstaternes lovgivning.

ES: Declaración de conformidad de la UE

Grundfos declara, bajo su exclusiva responsabilidad, que el producto RSI al que hace referencia la siguiente declaración cumple lo establecido por las siguientes Directivas del Consejo sobre la aproximación de las legislaciones de los Estados miembros de la UE.

FR: Déclaration de conformité UE

Nous, Grundfos, déclarons sous notre seule responsabilité, que le produit RSI, auquel se réfère cette déclaration, est conforme aux Directives du Conseil concernant le rapprochement des législations des États membres UE relatives aux normes énoncées ci-dessous.

HR: EU deklaracija sukladnosti

Mi, Grundfos, izjavljujemo s punom odgovornošću da je proizvod RSI, na koja se izjava odnosi u nastavku, u skladu s direktivama Vijeća dolje navedenih o usklađivanju zakona država članica EU-a.

IT: Dichiarazione di conformità UE

Grundfos dichiara sotto la sua esclusiva responsabilità che il prodotto RSI, al quale si riferisce questa dichiarazione, è conforme alle seguenti direttive del Consiglio riguardanti il ravvicinamento delle legislazioni degli Stati membri UE.

LV: ES atbilstības deklarācija

Sabiedrība Grundfos ar pilnu atbildību paziņo, ka produkts RSI, uz kuru attiecas tālāk redzamā deklarācija, atbilst tālāk norādītajām Padomes direktīvām par ES dalībvalstu normatīvo aktu tuvināšanu.

PL: Deklaracja zgodności UE

My, Grundfos, oświadczamy z pełną odpowiedzialnością, że nasz produkt RSI, którego deklaracja niniejsza dotyczy, jest zgodny z następującymi dyrektywami Rady w sprawie zbliżenia przepisów prawnych państw członkowskich.

RO: Declarația de conformitate UE

Ni, Grundfos declarăm pe propria răspundere că produsul RSI, la care se referă această declarație, este în conformitate cu Directivele de Consiliu specificate mai jos privind armonizarea legilor statelor membre UE.

RU: Декларация о соответствии нормам ЕС

Мы, компания Grundfos, со всей ответственностью заявляем, что изделие RSI, к которому относится нижеприведенная декларация, соответствует нижеприведенным Директивам Совета Евросоюза о тождественности законов стран-членов ЕС.

SI: Izjava o skladnosti EU

V Grundfosu s polno odgovornostjo izjavljamo, da je izdelek RSI, na katerega se spodnja izjava nanaša, v skladu s spodnjimi direktivami Sveta o približevanju zakonodaje za izenačevanje pravnih predpisov držav članic EU.

TR: AB uygunluk bildirgesi

Grundfos olarak, aşağıdaki bildirim konusunu olan RSI ürünlerinin, AB üye ülkelerinin direktiflerini yakınılaştırmaya yönelik durumun aşağıdaki Konsey Direktifleriyle uyumlu olduğunu ve bunlarla ilgili olarak tüm sorumluğun bize ait olduğunu beyan ederiz.

CN: 欧盟符合性声明

我们，格兰富，在我们的全权责任下声明，产品 RSI 系列，其制造和性能完全符合以下所列欧盟委员会指令。

BG: Декларация за съответствие на ЕО

Ние, фирма Grundfos, заявяваме с пълна отговорност, че продуктът RSI, за който се отнася настоящата декларация, отговаря на следните директиви на Съвета за уеднаквяване на правните разпоредби на държавите-членци на ЕО.

DE: EU-Konformitätserklärung

Wir, Grundfos, erklären in alleiniger Verantwortung, dass das Produkt RSI, auf das sich diese Erklärung bezieht, mit den folgenden Richtlinien des Rates zur Angleichung der Rechtsvorschriften der EU-Mitgliedsstaaten übereinstimmt.

EE: EÜvastavusdeklaratsioon

Meie, Grundfos, kinnitame, kinnitame ja kanname ainuiskikulist vastutust selle eest, et toode RSI, mille kohta all olev deklaratsioon käib, on kooskõlas Nõukogu Direktiividega, mis on nimetatud all pool vastavalt vastuvõetud õigusaktidele ühtlustamise kohta EU liikmesriikides.

FI: EU-vaatimustenmukaisuusvakuutus

Grundfos vakuuttaa omalla vastuullaan, että tuote RSI, jota tämä vakuutus koskee, on EU:n jäsenvaltioiden lainsäädännön lähentämiseen tähtäviin Euroopan neuvoston direktiivien vaatimusten mukainen seuraavasti.

GR: Δήλωση συμμόρφωσης ΕΕ

Εμείς, η Grundfos, δηλώνουμε με αποκλειστικά δική μας ευθύνη ότι το προϊόν RSI, στο οποίο αναφέρεται η παρακάτω δήλωση, συμμορφώνεται με τις παρακάτω Οδηγίες του Συμβουλίου περί προσέγγισης των νομοθεσιών των κρατών μελών της ΕΕ.

HU: EU megfelelőségi nyilatkozat

Mi, a Grundfos vállalat, teljes felelősséggel kijelentjük, hogy a(z) RSI termék, amelyre az alábbi nyilatkozat vonatkozik, megfelel az Európai Unió tagállamainak jogi irányelveit összeshangoló tanács alábbi előírásainak.

LT: ES atitikties deklaracija

Mes, Grundfos, su visa atsakomybe pareiškiamo, kad produktas RSI, kuriam skirta ši deklaracija, atitinka žemiau nurodytas Tarybos Direktyvas dėl ES šalių narių įstatymų suderinimo.

NL: EU-conformiteitsverklaring

Wij, Grundfos, verklaren geheel onder eigen verantwoordelijkheid dat product RSI, waarop de onderstaande verklaring betrekking heeft, in overeenstemming is met de onderstaande Richtlijnen van de Raad inzake de onderlinge aanpassing van de wetgeving van de EU-landstaten.

PT: Declaração de conformidade UE

A Grundfos declara sob sua única responsabilidade que o produto RSI, ao qual diz respeito a declaração abaixo, está em conformidade com as Directivas do Conselho sobre a aproximação das legislações dos Estados Membros da UE.

RS: Deklaracija o uskladenosti EU

Mi, kompanija Grundfos, izjavljujemo pod punom vlastitom odgovornošću da je proizvod RSI, na koji se odnosi deklaracija ispod, u skladu sa dole prikazanim direktivama Saveta za usklađivanje zakona država članica EU.

SE: EU-försäkran om överensstämmelse

Vi, Grundfos, försäkrar under ansvar att produkten RSI, som omfattas av nedanstående försäkran, är i överensstämmelse med de rättsdirektiv som inbördes närmade till EU-medlemsstaternas lagstiftning som listas nedan.

SK: ES vyhlásenie o zhode

My, spoločnosť Grundfos, vyhlasujeme na svoju plnú zodpovednosť, že produkt RSI, na ktorý sa vyhlásenie uvedené nižšie vzťahuje, je v súlade s ustanoveniami nižšie uvedených smerníc Rady pre zblíženie právnych predpisov členských štátov EU.

UA: Декларация відповідності директивам ЕО

Ми, компанія Grundfos, під нашу одноосібну відповідальність заявляємо, що виріб RSI, до якого відноситься нижченаведена декларация, відповідає директивам ЕО, переліченим нижче, щодо тотожності законів країн-членів ЄС.

JP: EU 適合宣言

Grundfos は、その責任の下に、RSI 製品が EU 加盟諸国の法規に開連する、以下の評議会指令に適合していることを宣言します。

KO: EU

Grundfos

RSI

EU

BS: Izjava o usklađenosti EU

Mi, kompanija Grundfos, izjavljujemo pod vlastitom odgovornošću da je proizvod RSI, na koji se odnosi izjava ispod, u skladu sa niže prikazanim direktivama Vijeća o usklađivanju zakona država članica EU.

ID: Deklarasi kesesuaian Uni Eropa

Kami, Grundfos, menyatakan dengan tanggung jawab kami sendiri bahwa produk RSI, yang berkaitan dengan pernyataan ini, sesuai dengan Petunjuk Dewan serta sedapat mungkin sesuai dengan hukum negara-negara anggota Uni Eropa.

MK: Декларација за сообразност на ЕУ

Ние, Grundfos, изјавуваме под целосна одговорност дека производот RSI, на кого се однесува долунаведената декларација, е во согласност со овие директиви на Советот за приближување на законите на земјите-членки на ЕУ.

NO: EUs samsvarsærklæring

Vi, Grundfos, erklærer under vårt eneansvar at produktet RSI, som denne erklæringen gjelder, er i samsvar med Det europeiske råds direktiver om tilnærming av forordninger i EU-landene.

TH: คำประกาศความสอดคล้องตามมาตรฐาน EU

เราในนามของบริษัท Grundfos

ขอประกาศภายใต้ความรับผิดชอบของเราแต่เพียงผู้เดียวว่าผลิตภัณฑ์ RSI ซึ่งเกี่ยวข้องกับคำประกาศนี้มีความสอดคล้องกับระเบียบคำสั่งตามรายการด้านล่างนี้ของสหราชอาณาจักรด้วยค่าประมาณตามกฎหมายของรัฐที่เป็นสมาชิก EU

VI: TUYÊN BỐ TUÂN THỦ EU

Chúng tôi, Grundfos, tuyên bố trong phạm vi trách nhiệm duy nhất của mình rằng sản phẩm RSI mà tuyên bố dưới đây có liên quan tuân thủ các Chỉ thị Hội đồng sau về việc áp dụng luật pháp của các nước thành viên EU.

KZ: Сәйкестік жөніндегі ЕО декларациясы

Біз, Grundfos, ЕО мүше елдерінің заңдарына жақын төменде көрсетілген Кеңес директиваларына сәйкес төмендегі декларацияға қатысты RSI өнімі біздің жеке жауапкершілігімізде екенін мәлімдейміз.

MY: Perisytiharan keakuran EU

Kami, Grundfos, mengisytiharkan di bawah tanggungjawab kami semata-mata bahawa produk RSI, yang berkaitan dengan perisytiharan di bawah, akur dengan Perintah Majlis yang disenaraikan di bawah ini tentang penghampiran undang-undang negara ahli EU.

AR: إقرار مطابقة EU

RSI، نحن، Grundfos، بمقتضى مسؤوليتنا الفردية بأن المنتج الذي يختص به الإقرار أعلاه، يكون مطابقاً لتوجيهات المجلس المذكورة أدناه بشأن التقريب بين قوانين الدول أعضاء المجموعة الأوروبية/الاتحاد الأوروبي (EU).

TW: EU 合格聲明

基爾蓋根據我們唯一的責任，茲聲明與以下聲明相關之 RSI 產品，符合下列近似 EU 會員國法律之議會指令。

AL: Deklara e konformitetit të BE

Ne, Grundfos, deklarojmë vetëm nën përgjegjësinë tonë se produkti RSI, me të cilin ka lidhje kjo deklarata, është në pajtim me direktivat e Këshillit të renditura më poshtë për përfarimin e ligjeve të shteteve anëtare të BE-së.

- Low Voltage Directive (2014/35/EU)
Standards used:
EN 61800-5-1:2007
- EMC Directive (2014/30/EU)
Standards used:
EN 61800-3:2004+A1:2012
- Machinery Directive 2006/42/EC
Standards used:
EN 61800-5-2:2007
EN ISO 13849-1:2008+AC:2009
EN 62061:2005+AC:2010

This EU declaration of conformity is only valid when published as part of the Grundfos safety instructions (publication number 99095689 0716).

Bjerringbro, 5/July/2016



Svend Aage Kaae
Director
Grundfos Holding A/S
Poul Due Jensens Vej 7
8850 Bjerringbro, Denmark

Person authorised to compile the technical file and empowered to sign the EU declaration of conformity.