



Flygt Submersible Pumps

AVAILABLE FOR RENTAL AND SALE

FLYGT
a xylem brand

BIBO 2800 Series Dewatering Pumps

Flygt BIBO pumps cover medium, high, and super-high pressures to handle almost any application. They still have the iconic look; a shape that means stability and robustness. We took our proven hydraulic design and merged it with features that once set the standard in dewatering pumping.

BS/KS 2830

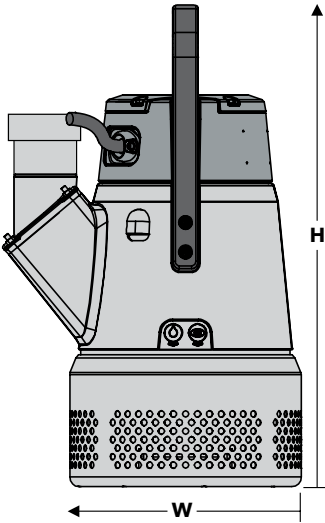

Model number: 2830.180
 Motor rating: 5.9 HP @ 3475 RPM
 Voltage (3Ø): 208V 230V 460V 575V
 Full load amps: 17A 15A 7.3A 5.8A
 Versions: 3" High head Imp. Code B253
 4" Standard Imp. Code K236, B228
 Hose connection: Male NPT
 Pump dimensions: 14 1/2" W (max.) x 30" H (max.)
 Max. weight (lbs.): 119
 Description: Aluminum and stainless steel construction; open non-clog (K) or extra wear resistant (B) closed impellers, rests on bottom strainer.
 Options: Warm liquid 70°C version available.

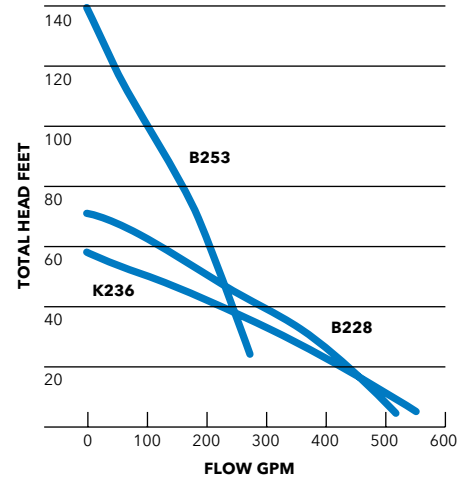

BS/KS 2840

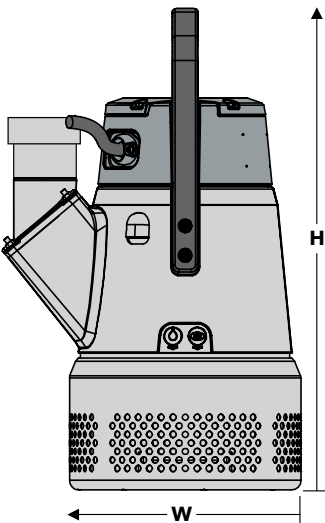

Model number: 2840.180
 Motor rating: 1Ø: 6 HP @ 3480 RPM
 3Ø: 8.9 HP @ 3495 RPM
 Voltage (1Ø): 230V
 Full load amps: 25A
 Voltage (3Ø): 208V 230V 460V 575V
 Full load amps: 24A 22A 11A 8.5A
 Versions: 3" High head Imp. Code B252 (1Ø), B253 (3Ø)
 4" Standard Imp. Code B227 (1Ø), K236, B228 (3Ø)
 Hose connection: Male NPT
 Pump dimensions: 11 1/2" W (max.) x 30" H (max.)
 Max. weight (lbs.): 123
 Description: Aluminum and stainless steel construction; open non-clog (K) or extra wear resistant (B) closed impellers, rests on bottom strainer.
 Options: Warm liquid 70°C version available.

