



Flygt Submersible Pumps

AVAILABLE FOR RENTAL AND SALE



www.motralec.com / service-commercial@motralec.com / 01.39.97.65.10

Flygt BIBO 2800 Series

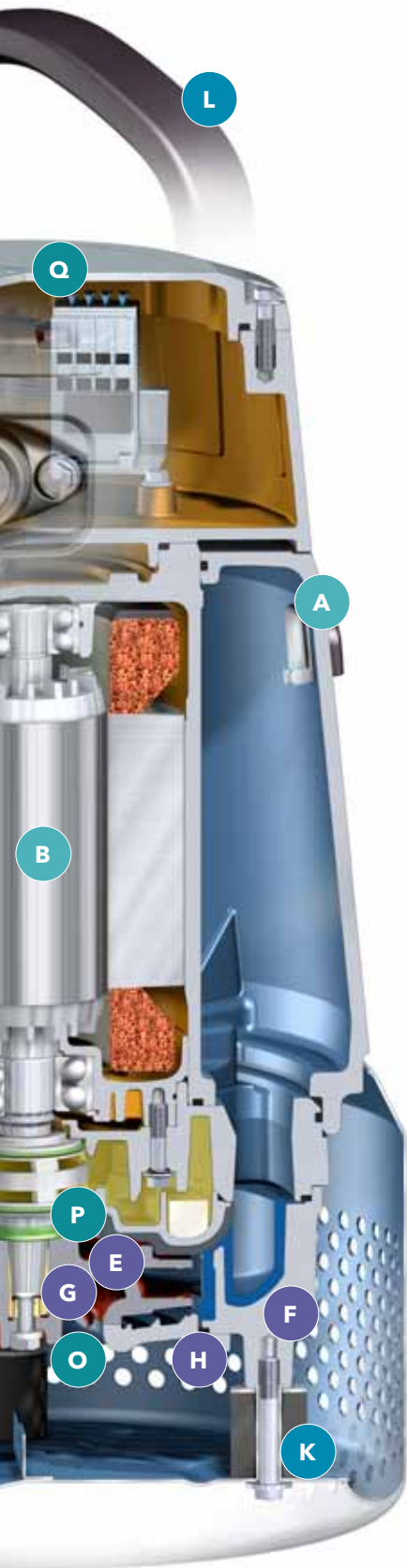

Last pump standing

You need your pump to keep pumping; in all environments and in all situations. We know what you need and here are some features that experience tells us you're going to like.

- I Wide base and low discharge**
More stability with less risk of the pump tipping over.
- J Sealed off terminal board**
To protect the pump from consequential damage.
- K Strainer bottom with shock absorbers**
Rubber shock absorbers provide impact protection. Strainer holes prevent obstruction due to large debris while the strainer bottom offers an easy-to-grip design with less risk of a drop.
- L Adjustable handle**
Change height to suit lifting device.
- M Protected cable entry**
Less risk of cable damage when handling the pump.
- N Flygt SUBCAB®**
Superior mechanical strength for dependable long-term sealing in the cable entry.

Service with a smile

You want to spend as little time servicing your pumps as possible. Thanks to easy impeller adjustment and few parts, the Flygt BIBO series brings a high level of simplicity to service. Once you know one pump in the series you'll know them all.

- O Single impeller-adjustment screw**
Fast and easy impeller-adjustment restores clearances to near-original condition, thereby increasing pump performance.
- P Plug-in™ seal with aluminum housing**
The unique aluminum one-piece Plug-in™ seal provides a perfect fit and fast, simple replacement. It features Active Seal™ for zero leakage into the stator housing and uses superior quality seal ring materials.
- Q Inspection cover**
No need to loosen the top from the stator with fast access to the junction box.
- R External inspection and oil plugs**
Quick service check, less downtime, no unnecessary disassembly.



Air valve



External inspection



Spin-Out™



Aluminium Plug-In™ Seal



Single adjustment screw

BIBO 2800 Series Dewatering Pumps

Flygt BIBO pumps cover medium, high, and super-high pressures to handle almost any application. They still have the iconic look; a shape that means stability and robustness. We took our proven hydraulic design and merged it with features that once set the standard in dewatering pumping.

BS/KS 2830

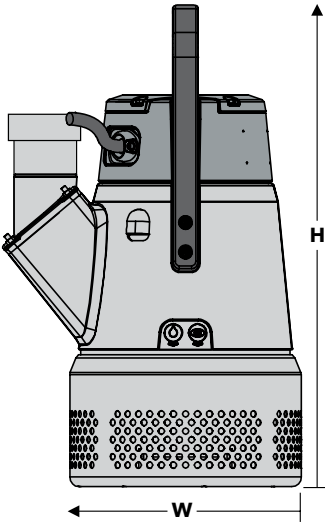

Model number: 2830.180
 Motor rating: 5.9 HP @ 3475 RPM
 Voltage (3Ø): 208V 230V 460V 575V
 Full load amps: 17A 15A 7.3A 5.8A
 Versions: 3" High head Imp. Code B253
 4" Standard Imp. Code K236, B228
 Hose connection: Male NPT
 Pump dimensions: 14 1/2" W (max.) x 30" H (max.)
 Max. weight (lbs.): 119
 Description: Aluminum and stainless steel construction; open non-clog (K) or extra wear resistant (B) closed impellers, rests on bottom strainer.
 Options: Warm liquid 70°C version available.

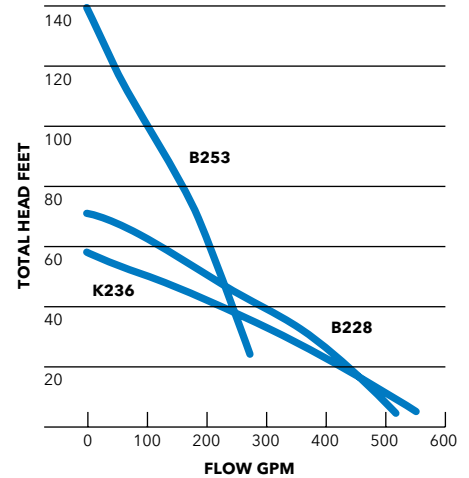

BS/KS 2840

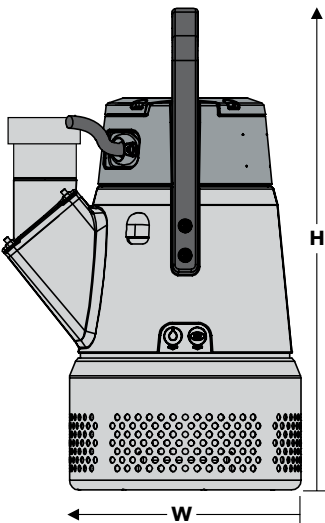

Model number: 2840.180
 Motor rating: 1Ø: 6 HP @ 3480 RPM
 3Ø: 8.9 HP @ 3495 RPM
 Voltage (1Ø): 230V
 Full load amps: 25A
 Voltage (3Ø): 208V 230V 460V 575V
 Full load amps: 24A 22A 11A 8.5A
 Versions: 3" High head Imp. Code B252 (1Ø), B253 (3Ø)
 4" Standard Imp. Code B227 (1Ø), K236, B228 (3Ø)
 Hose connection: Male NPT
 Pump dimensions: 11 1/2" W (max.) x 30" H (max.)
 Max. weight (lbs.): 123
 Description: Aluminum and stainless steel construction; open non-clog (K) or extra wear resistant (B) closed impellers, rests on bottom strainer.
 Options: Warm liquid 70°C version available.

