

Flygt 2125.181

DEWATERING PUMP

60 Hz

Tough pumps for dewatering

The Flygt dewatering pumps from Xylem are designed for tough operating conditions. The pumps are ideal for applications in which the water or liquid contains high amounts of clay, stone chips, drilling fines etc, or to pump heavy sediment from tanks, sumps and containers.

These portable and robust aluminium pumps are found in operation in all types of dewatering applications.

Our dewatering pumps are backed by an outstanding support and world-wide presence. Operating in over 150 countries, we bring many years of experience to bear in order to keep your business moving.



FLYGT
a xylem brand

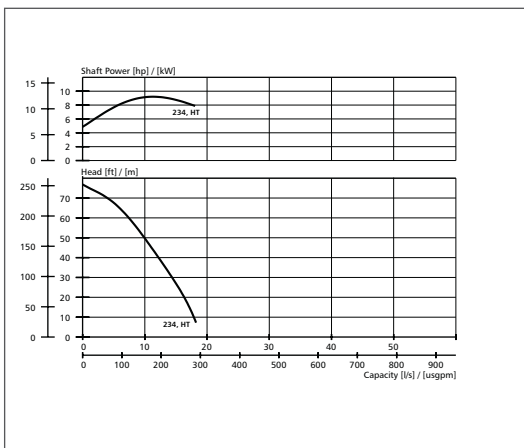
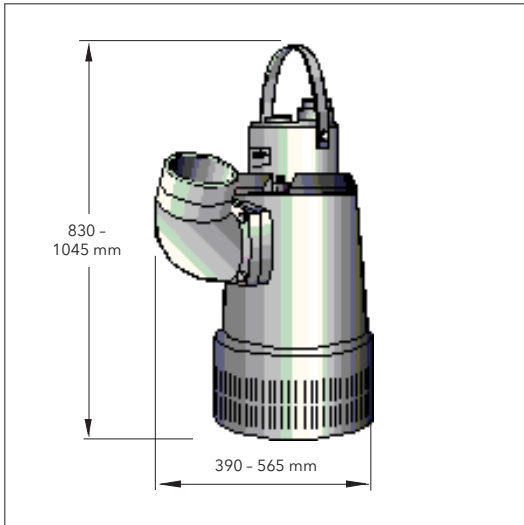

Voltage (V)	Rated current (A)	Starting current (A)
230	32	203
460	16	114
575	13	91
600	12	85

Flygt 2125.181

Submersible pump for dewatering building yards, draining water in flooded areas, and other similar applications.

Denomination

Product code	2125.181
Installation	S
Impeller characteristics	HT
Discharge connection	3", 4", 5", 6"

Process data

Liquid temperature	max +40° C
Depth of immersion	max 20 m
The pH of the pumped liquid	pH 5 - 8
Liquid density	max 1100 kg/m ³
Strainer hole size	6 mm x 50 mm

Motor data

Squirrel cage 3-phase induction motor.	
Frequency	60 Hz
Insulation class	H (+180° C)
Voltage variation	
- continuously running	max ± 5%
- intermittent running	max ± 10%
Voltage imbalance between phases	max 2%
No. of starts/hour	max 15

Monitoring equipment

Thermal contacts.

Cable

Direct-on-line and Y/D start	SUBCAB®
------------------------------	---------

Materials

Outer casing	Aluminium
Impeller	High chrome alloyed white cast iron
Wear parts	Nitrile rubber
Stator housing	Aluminium
Strainer	Galvanized steel
Shaft	Stainless steel
O-rings	Nitrile rubber

Mechanical face seals

Inner	Corrosion resistant cemented carbide
Outer	Corrosion resistant cemented carbide

Approvals

EN 50014, EN 50018, EEX de IIB T3

Weight

Total (excl. cable)	77 - 80 kg
---------------------	------------

Options

Polyurethane-lined wear parts	POLY-LIFE®
Impeller (MT, HT)	Stainless steel
Starters	
Various cable sizes	
Zinc anodes	
Tandem connection	

Accessories

Adapters, hose connections and other mechanical accessories. Electrical accessories such as pump controller, control panels, starters, monitoring relays, cables.

Rating

3~	
Rated output	9.7 kW
Speed of rotation	3400 rpm



www.flygt.com
www.xyleminc.com